



PDHonline Course A124 (4 PDH)

An Introduction to Roofing Systems

Instructor: J. Paul Guyer, P.E., R.A., Fellow ASCE, Fellow AEI

2020

PDH Online | PDH Center

5272 Meadow Estates Drive
Fairfax, VA 22030-6658
Phone: 703-988-0088
www.PDHonline.com

An Approved Continuing Education Provider

CONTENTS

- 1. STARTING POINTS FOR ROOF SYSTEM SELECTION**
- 2. SELECTION CONSIDERATIONS FOR STEEP ROOFING SYSTEMS**
- 3. SELECTION CONSIDERATIONS FOR LOW-SLOPE (MEMBRANE) ROOFING**
- 4. RE-ROOFING AND RE-COVERING**
- 5. ENVIRONMENTAL ISSUES**
- 6. DETAILED INFORMATION**
- 7. USING PRINCIPAL DESIGN CONSIDERATIONS TO REDUCE THE NUMBER OF POSSIBLE ROOF SYSTEMS**
- 8. CONSIDERATIONS WHEN SPECIFYING LOW-SLOPE (HYDROSTATIC) MEMBRANE ROOFING**
- 9. PRINCIPAL CONSIDERATIONS WHEN SPECIFYING STEEP-SLOPE (WATERSHEDDING) ROOFING**
- 10. ADDITIONAL CRITERIA AND DISCUSSION**

An Introduction to Roofing Systems

J. Paul Guyer, P.E., R.A., Fellow ASCE, Fellow AEI

1. STARTING POINTS FOR ROOF SYSTEM SELECTION. This Chapter is intended to introduce the major considerations in selecting a roofing system. Figure 1 depicts the various alternative roofing systems and how they relate. When commencing the selection process there are two different starting points.

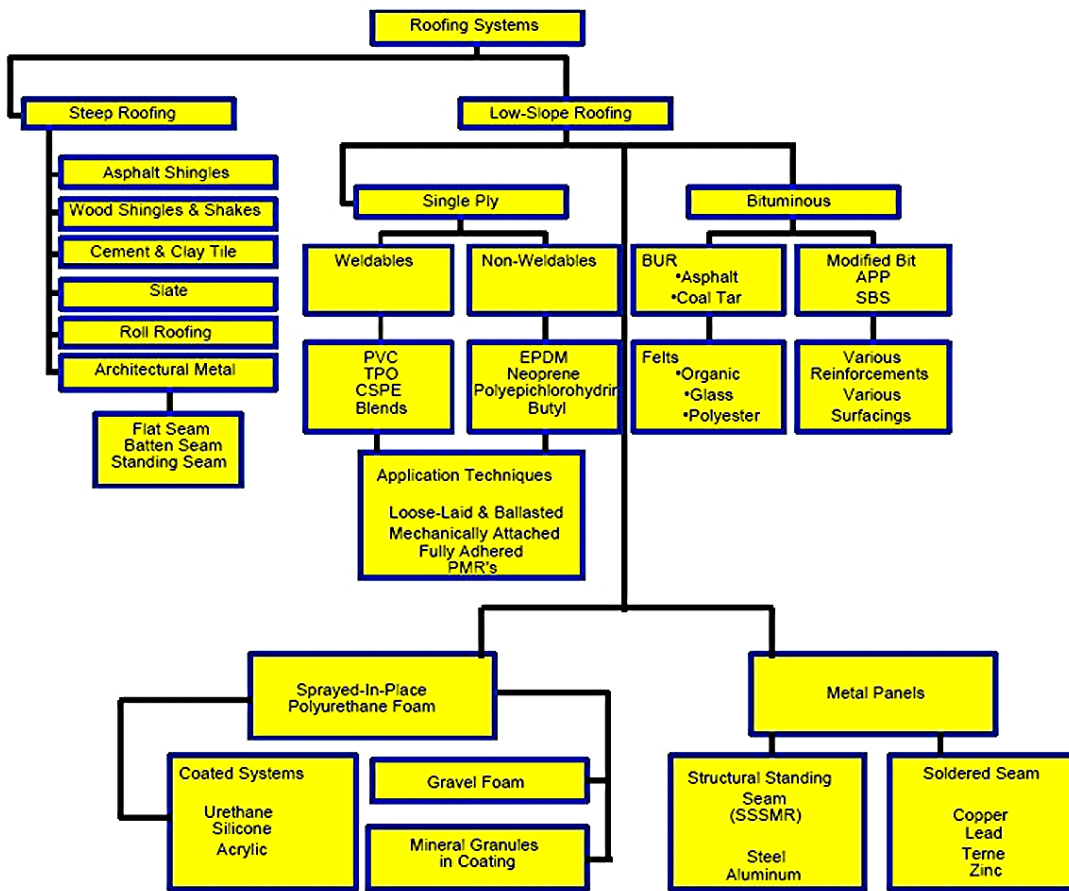

Material and Roofing System Options

Figure 1

1.1 New vs. Reroofing. The roof may be part of a new building design; or, it may involve the reroofing of an existing structure (replacement or re-cover). Today, approximately 75% of roofing activity is reroofing.

1.2 Steep-Slope vs. Low-Slope. In new construction the designer is very likely to have a preconceived notion as to whether a highly visible *sloped-roof* is wanted, or whether a less visible *low-slope* roof design is acceptable. Positive drainage is a very important design criterion. When reroofing, it may be feasible to improve drainage by using tapered insulation or sloped deck fills.

2. SELECTION CONSIDERATIONS FOR STEEP ROOFING SYSTEMS. Table 1 evaluates common steep roofing systems based upon some use criteria.

2.1 Aesthetics. Steep roof systems make a strong visible statement about a building. The texture, shadow-line, and color are major factors in selection.

2.2 Minimum Slope Requirements. Steep roofs function by shedding water rather than by being waterproof (Figure 2). Minimum slopes as shown in Table 13, are required in order to insure proper drainage.

2.3 Categories of Steep Roofing. Major categories of steep roofing include asphalt shingles, wood shingles and shakes, tile, slate, architectural metal, asphalt roll roofing, and fabricated units of metal or plastic intended to look like the others. Only asphalt roll roofing and asphalt or wood shingles may be re-covered.

2.4 Snowshedding and Ventilation. Sloped roofs are effective snowshedders. In addition, the attic space that accompanies steep roofing makes it easy to ventilate the roofing system.

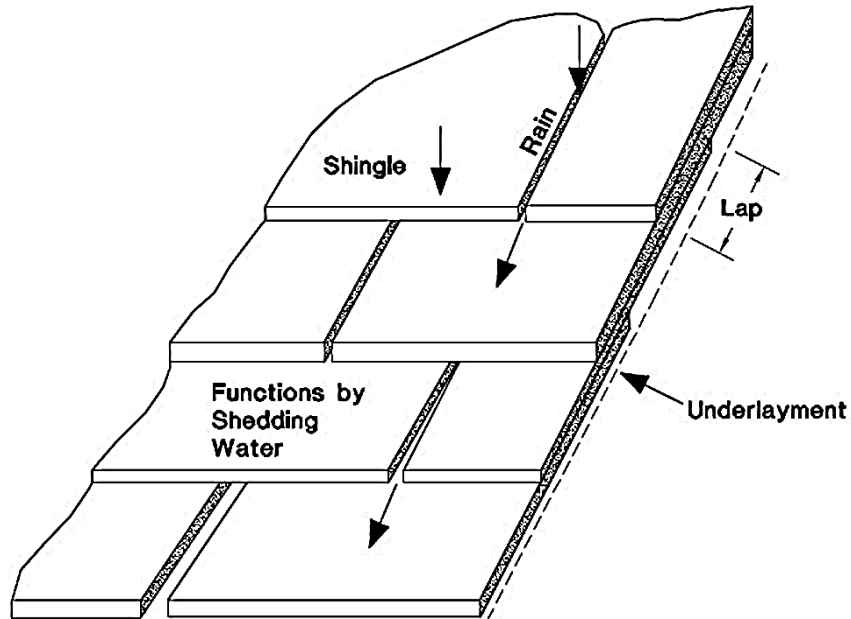

Steep Roofing (hydrokinetic)

Figure 2

**Lap Area Must Be Welded, Glued,
Taped, Etc., to Resist Water
Penetration**

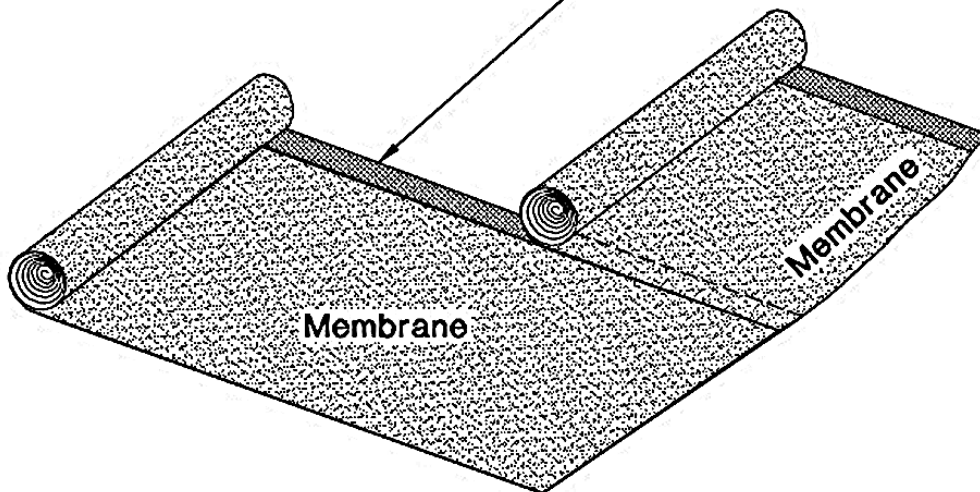

Low-Slope (hydrostatic)

Figure 3

2.5 Maintenance Requirements. Sloped roofs in general, require less maintenance than flat roofing systems.

2.6 Steep Roof Conversions. When considering reroofing a flat roof, it may be possible to convert the low-slope roofing system to a steeply sloped roof. This may improve the appearance of the building while resolving drainage problems as well. Steep roof conversions are a viable option for relatively narrow buildings.

	Asphalt Shingles			Asphalt Roll Roofing	Clay Tile	Concrete Tile
	Strip/Seal Down Interlocking	Laminated				
Severe Cold	Fair	Fair	Good	Fair	Poor	Poor
High Temp & Humidity	(e)	(e)	(e)	Fair	Fair/Good	Fair/Good
Severe Hail	Fair	Fair	Fair	Fair	Poor	Fair
Severe Wind	Fair	Fair	Good	Fair	(a)	(a)
Can Be Re-covered	Good	No	Good	Good	No	No
Appearance	Fair	Good	Fair	Fair	Good	Good

	Slate	Arch. Metal	Crafted Metal	Wood Shakes	Wood Shingles	Metal Look-Alike
Severe Cold	Fair	(c)	(d)	Poor	Poor	(c)
High Temp & Humidity	Fair/Good	Fair/Good	Fair/Good	(f)	(f)	Fair/Good
Severe Hail	Fair	Fair	(g)	Thickness	Poor	(g)
Severe Wind	Good	(b)	(b)	Thickness	Fair	(g)
Can Be Re-covered	No	No	No	No	Maybe	No
Appearance	Good	Good	Good	Good	Fair	Good

- (a) Requires nose clips, extra fastening
- (b) Depends upon gauge, clips design, closures
- (c) Requires sealed underlayments
- (d) Requires soldered joints, special detailing
- (e) Algae resistance is available
- (f) Treated wood needed
- (g) Heavier gauge better

Steep Slope Selection Based Upon Use Criteria

Table 1

3. SELECTION CONSIDERATIONS FOR LOW-SLOPE (MEMBRANE) ROOFING.

Membrane roofing is typically used on commercial buildings where the minimum slopes required by steep roofing render them impractical for larger buildings. Low-slope membrane systems are completely sealed at laps and flashings (Figure 3) and can temporarily resist standing water conditions. Choices for membrane roofing include multi-ply bituminous built-up (BUR), polymer-modified bituminous (MB), elastomeric

single-ply systems (e.g., EPDM), thermoplastic single-ply systems (e.g., PVC or TPO), sprayed-in-place polyurethane foam (SPF), and some metal (hydrostatic/low-slope/SSSMR) systems. Designers frequently select low-slope roofs when the roof is expected to accommodate rooftop equipment. With the exception of foam and metal, all low-slope systems can be incorporated into Protected Membrane Roof (PMR) designs.

4. REROOFING AND RE-COVERING.

4.1 Reroofing. The term *replacement* is used when the existing roofing system is to be either partially or totally removed and a new system installed. The designer should consider any existing problems and whether drainage and thermal performance needs to be improved. Existing surfaces such as walls and curbs may be contaminated with bitumen, which might affect compatibility with some reroofing options. Additional concerns (as compared to new roofing) include whether the existing structure can handle a significantly heavier roof system and whether construction activities of the reroof system will affect the occupants of the building (i.e., fumes, falling debris, and noise).

4.2 Re-cover. The term *re-cover* is used when a new roofing system is to be superimposed directly over an existing system. In this case, underlying conditions are obscured making assessment of their condition more difficult. Additional concerns include how the re-cover system will be attached to the existing membrane or roof deck, and compatibility with the substrate. The potential for trapped water between the old and new membrane may suggest the use of venting base sheets and/or roof vents.

5. ENVIRONMENTAL ISSUES. A relatively new design criterion is whether the roof system under consideration meets *green* criteria, such as whether the system incorporates postconsumer waste or is itself recyclable at the end of its useful life. Roof system waste is bulky and puts a great strain on waste disposal sites. Energy efficiency is also important in terms of raw materials acquired, production of finished goods, and application of the roof system. Thermal performance in service and retention of thermal

value with age are equally important. A *sustainable* or *robust* roof is highly desirable as extension of the life of the roof contributes to overall conservation. High albedo (reflective) roofs may improve localized climate conditions. The felt used in asphalt organic shingles consists primarily of recycled wastepaper, wood chips, and sawdust. Asphalt itself is a by-product of petroleum refining. Wood fiber and perlite roof insulation contain waste paper. Glass fiber and asphalt organic shingles have been recycled into asphalt curbing and the like. Wood shingles and shakes can be recycled into garden mulch. Steel and aluminum contain recycled scrap and at the end of their life, metal panels can be recycled back into scrap. Tables 2 and 3 compare environmental considerations for steep and low-slope roofing systems.

	Used Recycled Material	Minimize Health Risk	Maint/Repair (e)	Recyclable Reusable	Typical Durability	Re-cover w/o Removal
Asphalt Shingles						
Strip/Seal-Down	Yes	Yes	Easy	No (b)	15	Yes
Laminated	Yes	Yes	Moderate	No (b)	20	No
Interlocking	Yes	Yes	Easy	No (b)	15	Yes
Asphalt Roll Rfg	Yes	Yes	Easy	No (b)	10	Yes
Clay Tile	No	Yes	Moderate	Reusable	50	No
Concrete Tile	No	Yes	Moderate	Reusable	50	No
Slate	No	Yes	Moderate	Reusable	50	No
Architectural Metal	Yes	Yes	Moderate	Yes	(d)	No
Crafted Metal (Soldered)	Yes	Yes (a)	Moderate	Yes	25	No
Wood Shakes	Renewable	Yes	Easy	(c)	15	No
Wood Shingles	Renewable	Yes	Easy	(c)	15	Yes
Metal Look-Alikes	Yes	Yes	Moderate	Yes	(d)	No

(a) Lead-free solder.

(b) Economics not favorable at this time.

(c) Shred into mulch or incinerate.

(d) Finish may be warranted for 20 yrs.

(e) Ease of replacing damaged units.

Preserving the Environment – Steep Roofing

Table 2

	Use Recycled Material	Reuse Production Scrap	Minimize Health Risk	Maintainable/Sustainable	Recyclable at End of Life
Built-Up Roofing		Dry Felt			
Smooth	Yes		Good	Easy	No (d)
Capsheet	Yes		Good	Fair	No (d)
Aggregate	Yes		Except Tar	Difficult	No (d)
Modified Bitumens					
Unsurfaced	No		Good	Easy	No (d)
Capsheet	No		Good	Fair	No (d)
EPDM		Non-vulcanized			
Adhered	No		Good	Easy	No (e)
Mechanically Fastened	No		Good	Easy	No (c) (e)
Ballast	No		Good	Fair	No (c) (e)
PVC Plasticized		Recycle Trim			
Mechanically Fastened	Maybe		Good	Easy	Maybe
Fully Adhered	Maybe		Good	Easy	Maybe
Weldable Unplasticized		Unreinforced			
Mechanically Fastened	No		Good	Easy	Maybe (c) (e)
Fully Adhered	No		Good	Easy	Maybe
Ballasted	No		Good	Fair	Maybe (c) (f)
SPF	No	No	Once set	Easy	No
Hydrostatic Metal	Yes	Yes	Yes	Fair	Yes

- (a) Ballast could be reusable if cleaned and screened. Currently not done.
- (b) Polystyrene insulation in unadhered applications could be cleaned and reused.
- (c) Lightgard® pavers could be reused.
- (d) BUR scrap, asphalt, felt and aggregate could be recycled into curbs or into low grade paving if economics were more favorable.
- (e) EPDM could be reprocessed to extract oil, carbon, if economics were more favorable.
- (f) Aggregate could be washed and screened to remove fines.

Preserving the Environment – Low-Slope Roofing

Table 3

6. DETAILED INFORMATION. Once a tentative roofing system selection has been made using information provided by this discussion.

7. USING PRINCIPAL DESIGN CONSIDERATIONS TO REDUCE THE NUMBER OF POSSIBLE ROOF SYSTEMS.

7.1 Principal Design Considerations. Tables 4 and 5 list some of the principal design considerations in roof system selection. An explanation of the headings follows the tables. These tables are not all-inclusive but contain many criteria that the designer can consider to reduce the myriad of choices. Systems that fail to meet the principal project

design criteria can be quickly disqualified from further consideration. For example, if an existing structure has reached its design load limit, then heavier roofs (such as ballasted single-ply roofs or concrete tiles) would have to be disqualified (or the structure would have to be strengthened at significant cost).

Steep Sloped Roofing Systems	Initial Cost	LCC Cost	Construction Difficulty	Inspec. & Repair Difficulty	Life Years
Asphalt Shingles	L	L	L	L	15+
Wood Shingles	M	M	L	M	15
Wood Shakes	M	M	L	M	15
Slate	H	M	M	M	50
Concrete Tile	H	M	M	M	50
Clay Tile	H	L	L	M	50
Architectural Metal	H	L	L	M	20
Crafted Metal (Soldered)	H	M	H	M	50

Steep Sloped Roofing Systems	Suitable For Cold	Suitable For Hot	Wind Hail	Traffic Resist.	Resist Chem.
Asphalt Shingles	M	M (d)	M (c)	M	L
Wood Shingles	L	M (e)	L	L	L
Wood Shakes	L	M (e)	M	L	L
Slate	M	H	M	L	H
Concrete Tile	L	H (b)	M	L	M
Clay Tile	M	M (b)	H	L	M
Architectural Metal	M	H (a)	H	M	L
Crafted Metal (Soldered)	M	H	M	M	H (f)

- L = Low, M = Medium, H = High
- (a) Use heat-resistant underlayments.
- (b) Requires nose clips and ties for high winds.
- (c) Use extra nails and may require field application of tab cement or use of interlocking shingles.
- (d) Use fungus resistant granules.
- (e) Use rot-resistant (treated).
- (f) Depends upon metal selected.

Principal Design Considerations—Steep Roofing

Table 4

Low-Slope Roofing Systems	Initial Cost	LCC Cost	Constuction Difficulty	Insp. & Repair Difficulty	Life Years
BUR					
Smooth	L	M	L	L	15
Cap Sheet	L	M	L	L	15
Aggregate	M	L	L	M	20
MB	L	M	L	M	15
Single-Ply					
Mechanically	M	M	M	L	15
Adhered	M	M	M	L	15
Ballasted	L	L	L	M	15
PMR/Ballast	H	L	L	H	20+
SSSMR	H	M	M	M	20
SPF	L	M	L	L	20 (a)

Low-Slope Roofing Systems	Suitable For Cold	SuitableF or Hot	Wind Hail	Ponding	Traffic Resist	Resist Chem.
BUR						
Smooth	M	L	L	L	L	L
Capsheet	L	H	L	L	L	L
Aggregate	H	H	H	H	M	L (b)
MB	M	M	M	M	M	L
Single-Ply						
Mechanically	M	H	M	M	L	M
Adhered	M	H	M	M	L	M
Ballasted	M	M	H	M	L	M
PMR/Ballast	H	H	H	L	H	L
SSSMR	M	H	M	L	L	(c)
SPF	M	H	M	M	L	(d)

- L = Low, M = Medium, H = High
- (a) Requires periodic recoating.
- (b) Coal Tar resists petrochemicals.
- (c) Zinc/aluminum vulnerable to acids, alkali, salts. Sealants vulnerable to solvents, oils.
- (d) Depends upon coating selected.

Principal Design Considerations—Low-Slope Roofing

Table 5

7.2 Discussion of Headers in Tables 4 and 5.

7.2.1 Initial Cost. This may include materials, labor, and special set-up for construction.

Initial cost may determine if the roof, as designed, is affordable. Perhaps a somewhat less expensive system should be considered if it does not incur significantly increased maintenance costs or have a shortened life.

7.2.2 Life Cycle Cost. LCC considers durability but also presumes that routine maintenance will be performed to achieve the projected life. Consider whether the building is temporary or permanent. It would be hard to justify an expensive copper or slate roof on a building scheduled for demolition in the near future. Also consider the mission of the building. There are levels of quality in many systems. For example, while 45 mil EPDM is the standard, for little extra cost 90 mil material with greater puncture resistance, or conversion to a PMR system, could be specified for a building with a critical mission.

7.2.3 Construction Difficulty. Some systems require more clearance to accommodate application methods and equipment. Large prefabricated roof sheets (i.e., 50 ft. by 200 ft.) may be fine on a large roof with few penetrations, but are impractical on a roof area that is broken up by many curbs and equipment supports. On multiple penetration surfaces, relatively narrow sheets (e.g., BUR, MB, thermoplastic single-ply) or sprayed-in-place polyurethane foam should be considered. Penetrations through standing seam metal roofing need to accommodate the expected thermal movement of the metal panels. Thermal movement is cumulative, increasing with distance from the point where the panels are restrained (typically the eaves). Penetrations in SSSMR panels must pass through the flat portion of the panel, not through the standing seam. Penetrations wider than a single panel require a diverter to carry water around the obstruction. Water must flow parallel to the raised seams, never over them.

7.2.4 Periodic Maintenance—(The need for periodic maintenance and difficulty of

inspection or maintenance.) Some roof systems require periodic recoating for weather protection. Aggregate surfaced roofs are more difficult to inspect and patch than smooth surfaced roofs.

7.2.5 Life Expectancy. A mean life is listed but the actual life is affected by drainage, maintenance, and extreme use or abuse.

7.2.6 Suitability in Severe Cold. Effects of freeze-thaw, hail, ice scrubbing, and traffic while cold (i.e., snow removal) is considered. Some materials embrittle dramatically at low temperatures (i.e., have a relatively high glass transition temperature); others may embrittle as they weather and lose plasticizer or are degraded by UV or thermal load. **H** indicates highly suitable; **L** indicates less suitable.

7.2.7 Suitability in Extremely Hot or Humid Conditions. Effects of thermal expansion and algae growth are considered. **H** indicates more suitable, **L** indicates less suitable.

7.2.8 Wind Resistance. Roofs are vulnerable to wind scour and blow-off. While arbitrary ratings are provided here, the resistance is affected by building height, terrain, parapet height and measures taken to upgrade perimeter and corner attachment. **H** indicates highly wind resistant (when properly designed). For membrane roofing, impermeable roof decks such as cast-in-place concrete are best. Air retarders are needed with loose laid and mechanically fastened single-ply systems as they may otherwise balloon from interior air leakage. Perimeter wood blocking must be well anchored to prevent peeling of the membrane or loss of fascia metal. Avoid the use of small aggregate (e.g., pea gravel) near tarmacs and on skyscrapers due to the damage it can cause if blown off the roof by high wind. Asphalt shingles may require manual application of tab adhesive. Interlocking asphalt shingles provide excellent wind resistance. Metal panel systems are wind resistant only when all components including clips, fasteners, and secondary structural members are installed as wind-tested. SPF

has outstanding resistance to wind and to wind-blown missiles. SPF roofs performed well in hurricane Andrew, especially when they were spray-applied directly to concrete roof decks.

7.2.9 Resistance to Ponding Water. Membrane roof systems rely upon sealed seams to resist hydrostatic pressure. Water absorption may result in root or algae growth or cause rot. **H** infers highly resistant to these conditions.

7.2.10 Traffic Wear Resistance. Roofs that have a lot of rooftop equipment will have foot traffic that can cause punctures or abrasion. Most roof systems are available with traffic protective overlayers, such as walkways. **H** indicates highly resistant to abuse assuming protective courses have been used.

7.2.11 Resistance to Chemicals (resistance to oils, fats, grease, metal ions). Some roof surfaces are vulnerable to exhausted fumes or liquids. Thermoplastic polyolefins (TPO's) and Hypalon® (CSPE) may be better than bituminous materials in resistance to oils, greases, and solvents. Copper-containing runoff water from condensate coils or flashings will corrode zinc and zinc-aluminum SSSMR roofing. **H** indicates better than average resistance to attack.

7.3 Weight Factor. Consider the total number of roofs already installed, the weight of the proposed roof system possible, and construction loads. The unit weight of membrane systems vary dramatically, ranging from less than 0.5 psf for a 2 in. thickness of SPF, to more than 20 psf for ballasted single-ply systems. Typical roof system weights and construction loads are shown in Table 6.

7.4 Compliance with Fire & Wind Requirements. Roofing systems are rated as entire systems, including the roof deck, method of attachment to the deck (e.g., fasteners, hot bitumen, cold adhesives), vapor retarder (if used), thermal insulation, roof membrane, and surfacing. Typical External Fire Ratings (ASTM E-108, Class A, B or C) are shown in Tables 7 and 8. Combustible decks (wood/plywood/OSB) require selected

combinations of underlayments, insulation, roofing, and surfacing to resist burning brands and intermittent flame as described in ASTM E108.

7.5 Roof Decking. Principle roof decks for membrane roofing include steel, cast-in-place concrete, precast concrete, wood, plywood, OSB, and structural wood fiber. Variations of cast-in-place concrete include lightweight structural concrete (typically 1680 kg/m³)(105 psf) and lightweight insulating concrete(480 kg/m³)(30 psf). In new design, the roof deck is generally selected based upon construction considerations and materials. Steel is by far the most popular, followed by concrete and plywood/OSB. Table 9 lists some criteria for deck selection for new construction. Table 9 lists methods of attachment to the roof deck. Attachment options include full adhesion, mechanical fastening, and loose-laid/ballasted roofing. Steel decking requires a bridging course typically mechanically fastened roof insulation. For steep roofing, plywood and OSB roof decks are most common. They generally utilize flexible batts as underdeck roof insulation although architectural metal and cathedral ceiling constructions may use rigid insulation above the deck.

7.6 Suitability of the Membrane for the Substrate. Table 10 lists some possible combinations.

	Wt kg/m ²	Wt lb./sq.ft
Steep Roofing		
Asphalt Shingles	10 to 20	2 to 4
Wood Shingles	15 to 20	3 to 4
Wood Shakes	15 to 20	3 to 4
Concrete Tile	38	9
Clay Tile	38	9
Slate	38	9
Architectural Metal	2 to 13	0.5 to 3
Built-Up Roofing		
Smooth	10	2
Aggregate	24 to 34	5 to 7
BUR with Capsheet	7 to 10	1.5 to 2
Modified Bitumens		
Smooth or Capsheet	7 to 10	1.5 to 2
Single-Ply		
Mechanically fastened (or fully adhered)	5	1
Ballasted	50 to 100	10 to 20
PMR (including ballast)	24 to 100	5 to 20
Standing Seam Metal	5 to 10	1 to 2
Sprayed in Place Polyurethane Foam	2 to 5	0.5 to 1
Weights of Typical Roofing Equipment		
Ballast buggy with hopper extension	725	1600
Pallet of modified bitumen (16 rolls)	680	1450
Tear-off machine	180	400
Deballasting machine	385	850
Ballast hopper—loaded	1630	3600

Typical Weights of Material and Equipment

Table 6

	ASTM E108 Class A, B, or C	Underlayments
Asphalt Shingles		
Asphalt-Organic	C	No. 15/30 Felt
Asphalt-Glass	A	No. 15/30 Felt
Asphalt Roll Roofing	B/C	Base Sheet
Clay Tile	A	No. 30
Concrete Tile	A	No. 30
Slate	A	No. 30
Architectural Metal	Underlayment-?	(a)
Crafted Metal	Underlayment-?	(a)
Wood Shakes	C	(a)
Wood Shingles	C	(a)
Metal Look-Alikes	Underlayment-?	(a)

- (a) May require gypsum board or special fire resistant underlayments for combustible decks.

Fire Ratings and Required Underlayments for Steep-Sloped Roof Systems

Table 7

	ASTM E108 Class A, B, C Combustible Decks (c)	ASTM E108 Class A, B, C Noncombustible (e)	Metal Deck Construction
Built-Up Roofing			
Smooth	B	A	Isoboard/Perlite/Glass Fiber
Capsheet	B	A	Isoboard/Perlite/Glass Fiber
Aggregate	A	A	Isoboard/Perlite/Glass Fiber
Modified Bitumens			
Unsurfaced	B-FR. (d)	A-FR.	Isoboard/Perlite/Glass Fiber
Capsheet	B-FR.	A-FR.	Isoboard/Perlite/Glass Fiber
EPDM			
Adhered	C-FR.	A-FR.	Isoboard (b)
Mechanically Fastened	C-FR.	A-FR.	Isoboard/Perlite/Glass Fiber
Ballast	A	A	Isoboard/Perlite/Glass Fiber
PVC Plasticized			
Mechanically Fastened	B	A	Isoboard/Perlite/Glass Fiber
Fully Adhered	B	A	Isoboard (b)
Weldable Unplasticized			
Mechanically Fastened	C-FR.	A-FR.	Isoboard (b)
Fully Adhered	C-FR.	A-FR.	Isoboard (b)
Ballast	A	A	Isoboard (b)
SPF	A	A	Some Listed Systems
Hydrostatic Metal	(a)	A	Not Required

- (a) Depends on underlayment/(gypsum board?)
- (b) Perlite/glass fiber may not be acceptable to single-ply systems because of asphalt content or dusty/solvent-degradable surface.
- (c) On combustible decks, mass of surfacing or underlayment is important to prevent ignition of the deck.
- (d) FR. means Fire Retarded Sheet required.
- (e) Non-Combustible decks include steel, concrete and masonry.

Fire Ratings and Required Underlayments for Low-Slope Roof Systems

Table 8

Deck Type	Economy	Long Spans Available	Resist. Heavy Roof Traffic	Seismic Resist.	Internal Fire Resist.	External Fire Resist.	Wind Resist.
Insulated Steel	E	No	F	E	F	E	G
Cast-In-Place Concrete	P	No	E	F	E	E	E
Precast Concrete	P	Yes	E	G	E	E	G
Plywood or OSB	G	No	P	E	P	P	F
Structural Wood Fiber	P	No	P	F	P	F	P
Lightweight Insulating Concrete	F	No	G	P	G	E	G

E= Excellent, G = Good, F = Fair, P = Poor

Suitability of the Roof Deck for Various Conditions

Table 9

Membrane:	Deck Type					
	Insulated Steel/ Other	Uninsulated Concrete	Uninsulated Wood/OSB	Existing Bituminous System	Cementitious Wood Fiber	Lightwt. Insulating Concrete
Fully Adhered						
Built-Up Roofing	Hot Asphalt	Prime/Hot	Nail Base	Re-cover Board	Nail Base	Nail Vent Base
Modified Bituminous	Hot Asphalt	Prime/Hot	Nail Base	Re-cover Board	Nail Base	Nail Vent Base
Single-Ply	Adhesive	Fleece-back/Hot	Tape Joints	Re-cover Board	N/A	(a)
SPF	N/A	Yes	Seal Joints	Yes	N/A	N/A
Mechanically Attached						
Built-Up Roofing	Mop to Insulation	N/A	N/A	Re-cover Board	Nail Base	Nail Vent Base
Modified Bituminous	Mop to Insulation	N/A	N/A	Re-cover Board	Nail Base	Nail Vent Base
Single-Ply	Special Fasteners	Predrill Deck	Special Fasteners	Separator Needed	Special Fasteners	Special Fasteners
Loose-Laid & Ballasted						
Single-Ply	Ballast	Cushion	Check Structure	Separator	Check Structure	N/A

(a) Lightweight structural concrete 1880 kg/m³ (105 pcf) may be acceptable.

Membrane/Substrate Compatibility/Attachment Methods

Table 10

7.7 Thermal Insulation. Rigid thermal insulations used under membrane roofing include wood fiber, perlite fiber, glass fiber, foamed glass, polystyrene (extruded or expanded), and polyisocyanurate (isoboard). Non-structural thermal insulations include glass fiber and mineral wool batts, blown loose insulations such as cellulose fiber, glass fiber, mineral fiber, and expanded vermiculite. Table 11 indicates suitability of rigid roof insulations for membrane roofing based upon intended method of use.

	Direct Attachment to Steel Decks	Mechanical Attachment	Solvent Adhesive	High Thermal Value/Unit Thickness	Fire Resistant	Asphalt Compatible	Use in PMR
Wood Fiber	(a)	Yes	Yes	No	No	Yes	No
Perlite Fiber	Yes	Yes	(b)	No	Yes	Yes	No
Glass Fiber	Yes	(f)	Yes	No	Yes	Yes	No
Polystyrene MEPS	(c)	(d)	No	Yes	No	No	No
Polystyrene XEPS	(c)	(d)	No	Yes	No	No	Yes
Polyisocyanurate	Yes	Yes	Yes	Yes	Yes	(e)	No
Foam Glass Board	Yes	Yes	Yes	No	Yes	Yes	No
Mineral Wool Fiber	Yes	(f)	No	No	Yes	Yes	No

- (a) Wood fiber is available with <4% asphalt to meet under-deck fire requirements for steel decks.
- (b) Asphaltic adhesives are permitted to attach membranes to perlite boards, but not single-ply adhesives.
- (c) Some polystyrene applications have passed fire testing when used in conjunction with single-ply systems only. It is not universally agreed that this is an acceptable application.
- (d) Mechanical fasteners compress polystyrene insulation, resulting in loss of restraining force. Overlay with rigid board such as perlite.
- (e) Overlay with non-foam layer for hot BUR or MB application.
- (f) Special stress plates needed to recess heads of screws.

Suitability of Roof Insulation for Method of Use

Table 11

7.7.1 Thickness of Insulation. If thick layers of insulation are needed to meet a high therm resistance, thicker wood nailers and deeper fascia metal will be required. Foam plastics such as polyisocyanurate and polystyrene have the highest R values per unit thickness.

7.7.2 Clearance of Metal Panels. In standing seam metal roof systems, the permissible thickness of blanket insulation may be limited by the clearance provided by the supporting clip design.

7.7.3 Insulated Attic. Blanket insulation used in steep roofing systems is frequently placed on the floor of the attic where R-values of 30 (RSI = 5.4) or more may be possible (Figure 13).

7.7.4 Ceiling Insulation. Dropped ceilings are sometimes insulated by placing batts directly above the ceiling panels. This practice is not recommended as subsequent access to underdeck equipment or phone wires is blocked. When the insulation is displaced to gain access it is rarely put back in place correctly, if at all.

7.8 Suitability for Extreme Climates. Protected membrane systems (PMRs) are very well suited to extremely cold climates and have been successfully used in all climates. For extreme conditions of snow and ice, a cold (ventilated) roof should be considered. For most steep roofing this is achieved by allowing a flow of outdoor air between the insulation and the roofing system. This air cools the roof in summer, dries out any moisture that condenses in the roof, and greatly reduces the formation of icicles and ice dams along eaves. For regions prone to severe hail, ballasted EPDM roofs are very good and PMRs are excellent. Tiles, shingles, bare BUR, and metal systems are easily damaged by hail. In regions of semitropical climate (high temperatures and humidity), asphalt shingles should be treated to be fungus resistant and wood shakes/shingles should be pressure treated for rot resistance.

7.9 Installation in Cold or Wet Weather. Most membrane systems are difficult to install in subfreezing weather. If frequent precipitation during construction is a problem, factory fabricated single-ply systems with field welded seams may have advantages over systems where field application of adhesives or hot bitumen is needed. Torch applied modified bitumens are one of the few systems that can be applied, albeit slowly, in wet windy conditions.

7.10 Warranties. The NRCA *Commercial Low-Slope Roofing Materials Guide* contains a comprehensive side-by-side comparison of commercial roof warranties. The roofing

industry offers two general types of warranties: Materials Only and Materials & Workmanship. Carefully read exclusions and limits. Note: The longest warranties are not necessarily the best, nor does the length of the warranty directly relate to roof durability. In many cases, manufacturers may restrict their warranties.

7.11 Maintenance Considerations. Sloped roofs require less routine maintenance and may be preferred when the facilities management is incapable of providing routine inspections and minor repairs. Modified bituminous and BUR systems may be superior in abuse resistance to thin single-ply systems. Various protection boards/walkways can be used around equipment where traffic is anticipated. Protected membrane roof systems (PMR's) are abuse resistant but more difficult to inspect and repair.

7.12 Roof Access, Fumes and Property Protection When Reroofing.

7.12.1 Fumes. In reroofing situations fumes from kettles and solvents may be objectionable. Hot coal tar pitch is especially objectionable; hot asphalt is also noticeable but less noxious. Cold applied systems with taped or welded seams and metal roof systems generate few odors. It may be necessary to coordinate air-conditioning shutdown to avoid taking fumes into the occupied building.

7.12.2 Ease of Construction Access. If the area around the construction site is congested it may make heating and hoisting of roofing materials difficult.

7.12.3 Specifying Construction Procedures. Site access, material storage area, layout area, building and landscape protection should be identified on drawings.

7.12.4 Safety and Disturbance to Occupants. The presence of occupants, vehicles, and pedestrians may be of concern. Reroofing is noisy. Dust and overspray may affect those nearby.

7.13 Installation. Roofing requires skilled installers. Qualified contractors and inspectors are more likely to be available if the system is customarily used in the region. It should be determined whether there are several manufacturer-approved installers capable of bidding the work.

7.14 Owner Preferences. Verify that the contemplated system is acceptable to the owner, occupants, and maintenance personnel.

8. CONSIDERATIONS WHEN SPECIFYING LOW-SLOPE (HYDROSTATIC)

MEMBRANE ROOFING. With the exception of SSSMR, membrane roofing requires a suitable roof deck. Most constructions will also use thermal insulation. Vapor retarders are sometimes required to protect the roofing system from attack by interior moisture.

8.1 Built-up Roofing (BUR). BUR Consists of multiple reinforcements such as asphalt treated glass or organic felt laminated together with hot-applied bitumen (asphalt or coal tar pitch) or cold adhesives (Figure 4). Surfacing include aggregate, coatings, capsheets, and sprayed roofing granules. A typical system includes thermal insulation and may include a vapor retarder.

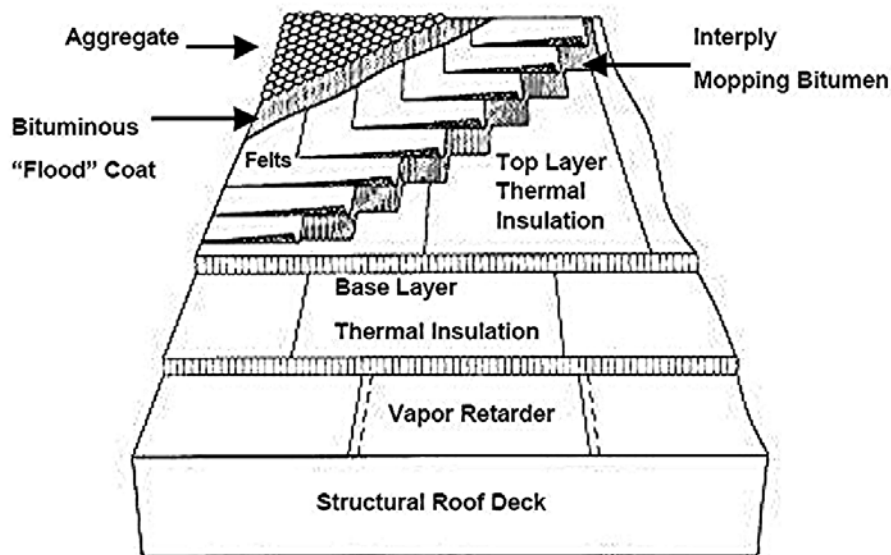

Typical BUR System

Figure 4

b. Polymer Modified Bitumen. MB consists of reinforcing sheets factory-coated with polymer modified bitumen. They may be laminated in the field using hot bitumen, heat fusion, or by cold adhesives (Figure 5). Surfacing include capsheets with mineral granules, metal foil, and field applied coatings.

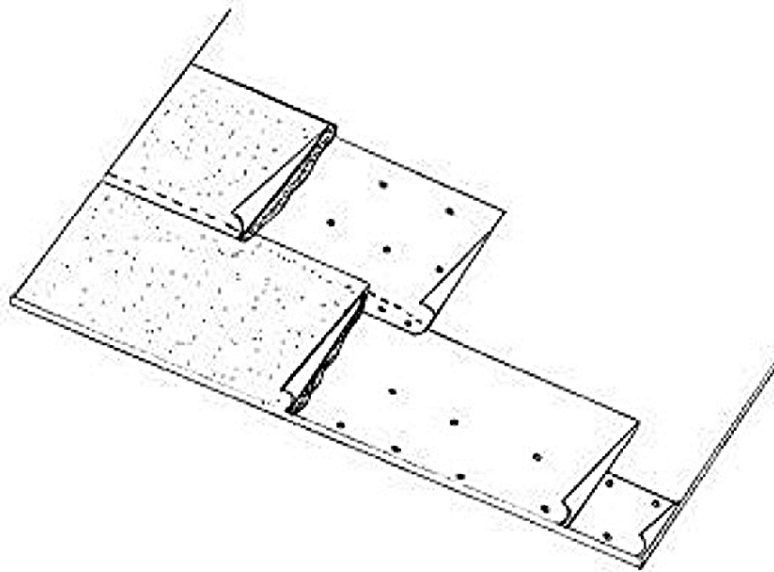

Polymer-Modified Cap Sheet Adhered to Mechanically Fastened Base Sheet

Figure 5

c. Elastomeric (Single-Ply) Membranes. Elastomeric membranes consist of a factory produced sheet generally of EPDM rubber with seams field-sealed with adhesive or tape (Figure 6). Sheets are unsurfaced unless ballast is used. Elastomers are vulcanized (thermoset), and usually non-reinforced except when used in mechanically fastened systems. A fleece-backed sheet is also available for fully adhered systems when it is desired to use hot bitumen as an adhesive (e.g., for re-covering an asphalt-contaminated deck or old BUR).

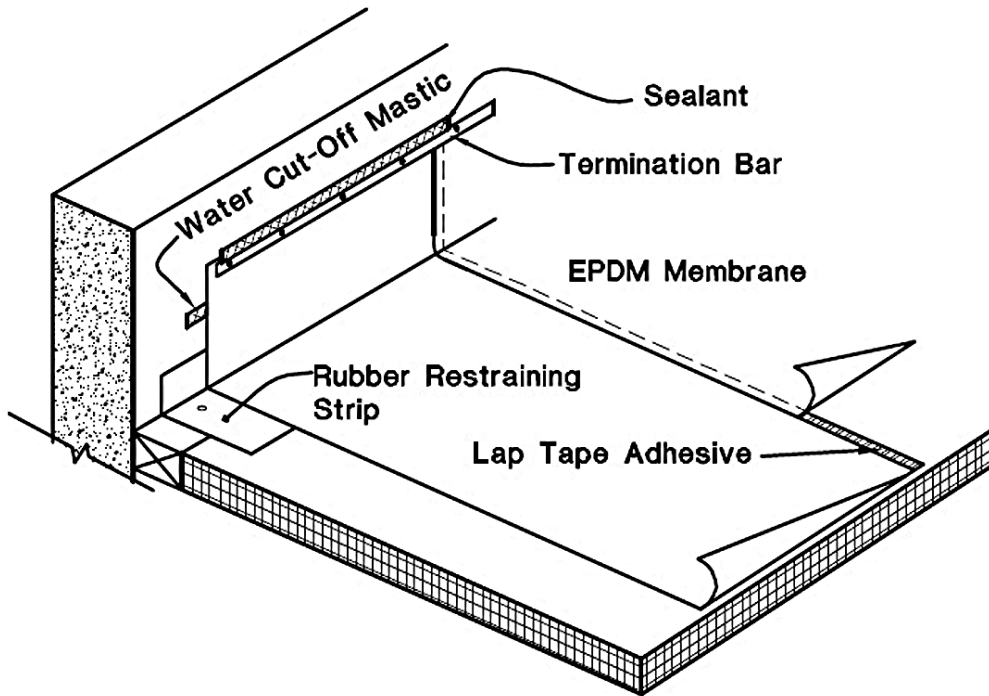

EPDM Roof System

Figure 6

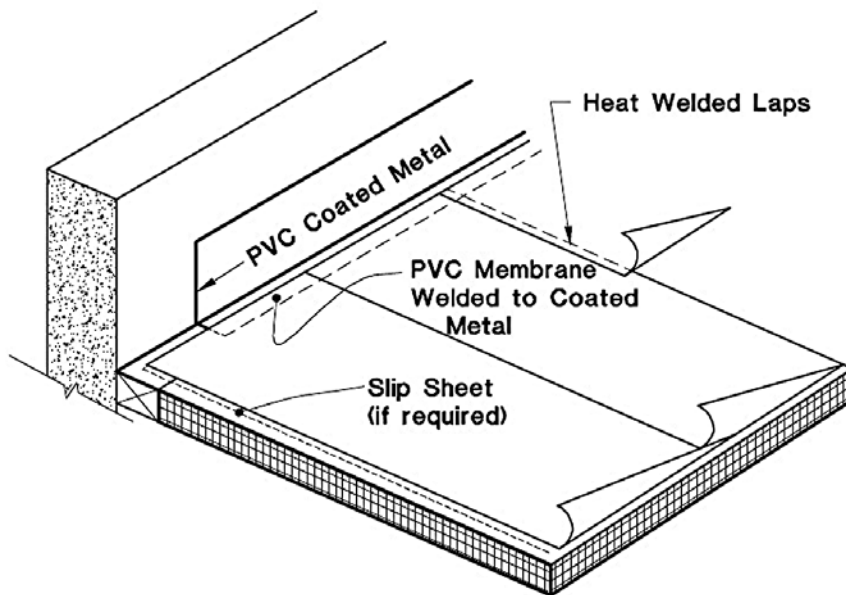

PVC Roof System

Figure 7

8.4 Weldable Thermoplastic Membranes. These membranes consist of a sheet of reinforced thermoplastic material such as PVC or TPO. Sheets are unsurfaced or ballasted. Seams are generally heat fused although solvent welding and adhesive bonding are also possible (Figure 7).

8.5 Structural Standing Seam Metal Roofing. SSSMR consists of metal panels with raised seams more than 1-1/2 in. high (Figure 8). Sealants are utilized at side seams and endlaps to provide waterproofing. Most are considered hydrostatic, resisting standing snow and occasional ponding. Caution: ridges and valleys of a SSSMR may not be as watertight as the seams.

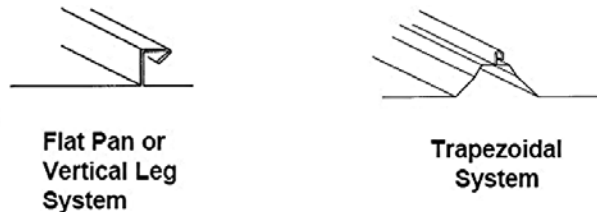

Notes:

1. SSSMR System with roofing panels greater than 300 mm (12 in.) should have standing seams rolled during installation.
2. Non-structural, non-hydrostatic standing seam metal roof systems may look similar.

Structural Standing Seam Metal Roofing

Figure 8

8.6 Sprayed-in-Place Polyurethane Foam. SPF is a thermoset rigid foam, field-formed by the reaction of liquid components (in the presence of a foaming agent) sprayed onto the substrate. SPF is protected by liquid-applied elastomeric coatings or an application of loose gravel (on slopes < 4%).

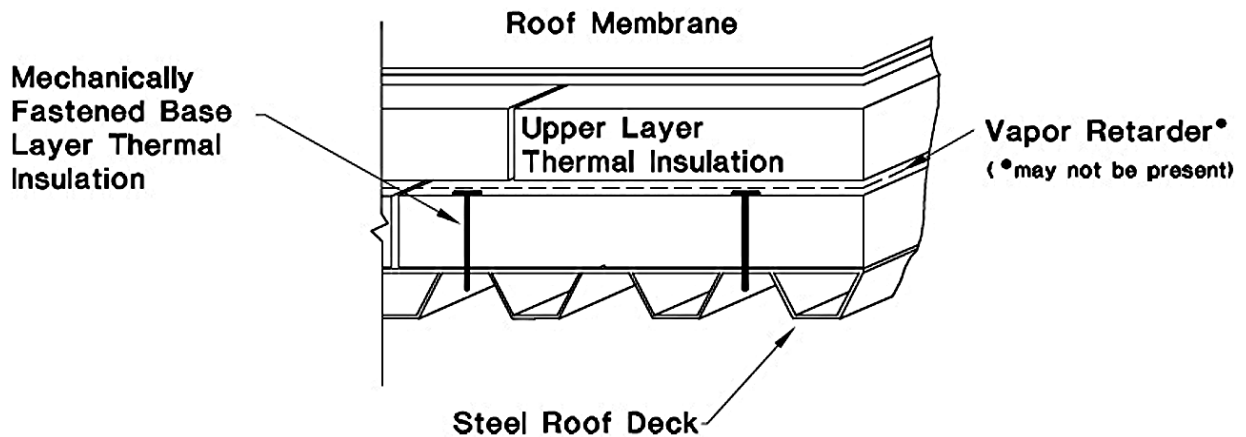

Components of Membrane Roofing System

Figure 9

8.7 Components of Membrane Roofing Systems (Figure 9).

8.7.1 The deck supports roofing loads and is selected to conform to fire resistant design classifications. Not all systems require a deck (e.g., structural standing seam metal roofing).

8.7.2 A vapor retarder protects the insulation against moisture vapor attack from the warm, high vapor pressure side of the roof assembly. Not all buildings require a vapor retarder.

8.7.3 An air barrier prevents air movement (infiltration or exfiltration) through the roofing system.

8.7.4 Thermal insulation provides thermal resistance and prevents condensation on components beneath the insulation. It also furnishes support and a smooth, continuous substrate for the membrane.

8.7.5 The membrane is intended to keep water out of the components below (as well as out of the building). The membrane system affects fire resistance.

8.7.6 Individual roofing components may be held in place by adhesives, fasteners, ballast, or a combination of these methods.

8.7.7 Perimeter flashings are waterproof vertical terminations of the membrane (perimeter flashing) (Figure 10).

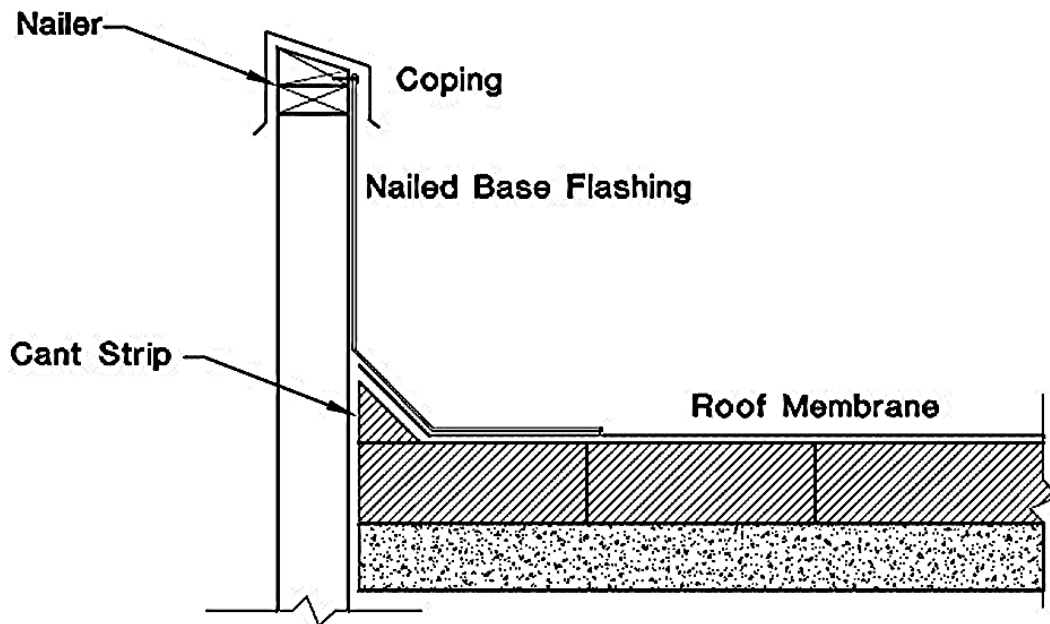

Wall Base and Cap Flashing

Figure 10

8.7.8 Roof edging and fascia are usually low profile roof edge terminations and side trim.

8.7.9 Roof penetrations include drains, vents, curbs, equipment supports, and the like.

8.7.10 Surfacing materials screen UV light, improve fire ratings, and may improve water and/or hail resistance.

8.8 Attachment for Low-Slope Roof Systems.

8.8.1 Full Anchorage. For relatively inelastic roof membranes such as BUR and MB, solid adhesion helps restrain the roof membrane and uniformly distribute thermal stresses. When insulation is used, it is fastened or adhered to the deck. The membrane is fully adhered to the thermal insulation using hot asphalt or cold adhesive.

Polyurethane foam is sprayed directly to the substrate, especially in re-cover of existing BUR thereby being fully adhered as well.

8.8.2 Partial Attachment. In partially attached systems the membrane is mechanically anchored through the insulation into the deck, or in a few cases, partially adhered with strips or spots of adhesive. This is common with flexible single-ply roof membranes. Fasteners are typically placed in the seams area where by can be covered by the overlapping sheet.

8.8.3 Loose-Laid Attachment. For loose-laid systems the membrane is unattached to the substrate and is held in place by ballast. Restraint is required only at perimeters and curbs. Loose-laid roofs are used with elastomeric (EPDM) and some thermoplastic (e.g., TPO) systems. These are very inexpensive roof systems *if* the structure can handle the ballast weight.

Caution:

In positive pressure buildings air barriers should be used with loose laid and partially attached membranes to avoid billowing and peeling.

8.9 Labor.

8.9.1 Highly Intensive: BUR, MB

8.9.2 Moderately Intensive: SSSMR—The system is very unforgiving of installation defects.

8.9.3 Medium Intensity: Fully adhered and mechanically fastened single-ply.

8.9.4 Low Intensity: Spray Foam requires the smallest crew (but is the most machine intensive and weather sensitive).

8.10 Slope.

	% Min.	In./ft. Min.	% Max.	In./ft. Max.
Ballasted Membranes	2	1/4	16.7	2
Gravel Surfaced BUR	1	1/8	25	3
Cap Sheets, Narrow Lap Widths	2	1/4	50	6
MB smooth or Cap Sheet	2	1/4	50	6

Some Typical Slope Limitations for Low-Slope Roof Systems

Table 2-12

9. PRINCIPAL CONSIDERATIONS WHEN SPECIFYING STEEP-SLOPE

(WATERSHEDDING) ROOFING. This category covers systems that range from asphalt shingles, wood shingles and shakes, clay and concrete tile, slate, and metal look-a-likes. Also included are architectural metal panels with a variety of seams (Figure 11). Slopes are generally 25% (3:12) or greater. Most must be continuously supported on a solid deck (e.g., plywood or oriented strand board [OSB]). However, some varieties (e.g., clay and concrete tiles) may be supported on spaced horizontal batten boards. Underlayments such as roofing felt, self-adhering MB or plastic film are usually required over the entire roof to provide a secondary line of defense against driving rain and blowing snow. In cold regions, a completely sealed MB underlayment is needed along

eaves, in valleys, and at dormers, skylights, chimneys and such to resist leaks from water ponded behind ice dams.

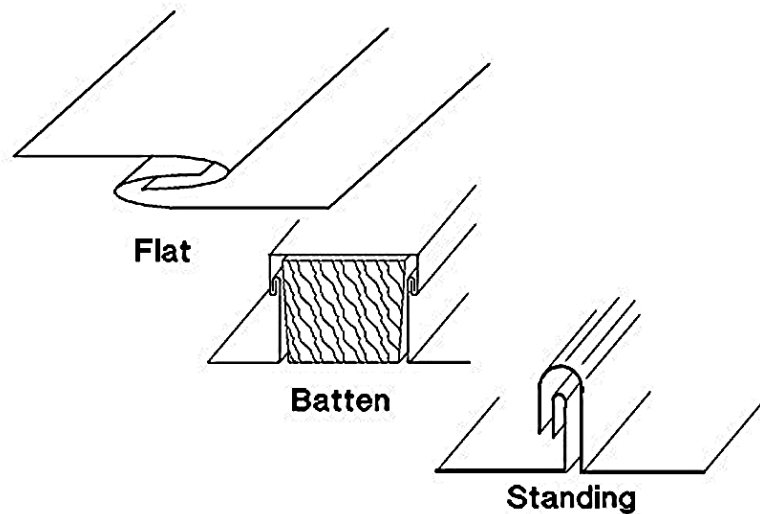

Architectural Metal Seams

Figure 11

9.1 Aesthetics. By their very nature steep roofing is highly visible. Appearance may be of primary concern to the designer. Regional preferences exist. For example, red tile roofing is very common and highly desirable in the Southwest, while light gray concrete tile is preferred in Florida. Wood shakes give a textured natural look preferred in the Pacific Northwest.

9.2 Labor Intensity and Labor Skill.

9.2.1 High Intensity. Heavy brittle units of clay, tile or slate.

9.2.2 Medium Intensity. Architectural metal, wood shakes.

9.2.3 Low Intensity. Shingles.

9.3 Watershedding. Steep roofs rely on gravity to cause water to flow away from headlaps. Recommended minimum slopes are shown in Table 13. Lower slopes are sometime permissible by increasing overlap or enhancing the waterproofness of the underlayment.

	In./ft.	%
Asphalt Shingles	4	33
Wood Shakes	4	33
Slate	4	33
Tile	4	33
Wood Shingles	3	25
Asphalt Shingles with Sealed Underlayment	2	17
Roll Roofing	1	8
Architectural Metal	4	33
Some Architectural Metal with Sealed Underlayment	3	25
Structural Metal without Waterproof Joints	3	25
High Seams and Underlayments	2	17
Structural Metal with Waterproof Joints in Some Climates	1/2	4

Minimum Slopes for Typical Steep Roofing Systems

Table 13

9.3.1 Valleys and Eaves. Valleys must be well constructed. The slope of a valley will be less than that of the intersecting planes that form it. Exterior drainage over the roof edge or to a gutter is typical but may be troublesome in cold regions since ice dams may form there.

9.3.2 Underlayments. Sealed underlayments of self-adhering modified bitumen are typically used along the eaves to at least 24" beyond the interior wall line (Figure 12a) and as valley lining. Occasionally the entire roof deck is covered with such a membrane. Note that this can lead to problems if indoor moisture is not isolated from the roof by well made vapor and air barriers. Underlayments are used in steep roofing as a secondary defense against water penetration (Figure 12b). These include No. 15 felt,

No. 30 felt, and self-adhering MB sheets. For hydrokinetic and crafted metal, self-adhering MB sheets are essential as a secondary water barrier.

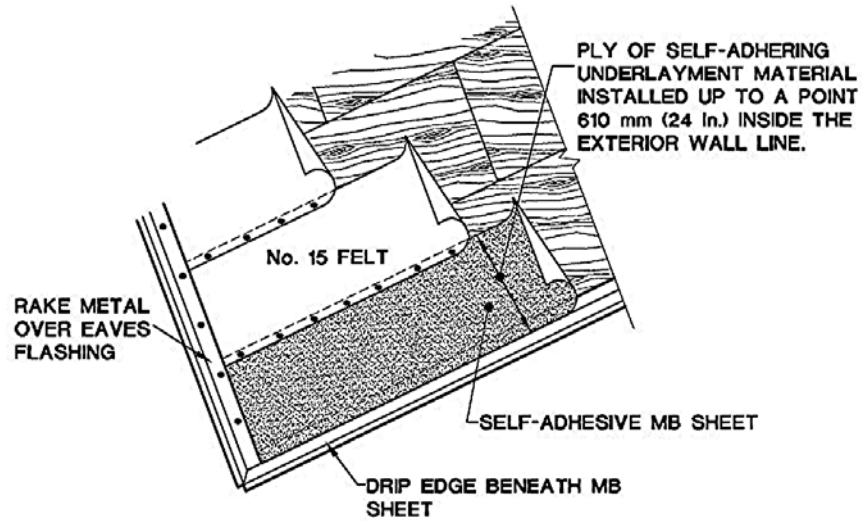

Self-Adhesive Eaves Flashing

(Underlayment is sealed from eave to 24" within wall line.)

Figure 12a

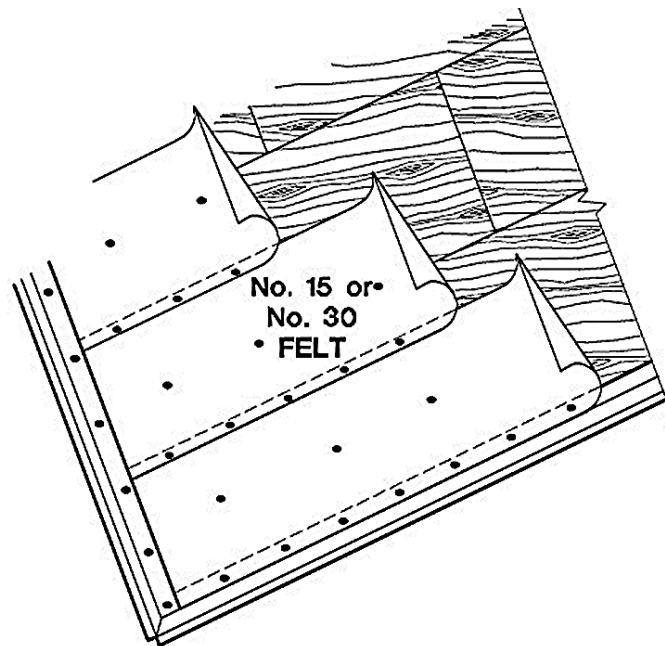

Underlayment for Steep Roofing

(Underlay felt is unsealed)

Figure 12b

9.3.3 Energy Efficiency. Steep roofs generally cover an attic space (figure 2-13) (with the exception of cathedral ceilings). The floor of an attic can be inexpensively insulated with nonstructural insulations such as fiberglass batts, mineral wool, expanded vermiculite, or treated cellulose. Where the thickness of the insulation is not limited by clearance problems, very high thermal resistances (e.g., $R_{si} > 5.56$, $R > 30$) can be achieved. If a vapor retarder is required for a cold arctic climate the retarder needs to be placed on the interior (warm side) of the insulation. The attic space above this insulation should be ventilated to remove moisture and to keep the attic relatively cold; this minimizes ice damming at eaves.

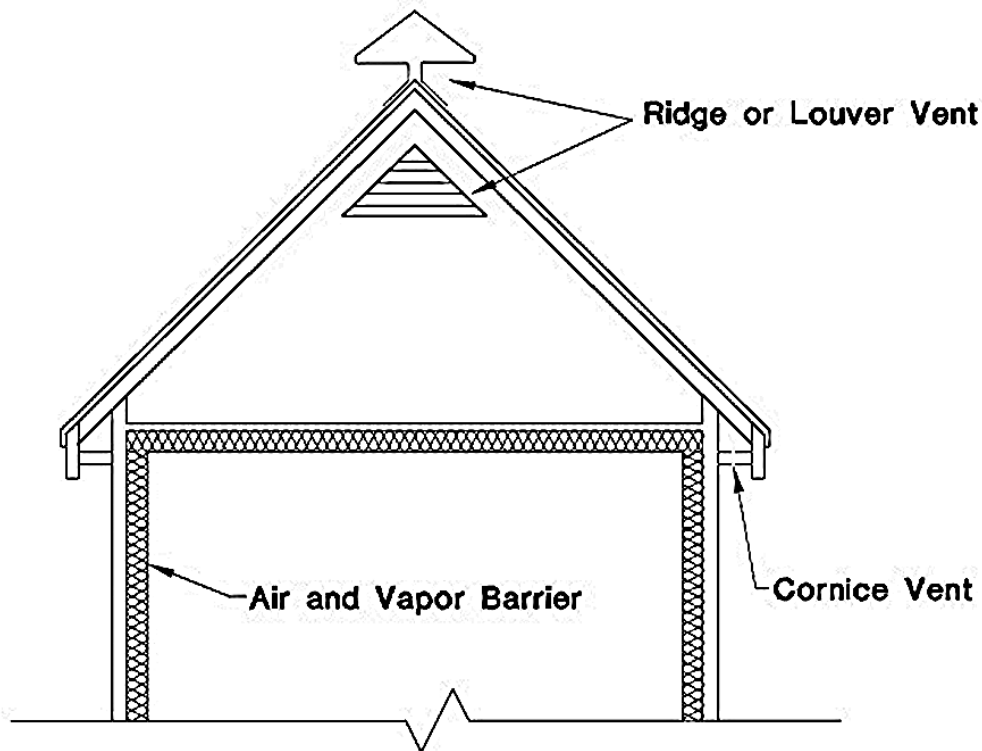

Vented Attic Space

Figure 13

9.3.4 Durability. Mean durability of common steep roofing has been estimated in one survey as:

	Years
Natural Slate	60
Clay Tile	47
Asbestos Cement Shingles	31
Metal Panels	28
Organic Fiber/Cement Shingles	26
Better Quality Asphalt Organic Shingles	18
Better Quality Asphalt Glass Fiber Shingles	18
Cheap Asphalt Shingles (don't use)	Perhaps only 10

Mean Durability of Common Steep Roofing

Table 14

10. ADDITIONAL CRITERIA AND DISCUSSION.

10.1 Wind. Maximum wind speeds associated with locality and storm type determine needed resistance. ANSI/ASCE 7-95 and EI01S010 provide design information.

10.1.1 Adhered Systems. Air impermeable roof decks such as poured concrete, with adhered or mechanically fastened insulation and fully adhered membranes, are highly wind resistant. Tests conducted by the Factory Mutual System have determined that BUR systems installed this way have resisted 8.6 kilopascals (180 psf).

10.1.2 Metal Panel Systems. Metal panels are generally rated by the Underwriters 580 procedure, with UL 90 ratings considered excellent. However, because some SSSMR panel systems with UL 90 ratings have failed in service, structural standing seam metal roof systems must pass the ASTM E1592 test method.

10.1.3 Ballasted Systems. Ballasted single-ply systems rely on heavier and larger ballast in more wind prone exposures. SPRI has developed wind guidelines in their ANSI-SPRI RP-4 document based upon ANSI/ASCE 7-95 guidelines. Higher parapets

have a beneficial effect on ballasted systems. Above certain building heights, SPRI recommends against the use of ballast.

10.1.4 Mechanically Fastened Systems. Mechanically fastened single-ply systems use narrower starter sheets and increased fastener density in high wind areas. Examples of layout can be found in Factory Mutual Loss Prevention Data Sheet 1-29.

10.1.5 Foam Systems. Sprayed-in-Place Polyurethane Foam (SPF) systems have proven very wind resistant and are effective in protecting the structure against wind hurled missiles.

10.1.6 Problems with Small Roof Aggregate. Roofs adjacent to airport tarmac activities should avoid aggregate surfacing as loose aggregate may be blown off the roof and sucked into engines. Loose stone ballast which is much larger, is used successfully at many airports.

10.1.7 Wind Rated Roofs. Underwriters Laboratories lists wind rated systems in their Roofing Materials and Systems Directory as Class 30, 60 or 90. Factory Mutual Research Corporation lists wind rated systems in their *Approval Guide* with ratings ranging from 60 to 210 psf.

10.1.8 Steep Roofing. For most steep roofing systems, additional fastening is required for high wind areas (e.g., six fasteners per asphalt shingle instead of four, addition of nose clips for tiles, etc.).

10.2 Ice and Hail. The formation of ice can cause the roof membrane to split. Ice can also affect roofing performance by scrubbing the membrane and eroding the surface. This can be especially detrimental to materials with a relatively high glass transition temperature (T_g). Bituminous materials have a T_g of approximately 32°F. Modified bituminous materials with an SBS modifier can have a T_g as low as minus -30°F.

EPDM membranes report a T_g less than -40°F. The T_g of thermoplastics may increase with age (i.e., loss of plasticizer in PVC). Ponding promotes ice damage; drainage avoids it.

10.2.1 Impact Damage. Falling ice, such as from overhead towers, causes impact damage. Ballasted EPDM provides some protection. Protected membrane roofs in which both polystyrene insulation and ballast are placed over the finished roof membrane provide excellent impact resistance.

10.2.2 Perimeter Icing. Ice formation at eaves, scuppers, and gutters is a major design concern. For low-slope roofing selection of internal drainage where building heat keeps the drain lines unfrozen is recommended.

10.2.3 Minimizing Icing Problems. For metal and steep roofing heating cables are sometimes necessary but not especially reliable. In cold regions use of a cold roof in which the roof is ventilated to prevent formation of icicles and ice dams is preferred. Self-adhering waterproof membranes are needed to avoid leaks from ice damming (Figure 10).

10.2.4 Hail Damage. Weather maps are available that generally divide the U.S. into regions that require resistance to severe hail (2 in. dia.), moderate hail (1-1/2 in. dia.), and areas of low hail probability. Hail resistance is affected by the compressive strength of the substrate, thickness of the membrane, tensile strength, and age/brittleness of the material.

10.3 Snow. Snow removal operations in which shovels or snow blowers are used can cause severe damage especially to cold, brittle membranes. Smooth single-ply membranes and metal roofing are extremely slippery when wet or when a thin ice film covers melt water. Roof walkways consisting of compatible materials are essential when it is necessary to walk on wet or frozen roofs.

10.3.1 Metal Roofs. TI 809-52 recommends that SSSMRs should have a minimum slope of 8.3% in cold regions.

10.3.2 Snow Loads. Snow load information is available in ANSI/ASCE 7-95, TI 809-01, and TI 809-52.

10.4 Slope. Drainage is essential on all roofing systems. For hydrokinetic roofing the drainage must be positive and rapid. Shingles, tiles, and the like, generally have industry minimum recommended slopes of 33% to 42%. Sometimes a lower slope option is available if waterproof underlayments are used.

10.4.1 Metal Roofs. Minimum slopes for metal roofs vary from 4% to 33%, depending upon roof type.

10.4.2 Membrane Slope. Low-slope membranes should also comply with a minimum slope of 2% (1/4 in./ft.). Where ponding is unavoidable such as in spray ponds, a BUR with double poured aggregate and bitumen is sometimes used. Coal tar pitch membranes are used at slopes as low as dead level and to a maximum slope of 2% (1/4 in./ft.). drainage is also needed. However, small puddles are inevitable as SPF is never completely smooth. Small puddles should dry out within 24-48 hours after inclement weather. Additional elastomeric coating is recommended where ponding is anticipated.

10.4.3 Foam Slope. For Sprayed-in-Place Polyurethane Foam (SPF) systems positive drainage is also needed. However, small puddles are inevitable as SPF is never completely smooth. Small puddles should dry out within 24-48 hours after inclement weather. Additional elastomeric coating is recommended where ponding is anticipated.

10.4.4 Reroofing. In reroofing and re-covering applications, correcting the slope to 2% (1/4 in./ft.) is sometimes unfeasible because of low windows, flashings, etc. In these cases, tapered insulation at 1.5% (3/16 in./ft.) slope may be an acceptable compromise.

10.4.5 Steep Roof Conversion. Conversion of a poorly draining roof to a steep roofing system may be accomplished on a relatively narrow roof system building by installing new sloped joists.

10.5 Vapor, Humidity, Moisture and Condensation. Moisture can be carried through materials by diffusion or by the movement of air. Air barriers are needed to reduce air movement. They can be located anywhere within the building envelope. Vapor retarders, when needed, must be placed within the warm portion of the thermal insulation.

10.5.1 Self-Drying Systems. In cold weather, warm moist indoor air driven from within the building towards the colder exterior may accumulate during the winter then dry back out again during the summer months. Guidelines for the use of vapor retarders in roofs are presented in CRREL Misc. Paper 2489, *Vapor Retarders for Membrane Roofing Systems*. Figure 14a indicates suggested maximum allowable relative humidities where summer dry-out should be adequate. Figure 14b is used to adjust Figure 14a for temperatures other than 60°F.

10.5.2 Reverse Vapor Drive. For hot humid climates a reverse vapor drive may occur especially in cooler and freezer buildings. In this case the membrane and wall retarder sealed and continuous. Roof vents and breathing edge details must be avoided. For freezer buildings, consider separating the roof system from the freezer.

10.5.3 High Humidity Occupancies. For buildings with high interior relative humidity including bakeries, laundries, pools, kitchens, dining halls with serving lines and the like, vapor retarders are considered essential.

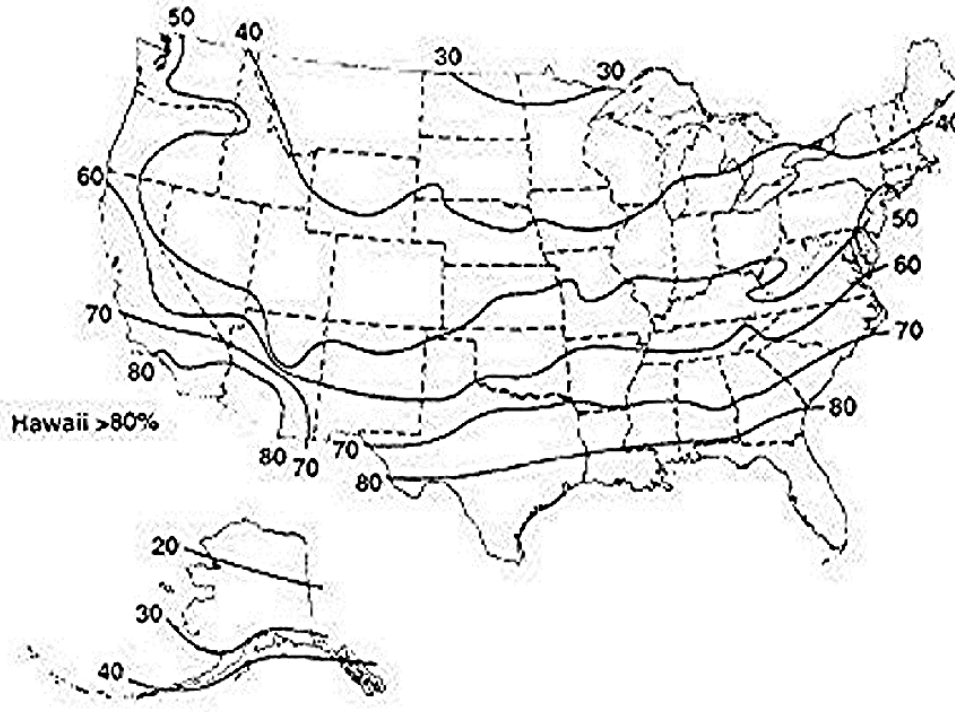

Interior Relative Humidities (%) with Interior Temperature of 68°F)

Figure 14a

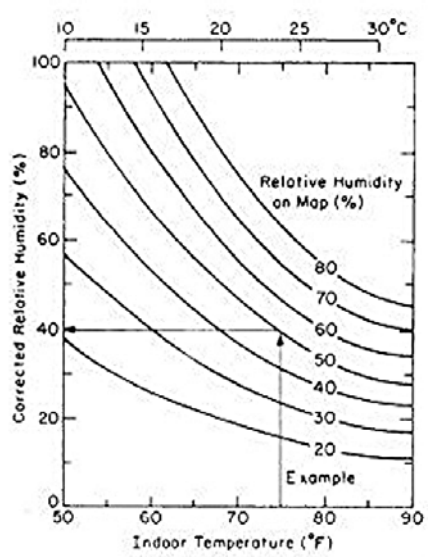

Notes:

1. If designed interior RH is expected to exceed the percentages shown in 2-14a, summer self-drying will be inadequate and vapor retarders should be used.
2. Use 2-14b to correct maximum RH for interior temperatures that differ from 60°F.

Temperature Conversion When Temperatures Differ from 68° F

Figure 14b

Offices	30-50%
Hospitals	30-55%
Computer Rooms	40-50%
Department Stores	40-50%
Swimming Pools	50-60%
Textile Mills	50-85%

Typical Indoor Relative Humidity in Winter

Table 15

10.5.4 Bituminous Vapor Retarders. Bituminous retarders are installed over solid fire barrier substrates such as concrete, gypsum board, or a fire resistant insulation. Bituminous retarders have near zero perm ratings. For most membrane roofing systems vapor retarder permeance should be below 0.5 perms (28.6 ng/s•sq m•Pa). Perm ratings for various vapor retarder materials can be found in the *ASHRAE Handbook of Fundamentals* as well as in industry literature.

10.5.5 Non-bituminous Vapor Retarders. Non-bituminous single-ply systems may use plastic films as vapor retarders. These can be successful if the seams and penetrations are carefully sealed with tape. Puncturing the retarder, either accidentally or by installing mechanical fasteners lessens its resistance to moisture.

10.5.6 PMRs. Protected Membrane Roofing systems (PMR's) are very effective against vapor drive from within the building. The roof membrane itself serves as the vapor retarder as most, if not all, of the thermal insulation is located above it. Self-drying of the insulation (extruded polystyrene) to the atmosphere maintains the thermal resistance.

10.5.7 SPF Systems. SPF systems are commonly installed on re-cover installations where

the old bituminous membrane can be sealed to form a retarder. Dew point calculations are necessary to insure the dew point is within the upper SPF layer.

10.5.8 Steep Roofing. In steep roofing systems the retarder is usually a plastic film (poly), treated kraft paper or foil facing on batt insulation installed with the retarder facing the interior. When an attic or cathedral ceiling is present, ventilation of the space above the insulation is essential since retarders are rarely completely sealed and some moisture accumulation would otherwise occur. Most codes recommend at least 1:150 net free ventilation area (total at eave and ridge) when a retarder is not installed to 1:300 when a retarder is in place. In cathedral ceiling construction larger net free areas are needed since friction losses in the narrow airway reduce ventilation.

10.5.9 Metal Systems. In structural metal systems where draped batt insulation is used, it is difficult to completely seal the retarder facer even if tape is used. When high interior vapor conditions exist the use of a subdeck to support a retarder film may be necessary. Other roofing systems should also be considered as such systems are not good at resisting high internal relative humidities.

10.6 Considerations When Using Thermal Insulation. Thermal insulation is important in modern buildings both for energy conservation and human comfort and may impact roof membrane performance.

10.6.1 Thermal Resistance. Resistance to heat flow through the entire roof structure (characterized by the R factor) should be as high as is both practicable and cost effective. In general an R factor of > 20 ($R_{si} > 3.57$) is recommended. Note: $U = 1/R$ therefore, the U factor should be < 0.05 Btu/hr•ft² °F.

	Density (pcf)	R/Inch (Hr·°F/btu)	W·°C/m ²
Rigid Boards			
Rigid Polyisocyanurate Foam	2.0	6.2	1.1
Extruded Polystyrene Foam (XEPS)	2.2	5.0	0.88
Glass Fiber Boards	14	4.0	0.73
Expanded Polystyrene Foam (MEPS)	1	3.8	0.67
Foamed Glass	9	2.9	0.50
Expanded Perlite	10	2.8	0.49
Wood Fiber	18	2.8	0.49

SPF	2.7	6.2	1.1
Batts and Blankets			
Rock/Slag/Glass	1.5	3.5	0.53
R value varies with in-place density			
Loose Fill Insulations			
Cellulose (milled paper)	2.8	2.3	0.40
Expanded Perlite	5.6	4.1	0.72
Rock/Slag/Glass Fibers	1.5	0.6	0.10
Vermiculite, Exfoliated	7.6	7.0	1.23

Note: Thermal resistance ($R=1/C$ where $C = k/\text{thickness}$). The higher the thermal resistance, the more efficient the insulation. Resistance may decline with age due to diffusion of air into foam cells (aging of foam). Absorption of water can reduce the insulating ability of most insulations to a small fraction of their dry value.

Unit Resistances (i.e., Resistivity) of Common Roof Insulations

Table 16

10.6.2 Installation Locations. Thermal insulation may be installed in four locations.

10.6.2.1 Underdeck insulation (Figure 15).

- Wood frame structures with steep roofing often utilize batt insulation placed between the rafters. Vapor retarders of foil, kraft, or plastic film are located on the inside face of the insulation. With structural standing seam metal systems, batts are draped over the purlins. In attics, the insulation is usually positioned between ceiling joists.
- An advantage of underdeck insulation is that inexpensive nonstructural insulations such as batts may be used.

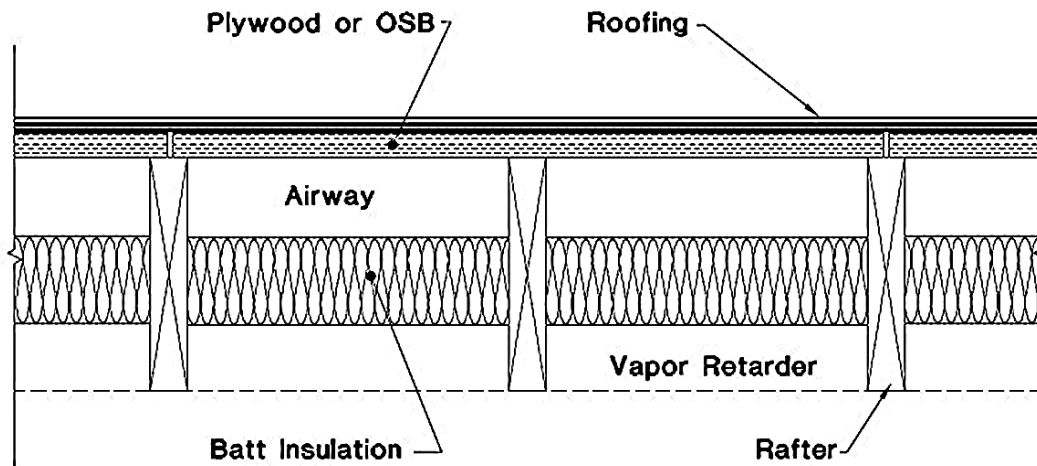

Under Deck Insulation

Figure 2-15

- A disadvantage is that the roof deck suffers greater thermal stress than when it is overlaid with insulation. Another disadvantage is that it is difficult to vapor seal such construction and make it resist air exfiltration and as a result moisture problems are prone to occur. Ventilation is usually required but ventilating low-slope framed roofs lacking tight air barriers is apt to increase moisture problems, not eliminate them.
- Common underdeck materials include compressible batts of glass fiber and mineral wool. Thermal spacers of rigid plastic foam are placed over the purlins of SSSMR systems to maintain the thermal resistance where the batts are compressed.

10.6.2.2 Self-insulating roof deck (Figure 16):

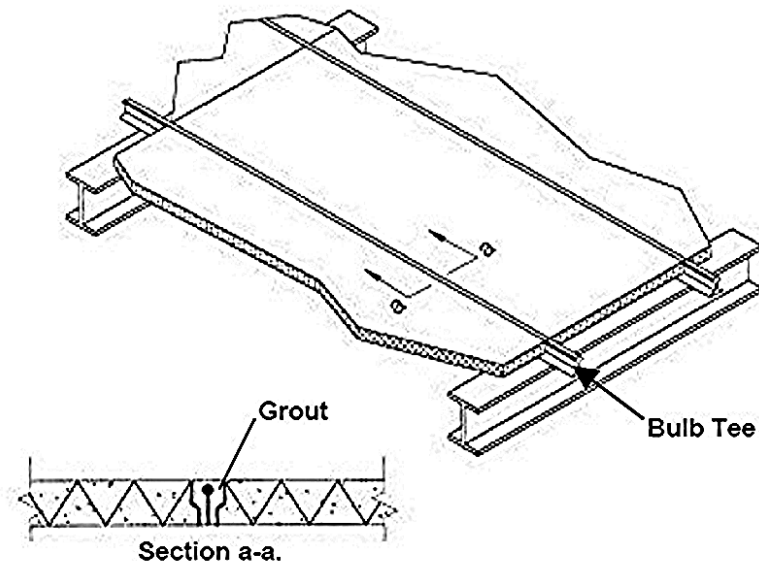

Self-Insulating Roof Deck

Figure 16

- Insulating decks such as structural wood fiber are less popular today because it is difficult to achieve high R values within the deck itself. In reroofing situations supplemental insulation would often be added on top of such a deck. In some new assemblies a composite of structural wood fiber topped with plastic foam is used. The underside of these self-insulating decks can be exposed to the interior and serves as an attractive acoustical ceiling.

10.6.2.3 Thermal insulation within the roofing sandwich (Figure 9).

- Insulation on top of the roof deck is the most common configuration for membrane roofing. For adhered membrane systems the thermal insulation restrains the membrane against wind loss or shrinkage and must have adequate structural strength. For mechanically anchored and ballasted systems compressive strength and stability are important. If hot asphalt or solvents are used in construction of the membrane, the insulation must resist degradation by these agents.

- Common materials for adhered systems include faced polyisocyanurate foam (ASTM C1289), perlite (ASTM C728), rigid glass fiber boards (ASTM C726), wood fiber (ASTM C208), and cellular glass (ASTM C552). Verify that the combination of membrane and roof insulation/facer are Fire and Wind Rated.
- For mechanically fastened and ballasted systems expanded and extruded polystyrene (ASTM C578) are added to the above list. (They could melt or dissolve if placed in contact with hot bitumen or solvent-based adhesives).
- Some decay of R value is observed with HCFC blown foams (urethanes and isoboard) due to diffusion of air and moisture into the cells of the foam. Manufacturers publish aged R values to reflect this decay. Always use aged R-values for these materials. Since diffusion starts at the surface of the foam, thicker foams are more thermally stable.
- Wood fiber boards should be manufactured to use as roof insulation (meeting ASTM C208), not sheathing boards, and should be limited to 4 ft. in length and width.
- When mechanical fasteners are used to secure thermal insulation, it is recommended that the nail-one, mop-one technique be used. This minimizes thermal bridging and avoids nail-popping of the membrane. When multiple layers of insulation are used, vertical joints should be offset to reduce heat losses. Straight-through joints can take away 10% of a roof's insulating ability.

(d) Protected membrane systems (Figure 17).

- In PMR systems only extruded polystyrene is suitable in the sometimes wet environment above the completed roof membrane. This insulation protects the membrane from thermal stress and abuse.

- Ballast and filter fabric is needed to hold the loose-laid insulation in place.

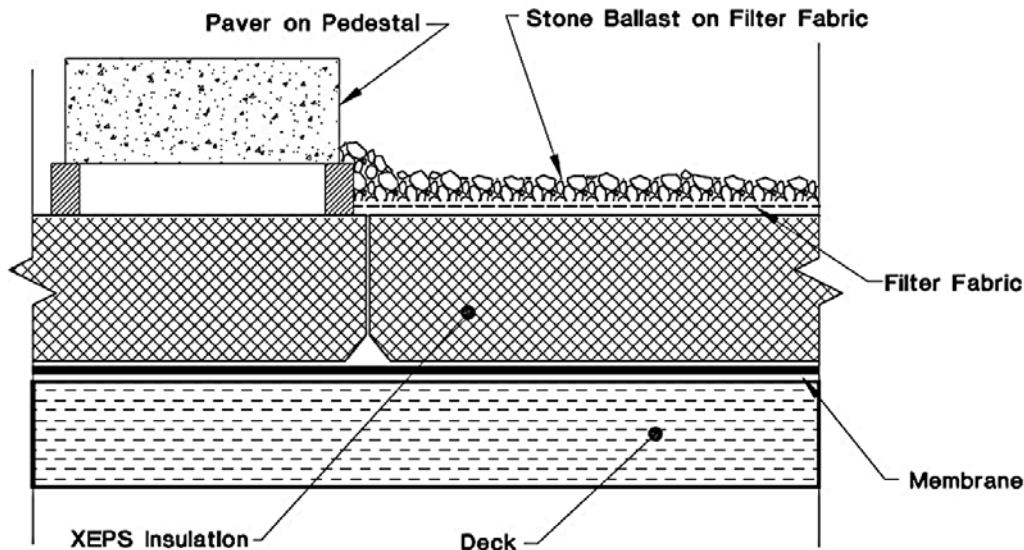

Note: Because the membrane is on the warm side of the insulation, it also serves as a vapor retarder.

Protected Roof Membrane System (PMR)

Figure 17

10.7 Energy and Solar Radiation. The ratio of roof area on a low-rise commercial building is high relative to wall area. Such roofs can provide a great opportunity for energy conservation. This can be accomplished by using well insulated, high thermal mass structures to reduce summer cooling loads, garden roofs, or high albedo roof coatings.

10.7.1 Heat Gain. For roofs in hot or temperate climates, light colored roof surfaces reduce heat gain. For membrane roof systems, light colored aggregate (gravel surfaced roofs) or mineral granules (capsheets [ASTM D249, D371, D3909] and MB capsheets [ASTM D6162, D6163, D6164, D6222, D6223]) will reduce heat maximum surface temperatures by up to 35°F over black membranes. Aluminum coatings (ASTM D2824) are approximately the same, while white coatings (ASTM D6083) have been observed to reduce temperatures by more than 45°F (provided that the roof stays clean). The use of pavers and heavy ballast reduce heat gain through thermal lag; that is, the high heat

capacity stores some of the gained heat delaying the startup of the building's air conditioning system. The ASHRAE *Handbook of Fundamentals* uses the term Equivalent Temperature Difference (ETD) in energy calculations. The smaller the ETD, the better the system is at reducing peak solar loads.

Construction	ETD (°C)	(°F)
Light (wood, metal deck)	33	60
Medium (gypsum, lightweight concrete, 100 mm (4 in.) concrete slab)	29	52
Heavy (150 mm [6 in.] + concrete slab)	25	45

Equivalent Temperature Difference

Table 2-17

reflective roof surfacing materials (e.g., white granules on shingles). Radiant barriers (reflective foils) placed in attics are also effective.

10.8 Fire Considerations.

10.8.1 Topside Fire Ratings. Because of its large surface area, roofing plays an important role in fire protection. Fire hazards can be defined as:

10.8.1.1 External, where the source is outside the building such as from wind blown flaming debris. Tests for external fire resistance are referred to in building codes as Class A, B and C.

- An external fire rating is established by constructing and testing roofing assemblies by methods described in ASTM procedure E108 (also known as UL790). In this method relative degrees of fire resistance are established.
 - Class A roof coverings are effective against severe fire exposures. Under such exposures roof coverings of this class are not readily flammable and do not carry or communicate fire; afford a fairly high degree of fire protection to the roof deck; do not slip from position; possess no flying brand hazard; and, do not require frequent repairs in order to maintain their fire-resistant properties.
 - Class B roof coverings are effective against moderate fire exposures. Under such exposures roof coverings of this class are not readily flammable and do not readily carry or communicate fire; afford a moderate degree of fire protection to the roof deck; do not slip from position; possess no flying brand hazard; but, may require infrequent repairs in order to maintain their fire-resistant properties.
 - Class C roof coverings are effective against light fire exposures. Under such exposures roof coverings of this class are not readily flammable and do not readily carry or communicate fire; afford some degree of fire protection to the roof deck; do not slip from position; possess no flying brand hazard; and, may require occasional repairs or renewals in order to maintain their fire-resistant properties.
- Class A does not mean Grade A! *Note: In this classification only fire performance is considered. A specifier should select the degree of fire resistance required but recognize that selecting a higher rating does not assure better waterproofing nor longer life. In fact, some compromise in durability may have been made to meet the higher fire rating.*

- ASTM E108 fire tests may be conducted on steep roofing, membrane roofing, SPF, and metal panels. Listings of systems that meet these requirements are found in the Underwriters Laboratories *Roofing Materials and Systems Directory*, the Factory Mutual
- *Approval Guide*, and reports/directories published by several other qualified testing agencies.
- Qualified listings:
 - If a roofing assembly fails to meet burn-through requirements of ASTM E108 it may still be listed for use with non-combustible decks such as steel, concrete, and gypsum.
 - Roofing assemblies are listed at the maximum incline to which the rating applies. As long as the structure under consideration is at a lower or equal incline to that listed it complies with the fire rating.
 - If a listing is intended for use as a roof superimposed over an existing roof, it should be listed in the UL *Roofing Materials and Systems Directory* under the category *Maintenance and Repair Systems*. In the FM *Approval Guide* it will be listed as a *Re-cover*.
 - In general, only the materials listed qualify and only when used in the manner described in the directories. Additional insulation, for example, might worsen the flame spread.

10.8.1.2 An internal (underdeck) fire is when the flame spread is underneath the roof deck. Listings are referred to by the Approval Rating, usually *Factory Mutual Class 1* or *Underwriters Laboratories Insulated Metal Deck or Non-metallic Decks Constructions*.

- **Background**—In 1953, a large insulated steel roof deck building suffered an unexpected, catastrophic fire loss due to an underdeck fire exposure. The roofing components above the deck contributed fuel to spread the fire. Tests conducted on full scale test buildings confirmed the hazard. In the late 1950's, laboratory tests were established and correlated to the full scale data. Factory Mutual uses a calorimeter to establish fire performance while Underwriters Laboratories uses a modified Steiner Tunnel test. Successful systems are listed by FM as Class 1 while Underwriters lists them as either Rated Metal Deck or Rated Non-Metallic Assemblies.
- **The underdeck ratings** do not assure zero risk. The ratings assume an acceptable risk assuming normal fire detection and fire control procedures are available. If an insulated steel deck system fails to comply with the requirements of FM Class 1, it is designated Class 2. Class 2 constructions may be converted to Class 1 by the addition of underdeck fireproofing. Class 2 constructions may also be acceptable if an approved sprinkler system is used.
- **Fire endurance tests.** These are time-temperature tests (ASTM E119) in which the roof-ceiling assembly is subjected to a rising heat load until either the interior structural elements yield, or the temperature on the exterior roof system reaches 139oC (250oF) above the ambient.
 - The minimum elapsed time required before the end point is reached is usually established by building code or occupancy (e.g., 1-hour, 1-1/2 hour, etc.).
 - Rated assemblies are listed by UL in their *Fire Resistance Directory* and by FM in their *Approval Guide*. Other testing agencies list rated assemblies in their directories as well.

- Assure that fire compliance (ratings) pertain to the entire assembly. Each component of the system must be listed in the above directories. Materials delivered to the job site should bear labels indicating compliance with the construction intended. The label also provides third party assurance that the products delivered to the construction site are essentially unchanged from those tested and listed.

10.9 Seismic Requirements. While membrane roofing materials in general do not affect seismic stability of a structure, components of the roof system may be important. Roof decks, for example, usually serve as a diaphragm increasing lateral stability.

10.9.1 Bracing for SSSMRs. Structural metal systems with floating clips require bracing since the structural standing seam metal panels do not provide diaphragm action. An alternative to bracing is to use a steel subdeck to serve as the shear diaphragm.

10.9.2 Inertia Effect. Heavy roofing materials such as ballast or pavers may result in an inertia effect that should be included in the design. This may be beneficial or detrimental.

10.9.3 Lateral Motion of Tiles. In steep roofing, seismic motion may shatter materials such as cement and clay tile. Correct use of mechanical anchors may prevent damage. Twisted wire systems are recommended for earthquake zones. The National Tile Roofing Manufacturers Association requires two nails or a nail and a clip on every tile to resist seismic damage.

10.9.4 Restraining Roof Tiles. IR-32-1 (9/89), a Title 24 California code addresses the attachment of tile, and allows the combination of wire tie and nose clips (wind locks or tile locks). Nails or wire ties are to be copper, brass, or stainless steel 11 ga. minimum with two per tile. Nails are to penetrate roof sheathing, battens, or support members 3/4 in. min. Ring shanked nails may be used when sheathing thickness is less than 3/4 in.

10.9.5 Parapet Walls. Parapet walls must be used with care. Through-wall flashings or cut reglets must be avoided as they reduce the wall's resistance to lateral forces.

10.9.6 Roofing Over Seismic Straps. Seismic straps (heavy metal plates) are sometimes installed over plywood roof decks and between decks and walls. Where roof insulation is not used (i.e., west coast capsheet construction), use construction details provided by the Western States Roofing Contractors Association on how to roof over the straps (Figure 18).

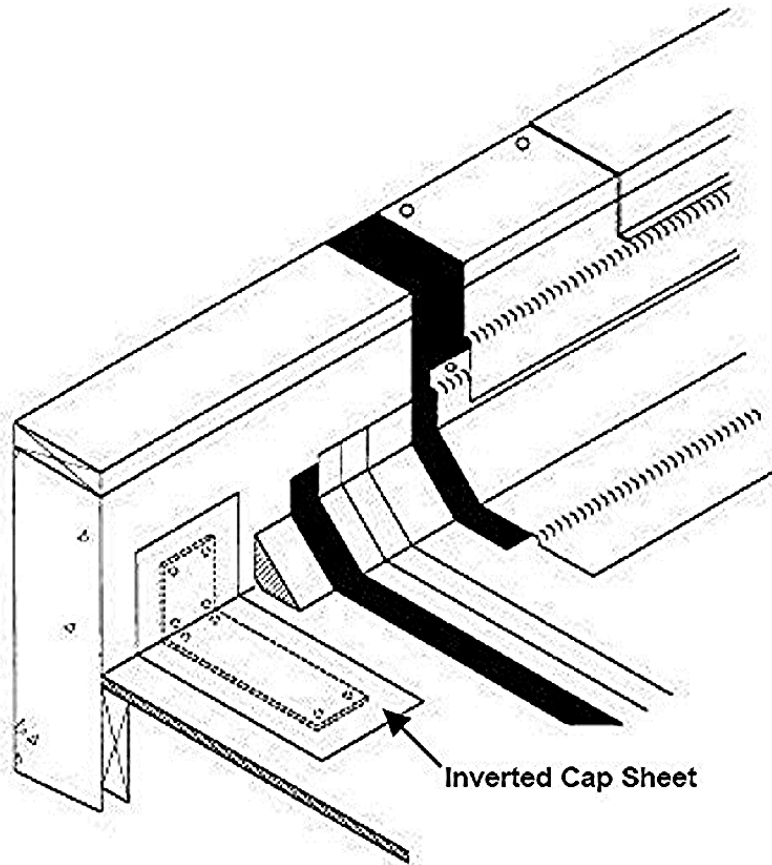

Roofing Over Thick Seismic Strap

Figure 18

10.10 Adequate Design Details. Complete sectional views of every location where the roof changes plane or there is a roof penetration or attachment should be provided on contract drawings. Sections and design details should be drawn to a legible scale with each element of the roofing system identified.