



**PDHonline Course C262 (5 PDH)**

---

# **Rock Blasting Fundamentals**

*Instructor: Daniel A. Vellone, M.S., P.G.*

2020

Information Circular 8925

# Explosives and Blasting Procedures Manual

By Richard A. Dick, Larry R. Fletcher,  
and Dennis V. D'Andrea



**UNITED STATES DEPARTMENT OF THE INTERIOR**

**James G. Watt, Secretary**

**BUREAU OF MINES**

**Robert C. Horton, Director**

**US Department of Interior**  
Office of Surface Mining  
Reclamation and Enforcement



**Kenneth K. Eltschlager**  
Mining/Blasting Engineer  
3 Parkway Center  
Pittsburgh, PA 15220

Phone 412.937.2169  
Fax 412.937.3012  
keltschl@osmre.gov

As the Nation's principal conservation agency, the Department of the Interior has responsibility for most of our nationally owned public lands and natural resources. This includes fostering the wisest use of our land and water resources, protecting our fish and wildlife, preserving the environmental and cultural values of our national parks and historical places, and providing for the enjoyment of life through outdoor recreation. The Department assesses our energy and mineral resources and works to assure that their development is in the best interests of all our people. The Department also has a major responsibility for American Indian reservation communities and for people who live in Island Territories under U.S. administration.

This publication has been cataloged as follows:

Dick, Richard A

Explosives and blasting procedures manual.

(Bureau of Mines Information circular ; 8925)

Supt. of Docs. no.: I 28.27:8925.

1. Blasting--Handbooks, manuals, etc. 2. Explosives--Handbooks, manuals, etc. I. Fletcher, Larry R. II. D'Andrea, Dennis V. III. Title. IV. Series: Information circular (United States. Bureau of Mines) ; 8925.

TN295,U4 [TN279] 622s [622'.23] 82-600353

## CONTENTS

	<i>Page</i>		<i>Page</i>
Abstract.....	1	Chapter 2.—Initiation and Priming—Con.	
Introduction .....	2	Priming.....	43
<b>Chapter 1.—Explosives Products</b>		Types of explosive used.....	43
Chemistry and physics of explosives .....	3	Primer makeup.....	45
Types of explosives and blasting agents .....	4	Primer location .....	46
Nitroglycerin-based high explosives .....	5	Multiple priming .....	47
Dry blasting agents.....	7	References.....	47
Slurries .....	9	<b>Chapter 3.—Blasthole Loading</b>	
Two-component explosives .....	10	Checking the blasthole.....	49
Permissible explosives.....	11	General loading procedures.....	49
Primers and boosters .....	11	Small-diameter blastholes.....	50
Liquid oxygen explosive and black powder .....	13	Cartridged products.....	50
Properties of explosives.....	14	Bulk dry blasting agents .....	50
Strength.....	14	Bulk slurries.....	52
Detonation velocity .....	14	Permissible blasting .....	52
Density .....	14	Large-diameter blastholes.....	52
Water resistance .....	15	Packaged products.....	52
Fume class .....	15	Bulk dry blasting agents .....	53
Detonation pressure .....	16	Bulk slurries.....	54
Borehole pressure.....	16	References.....	56
Sensitivity and sensitiveness.....	16	<b>Chapter 4.—Blast Design</b>	
Explosive selection criteria.....	17	Properties and geology of the rock mass.....	57
Explosive cost .....	17	Characterizing the rock mass .....	57
Charge diameter.....	18	Rock density and hardness .....	57
Cost of drilling.....	18	Voids and incompetent zones .....	57
Fragmentation difficulties.....	18	Jointing.....	58
Water conditions.....	18	Bedding .....	58
Adequacy of ventilation .....	18	Surface blasting .....	59
Atmospheric temperature .....	19	Blasthole diameter.....	59
Propagating ground.....	19	Types of blast patterns .....	61
Storage considerations.....	19	Burden.....	61
Sensitivity considerations .....	19	Subdrilling.....	62
Explosive atmospheres .....	20	Collar distance (stemming).....	62
References.....	20	Spacing .....	63
<b>Chapter 2.—Initiation and Priming</b>		Hole depth.....	64
Initiation systems .....	21	Delays .....	64
Delay series .....	21	Powder factor .....	65
Electric initiation .....	22	Secondary blasting.....	65
Types of circuits .....	23	Underground blasting.....	66
Circuit calculations .....	25	Opening cuts .....	66
Power sources.....	25	Blasting rounds.....	68
Circuit testing.....	28	Delays .....	69
Extraneous electricity .....	30	Powder factor .....	70
Additional considerations.....	30	Underground coal mine blasting .....	70
Detonating cord initiation .....	30	Controlled blasting techniques.....	70
Detonating cord products .....	31	Line drilling .....	70
Field application .....	31	Presplitting.....	71
Delay systems .....	33	Smooth blasting.....	73
General considerations .....	34	Cushion blasting.....	74
Detaline system.....	34	References.....	74
Cap-and-fuse initiation .....	35	<b>Chapter 5.—Environmental Effects of Blasting</b>	
Components .....	35	Flyrock .....	77
Field applications.....	35	Causes and alleviation .....	77
Delays .....	36	Protective measures.....	77
General considerations .....	36		
Other nonelectric initiation systems .....	36		
Hercudet.....	37		
Nonel.....	39		

	Page		Page
Chapter 5.—Environmental Effects of Blasting—Con.		Chapter 6.—Blasting Safety—Con.	
Ground vibrations.....	77	Transportation from magazine to jobsite.....	85
Causes .....	78	Precautions before loading .....	86
Prescribed vibration levels and measurement techniques.....	79	Primer preparation .....	88
Scaled distance equation .....	80	Borehole loading .....	88
Reducing ground vibrations.....	80	Hooking up the shot .....	90
Airblast.....	80	Shot firing.....	90
Causes .....	81	Postshot safety .....	92
Prescribed airblast levels and measurement techniques .....	82	Disposing of misfires.....	92
Reducing airblast.....	82	Disposal of explosive materials.....	92
Dust and gases.....	83	Principal causes of blasting accidents .....	92
References.....	83	Underground coal mine blasting .....	93
		References.....	93
Chapter 6.—Blasting Safety		Bibliography .....	94
Explosives storage.....	85	Appendix A.—Federal blasting regulations .....	96
		Appendix B.—Glossary of terms used in explosives and blasting.....	99

## ILLUSTRATIONS

1. Energy released by common products of detonation .....	3
2. Pressure profiles created by detonation in a borehole.....	4
3. Relative ingredients and properties of nitroglycerin-based high explosives.....	5
4. Typical cartridges of dynamite.....	6
5. Types of dry blasting agents and their ingredients .....	7
6. Porous ammonium nitrate prills .....	8
7. Water-resistant packages of AN-FO for use in wet boreholes.....	9
8. Formulations of water-based products .....	10
9. Slurry bulk loading trucks .....	11
10. Loading slurry-filled polyethylene bags.....	12
11. Cast primers for blasting caps and detonating cord .....	13
12. Delay cast primer .....	13
13. Effect of charge diameter on detonation velocity.....	14
14. Nomograph for finding loading density .....	15
15. Nomograph for finding detonation pressure .....	16
16. Field mixing of AN-FO .....	17
17. Instantaneous detonator.....	21
18. Delay detonator .....	22
19. Electric blasting caps.....	23
20. Delay electric blasting cap.....	23
21. Types of electric blasting circuits.....	24
22. Recommended wire splices.....	24
23. Calculation of cap circuit resistance .....	25
24. Capacitor discharge blasting machine.....	26
25. Sequential blasting machine.....	27
26. Blasting galvanometer.....	28
27. Blasting multimeter .....	29
28. Detonating cord.....	31
29. Clip-on surface detonating cord delay connector .....	32
30. Nonel surface detonating cord delay connector .....	32
31. Recommended knots for detonating cord.....	33
32. Potential cutoffs from slack and tight detonating cord lines .....	33
33. Typical blast pattern with surface delay connectors .....	33
34. Misfire caused by cutoff from burden movement.....	34
35. Blasting cap for use with safety fuse .....	35
36. Cap, fuse, and Ignitacord assembly .....	36
37. Hercudet blasting cap with 4-in tubes.....	37
38. Extending Hercudet leads with duplex tubing.....	38
39. Hercudet connections for surface blasting.....	38
40. Hercudet pressure test module .....	39

## ILLUSTRATIONS—Continued

41. Hercudet tester for small hookups .....	40
42. Hercules bottle box and blasting machine .....	41
43. Nonel blasting cap .....	41
44. Nonel Primadet cap for surface blasting .....	42
45. Nonel noiseless trunkline delay unit .....	42
46. Noiseless trunkline using Nonel delay assemblies .....	42
47. Nonel noiseless lead-in line .....	43
48. Highly aluminized AN-FO booster .....	44
49. Cartridge primed with electric blasting cap .....	45
50. Priming cast primer with electric blasting cap .....	46
51. Priming blasting agents in large-diameter blastholes .....	47
52. Corrective measures for voids .....	49
53. Pneumatic loading of AN-FO underground .....	51
54. Ejector-type pneumatic AN-FO loader .....	51
55. AN-FO detonation velocity as a function of charge diameter and density .....	52
56. Pouring slurry into small-diameter borehole .....	53
57. Pumping slurry into small-diameter borehole .....	54
58. Slurry leaving end of loading hose .....	55
59. Loss of explosive energy through zones of weakness .....	58
60. Effect of jointing on the stability of an excavation .....	58
61. Tight and open corners caused by jointing .....	58
62. Stemming through weak material and open beds .....	59
63. Two methods of breaking a hard collar zone .....	59
64. Effect of dipping beds on slope stability and potential toe problems .....	59
65. Effect of large and small blastholes on unit costs .....	60
66. Effect of jointing on selection of blasthole size .....	60
67. Three basic types of drill pattern .....	61
68. Corner cut staggered blast pattern—simultaneous initiation within rows .....	61
69. V-echelon blast round .....	61
70. Isometric view of a bench blast .....	61
71. Comparison of a 12¼-in-diameter blasthole (stiff burden) with a 6-in-diameter blasthole (flexible burden) in a 40-ft bench .....	62
72. Effects of insufficient and excessive spacing .....	63
73. Staggered blast pattern with alternate delays .....	63
74. Staggered blast pattern with progressive delays .....	63
75. The effect of inadequate delays between rows .....	64
76. Types of opening cuts .....	66
77. Six designs for parallel hole cuts .....	67
78. Drill template for parallel hole cut .....	67
79. Blast round for soft material using a sawed kerf .....	68
80. Nomenclature for blastholes in a heading round .....	68
81. Angled cut blast rounds .....	68
82. Parallel hole cut blast rounds .....	68
83. Fragmentation and shape of muckpile as a function of type of cut .....	69
84. Fragmentation and shape of muckpile as a function of delay .....	69
85. Typical burn cut blast round delay pattern .....	69
86. Typical V-cut blast round delay pattern .....	69
87. Shape of muckpile as a function of order of firing .....	69
88. Stable slope produced by controlled blasting .....	71
89. Crack generated by a presplit blast .....	72
90. Three typical blasthole loads for presplitting .....	73
91. Typical smooth blasting pattern .....	73
92. Mining near a residential structure .....	75
93. Example of a blasting record .....	76
94. Seismograph for measuring ground vibrations from blasting .....	78
95. Effects of confinement on vibration levels .....	79
96. Effect of delay sequence on particle velocity .....	79
97. Blasting seismograph with microphone for measuring airblast .....	81
98. Causes of airblast .....	81
99. Proper stacking of explosives .....	86
100. AN-FO bulk storage facility .....	87

## ILLUSTRATIONS—Continued

101. Checking the rise of the AN-FO column with a weighted tape.....	89
102. Blasting shelter.....	91

## TABLES

1. Properties of nitroglycerin-based explosives.....	5
2. Fume classes designated by the Institute of Makers of Explosives.....	15
3. Characteristics of pneumatically loaded AN-FO in small-diameter blastholes.....	52
4. Approximate B/D ratios for bench blasting.....	62
5. Approximate J/B ratios for bench blasting.....	62
6. Typical powder factors for surface blasting.....	65
7. Average specifications for line drilling.....	71
8. Average specifications for presplitting.....	73
9. Average specifications for smooth blasting.....	73
10. Average specifications for cushion blasting.....	74
11. Maximum recommended airblast levels.....	82
A-1. Federal regulatory agency responsibility.....	96

## UNIT OF MEASURE ABBREVIATIONS USED IN THIS REPORT

amp	ampere	ft	foot	min	minute
cm	centimeter	g	gram	ms	millisecond
cu cm	cubic centimeter	gr	grain	pct	percent
cu ft	cubic foot	Hz	hertz	ppm	parts per million
cu yd	cubic yard	in	inch	psi	pound per square inch
dB	decibel	kb	kilobar	sec	second
°	degree	kcal	kilocalorie	sq ft	square foot
° F	degree Fahrenheit	lb	pound	sq in	square inch
fps	foot per second	mi	mile	yd	yard

# EXPLOSIVES AND BLASTING PROCEDURES MANUAL

By Richard A. Dick,<sup>1</sup> Larry R. Fletcher,<sup>2</sup> and Dennis V. D'Andrea<sup>3</sup>

---

## ABSTRACT

This Bureau of Mines report covers the latest technology in explosives and blasting procedures. It includes information and procedures developed by Bureau research, explosives manufacturers, and the mining industry. It is intended for use as a guide in developing training programs and also to provide experienced blasters an update on the latest state of technology in the broad field of explosives and blasting.

Types of explosives and blasting agents and their key explosive and physical properties are discussed. Explosives selection criteria are described. The features of the traditional initiation systems—electrical, detonating cord, and cap and fuse—are pointed out, and the newer nonelectric initiation systems are discussed. Various blasthole priming techniques are described. Blasthole loading of various explosive types is covered. Blast design, including geologic considerations, for both surface and underground blasting is detailed. Environmental effects of blasting such as flyrock and air and ground vibrations are discussed along with techniques of measuring and alleviating these undesirable side effects. Blasting safety procedures are detailed in the chronological order of the blasting process.

The various Federal blasting regulations are enumerated along with their Code of Federal Regulations citations. An extensive glossary of blasting related terms is included along with references to articles providing more detailed information on the aforementioned items. Emphasis in the report has been placed on practical considerations.

---

<sup>1</sup>Mining engineer, Twin Cities Research Center, Bureau of Mines, Minneapolis, MN.

<sup>2</sup>Mining engineering technician, Twin Cities Research Center, Bureau of Mines, Minneapolis, MN.

<sup>3</sup>Supervisory physical scientist, Twin Cities Research Center, Bureau of Mines, Minneapolis, MN.



## INTRODUCTION

The need for better and more widely available blasters' training has long been recognized in the blasting community. The Mine Safety and Health Administration (MSHA) of the Department of Labor requires health and safety training for blasters. In 1980, the Office of Surface Mining Reclamation and Enforcement (OSM), Department of the Interior, promulgated regulations for the certification of blasters in the area of environmental protection. These regulations are certain to have a positive influence on the level of training and competence of blasters. They will, however, present a problem to the mining industry. That problem is a scarcity of appropriate training material. Although numerous handbooks and textbooks are available (9, 24, 27, 29-30, 32, 46)<sup>4</sup> none are geared for use in training the broad spectrum of people involved in practical blasting. This manual is designed to fulfill that need.

It is appropriate that the Bureau of Mines prepare such a manual. Since its inception, the Bureau has been involved in all aspects of explosives and blasting research including productivity, health and safety, and environment, and has provided extensive technical assistance to industry and regulatory agencies in the promotion of good blasting practices.

This manual serves two basic functions. The first is to provide a source of individual study for the practical blaster. There are literally tens of thousands of people involved in blasting at mines in the country and there are not enough formal training courses available to reach the majority of them. The second function is to provide guidance to industry, consultants, and academic institutions in the preparation of practical training courses on blasting.

The manual has been broken down into a series of discrete topics to facilitate self-study and the preparation of training modules. Each section stands on its own. Each student or instructor can utilize only those sections that suit his or her needs. An attempt has been made to provide concise, yet comprehensive coverage of the broad field of blasting technology. Although liberal use has been made of both Bureau and non-Bureau literature in preparation of this manual, none of the topics are dealt with in the depth that would be provided by a textbook or by a publication dealing with a specific topic. Each section is supplemented by references that can be used to pursue a more in-depth study. These references are limited to practical items that are of direct value to the blaster in the field. Theory is included only where it is essential to the understanding of a concept.

Where methods of accomplishing specific tasks are recommended, these should not be considered the only satisfactory methods. In many instances there is more than one safe, effective way to accomplish a specific blasting task.

None of the material in this manual is intended to replace manufacturers' recommendations on the use of the products involved. It is strongly recommended that the individual manufacturer be consulted on the proper use of specific products.

---

<sup>4</sup>Italicized numbers in parentheses refer to items in the bibliography preceding the appendixes.

## Chapter 1.—EXPLOSIVES PRODUCTS

### CHEMISTRY AND PHYSICS OF EXPLOSIVES

It is not essential that a blaster have a strong knowledge of chemistry and physics. However, a brief discussion of the reactions of explosives will be helpful in understanding how the energy required to break rock is developed.

An explosive is a chemical compound or mixture of compounds that undergoes a very rapid decomposition when initiated by energy in the form of heat, impact, friction, or shock (4)<sup>1</sup>. This decomposition produces more stable substances, mostly gases, and a large amount of heat. The very hot gases produce extremely high pressures within the borehole, and it is these pressures that cause the rock to be fragmented. If the speed of reaction of the explosive is faster than the speed of sound in the explosive (detonation), the product is called a high explosive. If the reaction of the explosive is slower than the speed of sound in the explosive (deflagration), the product is called a low explosive.

The principal reacting ingredients in an explosive are fuels and oxidizers. Common fuels in commercial products include fuel oil, carbon, aluminum, TNT, smokeless powder, monomethylamine nitrate, and monoethanol amine nitrate. Fuels often perform a sensitizing function. Common explosive sensitizers are nitroglycerin, nitrostarch, aluminum, TNT, smokeless powder, monomethylamine nitrate, and monoethanol amine nitrate. Microballoons and aerating agents are sometimes added to enhance sensitivity. The most common oxidizer is ammonium nitrate, although sodium nitrate and calcium nitrate may also be used. Other ingredients of explosives include water, gums, thickeners and cross-linking agents used in slurries (11), gelatinizers, densifiers, antacids, stabilizers, absorbents, and flame retardants. In molecular explosives such as nitroglycerin, TNT, and PETN, the fuel and oxidizer are combined in the same compound.

Most ingredients of explosives are composed of the elements oxygen, nitrogen, hydrogen, and carbon. In addition, metallic elements such as aluminum are sometimes used. For explosive mixtures, energy release is optimized at zero oxygen balance (5). Zero oxygen balance is defined as the point at which a mixture has sufficient oxygen to completely oxidize all the fuels it contains but there is no excess oxygen to react with the nitrogen in the mixture to form nitrogen oxides.

Theoretically, at zero oxygen balance the gaseous products of detonation are H<sub>2</sub>O, CO<sub>2</sub>, and N<sub>2</sub>, although in reality small amounts of NO, CO, NH<sub>2</sub>, CH<sub>4</sub>, and other gases are generated. Figure 1 shows the energy released by some of the common products of detonation. Partial oxidation of carbon to carbon monoxide, which results from an oxygen deficiency, releases less heat than complete oxidation to carbon dioxide. The oxides of nitrogen, which are produced when there is excess oxygen, are "heat robbers;" that is, they absorb heat when generated. Free nitrogen, being an element, neither absorbs nor releases heat upon liberation.

It should be noted that the gases resulting from improper oxygen balance are not only inefficient in terms of heat energy released but are also poisonous. Although the oxidation of aluminum yields a solid, rather than a gaseous, product the

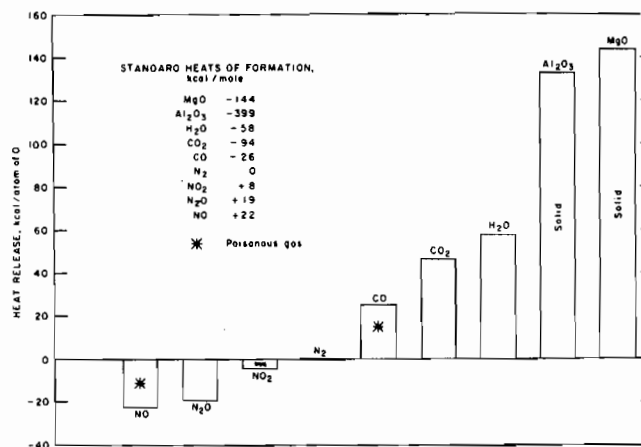
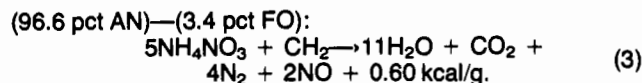
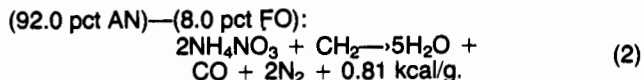
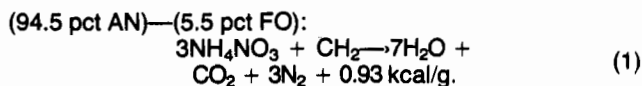

Figure 1.—Energy released by common products of detonation.

large amount of heat released adds significantly to the explosive's energy. Magnesium is even better from the standpoint of heat release, but is too sensitive to use in commercial explosives.

The principle of oxygen balance is best illustrated by the reaction of ammonium nitrate-fuel oil [(NH<sub>4</sub>NO<sub>3</sub>)-(CH<sub>2</sub>)<sub>n</sub>] mixtures. Commonly called AN-FO, these mixtures are the most widely used blasting agents. From the reaction equations for AN-FO, one can readily see the relationship between oxygen balance, detonation products, and heat release. The equations assume an ideal detonation reaction, which in turn assumes thorough mixing of ingredients, proper particle sizing, adequate confinement, charge diameter and priming, and protection from water. Fuel oil is actually a variable mixture of hydrocarbons and is not precisely CH<sub>2</sub>, but this identification simplifies the equations and is accurate enough for the purposes of this manual. In reviewing these equations, keep in mind that the amount of heat produced is a measure of the energy released.



Equation 1 represents the reaction of an oxygen-balanced mixture containing 94.5 pct AN and 5.5 pct FO. None of the detonation gases are poisonous and 0.93 kcal of heat is released for each gram of AN-FO detonated. In equation 2, representing a mixture of 92.0 pct AN and 8.0 pct FO, the excess fuel creates an oxygen deficiency. As a result, the

<sup>1</sup> Italicized numbers in parentheses refer to items in the list of references at the end of this chapter.

carbon in the fuel oil is oxidized only to CO, a poisonous gas, rather than relatively harmless CO<sub>2</sub>. Because of the lower heat of formation of CO, only 0.81 kcal of heat is released for each gram of AN-FO detonated. In equation 3, the mixture of 96.6 pct AN and 3.4 pct FO has a fuel shortage that creates an excess oxygen condition. Some of the nitrogen from the ammonium nitrate combines with this excess oxygen to form NO, which will react with oxygen in the atmosphere to form extremely toxic NO<sub>2</sub>. The heat absorbed by the formation of NO reduces the heat of reaction to only 0.60 kcal, which is considerably lower than that of an overfueled mixture. Also the CO produced by an overfueled mixture is less toxic than NO and NO<sub>2</sub>. For these reasons a slight oxygen deficiency is preferable and the common AN-FO mixture for field use is 94 pct AN and 6 pct FO.

Although the simple AN-FO mixture is optimum for highest energy release per unit cost of ingredients, products with higher energies and densities are often desired. The common high-energy producing additives, which may be used in both dry blasting agents and slurries, fall into two basic categories: explosives, such as TNT, and metals, such as aluminum. Equations 4 and 5 illustrate the reaction of TNT and aluminum as fuel-sensitizers with ammonium nitrate. The reaction products, again, assume ideal detonation, which is never actually attained in the field. In practice, aluminum is never the only fuel in the mixture, some carbonaceous fuel is always used.

(78.7 pct AN)—(21.3 pct TNT):

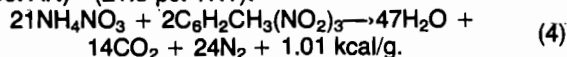

(81.6 pct AN)—(18.4 pct Al):

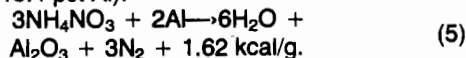

Both of these mixtures release more energy, based on weight, than ammonium nitrate-carbonaceous fuel mixtures and have the added benefit of higher densities. These advantages must be weighed against the higher cost of such high-energy additives. The energy of aluminized products continues to increase with larger percentages of metal, even though this "overfueling" causes an oxygen deficiency. Increasing energy by overfueling with metals, however, is uneconomical except for such specialty products as high-energy boosters.

The chemical reaction of an explosive creates extremely high pressures. It is these pressures which cause rock to be broken and displaced. To illustrate the pressures created in the borehole, a brief look will be taken at the detonation process as pictured by Dr. Richard Ash of the University of Missouri-Rolla. Figure 2, adapted from Ash's work shows (top) a column of explosive or blasting agent that has been initiated. Detonation has proceeded to the center of the column. The

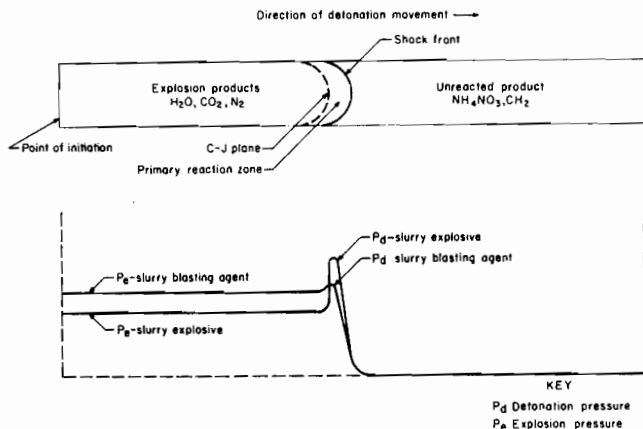

Figure 2.—Pressure profiles created by detonation in a borehole.

primary reaction occurs between a shock front at the leading edge and a rear boundary known as the Chapman-Jouguet (C-J) plane. Part of the reaction may occur behind the C-J plane, particularly if some of the explosive's ingredients are coarse. The length of the reaction zone, which depends on the explosive's ingredients, particle size, density, and confinement, determines the minimum diameter at which the explosive will function dependably (critical diameter). High explosives, which have short reaction zones, have smaller critical diameters than blasting agents.

The pressure profiles in figure 2 (bottom) show the explosive forces applied to the rock being blasted. A general comparison is given between an explosive and a blasting agent, although it should be understood that each explosive or blasting agent has its own particular pressure profile depending on its ingredients, particle size, density, and confinement.

The initial pressure, called the detonation pressure ( $P_d$ ), is created by the supersonic shock front moving out from the detonation zone. The detonation pressure gives the explosive its shattering action in the vicinity of the borehole. If the explosive reacts slower than the speed of sound, which is normally the case with black powder, there is no detonation pressure.

The detonation pressure is followed by a sustained pressure called explosion pressure ( $P_e$ ), or borehole pressure. Borehole pressure is created by the rapid expansion of the hot gases within the borehole. The detonation pressure of high explosives is often several times that of blasting agents, but the borehole pressures of the two types of products are of the same general magnitude. The relative importance of detonation pressure and borehole pressure in breaking rock will be discussed in the "Properties of Explosives" section of this chapter.

## TYPES OF EXPLOSIVES AND BLASTING AGENTS

This section will cover all explosive products that are used for industrial rock blasting, with the exception of initiators. Products used as the main borehole charge can be divided into three categories: nitroglycerin- (or nitrostarch-) based high explosives, dry blasting agents, and slurries, which may also be referred to as water gels or emulsions. These products can also be broadly categorized as explosives and blasting

agents. For ease of expression, the term explosives will often be used in this manual to collectively cover both explosives and blasting agents. The difference between an explosive and a blasting agent is as follows.

A high explosive is any product used in blasting that is sensitive to a No. 8 cap and that reacts at a speed faster than the speed of sound in the explosive medium. A low explosive

is a product in which the reaction is slower than the speed of sound. Low explosives are seldom used in blasting today. A blasting agent is any material or mixture consisting of a fuel and an oxidizer, intended for blasting, not otherwise classified as an explosive, provided that the finished product, as mixed and packaged for shipment, cannot be detonated by a No. 8 blasting cap in a specific test prescribed by the Bureau of Mines. Slurries containing TNT, smokeless powder, or other explosive ingredients, are classed as blasting agents if they are insensitive to a No. 8 blasting cap.

AN-FO, which in normal form is a blasting agent, can be made cap sensitive by pulverizing it to a fine particle size, and a slurry can be made cap sensitive by including a sufficient amount of finely flaked paint-grade aluminum. Although neither of these products contains an explosive ingredient, their cap sensitivity requires their being classified as explosives. The term nitrocarbonitrate, or NCN, was once used synonymously with blasting agent under U.S. Department of Transportation (DOT) regulations for packaging and shipping blasting agents. DOT no longer uses this term.

### NITROGLYCERIN-BASED HIGH EXPLOSIVES

Nitroglycerin-based explosives can be categorized as to their nitroglycerin content (4). Figure 3 shows this breakdown

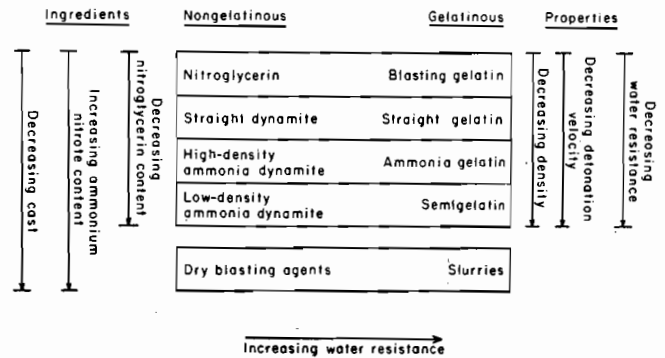

Figure 3.—Relative ingredients and properties of nitroglycerin-based high explosives.

along with some relative properties and ingredients of these products. Table 1 shows some properties of nitroglycerin-based explosives. Property values are averages of manufacturers' published figures. As a group, nitroglycerin-based explosives are the most sensitive commercial products used today (excluding detonators). Because of this sensitivity they offer an extra margin of dependability in the blasthole but are somewhat more susceptible to accidental detonation. This is a tradeoff that many operators using small-diameter boreholes

Table 1. - Properties of nitroglycerin-based explosives

Weight strength, pct	Bulk strength, pct	Specific gravity	Detonation velocity, fps	Water resistance	Fume class
STRAIGHT DYNAMITE					
50	50	1.4	17,000	Good.....	Poor.
HIGH-DENSITY AMMONIA DYNAMITE					
60	50	1.3	12,500	Fair.....	Good.
40	35	1.3	10,500	...do.....	Do.
20	15	1.3	8,000	...do.....	Do.
LOW-DENSITY AMMONIA DYNAMITE, HIGH VELOCITY					
65	50	1.2	11,000	Fair.....	Fair.
65	40	1.0	10,000	...do.....	Do.
65	30	.9	9,500	Poor.....	Do.
65	20	.8	8,500	...do.....	Do.
LOW-DENSITY AMMONIA DYNAMITE, LOW VELOCITY					
65	50	1.2	8,000	Fair.....	Fair.
65	40	1.0	7,500	Poor.....	Do.
65	30	.9	7,000	...do.....	Do.
65	20	.8	6,500	...do.....	Do.
BLASTING GELATIN					
100	90	1.3	25,000	Excellent.....	Poor.
STRAIGHT GELATIN					
90	80	1.3	23,000	Excellent.....	Poor.
60	60	1.4	20,000	...do.....	Good.
40	45	1.5	16,500	...do.....	Do.
20	30	1.7	11,000	...do.....	Do.
AMMONIA GELATIN					
80	70	1.3	20,000	Very good.....	Good.
60	60	1.4	17,500	...do.....	Very good.
40	45	1.5	16,000	...do.....	Do.
SEMIGELATIN					
65	60	1.3	12,000	Very good.....	Very good.
65	50	1.2	12,000	...do.....	Do.
65	40	1.1	11,500	Good.....	Do.
65	30	.9	10,500	Fair.....	Do.

must make. Nitroglycerin dynamites account for less than 5 pct, by weight, of the explosives market (12), and almost all of that is in small-diameter work. Dynamite is available in cartridges of various sizes and shapes, as shown in figure 4.

*Nitroglycerin (NG)*, the first high explosive, is the sensitizer in dynamites and is seldom used alone, although it has been used in a somewhat desensitized form for shooting oil wells. It has a specific gravity of 1.6 and a detonation velocity slightly

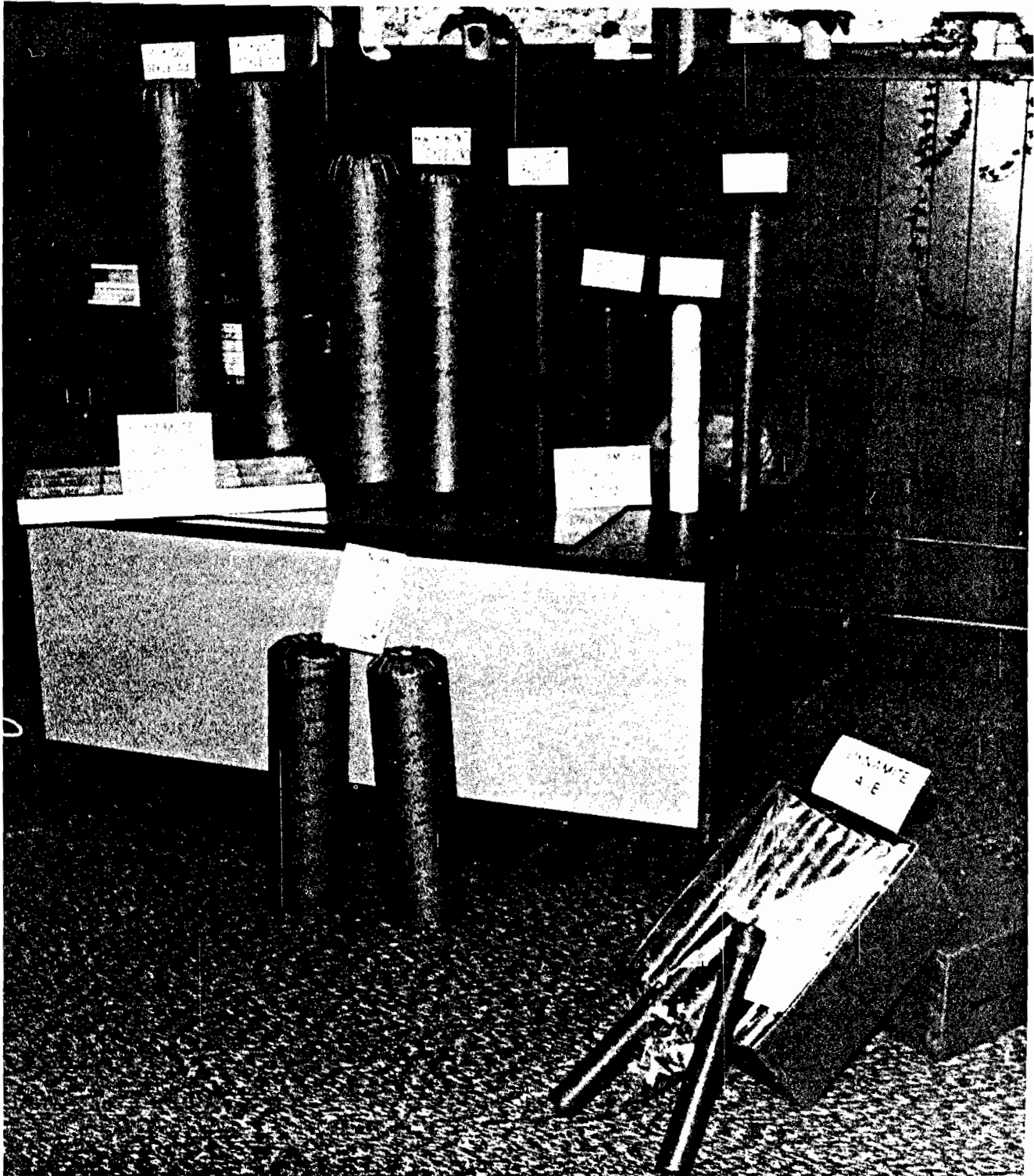

Figure 4.—Typical cartridges of dynamite. (Courtesy Atlas Powder Co.)

over 25,000 fps. Its extreme sensitivity to shock, friction, and heat make it hazardous to use.

*Straight (nitroglycerin) dynamite* consists of nitroglycerin, sodium nitrate, an antacid, a carbonaceous fuel, and sometimes sulfur. The term "straight" means that a dynamite contains no ammonium nitrate. The weight strength, usually 50 pct, indicates the approximate percentage of nitroglycerin or other explosive oil. The use of straight dynamite is limited because of its high cost and sensitivity to shock and friction. Fifty percent straight dynamite, by far the most common straight dynamite, is referred to as ditching dynamite and is used in propagation blasting.

*High-density ammonia dynamite*, also called extra dynamite, is the most widely used dynamite. It is like straight dynamite, except that ammonium nitrate replaces part of the nitroglycerin and sodium nitrate. Ammonia dynamite is manufactured in grades of 20 to 60 pct weight strength, although these grades are not truly equivalent to straight dynamites of the same weight strength (see properties in table 1). Ammonia dynamite is less sensitive to shock and friction than straight dynamite. It is most commonly used in small quarries, in underground mines, in construction, and as an agricultural explosive.

*Low-density ammonia dynamite* is manufactured in a weight strength of about 65 pct. The cartridge (bulk) strength ranges from 20 to 50 pct, depending on the bulk density of the ingredients. A high-velocity series and a low-velocity series are manufactured. Low-density ammonia dynamite is useful in very soft or prefractured rock or where coarse rock such as riprap is required.

*Blasting gelatin* is a tough, rubber-textured explosive made by adding nitrocellulose, also called guncotton, to nitroglycerin. An antacid is added to provide storage stability and wood meal is added to improve sensitivity. Blasting gelatin emits large volumes of noxious fumes upon detonation and is expensive. It is seldom used today. Sometimes called oil well explosive, it has been used in deep wells where high heads of water are encountered. Blasting gelatin is the most powerful nitroglycerin-based explosive.

*Straight gelatin* is basically a blasting gelatin with sodium nitrate, carbonaceous fuel, and sometimes sulfur added. It is manufactured in grades ranging from 20 to 90 pct weight strength and is the gelatinous equivalent of straight dynamite. Straight gelatin has been used mainly in specialty areas such as seismic or deep well work, where a lack of confinement or a high head of water may affect its velocity. To overcome these conditions a high-velocity gelatin is available which is like straight gelatin except that it detonates near its rated velocity despite high heads of water.

*Ammonia gelatin*, also called special gelatin or extra gelatin, is a straight gelatin in which ammonium nitrate has replaced part of the nitroglycerin and sodium nitrate. Manufactured in weight strengths ranging from 40 to 80 pct, it is the gelatinous equivalent of ammonia dynamite. Ammonia gelatin is suitable for underground work, in wet conditions, and as a toe load, primarily in small-diameter boreholes. The higher grades (70 pct or higher) are useful as primers for blasting agents.

*Semigelatin* has a weight strength near 65 pct. The cartridge (bulk) strength ranges from 30 to 60 pct with variations in the bulk density of the ingredients. Semigelatin is versatile and is used in small-diameter work where some water resistance is required. It is useful underground, where its soft, plastic consistency makes it ideal for loading into holes drilled upward.

*Nitrostarch explosives* are sensitized with nitrostarch, a solid molecular explosive, rather than an explosive oil. They are manufactured in various grades, strengths, densities, and degrees of water resistance to compete with most grades of nitroglycerin-based dynamites. They are similar to dynamites

in many ways with their most significant differences being somewhat higher impact resistance and their "headache-free" nature.

## DRY BLASTING AGENTS

In this manual, the term dry blasting agent describes any material used for blasting which is not cap sensitive and in which water is not used in the formulation. Figure 5 describes the dry blasting agents in use today.

Early dry blasting agents employed solid carbon fuels combined with ammonium nitrate in various forms. Through experimentation it was found that diesel fuel oil mixed with porous ammonium nitrate prills (fig. 6) gave the best blasting results. Hence, the term AN-FO (ammonium nitrate-fuel oil) has been synonymous with dry blasting agent. An oxygen-balanced AN-FO is the cheapest source of explosive energy available today. Adding finely divided or flaked aluminum to dry blasting agents increases the energy output but at an increase in cost. Aluminized dry mixes are sometimes used in combination with cast primers as primers for AN-FO. Aluminized mixes may also be used as a high-energy toe load and as the main column charge where blasting is difficult.

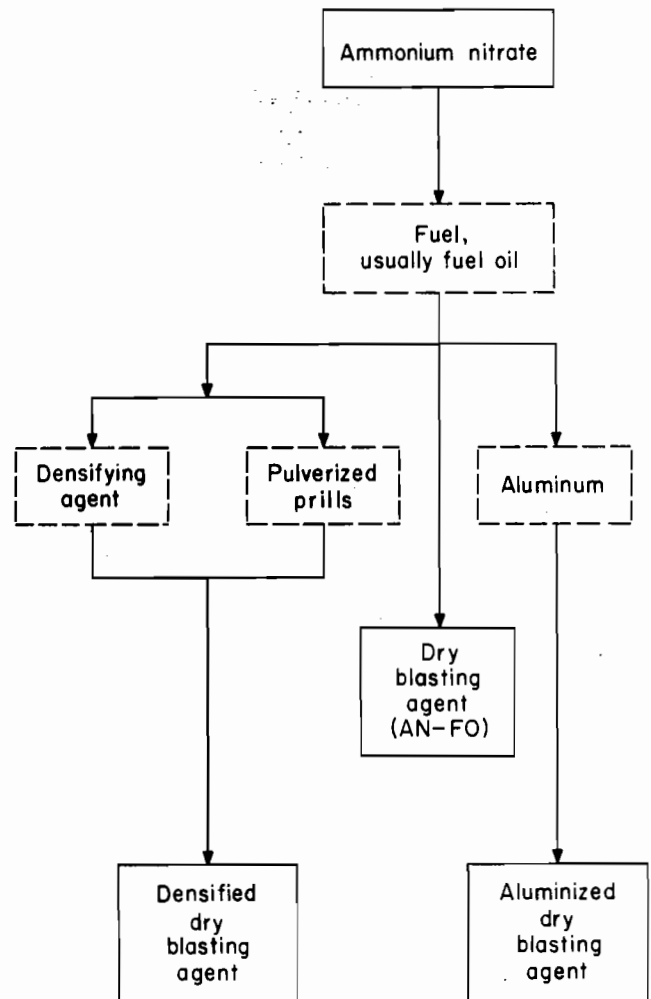

Figure 5.—Types of dry blasting agents and their ingredients.

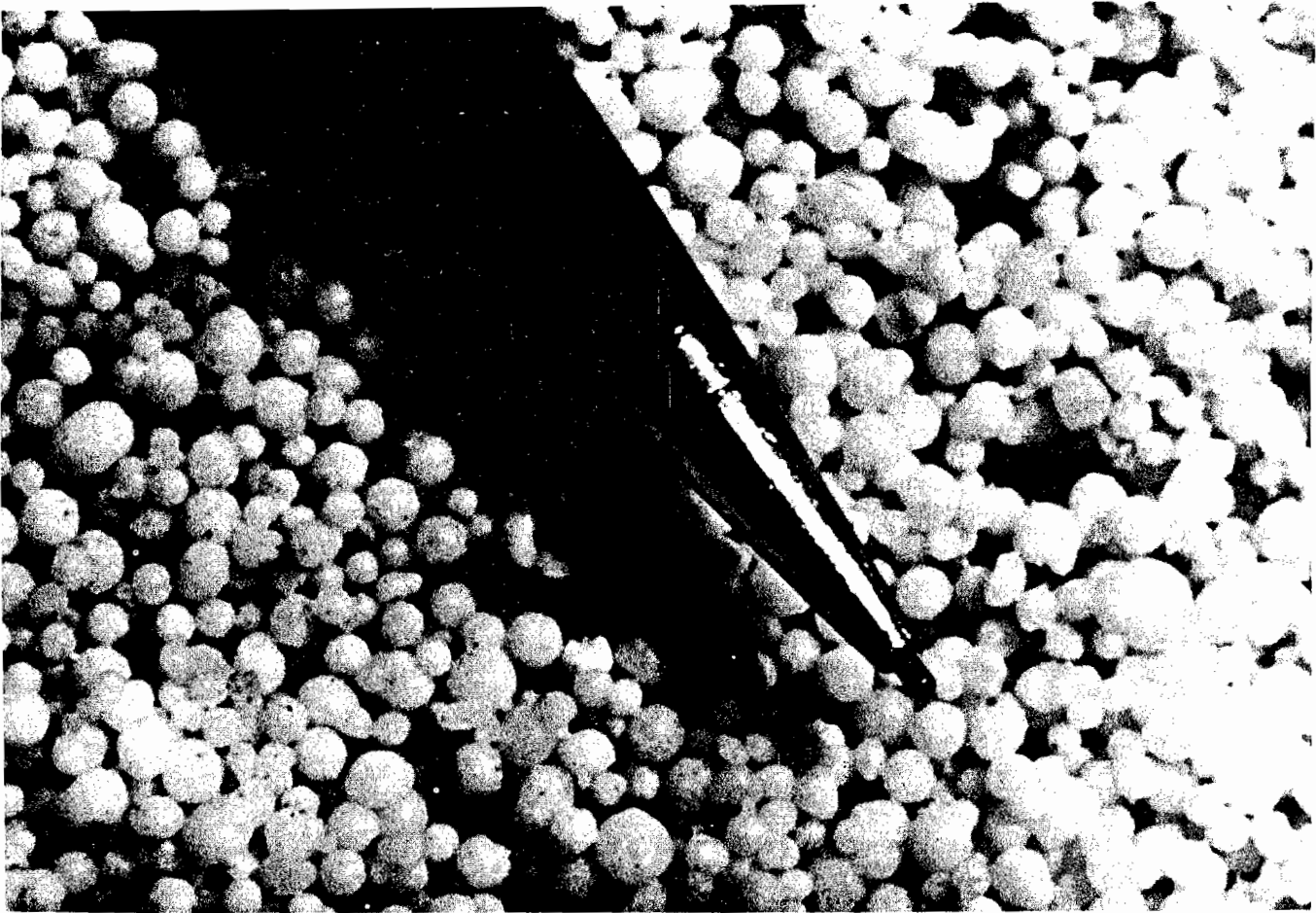

Figure 6.—Porous ammonium nitrate prills. (Courtesy Hercules Inc.)

It is difficult to give precise numerical values for the properties of dry blasting agents because the properties vary with ingredient particle size, density, confinement, charge diameter, water conditions, and coupling ratio (5). Yancik has prepared an excellent manual on explosive properties of AN-FO (9).

Coupling ratio is the percentage of the borehole diameter filled with explosive. Poured bulk products are completely coupled, which increases their efficiency. Cartridge products are partially decoupled, and thus lose some efficiency.

AN-FO's theoretical energy is optimized at oxygen balance (approximately 94.5 pct AN and 5.5 pct FO), where the detonation velocity approaches 15,000 fps in large charge diameters. Excess fuel oil (8 pct or more) can seriously reduce sensitivity to initiation. Inadequate fuel oil causes an excess of harmful nitrogen oxide fumes in the detonation gases. Specific gravities of AN-FO range from 0.5 to 1.15; 0.80 to 0.85 is the most common range. The lighter products are useful in easily fragmented rock or to eliminate the need for alternate decks of explosive and stemming where a low powder factor is desirable. The densified dry mixes are packaged in waterproof containers for use in wet blastholes (fig. 7).

Densification is necessary to enable the cartridges to sink in water. To obtain a higher specific gravity, part of the prills are pulverized and then the mixture of whole and pulverized prills is vibrated or otherwise compressed into rigid cartridges or

polyburlap bags. Densifying ingredients, such as ferrosilicon, are seldom used today because they add little or nothing to the explosive's energy. The sensitivity of AN-FO decreases with increased density. The "dead press" limit, above which detonation is undependable, is about 1.25 g/cu cm.

The detonation velocity of AN-FO is strongly affected by charge diameter. The critical diameter is near 1 in with a normal prill and oil mixture. The velocity increases with diameter and levels off near a 15-in diameter at a velocity of nearly 15,000 fps. The minimum primer required for AN-FO increases as charge diameter increases. There is a tendency to underprime in large-diameter boreholes. A good rule of thumb is, when in doubt, overprime. Many operators claim improved results when they use primers that fill, or nearly fill, the blasthole diameter.

The undesirable effect of water on dry blasting agents has often been seen in poor blasts where AN-FO was used in wet boreholes with insufficient external protection. Excess water adversely affects the velocity, sensitivity, fume class, and energy output of a dry blasting agent. The extreme result is a misfire. It is essential when using AN-FO in wet conditions that positive protection in the form of a waterproof package or a borehole liner be used (3).

Dry blasting agents can be purchased in four forms. In increasing order of cost they are as follows:



Figure 7.—Water-resistant packages of AN-FO for use in wet boreholes. (Courtesy Gulf Oil Chemicals Co.)

1. As separate ingredients in bulk form for onsite mixing
2. Premixed in bulk form for onsite storage or direct borehole delivery (a premixed product may cost about the same as separate ingredients).
3. In paper or polyethylene packages for pouring into the borehole.
4. In waterproof cartridges or polyburlap containers.

Waterproof containers are the most expensive forms and eliminate the advantage of direct borehole coupling. They should be used only where borehole conditions dictate. Because improper ingredient proportions or an insufficiently mixed product cause inefficient detonation and poor fume qualities, thorough mixing and close quality control should be exercised in an onsite mixing operation. The use of a colored dye in the fuel gives a visual check on mixing and also makes the blasting agent more easily visible in case of misfire.

Recent trials in taconite mines have employed a dense dry blasting agent composed of 87 pct crushed ammonium nitrate prills and 13 pct of a 50-50 mixture of nitropropane and methanol. This product has slightly more energy per unit weight than AN-FO and can be loaded at a density of approximately 1.2 g/cu cm, giving it a high energy density. Because of the experimental nature of this product, MSHA should be consulted before putting it to use.

## SLURRIES

A slurry (fig.8) is a mixture of nitrates such as ammonium nitrate and sodium nitrate, a fuel sensitizer, either explosive or nonexplosive, and varying amounts of water (7). A water gel is essentially the same as a slurry and the two terms are frequently used interchangeably. An emulsion is somewhat different from a water gel or slurry in physical character but similar in many functional respects. The principal differences are an emulsion's generally higher detonation velocity and a tendency to wet or adhere to the blasthole, which in some cases may affect its bulk loading characteristics. In this discussion, slurries, water gels, and emulsions will be treated as a family of products.

Although they contain large amounts of ammonium nitrate, slurries are made water resistant through the use of gums, waxes, and cross-linking agents. The variety of possible slurry formulations is almost infinite. Frequently a slurry is specially formulated for a specific job. The list of possible fuel sensitizers is especially long (11), although carbonaceous fuels, aluminum, and amine nitrates are the most common.

Slurries may be classified as either explosives or blasting agents. Those that are sensitive to a No. 8 cap are classified as explosives, even though they are less sensitive than dynamites. It is important that slurries be stored in magazines appropriate to their classification.



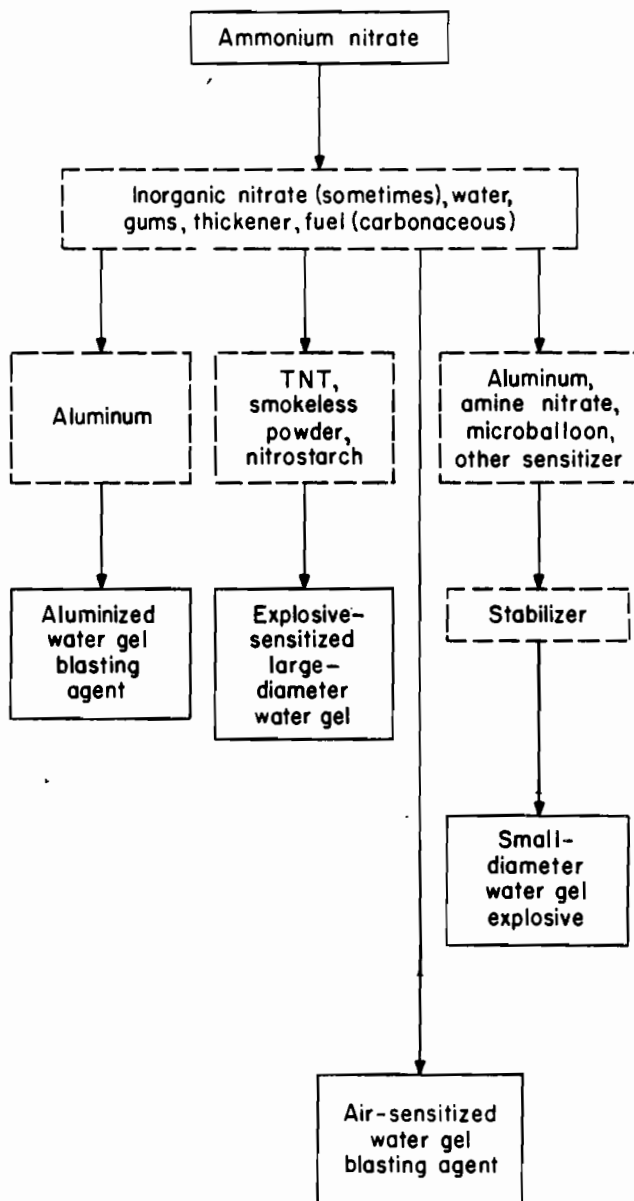

Figure 8.—Formulations of water-based products.

Except for their excellent water resistance and higher density and bulk strength, slurries are similar in many ways to dry blasting agents. Good oxygen balance, decreased particle size and increased density, increased charge diameter, good confinement and coupling, and adequate priming all increase their efficiency. Although slurry blasting agents tend to lose sensitivity as their density increases, some explosive-based slurries function well at densities up to 1.6. The effect of charge diameter on the detonation velocity of slurries is not as pronounced as it is on AN-FO.

Most non-cap-sensitive slurries depend on entrapped air for their sensitivity and most cap-sensitive varieties are also dependent, to a lesser degree, on this entrapped air. If this air is removed from a slurry through pressure from an adjacent blast, prolonged periods of time in the borehole, or prolonged storage, the slurry may become desensitized.

Slurries can be delivered as separate ingredients for onsite mixing, premixed for bulk loading (fig. 9), in polyethylene bags for bulk loading or loading in the bag (fig. 10), or they may be cartridged. Their consistency may be anywhere from a liquid to a cohesive gel.

Cartridged slurries for use in small-diameter blastholes (2-in diameter or less) are normally made cap sensitive so they can be substituted for dynamites. However, their lower sensitivity as compared with dynamite should be kept in mind. The sensitivity and performance of some grades of slurries are adversely affected by low temperatures. Slurries designed for use in medium-diameter blastholes (2- to 5-in diameters) may be cap sensitive but they often are not. Those that are not cap sensitive must be primed with a cap-sensitive explosive. Slurries for use in large diameters (greater than 5 in) are the least sensitive slurries.

Slurries containing neither aluminum nor explosive sensitizers are the cheapest, but they are also the least dense and powerful. In wet conditions where dewatering is not practical, and the rock is not extremely difficult to fragment, these low-cost slurries offer competition to AN-FO.

Aluminized slurries or those containing significant amounts of other high-energy sensitizers, develop sufficient energy for blasting in hard, dense rock. However, the economics of using total column charges of highly aluminized slurry are doubtful because of the significantly higher cost of these products. High-energy slurries have improved blasting efficiency when used in combination with the primer at the toe or in another zone of difficult breakage.

Detonating cord downlines can have a harmful effect on the efficiency of blasting agent slurries, depending on the size of the blasthole and the strength of the cord. When using detonating cord downlines, the slurry manufacturer should be consulted concerning the effect of the cord on the slurry.

The technology of slurries is very dynamic. New products are continually being developed. The blaster should check the technical literature to be aware of developments that affect his or her blasting program.

## TWO-COMPONENT EXPLOSIVES

Individually, the components of two-component explosives, also called binary explosives, are not classified as explosives. When shipped and stored separately they are not normally regulated as explosives, but they should be protected from theft. However, some organizations such as the U.S. Forest Service, and some State and local government agencies, may treat these components as explosives for storage purposes.

The most common two-component explosive is a mixture of pulverized ammonium nitrate and nitromethane, although other fuel sensitizers such as rocket fuel have been used. The components are carried in separate containers to the jobsite, where the container of liquid fuel is poured into the ammonium nitrate container. After the prescribed waiting time the mixture becomes cap sensitive and is ready for use.

Two-component explosives are sometimes used where only small amounts of explosives are required such as in powerline installation and light construction. Where large amounts of explosives are needed, the higher cost per pound and the inconvenience of onsite mixing negate the savings and convenience realized through less stringent storage and distribution requirements. In some States, for example Pennsylvania, the user of two-component explosives is considered a manufacturer and must obtain a manufacturer's license.



Figure 9.—Slurry bulk loading trucks. (Courtesy Gulf Oil Chemicals Co.)

## PERMISSIBLE EXPLOSIVES

Permissible explosives are designed for use in underground coal mines, where the presence of explosive gases or dust presents an abnormal blasting hazard. Both nitroglycerin-based permissibles and slurry, water gel, and emulsion permissibles are available. Briefly stated, the specifications of a permissible explosive are as follows:

1. The chemical composition furnished by the applicant must agree, within tolerance, with that determined by MSHA.
2. The explosive must pass a series of propagation tests.
3. The airgap sensitivity of 1¼-in cartridges must be at least 3 in.
4. The explosive must pass nonignition tests when fired unstemmed into a mixture of natural gas, air, and bituminous coal dust.
5. The explosive must pass tests for nonignition when fired stemmed in a gallery of air and natural gas.
6. The volume of poisonous gases produced by a pound of explosive must not exceed 2.5 cu ft.
7. The explosive must exhibit insensitivity in the pendulum friction test.

Permissible explosives must be used in a permissible manner, as described briefly in the "Underground Coal Mine Blasting" section of chapter 4. MSHA must also approve explosives used in gassy noncoal mines. For gassy noncoal mines, MSHA sometimes approves products such as AN-FO, and specifies the manner in which they are to be used.

Sodium chloride or other flame depressants are used in permissible explosives to minimize the chance of igniting the mine atmosphere. As a result, permissible explosives are less energetic than other explosives and have a lower rock-breaking capability. They should be used only where required by a gassy atmosphere. Permissible explosives are allowed to generate more fumes than other explosives, but most do not. MSHA periodically publishes an up-dated list of brand names and properties of permissible explosives (14).

## PRIMERS AND BOOSTERS

The terms "primer" and "booster" are often confused. According to MSHA a primer, sometimes called a capped primer, is a unit of cap-sensitive explosive used to initiate other explosives or blasting agents. A primer contains a detonator. A booster is



**Figure 10.—Loading slurry-filled polyethylene bags. (Courtesy Atlas Powder Co.)**

often, but not always, cap sensitive, but does not contain a detonator. A booster is used to perpetuate or intensify an explosive reaction.

Although various products have been used as primers and boosters, an explosive with a high detonation pressure such as a high-strength ammonia gelatin or a cast military explosive (composition B or pentolite) (fig. 11) is recommended. Cast

primers have a sensitive inner core that will accept detonation from a detonator or detonating cord, but are quite insensitive to external shock or friction. Cast primers are available which have built-in millisecond delay units (fig. 12). These primers, when strung on a single detonating cord downline, enable the blaster to place as many delayed decks in the blasthole as the blast design requires.

CAST PRIMER FOR  
DETONATING CORD

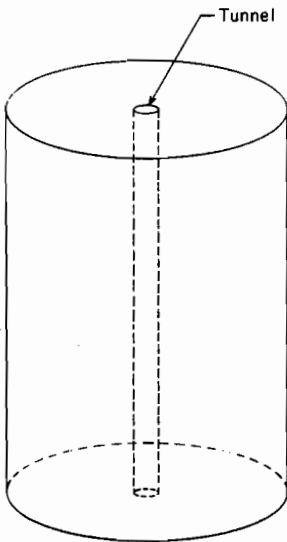

CAST PRIMER FOR  
BLASTING CAP

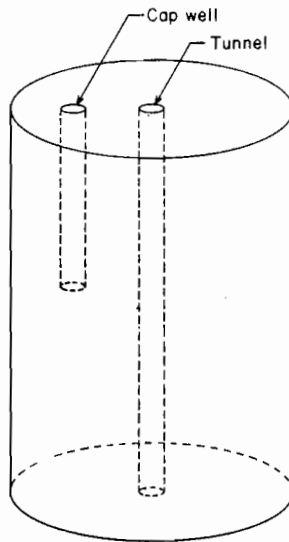

Figure 11.—Cast primers for blasting caps and detonating cord.

Although small 1-lb cast primers are popular, even in large boreholes, a primer functions best when its diameter is near that of the borehole. A two-stage primer, with a charge of high-energy dry blasting agent or slurry poured around a cast primer or ammonia gelatin, is frequently used in large-diameter blastholes. In Sweden, in small-diameter work, excellent results have been reported with a high-strength blasting cap used to initiate AN-FO, thus eliminating the need for a primer. In the United States, a more common practice in small-diameter work is to use a small primer designed to fit directly over a blasting cap, or a small cartridge of ammonia gelatin. More detailed priming recommendations are given in chapter 2.

### LIQUID OXYGEN EXPLOSIVE AND BLACK POWDER

Liquid oxygen explosive (LOX) and black powder merit a brief mention because of their past importance. LOX consists of a cartridge of lampblack, carbon black, or charcoal, dipped into liquid oxygen just before loading. It derives its energy from the reaction of the carbon and oxygen to form carbon dioxide. LOX is fired with an ordinary detonator and attains velocities of 12,000 to 19,000 fps. LOX, primarily used in U.S. strip coal mining, has been replaced by blasting agents, although it is still used in foreign countries.

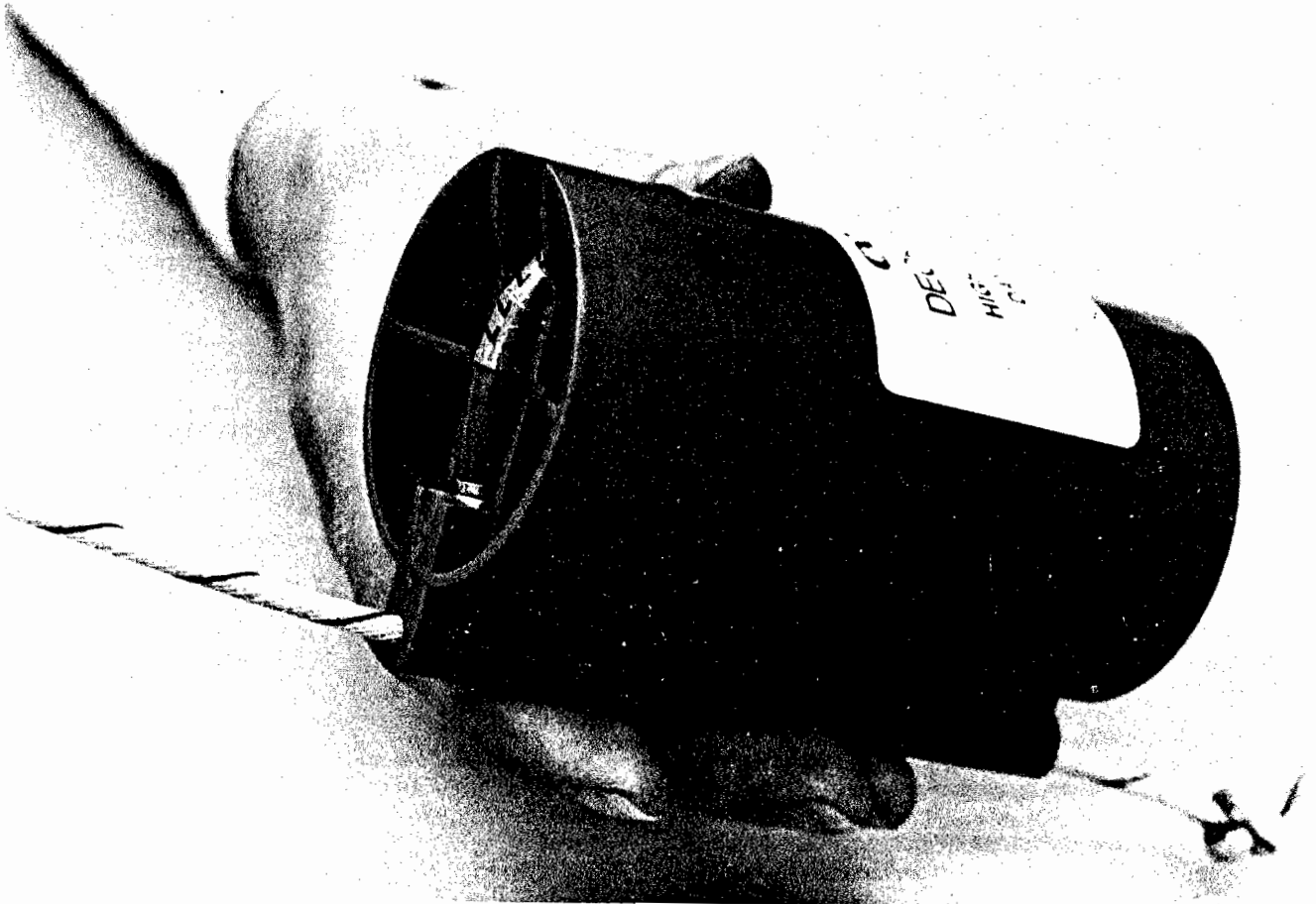

Figure 12.—Delay cast primer. (Courtesy Atlas Powder Co.)

Black powder, a mixture of potassium or sodium nitrate, charcoal, and sulfur, dates from ancient times. Once the principal commercial explosive, black powder is extremely prone to accidental initiation by flame or spark. When initiated, it undergoes burning at a very rapid rate. This rapid burning, called deflagration, is much slower than typical detonation velocities. Black powder

has a specific gravity of 1.6 or less, depending on granulation, has poor water resistance, and emits large volumes of noxious gases upon deflagration. Black powder finds limited use in blasting dimension stone where a minimum of shattering effect is desired. It is not an efficient explosive for fragmenting rock.

## PROPERTIES OF EXPLOSIVES

Explosives and blasting agents are characterized by various properties that determine how they will function under field conditions. Properties of explosives which are particularly important to the blaster include "strength," detonation velocity, density, water resistance, fume class, detonation pressure, borehole pressure, and sensitivity and sensitiveness. Numerous other properties can be specified for explosives but have not been included here because of their lack of importance to the field blaster.

### STRENGTH

The strength of explosives has been expressed in various terms since the invention of dynamite. The terms "weight strength" and "cartridge strength," which originally indicated the percentage of nitroglycerin in an explosive, were useful when nitroglycerin was the principal energy-producing ingredient in explosives. However, with the development of products with decreasing proportions of nitroglycerin, these strength ratings have become misleading and inaccurate (4) and do not realistically compare the effectiveness of various explosives.

More recently, calculated energy values have been used to compare the strengths of explosives with AN-FO being used as a base of 1.0. Although this system has not been universally adopted, it is an improvement over weight strength and cartridge strength in estimating the work an explosive will do. Other strength rating systems such as seismic execution value, strain pulse measurement, cratering, and the ballistic mortar have been used, but do not give a satisfactory prediction of the field performance of an explosive.

Underwater tests have been used to determine the shock energy and expanding gas energy of an explosive. These two energy values have been used quite successfully by explosive manufacturers in predicting the capability of an explosive to break rock.

### DETONATION VELOCITY

Detonation velocity is the speed at which the detonation front moves through a column of explosives. It ranges from about 5,500 to 25,000 fps for products used commercially today. A high detonation velocity gives the shattering action that many experts feel is necessary for difficult blasting conditions, whereas low-velocity products are normally adequate for the less demanding requirements typical of most blasting jobs. Detonation velocity, particularly in modern dry blasting agents and slurries, may vary considerably depending on field conditions. Detonation velocity can often be increased by the following (5):

1. Using a larger charge diameter (see fig. 13, after Ash).
2. Increasing density (although excessively high densities in blasting agents may seriously reduce sensitivity).
3. Decreasing particle size (pneumatic injection of AN-FO in small diameter boreholes accomplishes this).
4. Providing good confinement in the borehole.
5. Providing a high coupling ratio (coupling ratio is the percentage of the borehole diameter filled with explosive).
6. Using a larger initiator or primer (this will increase the velocity near the primer but will not alter the steady state velocity).

There is a difference of opinion among experts as to how important detonation velocity is in the fragmentation process. It probably is of some benefit in propagating the initial cracks in hard, massive rock. In the softer, prefractured rocks typical of most operations, it is of little importance.

### DENSITY

Density is normally expressed in terms of specific gravity, which is the ratio of the density of the explosive to that of water.

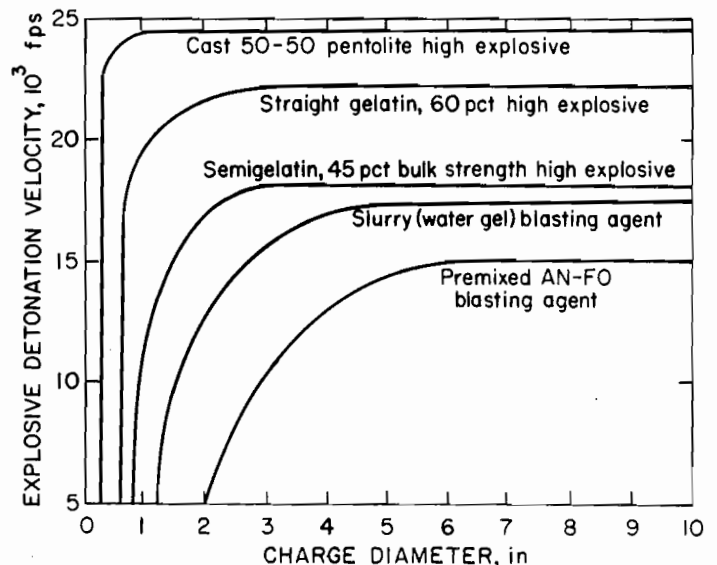

Figure 13.—Effect of charge diameter on detonation velocity.

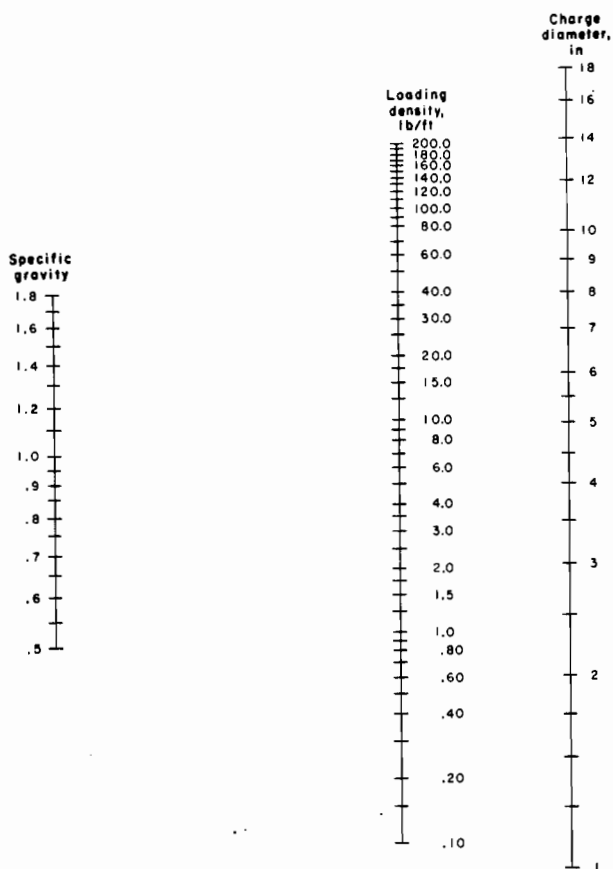

Figure 14.—Nomograph for finding loading density.

A useful expression of density is loading density, which is the weight of explosive per unit length of charge at a specified diameter, commonly expressed in pounds per foot. Figure 14 shows a nomograph for finding loading density. Cartridge count (number of 1¼- by 8-in cartridges per 50-lb box) is useful when dealing with cartridge high explosives and is approximately equal to 141 divided by the specific gravity. The specific gravity of commercial products ranges from 0.5 to 1.7.

The density of an explosive determines the weight that can be loaded into a given column of borehole. Where drilling is expensive, a higher cost, dense product is frequently justified. The energy per unit volume of explosive is actually a more important consideration, although it is not a commonly reported explosive property.

**WATER RESISTANCE**

Water resistance is the ability of an explosive product to withstand exposure to water without losing sensitivity or efficiency. Gelled products such as gelatin dynamites and water gels have good water resistance. Nongelatinized high explosives have poor-to-good water resistance. Ammonium nitrate prills have no water resistance and should not be used in the water-filled portions of a borehole. The emission of brown nitrogen oxide fumes from a blast often indicates inefficient detonation frequently caused by water deterioration, and signifies the need for a more water-resistant explosive or external protection from water in the form of a plastic sleeve or a waterproof cartridge.

**FUME CLASS**

Fume class is a measure of the amount of toxic gases, primarily carbon monoxide and oxides of nitrogen, produced by the detonation of an explosive. Most commercial blasting products are oxygen balanced both to minimize fumes and to optimize energy release per unit cost of ingredients. Fumes are an important consideration in tunnels, shafts, and other confined spaces. Certain blasting conditions may produce toxic fumes even with oxygen-balanced explosives. Insufficient charge diameter, inadequate priming or initiation, water deterioration, removal of wrappers, or the use of plastic borehole liners all increase the likelihood of generating toxic gases. Table 2 shows fume classes adopted by the Institute of Makers of Explosives (7). MSHA standards limit the volume of poisonous gases produced by a permissible explosive to 2.5 cu ft/lb of explosive.

Table 2. - Fume classes designated by the Institute of Makers of Explosives

(Bichel gage method)

Fume class	Cubic foot of poisonous gases per 200 g of explosive
1.....	0.16
2.....	0.16- .33
3.....	.33- .67

### DETONATION PRESSURE

The detonation pressure of an explosive is primarily a function of the detonation velocity squared times the density. It is the head-on pressure of the detonation wave propagating through the explosive column, measured at the C-J plane (fig. 2). Although the relationship of detonation velocity and density to detonation pressure is somewhat complex, and depends on the ingredients of an explosive, the following approximation is one of several that can be made (4):

$$P = 4.18 \times 10^{-7} DC^2 / (1 + 0.8 D),$$

where P = detonation pressure, in kilobars, (1 kb = 14,504 psi),  
 D = specific gravity,  
 and C = detonation velocity, in feet per second.

The nomograph in figure 15, based on this formula, can be used to approximate the detonation pressure of an explosive

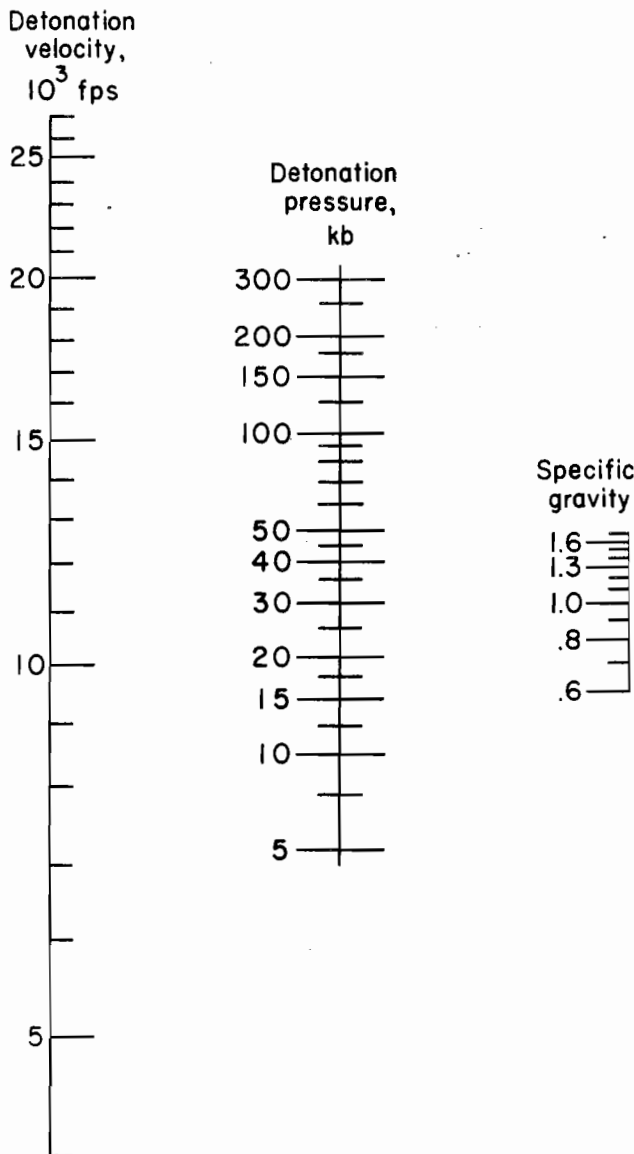

Figure 15.—Nomograph for finding detonation pressure.

when the detonation velocity and specific gravity are known. Some authorities feel that a high detonation pressure resulting in a strong shock wave is of major importance in breaking very dense, competent rock. Others, including Swedish experts (8) feel that it is of little or no importance. As a general recommendation, in hard, massive rock, if the explosive being used is not giving adequate breakage, a higher velocity explosive (hence, a higher detonation pressure explosive) may alleviate the problem. Detonation pressures for commercial products range from about 5 to over 150 kb.

### BOREHOLE PRESSURE

Borehole pressure, sometimes called explosion pressure, is the pressure exerted on the borehole walls by the expanding gases of detonation after the chemical reaction has been completed. Borehole pressure is a function of confinement and the quantity and temperature of the gases of detonation. Borehole pressure is generally considered to play the dominant role in breaking most rocks and in displacing all types of rocks encountered in blasting. This accounts for the success of AN-FO and aluminized products which yield low detonation pressures but relatively high borehole pressures. The 100 pct coupling obtained with these products also contributes to their success. Borehole pressures for commercial products range from less than 10 to 60 kb or more. Borehole pressures are calculated from hydrodynamic computer codes or approximated from underwater test results, since borehole pressure cannot be measured directly. Many AN-FO mixtures have borehole pressures larger than their detonation pressures. In most high explosives the detonation pressure is the greater.

A Swedish formula (8) for comparing the relative rock-breaking capability of explosives is

$$S = 1/6 (V_x/V_o) + 5/6 (Q_x/Q_o),$$

where S is the strength of the explosive, V is the reaction product gas volume, Q is the heat energy, the subscript x denotes the explosive being rated, and the subscript o denotes a standard explosive. This corresponds closely to the borehole pressure of an explosive. Although the complexity of the fragmentation process precludes the use of a single property for rating explosives, more and more explosives engineers are relying on borehole pressure as the single most important descriptor in evaluating an explosive's rock-breaking capability.

### SENSITIVITY AND SENSITIVENESS

These are two closely related properties that have become increasingly important with the advent of dry blasting agents and slurries, which are less sensitive than dynamites. Sensitivity is defined as an explosive's susceptibility to initiation. Sensitivity to a No. 8 test blasting cap, under certain test conditions, means that a product is classified as an explosive. Lack of cap sensitivity results in a classification as a blasting agent. Sensitivity among different types of blasting agents varies considerably and is dependent upon ingredients, particle size, density, charge diameter, confinement, the presence of water, and often, particularly with slurries, temperature (2). Manufacturers often specify a minimum recommended primer for their products, based on field data. In general, products that require larger primers are less susceptible to accidental initiation and are safer to handle.

Sensitiveness is the capability of an explosive to propagate

a detonation once it has been initiated. Extremely sensitive explosives, under some conditions, may propagate from hole to hole. An insensitive explosive may fail to propagate throughout its charge length if its diameter is too small. Sensitiveness is

closely related to critical diameter, which is the smallest diameter at which an explosive will propagate a stable detonation. Manufacturers' technical data sheets give recommended minimum diameters for individual explosives.

## EXPLOSIVE SELECTION CRITERIA

Proper selection of the explosive is an important part of blast design needed to assure a successful blasting program (6). Explosive selection is dictated by economic considerations and field conditions. The blaster should select a product that will give the lowest cost per unit of rock broken, while assuring that fragmentation and displacement of the rock are adequate for the job at hand. Factors which should be taken into consideration in the selection of an explosive include explosive cost, charge diameter, cost of drilling, fragmentation difficulties, water conditions, adequacy of ventilation, atmospheric temperature, propagating ground, storage considerations, sensitivity considerations, and explosive atmospheres.

### EXPLOSIVE COST

No other explosive product can compete with AN-FO on the basis of cost per unit of energy. Both of the ingredients, ammonium nitrate and fuel oil, are relatively inexpensive, both

participate fully in the detonation reaction, and the manufacturing process consists of simply mixing a solid and a liquid ingredient (fig. 16). The safety and ease of storage, handling, and bulk loading add to the attractive economics of AN-FO. It is because of these economics that AN-FO now accounts for approximately 80 pct, by weight, of all the explosives used in the United States. By the pound, slurry costs range from slightly more than AN-FO to about four times the cost of AN-FO. The cheaper slurries are designed for use in large-diameter blastholes and contain no high-cost, high-energy ingredients. They are relatively low in energy per pound. The more expensive slurries are (1) those designed to be used in small diameters and (2) high-energy products containing large amounts of aluminum or other high-energy ingredients. Dynamite cost ranges from four to six times that of AN-FO, depending largely on the proportion of nitroglycerin or other explosive oil.

Despite its excellent economics, AN-FO is not always the best product for the job, because it has several shortcomings. AN-FO has no water resistance, it has a low specific gravity,



Figure 16.—Field mixing of AN-FO. (Courtesy Hercules Inc.)



and under adverse field conditions it tends to detonate inefficiently. Following are additional factors that should be taken into account when selecting an explosive.

### CHARGE DIAMETER

The dependability and efficiency of AN-FO are sometimes reduced at smaller charge diameters, especially in damp conditions or with inadequate confinement. In diameters under 2 in, AN-FO functions best when pneumatically loaded into a dry blasthole. When using charge diameters smaller than 2 in, many blasters prefer the greater dependability of a cartridge slurry or dynamite despite the higher cost. The cost saving that AN-FO offers can be lost through one bad blast.

At intermediate charge diameters, between 2 and 4 in, the use of dynamite is seldom justified because AN-FO and slurries function quite well at these diameters. Slurries designed for use in intermediate charge diameters are somewhat cheaper than small-diameter slurries and are more economical than dynamite. The performance of AN-FO in a 4-in-diameter blasthole is substantially better than at 2 in. Where practical, bulk loading in intermediate charge diameters offers attractive economics.

In blasthole diameters larger than 4 in, a bulk-loaded AN-FO or slurry should be used unless there is some compelling reason to use a cartridge product. AN-FO's efficiency and dependability increase as the charge diameter increases. Where the use of a slurry is indicated, low-cost varieties function well in large charge diameters.

### COST OF DRILLING

Under normal drilling conditions, the blaster should select the lowest cost explosive that will give adequate, dependable fragmentation. However, when drilling costs increase, typically in hard, dense rock, the cost of explosive and the cost of drilling should be optimized through controlled, in-the-mine experimentation with careful cost analysis. Where drilling is expensive, the blaster will want to increase the energy density of the explosive, even though explosives with high-energy densities tend to be more expensive. Where dynamites are used, gelatin dynamites will give higher energy densities than granular dynamites. The energy density of a slurry depends on its density and the proportion of high-energy ingredients, such as aluminum, used in its formulation. Because of the diverse varieties of slurries on the market, the individual manufacturer should be consulted for a recommendation on a high-energy slurry.

In small-diameter blastholes, the density of AN-FO may be increased by up to 20 pct by high-velocity pneumatic loading. The loading density (weight per foot of borehole) of densified AN-FO cartridges is about the same as that of bulk AN-FO because of the void space between the cartridge and the borehole wall. The energy density of AN-FO can be increased by the addition of finely divided aluminum. The economics of aluminized AN-FO improve where the rock is more difficult to drill and blast.

### FRAGMENTATION DIFFICULTIES

Expensive drilling and fragmentation difficulties frequently go hand in hand because hard, dense rock may cause both. Despite the controversy as to the importance of detonation

velocity in rock fragmentation, there is evidence that a high velocity does help in fragmenting hard, massive rock (10). With cartridge dynamites, the detonation velocity increases as the nitroglycerin content increases, with gelatin dynamites having higher velocities than their granular counterparts. Several varieties of slurry, and particularly emulsions, have high velocities. The individual manufacturer should be consulted for a recommendation on a high-velocity product. In general, emulsions exhibit higher velocities than water gels.

The detonation velocity of AN-FO is highly dependent on its charge diameter and particle size. In diameters of 9 in or greater, AN-FO's detonation velocity will normally exceed 13,000 fps, peaking near 15,000 fps in a 15-in diameter. These velocities compare favorably with velocities of most other explosive products. In smaller diameters the detonation velocity falls off, until at diameters below 2 in the velocity is less than half the 15,000-fps maximum. In these small diameters, the velocity may be increased to nearly 10,000 fps by high velocity pneumatic loading, which pulverizes the AN-FO and gives it a higher loading density. As a cautionary note, pressures higher than 30 psi should never be used with a pressure vessel pneumatic loader. Full line pressures of 90 to 110 psi are satisfactory for ejectors. In many operations with expensive drilling and difficult fragmentation, it may be advantageous for the blaster to compromise and use a dense, high-velocity explosive in the lower position of the borehole and AN-FO as a top load.

### WATER CONDITIONS

AN-FO has no water resistance. It may, however, be used in blastholes containing water if one of two techniques is followed. First, the AN-FO may be packaged in a water-resistant, polyburlap container. To enable the AN-FO cartridge to sink in water, part of the prills are pulverized and the mixture is vibrated to a density of about 1.1 g/cu cm. Of course, if a cartridge is ruptured during the loading process, the AN-FO will quickly become desensitized. In the second technique, the blasthole is dewatered by using a down-the-hole submersible pump (3). A waterproof liner is then placed into the blasthole and AN-FO is loaded inside the liner before the water reenters the hole. Again, the AN-FO will quickly become desensitized if the borehole liner is ruptured. The appearance of orange-brown nitrogen oxide fumes upon detonation is a sign of water deterioration, and an indication that a more water-resistant product or better external protection should be used.

Slurries are gelled and cross-linked to provide a barrier against water intrusion, and as a result, exhibit excellent water resistance. The manufacturer will usually specify the degree of water resistance of a specific product. When dynamites are used in wet holes, gelatinous varieties are preferred. Although some granular dynamites have fair water resistance, the slightly higher cost of gelatins is more than justified by their increased reliability in wet blast holes.

### ADEQUACY OF VENTILATION

Although most explosives are oxygen-balanced to maximize energy and minimize toxic detonation gases, some are inherently "dirty" from the standpoint of fumes. Even with oxygen-balanced products, unfavorable field conditions may increase the generation of toxic fumes, particularly when explosives without water resistance get wet. The use of plastic borehole liners, inadequate charge diameters, removal of a cartridge explosive

from its wrapper, inadequate priming, or an improper explosive ingredient mix may cause excessive fumes.

In areas where efficient evacuation of detonation gases cannot be assured (normally underground), AN-FO should be used only in absolutely dry conditions. Most small-diameter slurries have very good fume qualities. Large-diameter slurries have variable fume qualities. The manufacturer should be consulted for a recommendation where fume control is important. Of the cartridge dynamites, ammonia gelatins and semigelatins have the best fume qualities. High-density ammonia dynamites are rated good, low-density ammonia dynamites are fair, and straight dynamites are poor, as shown in table 1. In permissible blasting, where fumes are a concern, care should be exercised in selecting the explosives because many permissibles have poor fume ratings. Permissibles with good fume ratings are available.

### ATMOSPHERIC TEMPERATURE

Until the development of slurries, atmospheric temperatures were not an important factor in selecting an explosive. For many years, dynamites have employed low-freezing explosive oils which permits their use in the lowest temperatures encountered in the United States. AN-FO and slurries are not seriously affected by low temperatures if priming is adequate. A potential problem exists with slurries that are designed to be cap sensitive. At low temperatures, many of these products may lose their cap sensitivity, although they will still function well if adequately primed. If a slurry is to be used in cold weather the manufacturer should be asked about the temperature limitation on the product.

The effect of temperature is alleviated if explosives are stored in a heated magazine or if they are in the borehole long enough to achieve the ambient borehole temperature. Except in permafrost or in extremely cold weather, borehole temperatures are seldom low enough to render slurries insensitive.

### PROPAGATING GROUND

Propagation is the transfer or movement of a detonation from one point to another. Although propagation normally occurs within an explosive column, it may occur between adjacent blastholes through the ground. In ditch blasting, a very sensitive straight nitroglycerin dynamite is sometime used to purposely accomplish propagation through the ground. This saves the cost of putting a detonator into each blasthole. Propagation ditch blasting works best in soft, water-saturated ground.

In all other types of blasting, propagation between holes is undesirable because it negates the effect of delays. Propagation between holes will result in poor fragmentation, failure of a round to pull properly, and excessive ground vibrations, airblast, and flyrock. In underground blasting, the entire round may fail to pull. The problem is most serious when using small blastholes loaded with dynamite. Small blastholes require small burdens and spacings, increasing the chance of hole-to-hole propagation, particularly when sensitive explosives are used. Water saturated material and blasthole deviation compound the problem. When propagation is suspected, owing to poor fragmentation, violent shots, or high levels of ground vibrations, the use of a less sensitive product usually solves the problem. Straight nitroglycerin dynamite is the most sensitive commercial explosive

available, followed by other granular dynamites, gelatin dynamites, cap-sensitive slurries, and blasting agents, in decreasing order of sensitivity.

A different problem can occur when AN-FO or slurry blasting agents are used at close spacings in soft ground. The shock from an adjacent charge may dead press a blasting agent column and cause it to misfire.

### STORAGE CONSIDERATIONS

Federal requirements for magazine construction are less stringent for blasting agents than for high explosives (13). Magazines for the storage of high explosives must be well ventilated and must be resistant to bullets, fire, weather, and theft; whereas a blasting agent magazine need only be theft resistant. Although this is not an overriding reason for selecting a blasting agent rather than an explosive, it is an additional point in favor of blasting agents.

Some activities such as powerline installation and light construction require the periodic use of very small amounts of explosives. In this type of work the operator can advantageously use two-component explosives. Two-component explosives are sold as separate ingredients, neither of which is explosive. The two components are mixed at the jobsite as needed, and the mixture is considered a high explosive. Persons who mix two-component explosives are often required to have a manufacturer's license.

Federal regulations do not require ingredients of two-component explosives to be stored in magazines nor is there a minimum distance requirement for separation of the ingredients from each other or from explosive products. Even though there is no Federal regulation requiring magazine storage, two-component explosives should be protected from theft. Two-component explosives stored under the jurisdiction of the U.S. Forest Service must be stored in magazines.

The use of two-component explosives eliminates the need for frequent trips to a magazine. However, when large amounts of explosives are used, the higher cost and the time-consuming process of explosive mixing begin to outweigh the savings in traveltime.

### SENSITIVITY CONSIDERATIONS

Sensitivity considerations address questions of the safety and the dependability of an explosive. More sensitive explosives such as dynamites are somewhat more vulnerable to accidental initiation by impact or spark than blasting agents. Slurries and nitrostarch-based explosives are generally less sensitive to impact than nitroglycerin-based dynamites. However, more sensitive explosives, all conditions being equal, are less likely to misfire in the blasthole. For instance, upon accidental impact from a drill bit, a blasting agent is less likely to detonate than a dynamite. This does not mean that the blasting agent will not detonate when accidentally impacted. Conversely, under adverse situations such as charge separation in the blasthole, very small charge diameters, or low temperatures, dynamites are less likely to misfire than blasting agents. This tradeoff must be considered primarily when selecting an explosive for small-diameter work. Other selection criteria usually dictate the use of blasting agents when the blasthole diameter is large.

It can be concluded from 1981 explosive consumption figures (12) and field observations that most of the dynamite still used in this country is used in construction, small quarries, and

underground mines, where many operators consider a more sensitive explosive beneficial in their small-diameter blasting. When safely handled and properly loaded, dynamites, dry blasting agents, and slurries all have a place in small-diameter blasting.

### EXPLOSIVE ATMOSPHERES

Blasting in a gassy atmosphere can be catastrophic if the atmosphere is ignited by the flame from the explosive. All underground coal mines are classified as gassy; some metal-nonmetal mines may contain methane or other explosive gases; and many construction projects encounter methane. Where gassy conditions are suspected, MSHA or OSHA should be consulted for guidance.

Permissible explosives (14) offer protection against gas explosions. Most permissible explosives are relatively weak explosives, and will not do an adequate job in most rock, although some relatively powerful permissible gelatins, emulsions, and slurries are available.

All underground coal mines are classified as gassy by MSHA, and permissible explosives are the only type of explosives that can be used in these mines without a variance from MSHA. Salt, limestone, uranium, potash, copper, trona, and oil shale mines may contain methane or other explosive gases and may be classified gassy on an individual basis by MSHA. In these gassy metal-nonmetal mines, MSHA may permit the use of nonpermissible products such as AN-FO, detonating cord, and certain other high explosives and blasting agents. These mines are required to operate under modified permissible rules developed by MSHA on a mine-by-mine basis.

### REFERENCES

1. Cook, M. A. Explosives—A Survey of Technical Advances. *Ind. and Eng. Chem.*, v. 60, No. 7, July 1968, pp. 44-55.
2. Damon, G. H., C. M. Mason, N. E. Hanna, and D. R. Forshey. Safety Recommendations for Ammonium Nitrate-Based Blasting Agents. BuMines IC 8746, 1977, 31 pp.
3. Dannenberg, J. Blasthole Dewatering Cuts Costs. *Rock Products*, v. 76, No. 12, December 1973, pp. 66-68.
4. Dick, R. A. Factors in Selecting and Applying Commercial Explosives and Blasting Agents. BuMines IC 8405, 1968, 30 pp.
5. ———. The Impact of Blasting Agents and Slurries on Explosives Technology. BuMines IC 8560, 1972, 44 pp.
6. Drury, F., and D. G. Westmaas. Considerations Affecting the Selection and Use of Modern Chemical Explosives. Proc. 4th Conf. on Explosives and Blasting Technique, New Orleans, LA, Feb. 1-3, 1978. Society of Explosives Engineers, Montville, OH, pp. 128-153.
7. E. I. du Pont de Nemours & Co., Inc. (Wilmington, DE). Blaster's Handbook. 16th ed., 1978, 494 pp.
8. Johansson, C. H., and U. Langefors. Methods of Physical Characterization of Explosives. Proc. 36th Internat. Cong. of Ind. Chem., Brussels, v. 3, 1966, p. 610.; available for consultation at Bureau of Mines Twin Cities Research Center, Minneapolis, MN.
9. Monsanto Co. (St. Louis, MO). Monsanto Blasting Products AN-FO Manual. Its Explosive Properties and Field Performance Characteristics. September 1972, 37 pp.
10. Porter, D. D. Use of Fragmentation To Evaluate Explosives for Blasting. *Min. Cong. J.*, v. 60, No. 1, January 1974, pp. 41-43.
11. Robinson, R. V. Water Gel Explosives—Three Generations. *Canadian Min. and Met. Bull.*, v. 62, No. 692, December 1969, pp. 1317-1325.
12. U.S. Bureau of Mines. Apparent Consumption of Industrial Explosives and Blasting Agents in the United States, 1981. Mineral Industry Survey, June 23, 1982, 12 pp.
13. U.S. Department of the Treasury; Bureau of Alcohol, Tobacco, and Firearms. Explosive Materials Regulations. *Federal Register*, v. 42, Nov. 149, Aug. 3, 1977, pp. 39316-39327; *Federal Register*, v. 45, No. 224, Nov. 18, 1980, pp. 76191-76209.
14. U.S. Mine Enforcement and Safety Administration. Active List of Permissible Explosives and Blasting Devices Approved Before Dec. 31, 1975. MESA Inf. Rep. 1046, 1976, 10 pp.

## Chapter 2.—INITIATION AND PRIMING

### INITIATION SYSTEMS

A considerable amount of energy is required to initiate a high explosive such as a dynamite or cap-sensitive slurry. In blasting, high explosives are initiated by a detonator, which is a capsule containing a series of relatively sensitive explosives that can be readily initiated by an outside energy source. Blasting agents, which are the most common products used as the main column charge in the blasthole, are even less sensitive to initiation than high explosives. To assure dependable initiation of these products, the initiator is usually placed into a container of high explosives, which in turn is placed into the column of blasting agent.

An initiation system consists of three basic parts.

1. An initial energy source.
2. An energy distribution network that conveys energy into the individual blastholes.
3. An in-the-hole component that uses energy from the distribution network to initiate a cap-sensitive explosive.

The initial energy source may be electrical, such as a generator or condenser-discharge blasting machine or a powerline used to energize an electric blasting cap, or a heat source such as a spark generator or a match. The energy conveyed to and into the individual blastholes may be electricity, a burning fuse, a high-energy explosive detonation, or a low-energy dust or gas detonation. Figure 17 shows a typical detonator or "business end" of the initiation system. This detonator, when inserted into a cap-sensitive explosive and activated, will initiate the detonation of the explosive column. Commercial detonators vary in strength from No. 6 to No. 12. Although No. 6 and No. 8 detonators are the most common, there is a trend toward higher strength detonators, particularly when blasting with cap-sensitive products which are less sensitive than dynamites.

The primer is the unit of cap-sensitive explosive containing the detonator. Where the main blasthole charge is high explosive, the detonator may be inserted into the column at any point. However, most of the products used for blasting today (blasting agents) are insensitive to a No. 8 detonator. To detonate these products, the detonator must be inserted into a unit of cap-sensitive explosive, which in turn is inserted into the blasting agent column at the desired point of initiation.

The discussions of the various initiation and priming systems will concentrate primarily on common practice. With each system there are optional techniques and "tricks of the trade" that increase system versatility. It is a good idea to confer with the manufacturer before finalizing your initiation and priming program, so you fully understand how to best use a specific system.

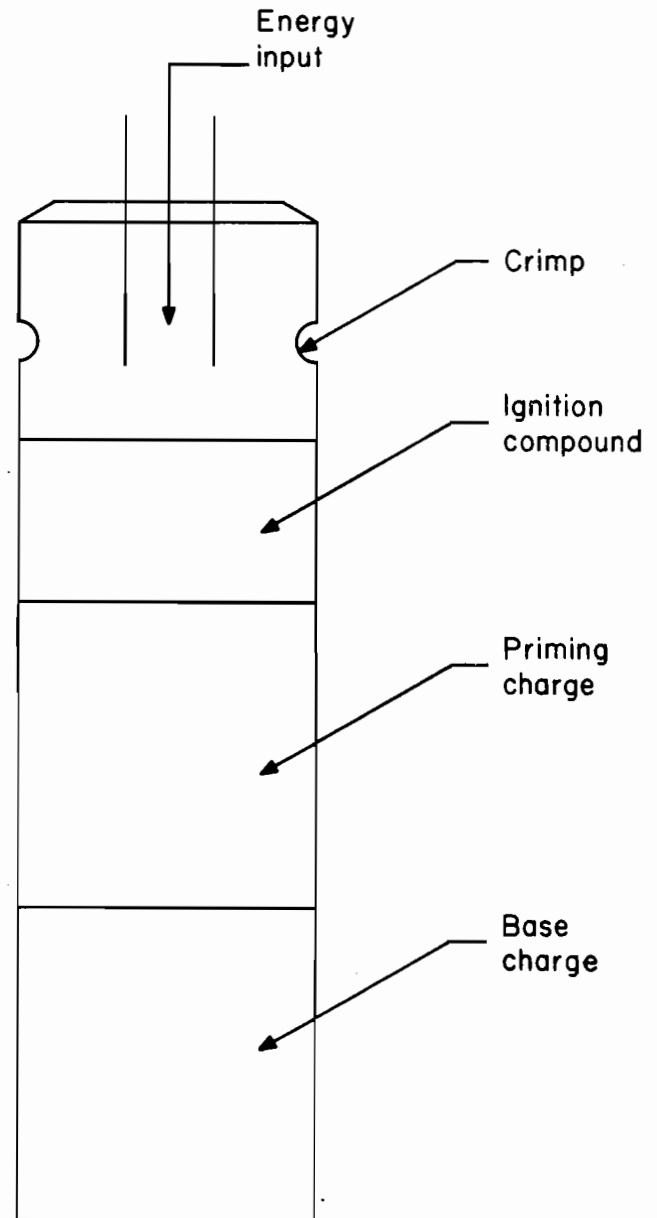

Figure 17.—Instantaneous detonator.

### DELAY SERIES

Figure 17 shows an instantaneous detonator. In this type of detonator, the base charge detonates within a millisecond or two after the external energy enters the detonator. However,

in most types of blasting, time intervals are required between the detonation of various blastholes or even between decks within a blasthole. To accomplish this, a delay element containing

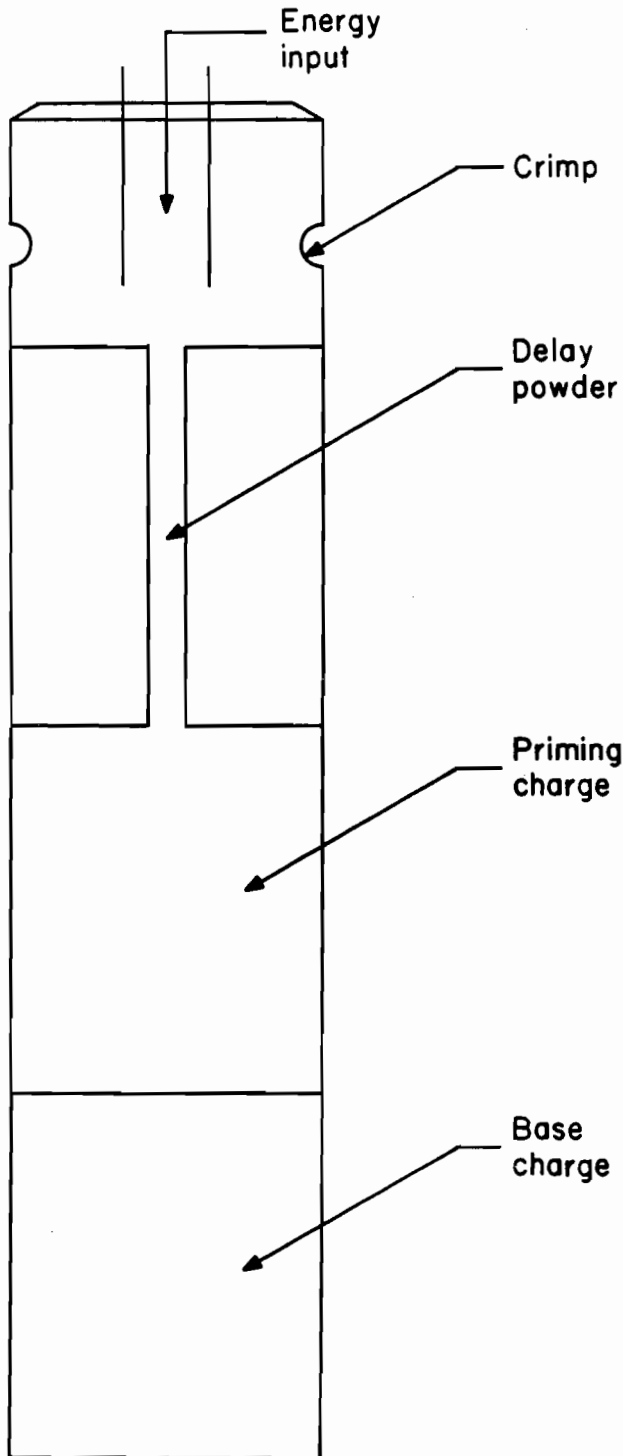

Figure 18.—Delay detonator.

a burning powder is placed immediately before the priming charge in the detonator. Figure 18 shows a delay detonator.

There are three basic delay series; slow or tunnel delays, fast or millisecond delays, and coal mine delays for use in underground coal mines. For all commercial delay detonators, the delay time is determined by the length and burning rate of the delay powder column. As a result, slow delay caps may be quite long in dimension whereas lower period millisecond delays are shorter. Although the timing of delay detonators is sufficiently accurate for most blasting needs, these delays are not precise, as indicated by recent research. Recently, however, manufacturers' tolerances for some delay caps have been tightened. It is important to use the manufacturer's recommended current level to initiate electric blasting caps. Current levels above or below the recommended firing level can further increase the scatter in delay cap firing times. Extremely high currents can speed up delay firing times. Near the minimum firing current, delays can become extremely erratic.

Slow delays are useful underground under tight shooting conditions where it is essential that the burden on one hole moves before a subsequent hole fires. This situation may occur in tunnels, shafts, underground metal-nonmetal mines, and in trenching. Slow delays are available with all initiation systems except surface detonating cord and delay cast primers. Delay intervals are typically 0.5 to 1 sec.

Millisecond delays are the most commonly used delays and are useful wherever the tight conditions previously mentioned are not present. Millisecond delays provide improved fragmentation, controlled throw, and reduced ground vibration and airblast, as compared with simultaneous firing. They are available with all initiation systems. In millisecond detonators, delay intervals are 25 to 50 ms in the lower periods and are longer in the higher periods. In detonating cord delay connectors, the delay may be as short as 5 ms.

Coal mine delays are a special series of millisecond delays. Since only electric initiation systems are permissible in underground coal mines, coal mine delays are available only with electric initiators. Delay intervals are from 50 to 100 ms, with instantaneous caps being prohibited. Coal mine delay caps always utilize copper alloy shells and iron leg wires. Iron leg wires are also available optionally with ordinary electric detonators and are used primarily to facilitate magnetic removal of the wires from the muck pile, such as in trona and salt mines.

## ELECTRIC INITIATION

Electric initiation has been used for many years in both surface and underground blasting. An electric blasting cap (fig. 19) consists of two insulated leg wires that pass through a

waterproof seal and into a metal capsule containing a series of explosive powders (fig. 20). Leg wires of various lengths are available to accommodate various borehole depths. Inside the

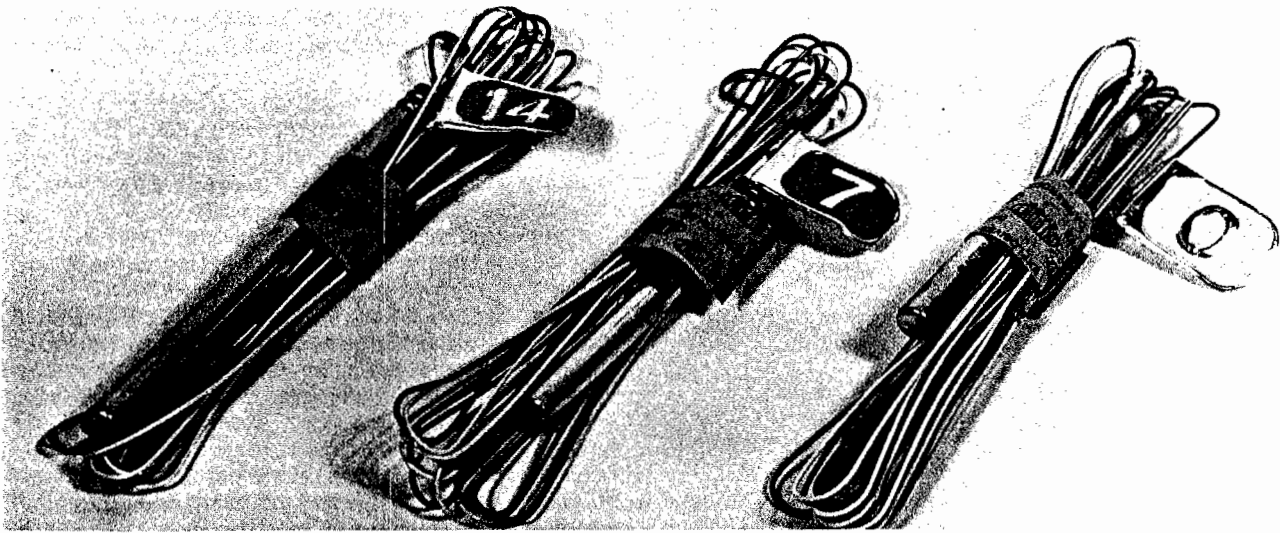

Figure 19.—Electric blasting caps. (Courtesy Du Pont Co.)

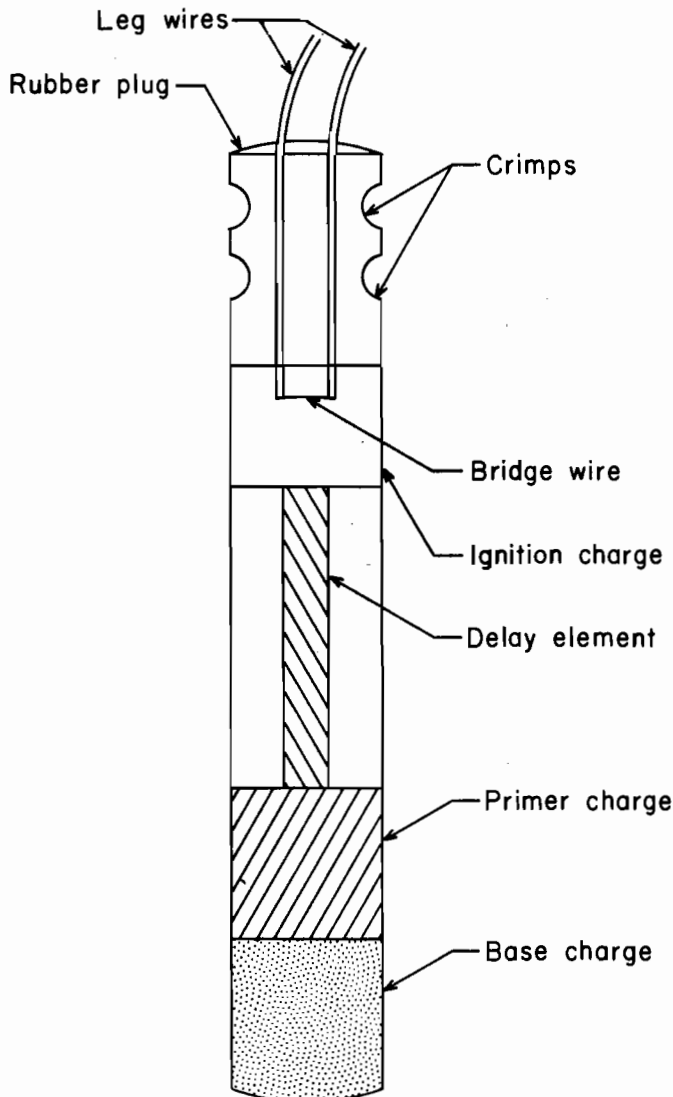

Figure 20.—Delay electric blasting cap.

capsule the two leg wires are connected by a fine filament bridge wire embedded in a highly heat-sensitive explosive. Upon application of electric current the bridge wire heats sufficiently to initiate the ignition mixture, which in turn initiates a series of less sensitive, more powerful explosives. Detonators are available in strengths ranging from about No. 6 to No. 12, with No. 6 and No. 8 being most common. Trends recently are toward higher strength detonators.

Most electric blasting caps have copper leg wires. Iron leg wires are available for use where magnetic separation is used to remove the leg wires at the preparation plant. Atlas Powder<sup>1</sup> Co. has prepared an excellent handbook that describes electric blasting procedures in detail.<sup>(2)</sup>

The Saf-T-Det and Magnadet electric blasting caps are two recent developments. The Saf-T-Det resembles a standard electric blasting cap but has no base charge. A length of 100-gr or less detonating cord is inserted into a well to act as a base charge just before the primer is made up. The device is similar to an electric blasting cap in regard to required firing currents and extraneous electricity hazards. The Saf-T-Det is manufactured in India and is not available in the United States at this time.

The Magnadet is also similar to a standard electric blasting cap, except that the end of each cap lead contains a plastic-covered ferrite toroidal ring. The system is hooked up by passing a single wire through each ring. A special blasting machine is used to fire these detonators. The manufacturer, ICI of Scotland, claims ease of hookup and protection against extraneous electricity as advantages of this system.

## TYPES OF CIRCUITS

In order to fire electric blasting caps, the caps must be connected into circuits and energized by a power source. There are three types of electric blasting circuits (fig. 21). In order of preference they are series, parallel series, and parallel.

<sup>1</sup>Reference to specific trade names or manufacturers does not imply endorsement by the Bureau of Mines.

<sup>2</sup>Italicized numbers in parentheses refer to items in the list of references at the end of this chapter.

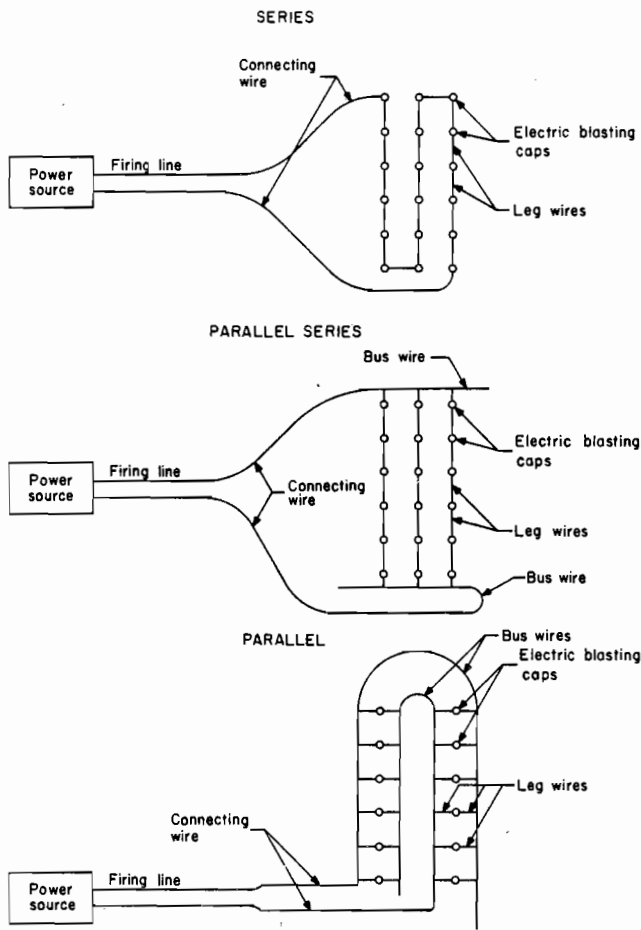

Figure 21.—Types of electric blasting circuits.

In series circuits all the caps are connected consecutively so that the current from the power source has only one path to follow. The series circuit is recommended because of its simplicity. Also, all the caps receive the same amount of current.

Figure 22 shows recommended wire splices for blasting circuits. To splice two small wires, the wires are looped and twisted together. To connect a small wire to a large wire, the small wire is wrapped around the large wire.

The electrical resistance of a series of caps is equal to the sum of the resistances of the individual caps. For most blasting machines, it is recommended that the number of caps in a single series be limited to 40 to 50, depending on the leg wire

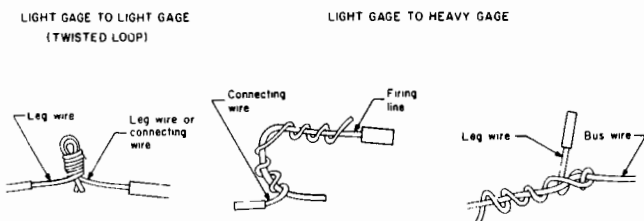

Figure 22.—Recommended wire splices.

length. Longer leg wires require smaller series. The limit for most small twist-type blasting machines is 10 caps with 30-ft leg wires.

Many blasters minimize excess wire between holes to keep the blast site from being cluttered. The ends of the cap series are extended to a point of safety by connecting wire, which is usually 20 gage, but should be heavier where circuit resistance is a problem or when using parallel circuits. This connecting wire is considered expendable and should be used only once. The connecting wire is in turn connected to the firing line, which in turn is connected to the power source.

The firing line contains two single conducting wires of 12 gage or heavier, and is reused from shot to shot. It may be on a reel mechanism for portability, or may be installed along the wall of a tunnel in an underground operation. Installed firing lines should not be grounded, should be made of copper rather than aluminum, and should have a 15-ft lightning gap near the power source to guard against premature blasts. The firing line should be inspected frequently and replaced when necessary.

When the number of caps in a round exceeds 40 to 50, the parallel series circuit is recommended. In a parallel series circuit, the caps are divided into a number of individual series. Each series should contain the same number of caps or the same resistance to assure even current distribution. The leg wires of the caps in each series are connected consecutively. Next, two bus wires, as shown in figure 21, are placed in such a position that each end of each series can be connected as shown in the figure. The bus wire is usually about 14 gage or heavier and may be either bare or insulated. Where bare wires are used, care must be exercised to prevent excessive current leakage to the ground. It is recommended that insulated bus wires be used and that the insulation be cut away at point of connection with the blasting cap series. To assure equal current distribution to each series, one bus wire should be reversed as shown in figure 21. With parallel series circuits, 14 gage or heavier gage connecting wire is used to reduce the total circuit resistance.

The third type of blasting circuit is the straight parallel circuit. The straight parallel circuit is less desirable to use than the series or series parallel circuits for two reasons. First, its nature is such that it cannot be checked. Broken leg wires or faulty connections cannot be detected once the circuit has been hooked up. Second, because the available current is divided by the number of caps in the circuit, powerline firing must often be used to provide adequate current for large parallel circuits. The problems associated with powerline firing will be discussed later.

Parallel circuits are not appropriate for surface blasting but they are used to some extent for tunnel blasting. Parallel circuits are similar to parallel series except that instead of each end of a series circuit being connected to alternate bus wires, each leg wire of each cap is connected directly to the bus wires, as shown in figure 21. In underground blasts using parallel circuits, bare bus wire is usually strung on wooden pegs driven into the face to avoid grounding. As with parallel series circuits, the bus wires are reversed as shown in figure 21.

In a parallel circuit the lead wire (firing line) represents the largest resistance in the circuit. Keeping the lead wire as short as possible, consistent with safety, is the key to firing large numbers of caps with parallel circuits. Doubling the length of the lead wire reduces the number of caps that can be fired by almost half. Heavy (12 to 14 gage) bus wires are used to reduce the resistance. A 14-gage connecting wire, rather than a lighter gage, is recommended to reduce the circuit resistance.

## CIRCUIT CALCULATIONS

Only the very basics of circuit calculations are covered here. For more detail on circuit calculations or other of the many intricacies of electrical blasting the reader should refer to a detailed electric blasting handbook such as reference 2. Figure 23 shows the resistance calculations for cap circuits for series, parallel series, and straight parallel circuits.

The resistance of a series circuit is the easiest to calculate. First, the resistance of a single cap, as specified by the manufacturer, is multiplied by the number of caps to determine the resistance of the cap circuit. To this is added the resistance of the connecting wire and that of the firing line to determine the resistance of the total circuit. Since the firing line contains two wires, there will be 2 ft of wire for every foot of firing line. Where bus wire is used (parallel or parallel series circuits) the resistance of one-half of the length of the bus wire is added to find the total circuit resistance. When firing from a powerline, the voltage of the line divided by the resistance of the circuit will give the current flow. In a single series circuit, all of this current flows through each cap. The minimum recommended firing current per cap is 1.5 amp dc or 2.0 amp ac. The current output of condenser (capacitor) discharge blasting machines may vary with the circuit resistance, but not linearly. Manufacturer's specifications must be consulted to determine the amperage of a specific machine across a given resistance. For a generator blasting machine, the manufacturer rates the machine in terms of the number of caps it can fire.

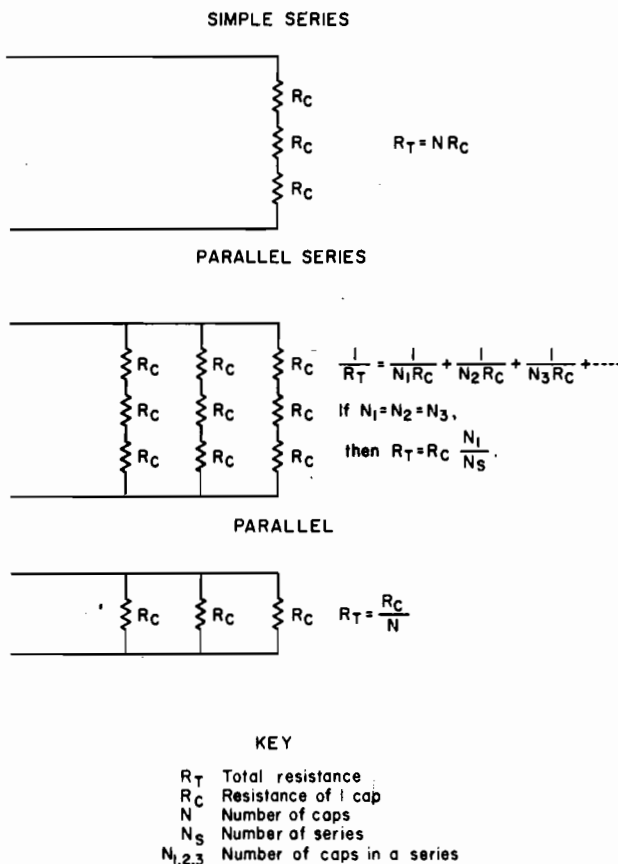

Figure 23.—Calculation of cap circuit resistance.

The resistance calculation for a parallel series circuit is as follows. First the resistance of each cap series is calculated as previously described. Remember, in a good parallel series circuit the resistance of each series should be equal. The resistance of a single series is then divided by the number of series to find the resistance of the cap circuit. To this are added the resistance of half the length of bus wire used, the resistance of the connecting wire, and the resistance of the firing line, to obtain the total circuit resistance. The locations of the bus wire, connecting wire, and firing line are shown in figure 21. The current flow is determined either by dividing the powerline voltage by the circuit resistance or in the case of a condenser discharge machine, by checking the manufacturer's specifications. The current flow is divided by the number of series to determine the current flow through each series.

For straight parallel circuits, the resistance of the cap circuit is equal to the resistance of a single cap divided by the number of caps. As can readily be seen, this is usually a very small value. For 20 short leg wire caps, the resistance is less than 0.1 ohm. The resistance of the connecting wire, the firing line, and one-half the bus wire are added to find the total resistance. The current flow is determined in the same manner as with series and parallel series circuits. The current flow is divided by the number of caps to determine the current flow through each cap.

## POWER SOURCES

Electric blasting circuits can be energized by generator-type blasting machines, condenser-discharge blasting machines, and powerlines. Storage and dry cell batteries are definitely not recommended for blasting because they cannot be depended on for a consistent output.

Generator blasting machines may be of the rack-bar (push down) or the key-twist type. The capacity of rack-bar machines ranges from 30 to 50 caps in a single series, while key-twist machines will normally initiate 10 or 20 caps in a single series. The actual current put out by these machines depends on the condition of the machine and the effort exerted by the shot-firer. When using a rack-bar machine, the terminals should be on the opposite side of the machine from the operator. Both the rack-bar and twist machines should be operated vigorously to the end of the stroke because the current flows only at the end of the stroke. Because the condition of a generator blasting machine deteriorates with time, it is important that the machine be periodically checked with a rheostat designed for that purpose. The directions for testing with a rheostat are contained on the rheostat case or on the rheostat itself. Although the generator machine has been a dependable blasting tool, its limited capacity and variable output have caused it to be replaced, for most applications, by the condenser (capacitor) discharge machine.

As the name implies, the capacitor discharge (CD) machine (fig. 24) employs dry cell batteries to charge a series of capacitors. The energy stored in the capacitor is then discharged into the blasting circuit. CD machines are available in a variety of designs and capacities, with some capable of firing over 1,000 caps in a parallel series circuit.

All CD machines operate in basically the same manner. One button or switch is activated to charge the capacitors and a second button or switch is activated to fire the blast. An indicator light or dial indicates when the capacitor is charged to its rated capacity. Ideally, the overall condition of a CD blasting machine should be checked with an oscilloscope. However, the current output can be checked by using a specially designed setup combining a rheostat and a resistor (2) or by using a



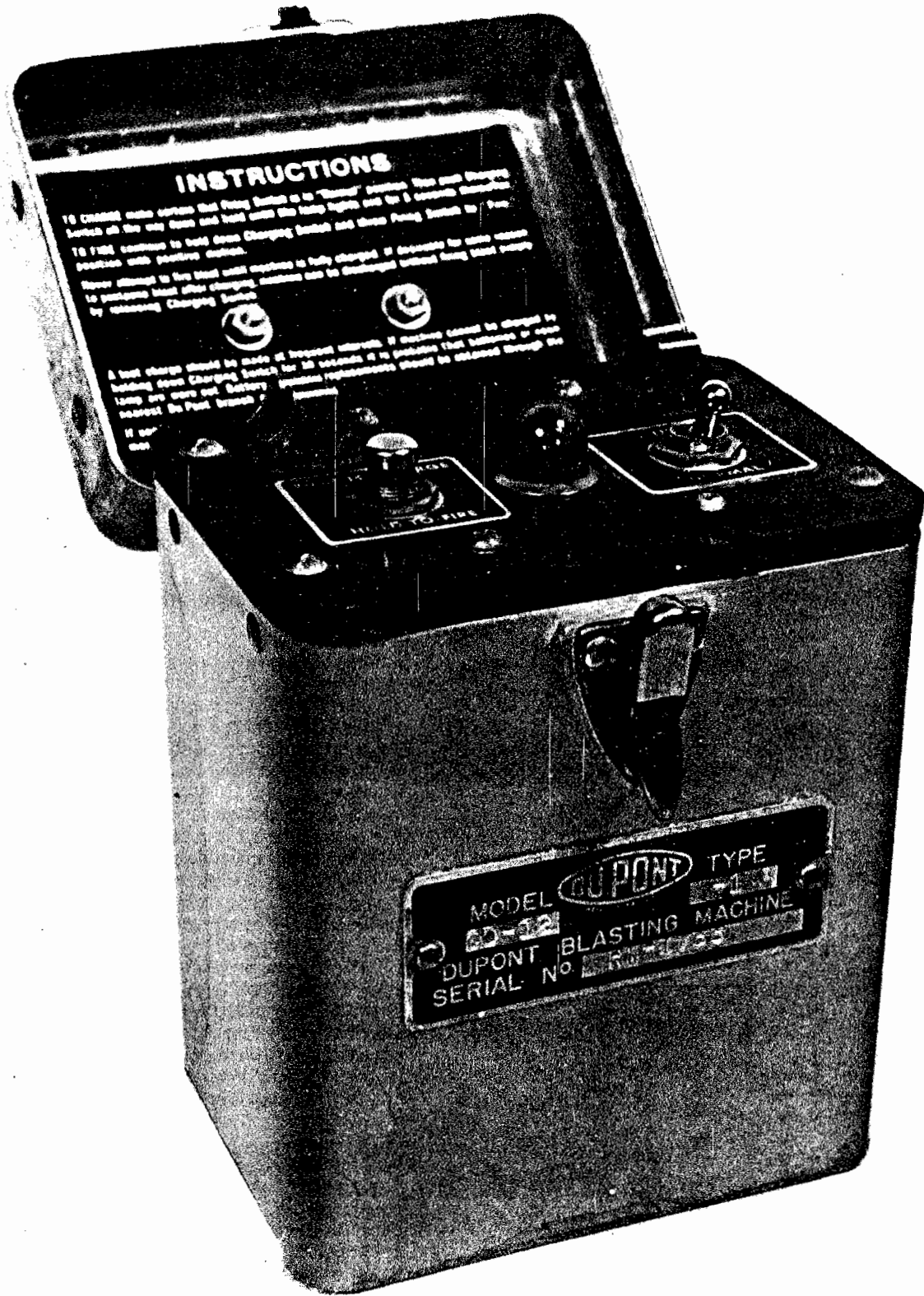

Figure 24.—Capacitor discharge blasting machine. (Courtesy Du Pont Co.)

capacitor discharge checking machine (7). The powder supplier should be consulted as to the availability of machines for checking capacitor discharge machines.

A sequential blasting machine (fig. 25) is a unit containing 10 capacitor discharge machines that will fire up to 10 separate circuits with a preselected time interval between the individual

circuits. When used in conjunction with millisecond delay electric blasting caps, the sequential machine provides a very large number of separate delay intervals (3). This can be useful in improving fragmentation and in controlling ground vibrations and airblast. Because blast pattern design and hookup can be quite complex, the sequential blasting machine should be

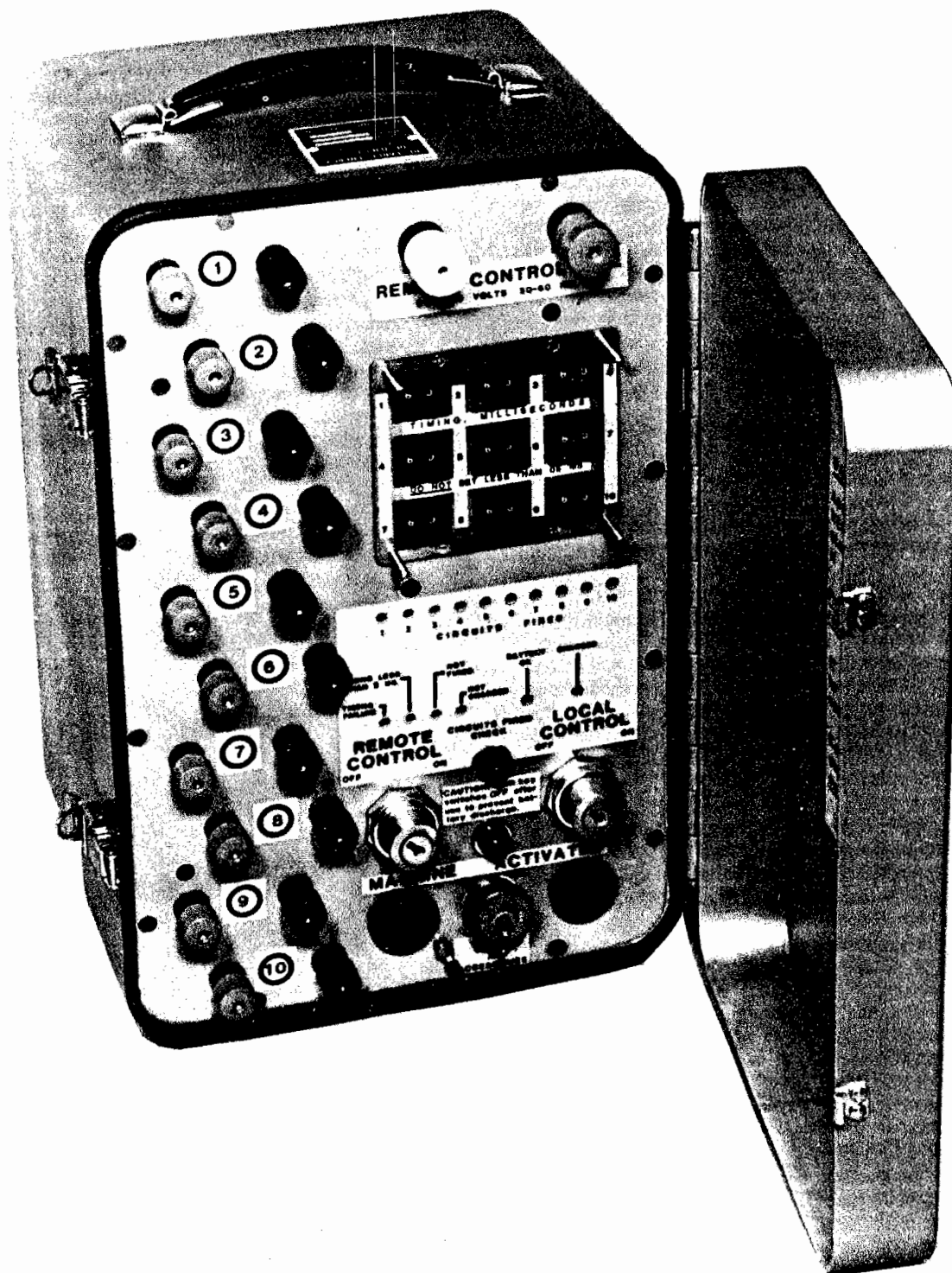

Figure 25.—Sequential blasting machine.

used only by well-trained persons or under the guidance of a consultant or a powder company representative. A poorly planned sequential timing pattern will result in poor fragmentation and excessive overbreak, flyrock, ground vibrations, and noise.

The third alternative for energizing electric blasting circuits is the powerline. Powerline blasting is often done with parallel circuits where the capacity of available blasting machines is inadequate. When firing off a powerline, the line should be dedicated to blasting alone, should contain at least a 15-ft lightning gap, and should be visually checked for damage and for resistance on a regular basis. Powerline shooting should not be done unless precautions are taken to prevent arcing. Arcing can result in erratic timing, a hangfire, or a misfire.

Arcing in a cap results from excessive heat buildup, which is caused by too much current applied for too long a period of time. A current of 10 amp or more continuously applied for a second or more can cause arcing. To guard against arcing the blaster may either use a blasting switch in conjunction with the powerline or add a No. 1 period millisecond delay cap, placed in a quarter stick of explosive, to the circuit and tape the explosive to one of the connecting wires leading to the cap circuit. An even better solution, if possible, is to use a high-output capacitor discharge machine to fire the shot, using a parallel series circuit if necessary.

## CIRCUIT TESTING

It is important to check the resistance of the blasting circuit to make sure that there are no broken wires or short circuits and that the resistance of the circuit is compatible with the capacity of the power source. There are two types of blasting circuit testers; a blasting galvanometer (actually an ohmmeter) shown in figure 26 and a blasting multimeter, shown in figure 27. The blasting galvanometer is used only to check the circuit resistance, whereas a blasting multimeter can be used to check resistance, ac and dc voltage, stray currents, and current leakage (2). Only a meter specifically designed for blasting should be used to check blasting circuits. The output of such meters is limited to 0.05 amp, which will not detonate an electric blasting cap, by the use of a silver chloride battery and/or internal current-limiting circuitry.

Other equipment such as a "throw-away" go-no go device for testing circuits and a continuous ground current monitor is available. The explosive supplier should be consulted to determine what specific electrical blasting accessory equipment is available and what equipment is needed for a given job.

It is generally recommended that each component of the circuit be checked as hookup progresses. After each component is tested, it should be shunted. Each cap should be checked after the hole has been loaded and before stemming. In this way, a new primer can be inserted if a broken leg wire is detected. A total deflection of the circuit tester needle (no resistance) indicates a short circuit. Zero deflection of the needle (infinite resistance) indicates a broken wire. Either condition will prevent a blasting cap, and possibly the whole circuit, from firing.

Before testing the blasting circuit, its resistance should be calculated. After the caps have been connected into a circuit the resistance of the circuit is checked and compared with the calculated value. A zero deflection at this time indicates a broken wire or a missed connection and an excessive deflection indicates a short circuit between two wires.

After the circuit resistance has been checked and compared, the connecting wire is then added and the circuit is checked again. If a parallel series circuit is used, the change in resis-

tance should be checked as each series is added to the bus wire. In a straight parallel circuit, a break in the bus wire can sometimes be detected. However, a broken or a shorted cap wire cannot be detected in a straight parallel circuit because it will not affect the resistance significantly.

A final check of the circuit is made at the shottirer's location after the firing line has been connected. If a problem is found in a completed circuit, the circuit should be broken up into separate parts and checked to isolate the problem. The firing line should be checked for a break or a short after each blast, or at the end of each shift, as a minimum.

To check for a break in the firing line, the two wires at one end of the line are shunted and the other end is checked with a blasting meter. A large deflection indicates that the firing line is not broken; a zero deflection indicates a broken wire. To test for a short, the wires at one end of the lead line are separated and the other end is checked with the meter. A zero deflection should result. If there is a deflection, the lead line has a short circuit. Embarrassing, hazardous, and costly misfires can be avoided through proper use of the blasting galvanometer or blasting multimeter.

Certain conditions such as damaged insulation, damp ground, a conductive ore body, water in a borehole, bare wires touching the ground, or bulk slurry in the borehole may cause current to leak from a charged circuit. Although this is not a common occurrence, you may want to check for it if you are experiencing unexplained misfires. To properly check for current leakage you should check with a consultant or an electric blasting handbook (2). Measures for combating current leakage include using fewer caps per circuit, using heavier gage lead lines and connecting wires, keeping bare wire connections from touching the ground, or using a nonelectric initiation system.



Figure 26.—Blasting galvanometer. (Courtesy Du Pont Co.)



Figure 27.—Blasting multimeter. (Courtesy Du Pont Co.)

## EXTRANEOUS ELECTRICITY

The principal hazard associated with electric blasting systems is lightning. Extraneous electricity in the form of stray currents, static electricity, and radiofrequency energy, and from high-voltage powerlines can also be a hazard. Electric blasting caps should not be used in the presence of stray currents of 0.05 amp or more. Stray currents usually come from heavy equipment or power systems in the area, and are often carried by metal conductors or high-voltage powerlines. Atlas (2) outlines techniques for checking for stray currents. Instruments have recently been developed which continuously monitor ground currents and sound an alarm when an excess current is detected. The supplier should be consulted as to the availability of these units.

Static electricity may be generated by pneumatic loading, particles carried by high winds, particularly in a dry atmosphere, and by rubbing of a person's clothes. Most electric blasting caps are static resistant. When pneumatically loading blasting agents with pressure pots or venturi loaders, a semiconductive loading hose must be used, a plastic borehole liner should not be used, and the loading vessel should be grounded.

Electrical storms are a hazard regardless of the type of initiation system being used. Even underground mines are susceptible to lightning hazards. Upon the approach of an electrical storm, loading operations must cease and all personnel must retreat to a safe location. The powder manufacturer should be consulted on the availability of commercial storm warning devices. Some operators use static on an AM radio as a crude detector of approaching storms. Weather reports are also helpful.

Broadcasting stations, mobile radio transmitters, and radar installations present the hazard of radiofrequency energy. The IME (11) has prepared charts giving transmission specifications and potentially hazardous distances.

High-voltage powerlines present the hazards of capacitive and inductive coupling, stray current, and conduction of lightning. Atlas (2) details precautions to be taken when blasting near high-voltage powerlines. A specific hazard with powerlines is the danger of throwing part of the blasting wire onto the powerline. This shorts the powerline to the ground and has been responsible for several deaths. Care should be exercised in laying out the circuit so that the wires cannot be thrown on a powerline. Other alternatives are to weigh down the wires so they cannot be thrown or attach a charge that cuts the blasting wire.

## ADDITIONAL CONSIDERATIONS

Electric blasting is a safe, dependable system when used properly under the proper conditions. Advantages of the system are its reasonably accurate delays, ease of circuit testing, control of blast initiation time, and lack of airblast or disruptive effect on the explosive charge. In addition to extraneous electricity, one should guard against kinks in the cap leg wires, which can cause broken wires, especially in deep holes. Different brands of caps may vary in electric properties, so only one brand per blast should be used. It is recommended that the blaster carry the key or handle to the power source on his or her person so the shot cannot be inadvertently fired while he or she is checking out the shot.

A device called an exploding bridge wire is available for use where a single cap is used to initiate a nonelectric circuit. This device has the safety advantages of a lack of primary explosive in the cap and a high voltage required for firing. A special firing box is required for the system. The high power required and high cost of the exploding bridge wire device make it unsuitable for use in multicap circuits.

## DETONATING CORD INITIATION

Detonating cord initiation has been used for many years as an alternative to electric blasting where the operator prefers not to have an electric initiator in the blasthole. Detonating cord (fig. 28) consists of a core of high explosive, usually PETN, contained in a waterproof plastic sheath enclosed in a reinforcing covering of various combinations of textile, plastic, and waterproofing. Detonating cord is available with PETN core loadings ranging from 1 to 400 gr/ft.

All cords can be detonated with a blasting cap and have a detonation velocity of approximately 21,000 fps. Detonating cord is adaptable to most surface blasting situations. When used in a wet environment the ends of the cord should be protected from water. PETN will slowly absorb water and as a result will become insensitive to initiation by a blasting cap. Even when wet, however, detonating cord will propagate if initiated on a dry end. Understanding the function of a detonating cord initiation system requires a knowledge of the products available. The Ensign Bickford Co. has published a manual (8) that describes detonating cord products in detail. Technical data sheets are available from Austin Powder Co. and Apache Powder Co.

## DETONATING CORD PRODUCTS

The most common strengths of detonating cord are from 25 to 60 gr/ft. These strengths are used for trunklines, which connect the individual blastholes into pattern, and for downlines, which transmit the energy from the trunkline to the primer cartridge. The lower strength cords are cheaper, but some have less tensile strength and may be somewhat less dependable under harsh field conditions. Some cast primers are not dependably initiated by 25-gr cord or lighter cord. However, under normal conditions, the lighter core loads offer economy and their greater flexibility makes field procedures such as primer preparation and knot tying easier.

Detonating cord strengths of 100 to 200 gr/ft are occasionally used where continuous column initiation of a blasting agent is desired. Cords with 200 to 400 gr of PETN per foot are occasionally used as a substitute for explosive cartridges in very sensitive or small, controlled blasting jobs. Controlled blasting is described in the "Blast Design" chapter.

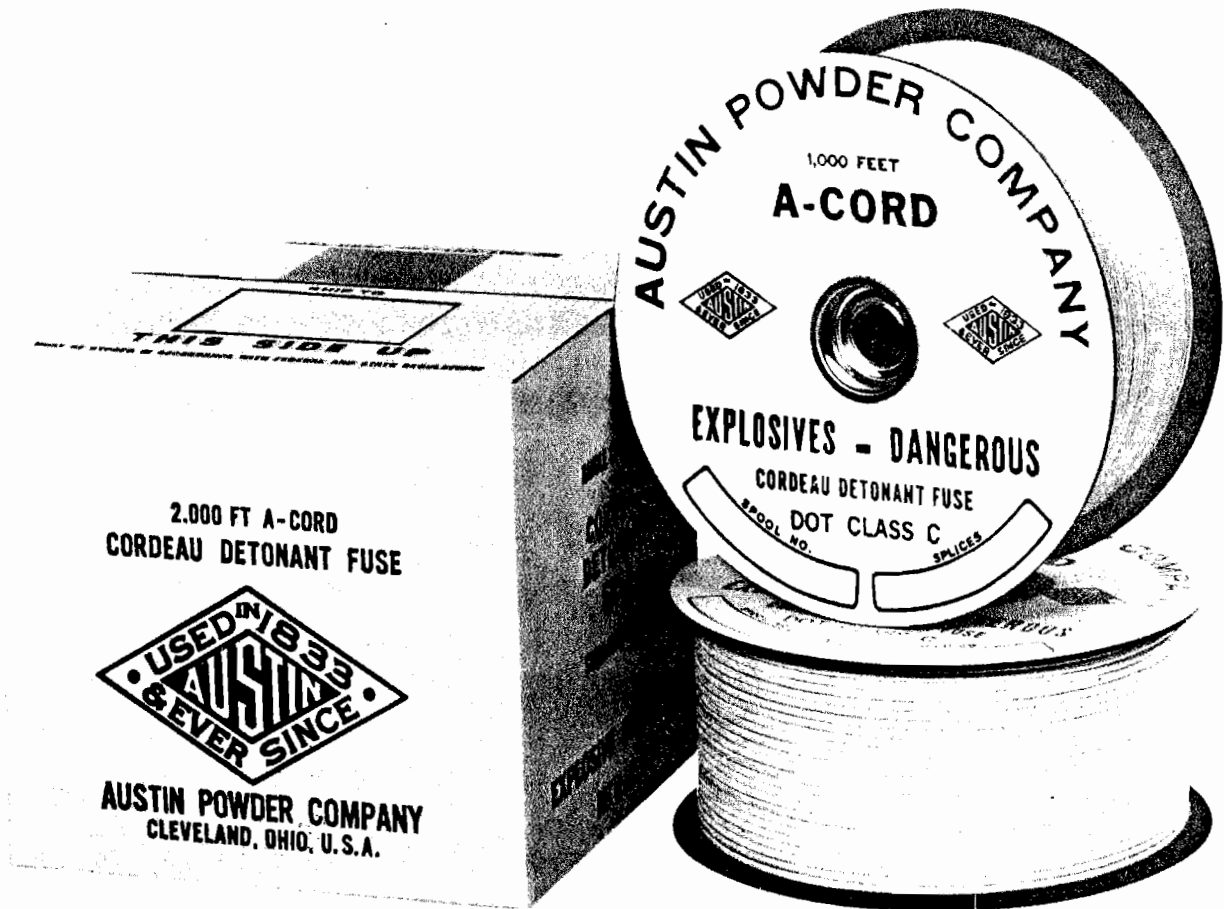

Figure 28.—Detonating cord. (Courtesy Austin Powder Co.)

Detonating cord strengths lower than 25 gr/ft are sometimes used. Fifteen- to twenty-grain products may be used for small-diameter holes, for secondary blasting, and in the Nonel system described later. A 7.5-gr cord is also used in the Nonel system. A 4-gr/ft product is used as part of an assembly called a Primadet. A Primadet consists of a length of 4-gr cord crimped to a standard instantaneous or delay blasting cap. The cap is inserted into the primer and the 4-gr cord serves as a downline. Various cord lengths are available to suit specific borehole depths. These Primadets are primarily used in underground mines, such as salt, where Nonel tubes would be a product contaminant. Du Pont's new Detaline System utilizes a 2.4-gr cord.

Millisecond delay surface connectors are used for delaying detonating cord blasts. To place a delay between two holes, the trunkline between the holes is cut and the ends are joined with a delay connector. One type of delay connector is a plastic assembly containing a delay element (fig. 29). At each end of the element is an opening into which a loop of the severed trunkline can be inserted. A tapered pin is used to lock the trunkline cord into place. A Nonel delay connector has also been developed for detonating cord blasting (fig. 30). This

connector consists of two plastic blocks, each containing a delay initiator, connected by a short length of Nonel tubing. Each end of the severed trunkline is wrapped around the notch in one of the plastic blocks. Both types of delay connector are bidirectional.

### FIELD APPLICATION

After the primer has been lowered to its proper location in the blasthole, the detonating cord is cut from the spool. About 2 or 3 ft of cord should extend from the hole to allow for charge settlement and tying into the trunkline. When the entire shot has been loaded and stemmed, the trunkline is laid out along the path of desired initiation progression. Trunkline-to-trunkline connections are usually made with a square knot. A tight knot, usually a clove hitch, a half hitch, or a double-wrap half hitch, is used to connect the downline to the trunkline (fig. 31). Any excess cord from the downline should be cut off and disposed. If Primadets or other in-hole delay assemblies are used, a plastic connector often serves as the connection to the trunkline. The cord lines should be slack, but not excessively so. If too

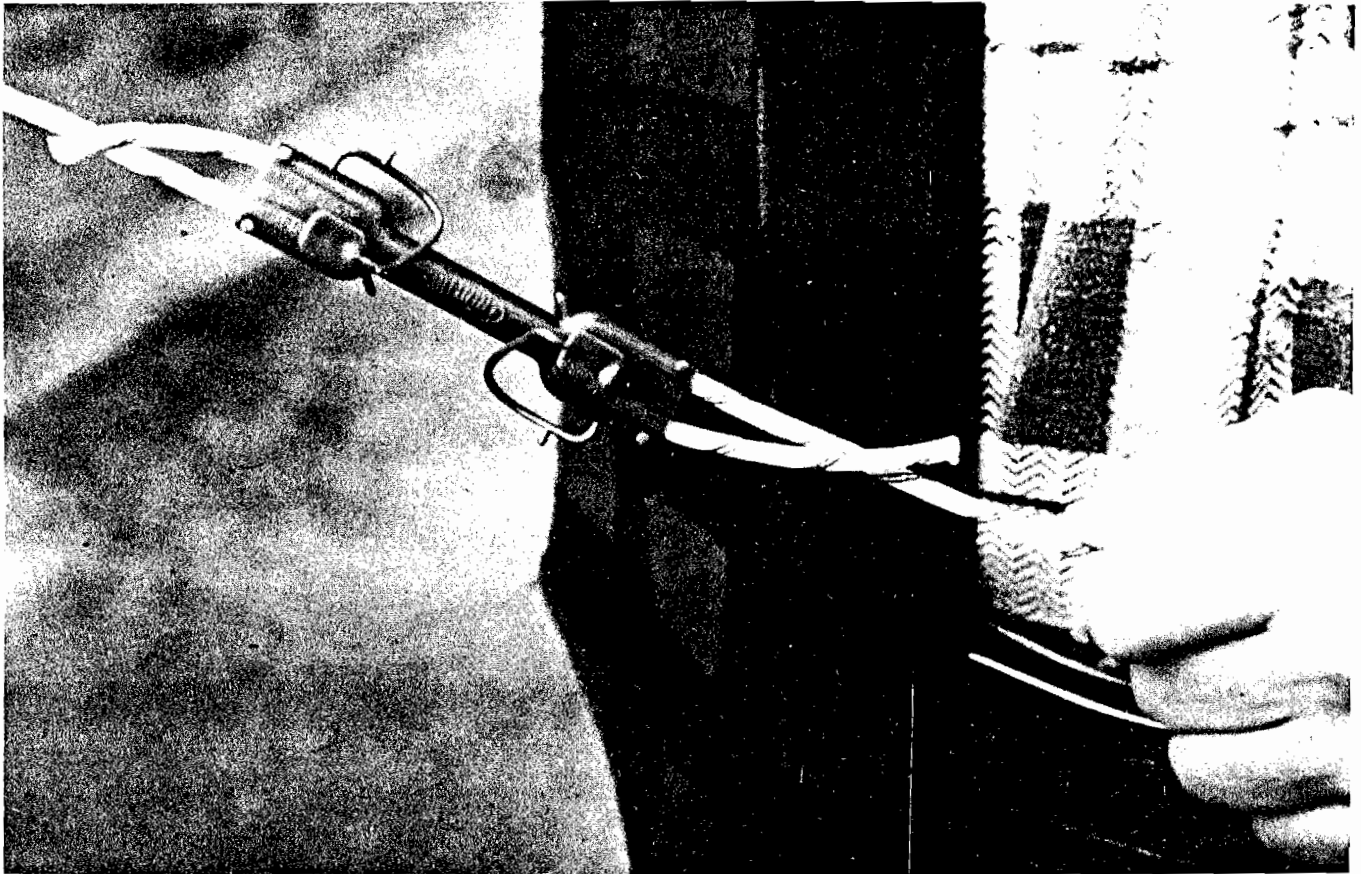

Figure 29.—Clip-on surface detonating cord delay connector. (Courtesy Hercules Inc.)

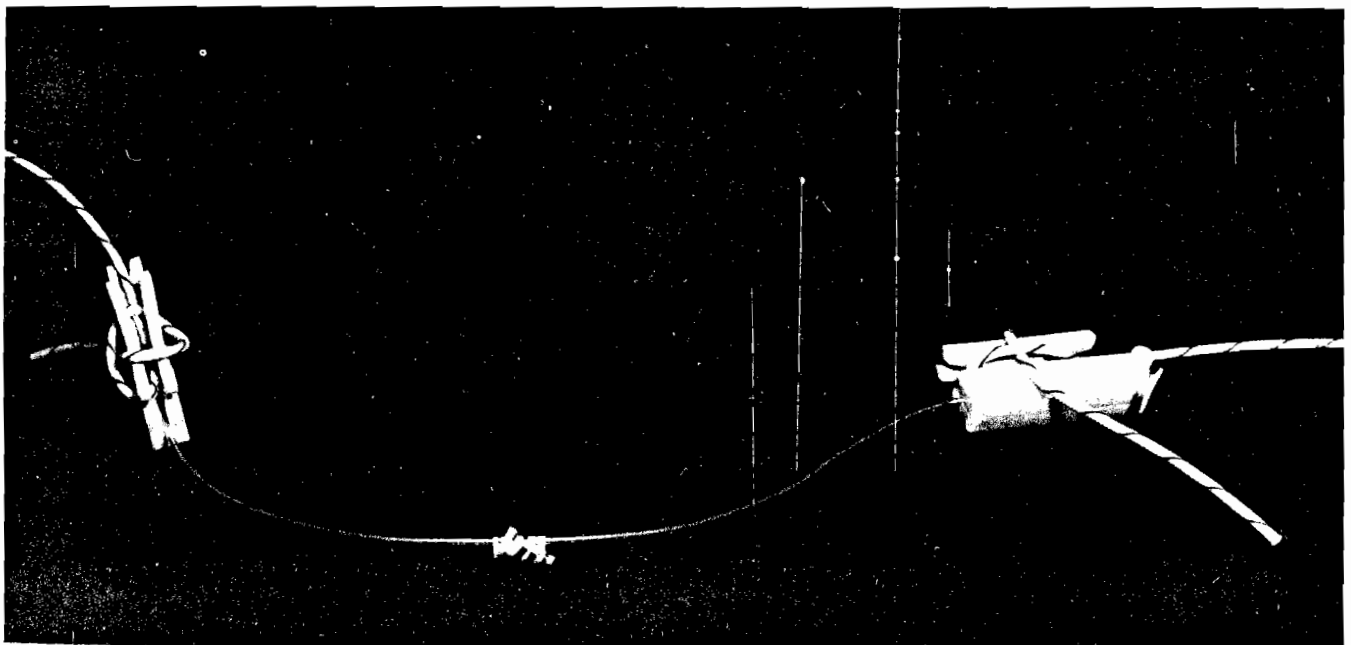

Figure 30.—Nonel surface detonating cord delay connector. (Courtesy Ensign Bickford Co.)

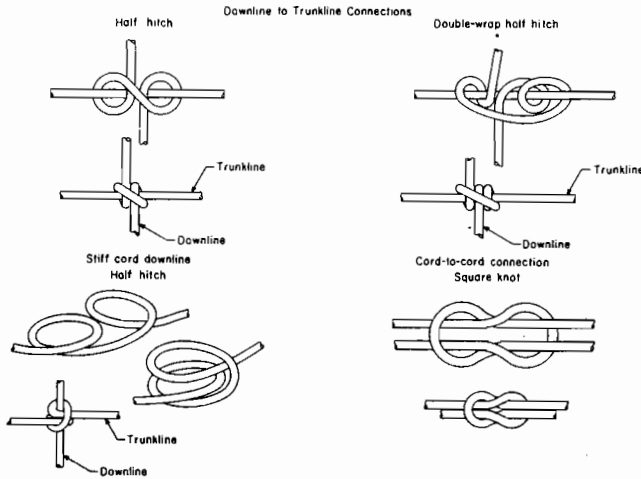

Figure 31.—Recommended knots for detonating cord.

much slack is present, the cord may cross itself and possibly cause a cutoff (fig. 32). Also, if the lines are too tight and form an acute angle, the downline may be cut off without detonating.

Downlines of detonating cord can adversely affect the column charge of explosive in the blasthole. With cap-sensitive explosives, continuous, axial initiation will occur with any cord containing 18 or more grains of PETN per foot of cord. Lower strength cords may also cause axial initiation. Four-grain cord will not initiate most cap-sensitive explosives. With blasting agents, the effect of detonating cord is less predictable. The blasting agent may be desensitized or it may be marginally initiated. Hagan (10) has studied this problem. The effect depends on the cord strength, blasting agent sensitivity, blasthole diameter, and position of the cord within the blasthole. As a general rule, 50-gr cords are compatible with blasthole diameters of 8 in or more. In charge diameters of 5 to 8 in, 25-gr or

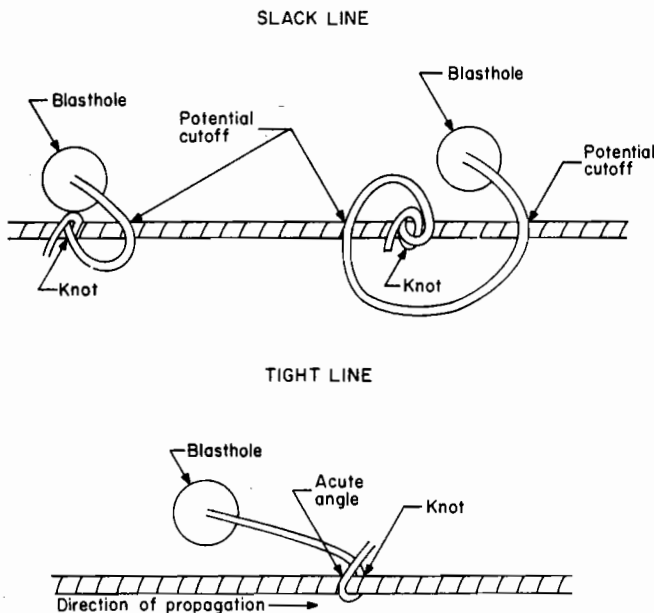

Figure 32.—Potential cutoffs from slack and tight detonating cord lines.

lighter downlines should be used. In diameters below 5 in, low-energy (4- to 10-gr) downlines or alternative, nondisruptive initiation systems are recommended. The manufacturer should be consulted for recommendations on the use of detonating cord with various explosive products. A low-energy initiation system called Detacord, developed by du Pont, is described later in this chapter.

### DELAY SYSTEMS

Surface delay connectors offer an unlimited number of delays. For instance, a row of 100 holes could be delayed individually by placing a delay between each hole and initiating the row from one end. Typical delay intervals for surface connectors are 5, 9, 17, 25, 35, 45, and 65 ms. Since these connectors are normally used for surface blasting, half-second delay periods are not available.

Cutoffs may be a problem with surface delay connectors. When the powder column in one hole detonates, the connections between holes to be fired later may be broken by cratering or other movement of the rock mass. This may cause a subsequent hole to misfire. To correct this situation, MSHA requires that the pattern of trunklines and delay connectors be designed so that each blasthole can be reached by two paths from the point of initiation of the blast round. The patterns can become somewhat complex and should be laid out and carefully checked on paper before attempting to lay them out in the field. Where possible the pattern should be designed so that the delay sequence in which the holes fire is the same no matter which path is taken from the point of blast initiation. The "Blast Design" chapter gives suggestions for selecting the actual delay intervals between blastholes.

Figure 33 shows a typical blast laid out with delay connectors. Note that each hole can be reached by two paths from the point of initiation. A time of 1 ms is required for 21 ft of detonating cord to detonate. This time is not sufficient to significantly alter the delay interval between holes.

When detonating cord downlines are used, detonation of the cord in the blasthole proceeds from the top down. This presents two disadvantages. First, the detonation of the cord may have an undesirable effect on the column charge as it proceeds downward and the stemming may be loosened. Second, if the hole is cut off by burden movement caused by detonation of an earlier hole (fig. 34) the powder in the lower portion of the hole will not detonate. The use of a Primaline

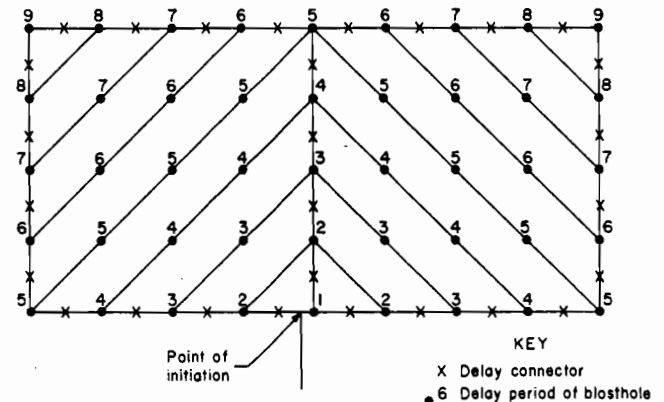

Figure 33.—Typical blast pattern with surface delay connectors.



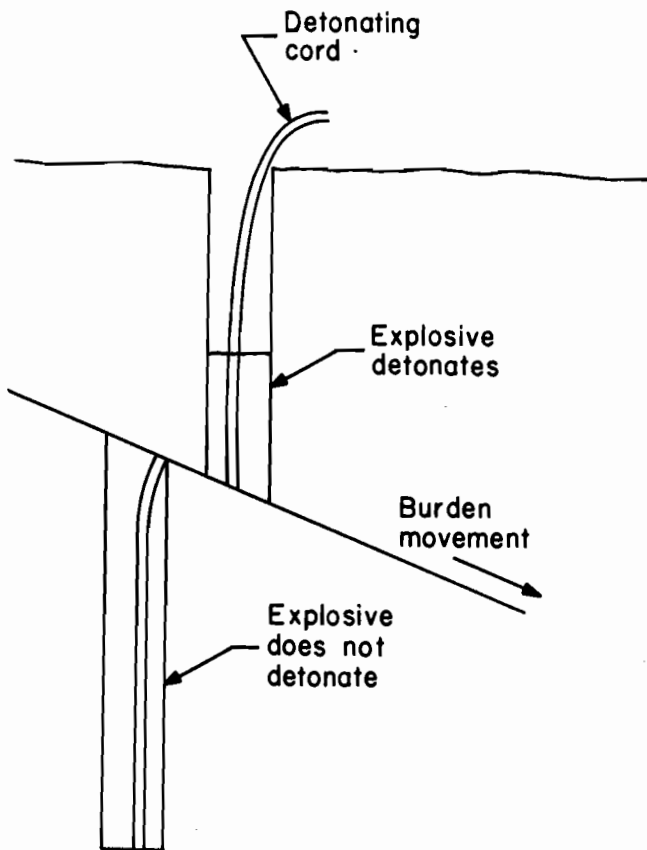

Figure 34.—Misfire caused by cutoff from burden movement.

Primadet delay unit in the hole will correct both of these problems.

The Primaline Primadet is a delay cap attached to a length of 4-gr/ft detonating cord. It is available in both millisecond and long delay periods. The Primaline Primadet is connected to the trunkline with a plastic connector or a double-wrap half hitch. If the delay pattern of the blast is such that the number of available Primadet delay periods is adequate, an undelayed trunkline may be used. The delay period of the cap would then be the delay period of the hole. As an example, to attain the delay pattern in figure 33, cap delay periods one through nine would be placed in the appropriate holes and trunklines would contain no delays. In this situation, the delay in every cap would be actuated before the first hole detonates. This would reduce the chance of a cutoff. The 4-gr Primaline Primadet is steadily being replaced by other nonelectric systems, described later in this chapter.

Another alternative to obtain the delay pattern in figure 33, and avoid the cutoff problem, would be to use the array of surface delays shown in the figure and an in-hole delay of an identical period in each blasthole. For instance, if a 75-ms delay is used in each hole, and the trunkline delays are each 9 ms, the delays in all of the holes except the two rear corner holes will be actuated before the first hole in the pattern fires, thus alleviating the cutoff problem. More complex patterns involving both surface and in-hole delays can be designed where desirable. An alternative method of obtaining in-hole delays with detonating cord is to use delay cast primers (fig. 12). These are cast primers with built-in nonelectric millisecond

and delays. They can be strung on detonating cord downlines of 25 gr or more and are particularly useful in obtaining multiple delayed deck charges with a single downline. It bears repeating that delay patterns involving both surface and in-hole delays can be somewhat complex and should be carefully laid out on paper before attempting to install them in the field.

## GENERAL CONSIDERATIONS

Two of the primary advantages of detonating cord initiation systems are their ruggedness and their insensitivity. They function well under severe conditions such as in hard, abrasive rock, in wet holes, and in deep, large-diameter holes. They are not susceptible to electrical hazards, although lightning is always a hazard while loading any blast. Detonating cord is quite safe from accidental initiation until the initiating cap or delay connectors are attached. Available delay systems are extremely flexible and reasonably accurate.

There are several disadvantages that may be significant in certain situations. Systems employing only surface connectors for delays present the potential for cutoffs. Surface connectors also present the hazard of accidental initiation by impact. Detonating cord trunklines create a considerable amount of irritating, high-frequency airblast (noise). In populated areas the cord should be covered with 15 to 20 in of fine material or alternative, noiseless systems should be used. Detonating cord downlines present the problem of charge or stemming disruption. As discussed previously, this depends on the bore-hole diameter, the type of explosive, and core load of explosive in the cord. The means of checking the system is visual examination.

Vehicles should never pass over a loaded hole because the detonating cord lines may be damaged, resulting in a misfire or premature ignition. A premature ignition could result from driving over a surface delay connector.

## DETALENE SYSTEM

Du Pont's Detaline System is a recently developed initiation system that is based on low-energy detonating cord. It functions similarly to conventional detonating cord systems except that the trunkline is low in noise, downlines will not disrupt the column of explosive, it will not initiate blasthole products, except dynamites, and all connections are made with connectors, rather than knots. The four components of the system are Detaline Cord, Detaline Starters, Detaline MS Surface Delays, and Detaline MS In-Hole Delays.

The Detaline Cord (Detacord) is a 2.4-gr/ft detonating cord whose appearance is similar to standard detonating cord. The cord is cut to lengths required for the blast pattern. This low-energy cord, while low in noise, has sufficient energy to disintegrate the cord upon detonation, which is advantageous where contamination of the blasted product must be avoided. Detacord will not propagate through a knot, which is why connectors are required. To splice a line or to make a nondelayed connection, a Detaline Starter is required. The body of the starter is shaped much like a clip-on detonating cord millisecond delay connector, except that the starter is shaped like an arrow to show the direction of detonation. To make a splice, the starter is connected to the two ends of the Detacord using the attached sawtooth pin, making sure that the arrow points in the direction of detonation. To make a connection, the donor trunkline is hooked into the tail of the starter and the acceptor trunkline, or downline, is hooked into the pointed end of the connector.

The Detaline System has provisions for both surface and in-hole delays. The surface delays, which come in periods of 9, 17, 30, 42, 60, and 100 ms, are shaped like the starter but are colored according to the delay. The surface delays are also unidirectional, with the arrow showing the direction of detonation. The surface delays can be hooked into a trunkline in which case their function is similar to that of a standard millisecond delay connector. They can also be used as starters, connected between the trunkline and downline at the collar of the blasthole. In this situation the delay affects only the downline, and not the trunkline.

A Detaline MS In-Hole Delay resembles a standard blasting cap except for a special top closure for insertion of the Detacord. It functions similarly to a surface delay. Nineteen delay periods, ranging from 25 to 1,000 ms, are available. The delay is connected to the downline and is inserted into the primer.

Hookup of the Detaline System is similar to conventional detonating cord except that connectors are used rather than knots and right-angle connections are not necessary. When it is time to hook up, the Detaline trunkline is reeled out over the length of each row. Each downline is connected to the arrow end of a starter or a surface delay. The tail of each starter or surface delay is then connected into the trunkline. The open sides of the pattern are then connected in a manner similar to conventional detonating cord systems using Detacord and appropriate starters and surface delays. It is essential that all

Detacord-to-Detacord connections be made with starters or surface delays rather than knots.

The Detaline System bears many similarities to conventional detonating cord systems. The system is checked out visually before firing. Combining surface and in-hole delays gives a practically unlimited number of delay combinations. It is convenient to build redundancy into the system. At firing time, the end of the trunkline tail extending from the shot is placed into the arrow end of a starter, and an electric or fuse blasting cap is inserted into the tail end of the starter and initiated.

The detonation energy of the 2.4-gr Detacord is adequate to disintegrate the trunkline. However, the resulting trunkline noise is quite low; typically about 13 dB lower than 25-gr detonating cord in field trials. A downline of Detacord will detonate most dynamites but will not detonate most water gels. A major advantage of a Detacord downline is that it will not disrupt a column of blasting agent. Detacord can be used as a total system or in conjunction with some standard detonating cord components. As with most newer systems, evolutionary changes may occur in the coming years. It is important that the manufacturer be consulted for recommended procedures for using Detacord. The manufacturer will also be able to recommend which variation of the system best suits a particular field situation.

## CAP-AND-FUSE INITIATION

Cap and fuse is the oldest explosive initiation system; however, its use has dwindled steadily. Its primary remaining use is in small underground mines, although a few large mines still use it. Surface applications are limited to secondary blasting and the initiation of detonating cord rounds with a single cap.

### COMPONENTS

The detonator used in a cap-and-fuse system is a small capsule that is open at one end (fig. 35). The capsule contains a base charge and a heat-sensitive primer charge of explosive. The powder charge in the cap is initiated by a core of flammable powder in the safety fuse. Safety fuse has an appearance somewhat similar to detonating cord except that the surface of safety fuse is smoother and more waxy and the core load is black. The core load of detonating cord is white.

To assemble a cap and fuse, the fuse is carefully cut squarely and inserted into the cap until it abuts against the explosive charge in the cap. The fuse should never be twisted against the explosive charge in the cap. The cap is then crimped near the open end with an approved hand or bench crimper. The

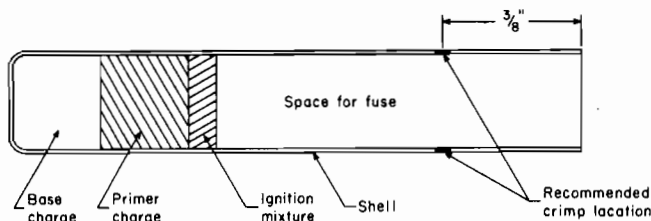

Figure 35.—Blasting cap for use with safety fuse.

crimp should be no more than three-eighths of an inch from the open end of the cap.

### FIELD APPLICATIONS

Currently, all safety fuse burns at the nominal rate of 40 sec/ft. Both dampness and high altitude will cause the fuse to burn more slowly. Fuse should be test burned periodically so that the blaster can keep a record of its actual burning rate. "Fast fuse" has been blamed for blasting accidents but the fact is that this rarely if ever occurs. However, pressure on the fuse may increase its burning rate.

One of the most important considerations in the use of cap-and-fuse systems is the use of a positive, approved lighting mechanism. Matches, cigarette lighters, carbide lamps, or other open flames are not approved for lighting fuse. MSHA regulations specify hotwire lighters, lead spitters, and Ignitacord as approved ignition systems. The safest, most controllable lighting method is Ignitacord. In South Africa, where safety fuse is most often sold as an assembly with an Ignitacord connector attached, the safety record with cap and fuse is much better than it is in the United States.

The Ignitacord connector fits over the end of the fuse and is crimped in a manner similar to the cap. Figure 36 shows a typical cap, fuse, and Ignitacord assembly. The cap is attached to the fuse with a bench or hand crimper, and never with the teeth or pliers. When crimping the cap, care should be taken not to crimp the zone containing the powder. The Ignitacord connector is crimped to the other end of the fuse with a hand crimper. The Ignitacord is inserted into the notch near the end of the connector and the notch is closed using the thumb.

To guard against water deterioration, it is a good idea to cut off a short length of fuse immediately before making cap-and-

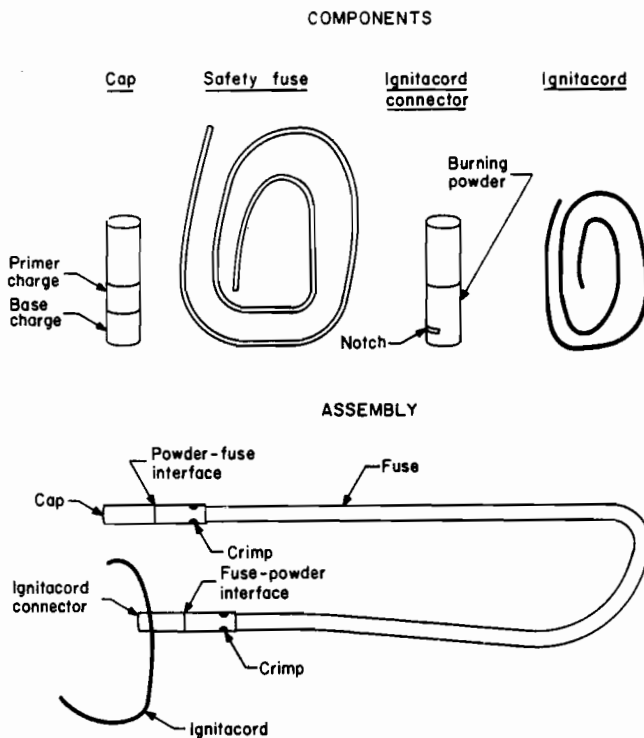

Figure 36.—Cap, fuse, and Ignitacord assembly.

fuse assemblies. In deciding the length of fuse to cut for each primer, the lighting procedure must be considered. Ignitacord is strongly recommended because of its safety record.

When Ignitacord is used, each fuse must have a burning time of at least 2 min. To make sure of this time, the fuse must be calibrated periodically by test burning. The Ignitacord is attached to the Ignitacord connectors in the desired order of firing. If all the fuses are cut accurately to the same length, the desired order of firing will be achieved.

With Ignitacord, only one lighting is required before the shotfirer returns to a safe location. Hotwire lighters and lead spitters require that each fuse be lit individually. The primary hazard of using safety fuse is the tendency of blasters to linger too long at the face, making sure that all the fuses are lit. To guard against this, MSHA regulations specify minimum burning times for fuses, depending on how many fuses one person lights. Keep in mind that two persons are required to be at the face while lighting fuse rounds.

If a person lights only one fuse, the minimum burning time is 2 min; for 2 to 5 fuses the minimum is 2-2/3 min; for 6 to 10 fuses the minimum is 3-1/3 min; and for 11 to 15 fuses the

minimum is 5 min. One person may not light more than 15 fuses in a round. Although individual fuse lengths may be varied for delay purposes it is more dependable to cut all the fuses to the same length and use the sequence of lighting to determine the firing sequence.

To avoid misfires due to cutoff fuses, MSHA requires that the fuse in the last hole to fire is burning within the hole before the first hole fires. Kinks and sharp bends in the fuse should be avoided because they may cut off the powder train and cause a misfire. Many people who use cap and fuse do so because they feel that it is simpler to use than other initiation systems. However, proper use of cap and fuse requires as much or more skill and care as the other systems.

## DELAYS

Cap and fuse is the only initiation system that offers neither flexibility nor accuracy in delays. Because of variations in lengths of fuse, burning rates, and time of lighting the individual holes will fire at erratic intervals at best, and out of sequence at worst. It is impossible to take advantage of the fragmentation benefits of millisecond delays when using the cap-and-fuse system.

## GENERAL CONSIDERATIONS

There is no situation in which cap and fuse can be recommended as the best system to use. The system has two overpowering flaws—inaccurate timing and a poor safety record. The former results in generally poor fragmentation, a higher incidence of cutoffs, and less efficient pull of the round. All of these factors nullify the small cost advantage derived from the slightly lower cost of the system components. The poor safety record attained by cap and fuse is an even more serious drawback. It is the only system that requires the blaster to activate the blast from a hazardous location and then retreat to safety. The use of Ignitacord rather than individual fuse lighting alleviates this problem. A Bureau study (14) determined that the accident rate with cap and fuse is 17 times that of electric blasting, based on the number of units used. Too often, the person lighting the fuse is still at the face when the round detonates. The time lag between lighting the fuse and the detonation of the round makes security more difficult than with other systems.

Cap and fuse does have the advantages of lack of airblast, no charge disruption, somewhat lower component costs, and protection from electrical hazards. If an operator decides to use the cap-and-fuse system, incorporation of Ignitacord for lighting multiple holes is strongly recommended because of its safety record.

## OTHER NONELECTRIC INITIATION SYSTEMS

Beginning about in 1970, efforts were devoted toward developing new initiation systems that combined the advantages of electric and detonating cord systems. Basically, these systems consist of a cap similar to an electric blasting cap, with one or two small tubes extending from the cap in a manner similar to leg wires. Inside these tubes is an explosive material that propagates a mild detonation which activates the cap.

Delay periods similar to those of electric blasting caps are available except that there are no coal mine delays, since these devices are not approved for use in underground coal mines. These initiation systems are not susceptible to extraneous electricity, create little or no airblast, do not disrupt the charge in the blasthole, and have delay accuracies similar to those of electric or detonating cord systems (5).

At the time this manual was written, two relatively new nonelectric initiation systems—Hercudet and Nonel—were on the market. Other nonelectric systems are either under development or in the conception stage. Both Hercudet and Nonel were introduced to the U.S. market in the mid-1970's. Because of their relative recency, minor changes are still being made in these systems. The following discussions are intended to give only general information on the systems. Persons planning to use the systems should contact the manufacturers, Hercules Inc. and Ensign Bickford Co., respectively, for specific recommendations on their use. A third system, du Pont's Detaline System, is discussed in the "Detonating Cord Initiation" section of this chapter.

### HERCUDET

The hookup of the Hercudet (also called gas detonation) blasting system resembles a plumbing system. The cap is higher strength than most electric blasting caps. Both millisecond and long delays are available. Instead of leg wires, two hollow tubes protrude from the cap. The cap may be used in a primer in the hole or at the collar of the hole for initiating detonating cord downlines. In addition to the Hercudet cap, system accessories include duplex trunkline tubing, single trunkline tubing; various types of tees, connectors, ells, and manifolds for hooking up the system; circuit testers; a gas supply unit containing nitrogen, oxygen, and fuel cylinders; and a blasting machine. The system functions by means of the low-energy detonation of an explosive gas mixture introduced into the hollow tubes. This low-energy detonation does not burst or otherwise affect the tubing.

For surface blasting, a cap with 4-in leads is used (fig. 37). For surface initiation of detonating cord downlines this cap is connected directly to the trunkline tubing by means of the reducing connector that is factory-attached to the cap. The reducing connector is needed because the trunkline tubing is larger than the capline tubing. A special plastic connector is used to attach the cap to the detonating cord downline.

When in-hole initiation is desired, the 4-in cap leads are extended by connecting them to an appropriate length of larger diameter duplex trunkline tubing (fig. 38). This trunkline tubing is cut squarely, leaving 2 to 3 ft of tubing extending from the borehole collar, and a plastic double ell fitting is inserted. Trunkline tubing is later connected hole to hole. Figure 39 shows typical Hercudet connections for surface blasting with in-hole delays.

Not all cast primers have tunnels large enough to accept the Hercudet duplex tubing. This should be checked before purchasing cast primers. When using cartridge primers with Hercudet, the tubing is taped to the primer, not half-hitched to it.

For underground blasting, millisecond and long period delay caps are available with 16- to 24-ft lengths of tubing. The tubes are cut to the appropriate length by the blaster. The tubes are then connected in series or series-in-parallel, similar to electric cap circuits, using capline connectors and manifolds instead of the wire splices used in electric blasting. In all Hercudet blasting circuits, the tubing at the end of each series is vented to the atmosphere. The tubing network should be kept free of kinks.

When the circuit has been hooked up, a length of trunkline tubing is strung out to the firing position, similar to the firing line in an electric system. At this time nitrogen from the gas supply

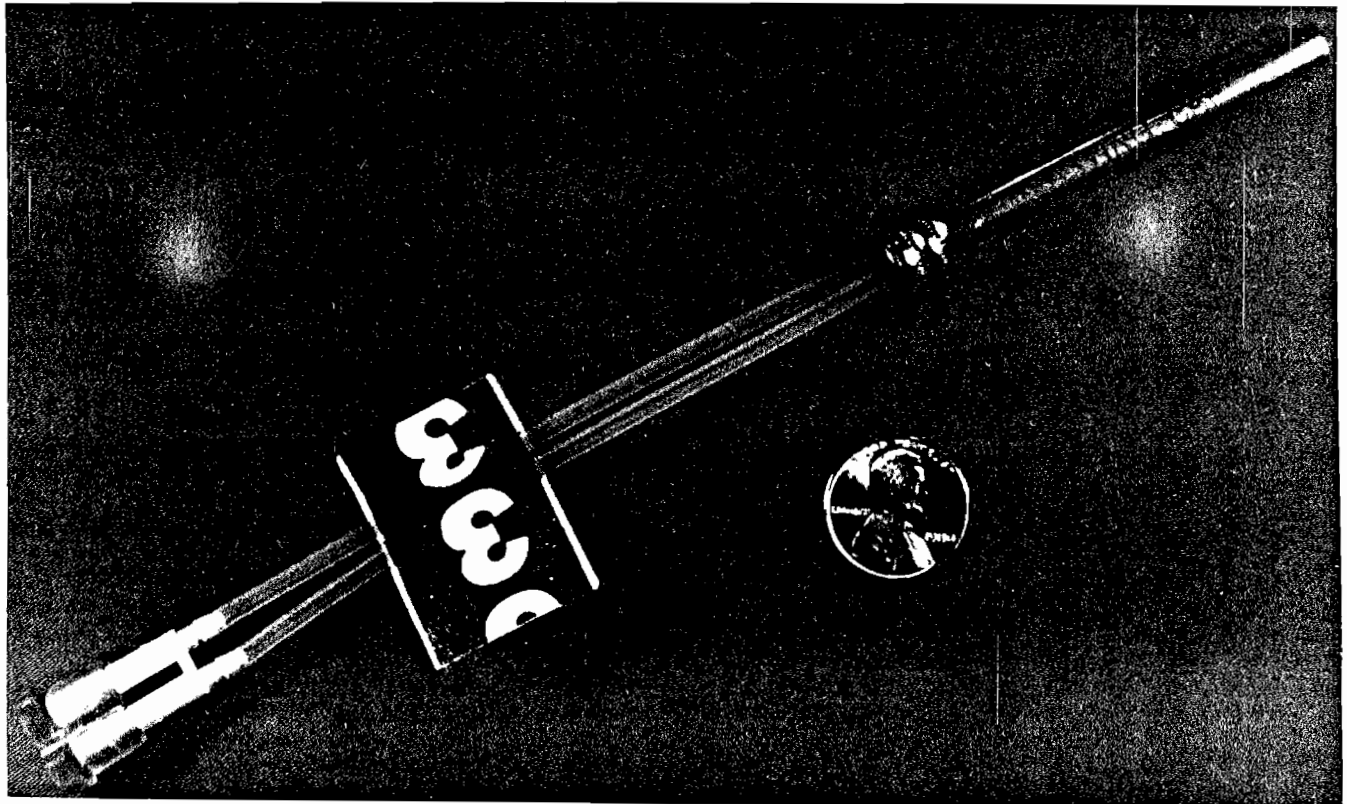

Figure 37.—Hercudet blasting cap with 4-in tubes. (Courtesy Hercules Inc.)

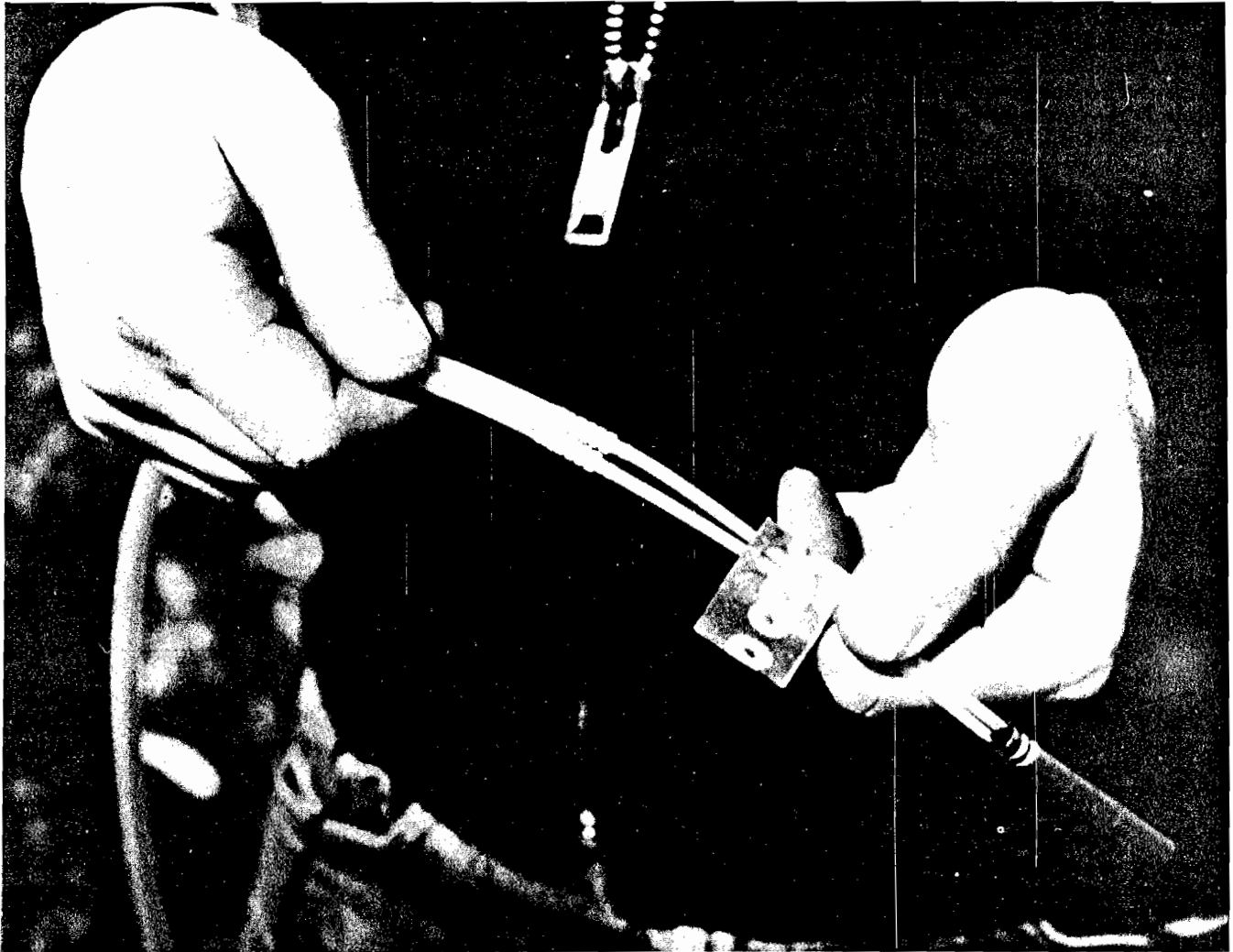

Figure 38.—Extending Hercudet leads with duplex tubing. (Courtesy Hercules Inc.)

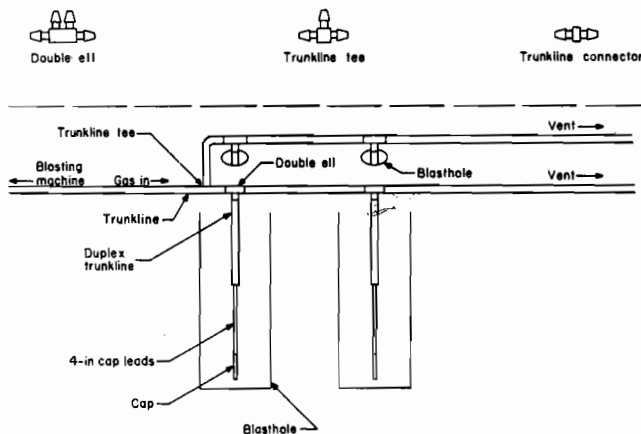

Figure 39.—Hercudet connections for surface blasting.

unit is turned on and the pressure test module is used to check the integrity of the tube circuit (fig. 40). The tester uses flow and/or pressure checks to locate blockages or leaks in the circuit. As with a galvanometer in electric blasting, each series should be checked individually, followed by a check of the entire system. The Hercudet tester is a smaller unit than the pressure test module and uses a hand air pump to test single boreholes or small hookups (fig. 41). If a plug or a leak is detected when checking the completed circuit, the circuit is broken into segments and checked with the Hercudet tester or pressure test module.

Once the system has been checked and the blast is ready to fire, the blasting machine, connected to the bottle box (gas supply unit), is used to meter a fuel and oxidizer mixture into the firing circuit (fig. 42). Until this detonable gas mixture is put into the tubes, the connections between the caps are totally inert. The explosive gas must be fed into the system for an adequate period of time to assure that the system is entirely filled. Gas feeding continues until the blaster is ready to fire the shot. The time required to charge the circuit with gas depends on the size of the circuit.

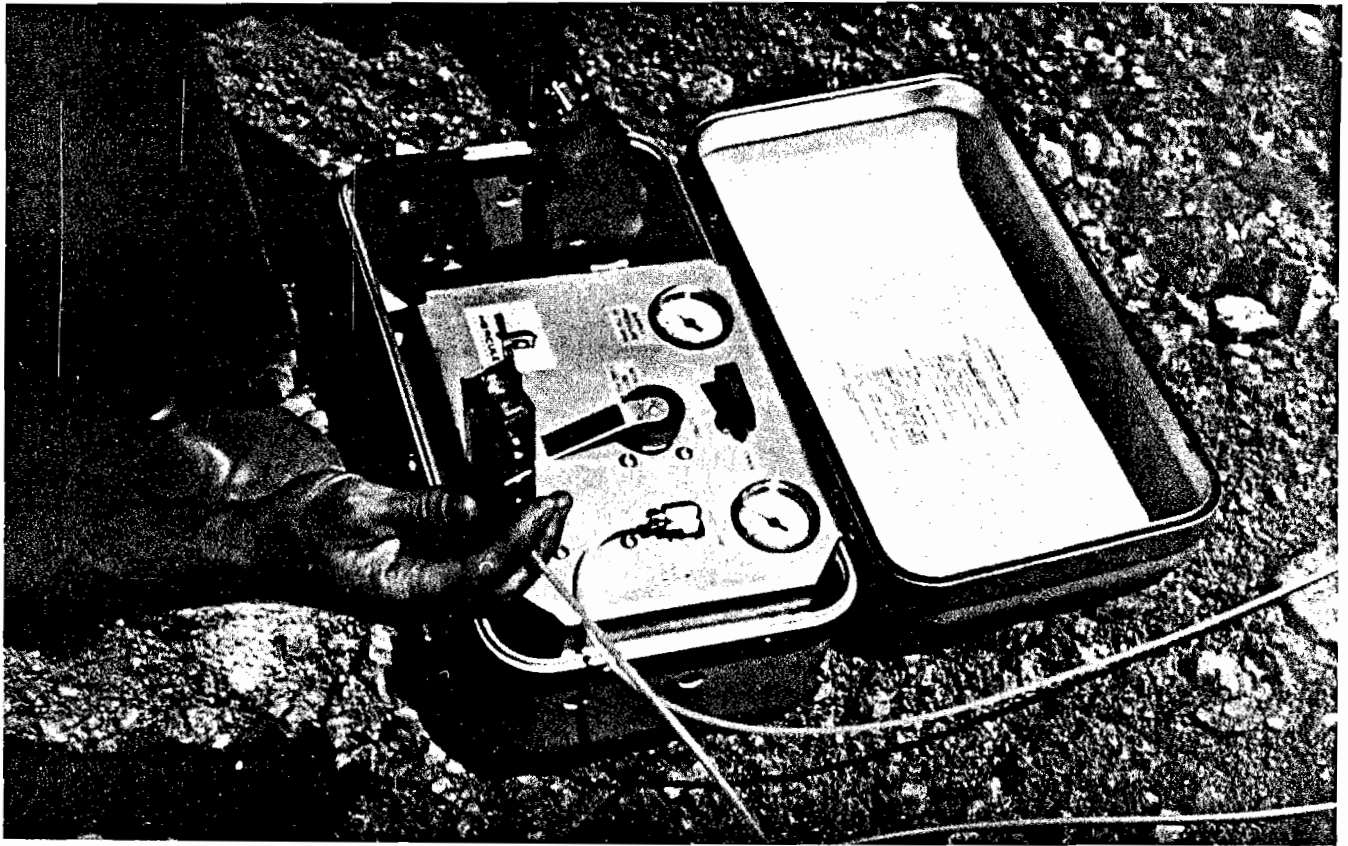

Figure 40.—Hercudet pressure test module. (Courtesy Hercules Inc.)

When the system has been charged, the blasting machine control lever is moved to "arm" and the "fire" button is pushed, causing a spark to ignite the gas mixture. A low-energy gas detonation travels through the tubing circuit and through the air space inside the top of each individual cap at a speed of 8,000 fps and ignites the delay element in the cap.

The relatively slow (8,000 fps) detonation rate of the gas introduces an additional delay element into the system. For instance, assuming a gas detonation rate of 8 ft/ms, with caps at a depth of 30 ft in blastholes spaced 12 ft apart (a total travel path of 72 ft from cap to cap), a 9-ms delay between caps will be introduced by the tubing. It is essential that these tube delays be taken into account when calculating the actual firing times of the individual caps. Although the calculations are not complex, it is important that they are done carefully, before hooking up the blast, to avoid possible errors in the last minute rush to get the shot off. The delay time of the tubing can be used to advantage by coiling tubing in the trunkline at any location where an additional surface delay is desired.

The Hercudet system has the advantages of no airblast, no charge disruption, no electrical hazards, versatile delay capability, and system checkout capability. The inert nature of the system until the gas is introduced is a safety benefit. Specific crew training by a representative of the manufacturer is necessary because the system is somewhat different in principle than the older systems such as detonating cord and electric blasting. Care must be taken not to get foreign material such as dirt or water inside the tubing or connector while hooking up the shot, and to avoid knots or kinks in the tubing.

## NONEL

The hookup of the Nonel (also called the shock tube) system is similar in some respects to the detonating cord system. The cap used in the system is higher strength than most electric blasting caps. Instead of leg wires, a single hollow tube protrudes from the cap (fig. 43). The Nonel tube has a thin coating of reactive material on its inside surface, which detonates at a speed of 6,000 fps. This is a very mild dust explosion that has insufficient energy to damage the tube. Several variations of the Nonel system can be used, depending on the blasting situation. In addition to the Nonel tube-cap assembly, system accessories include noiseless trunklines with built-in delays, noiseless lead-in lines, and millisecond delay connectors for detonating cord trunklines.

One Nonel system for surface blasting uses a Nonel Primadet in each blasthole with 25- to 60-gr/ft detonating cord as a trunkline. The Nonel cap used in this system is factory crimped to a 24-in length of shock tube with a loop in the end (fig. 44). The caps are available in a variety of millisecond delay periods. A 7.5-gr detonating cord downline is attached to the loop with a double-wrapped square knot. The 7.5-gr detonating cord extends out of the borehole. This downline will not disrupt a column charge of blasting agent but it may initiate dynamite and other cap-sensitive products. As a precaution, 7.5-gr to 7.5-gr connections should never be made, because propagation from one cord to the other is not dependable. Since the force of the shock tube detonation is not strong enough to disrupt the tube, it will not initiate high explosives. A 25- to 60-gr trunkline is

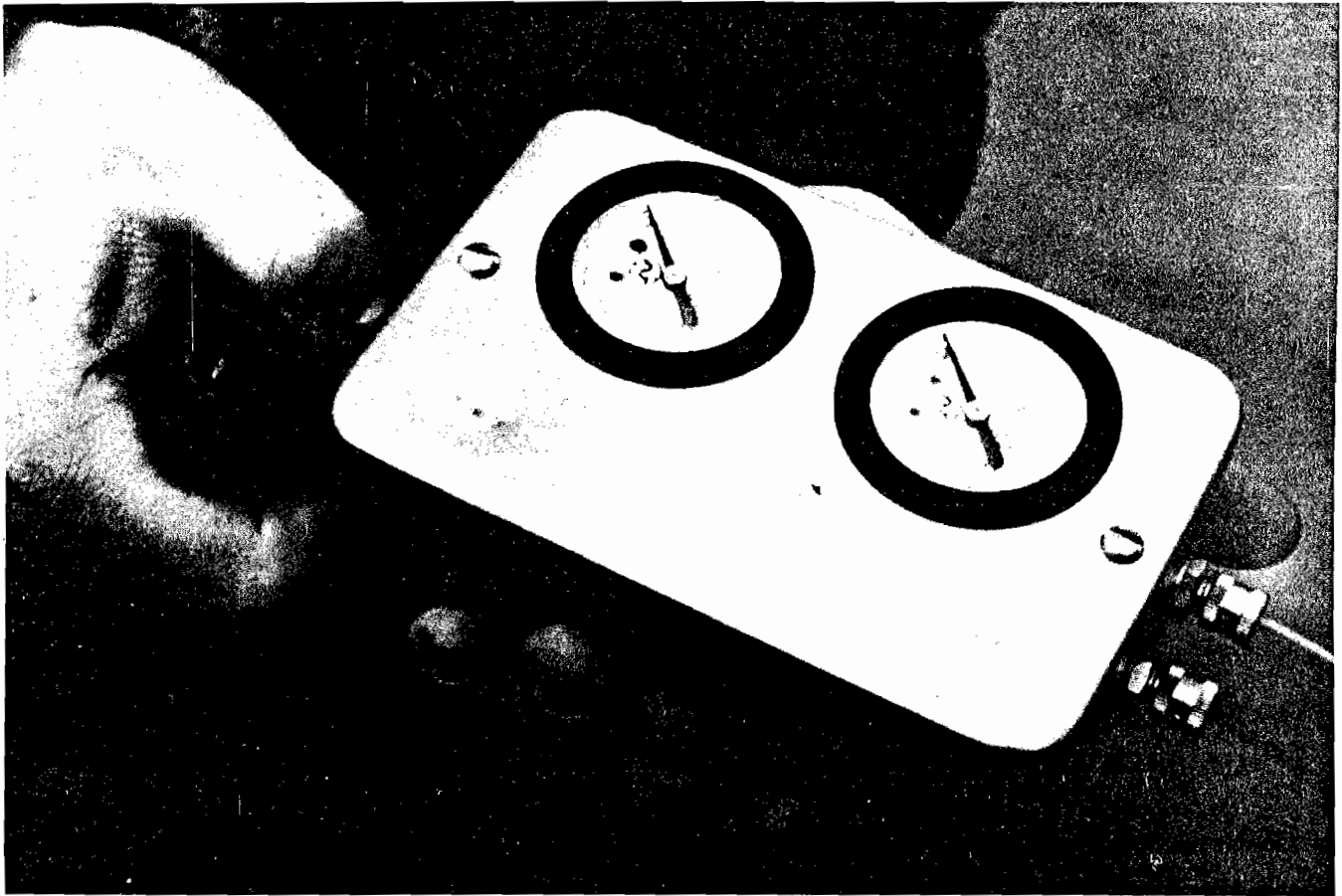

Figure 41.—Hercudet tester for small hookups. (Courtesy Hercules Inc.)

used in this system with a double clove hitch used for downline-to-trunkline connections. The delay systems used with this method of initiation are the same as those discussed in the "Detonating Cord Initiation" section. They include in-hole cap delays and surface delay connectors.

In some cases this system creates an excessive amount of airblast and noise. To prevent this, the detonating cord trunkline can be replaced by an electric blasting cap circuit with a cap connected to each downline, or a noiseless Nonel trunkline can be used.

The noiseless Nonel trunkline is employed as follows. First, each hole is primed and loaded. The downline should be an 18-gr or larger detonating cord. A 7.5-gr downline can be used if a 25-gr pigtail is used at the top end, tied into the connector block. The noiseless trunkline delay unit consists of a length of shock tube, 20 to 60 ft in length, with a quick connecting sleeve on one end and a plastic block containing a millisecond delay blasting cap (delay assembly) on the other end, and a tag denoting the delay period (fig. 45). The delay may be from 5 to 200 ms.

The sleeve is attached to the initial hole to be fired and the shock tube is extended to the next hole in sequence. The downline from this next hole is connected to the plastic block containing the delay cap, using about 6-in of cord at the end of the downline. Another delay unit is selected and the sleeve is attached to the downline below the plastic block. The shock tube is extended to the next hole, where the delay assembly is

connected to the downline. The process is repeated until all the holes are connected. Figure 46 shows a portion of a shot hooked up in this way.

The downlines and the plastic blocks containing the delay cap should be covered to reduce noise and flying shrapnel. When the blaster is ready to fire the shot, an initiating device is attached to the downline of the first hole. This device may be an electric blasting cap, a cap and fuse, or a Nonel noiseless lead-in (fig. 47). A noiseless lead-in is a length of shock tube, up to 1,000 ft long, crimped to an instantaneous blasting cap. The shock tube is initiated by using an electric blasting cap, cap and fuse, or other initiating device recommended by the manufacturer.

For underground blasting, millisecond and long period delay caps are available with 10- to 20-ft lengths of shock tube attached. Common practice is to use a trunkline of 18- or 25-gr detonating cord. The Nonel tube from each blasthole is attached to the trunkline with a J-connector. A simpler method is to use the bunching system, where up to 30 tubes are tied together parallel, in a bunch, and detonating cord is clove-hitched around the bunch. The manufacturer should be consulted to demonstrate the bunching technique and to determine the number of wraps of detonating cord required for a given size bunch.

When pneumatic loading is used, a plastic cap holder can be utilized to center the cap in the hole and to reduce movement of the cap. It is important that the Nonel tube is in a

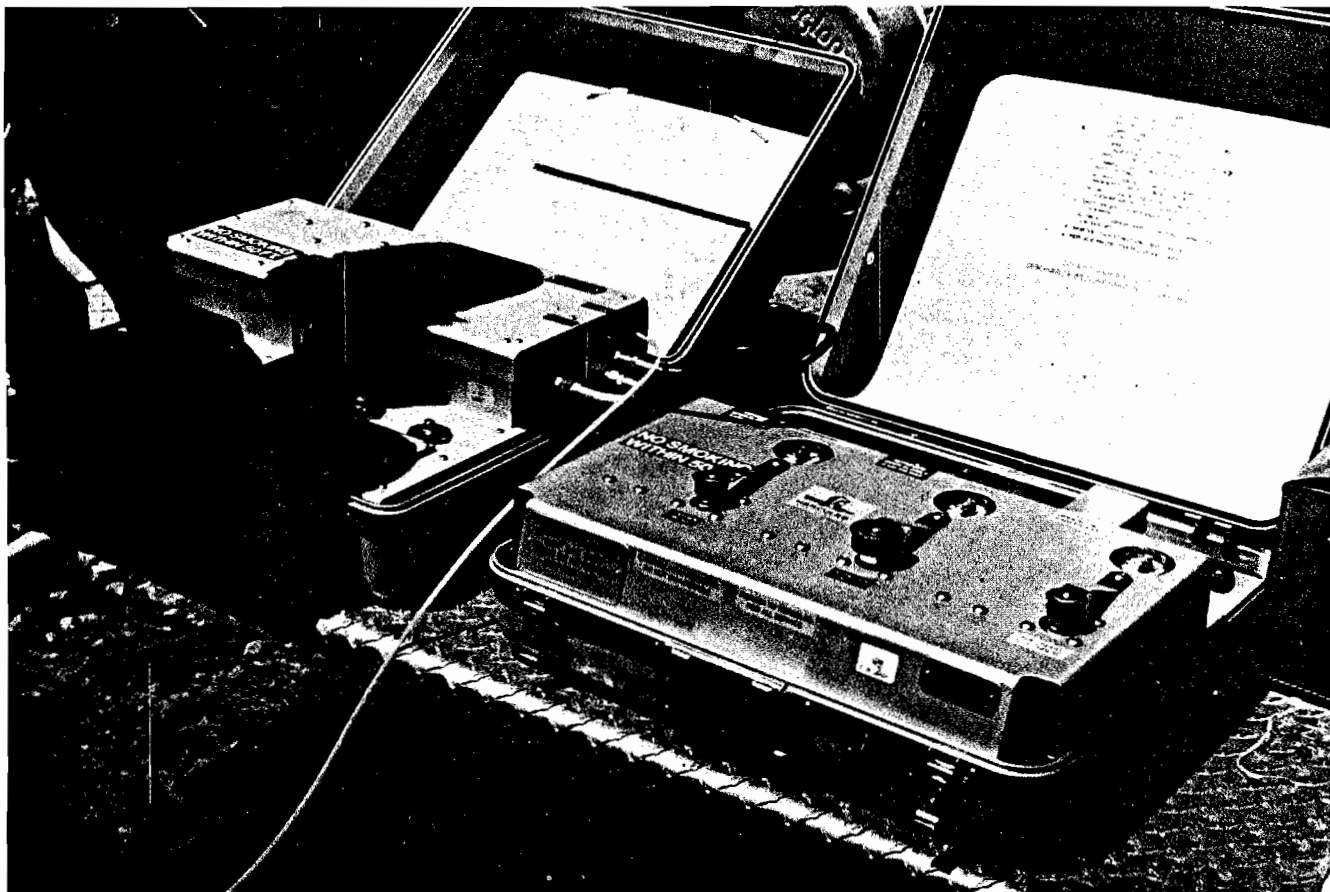

Figure 42.—Hercules bottle box and blasting machine. (Courtesy Hercules Inc.)

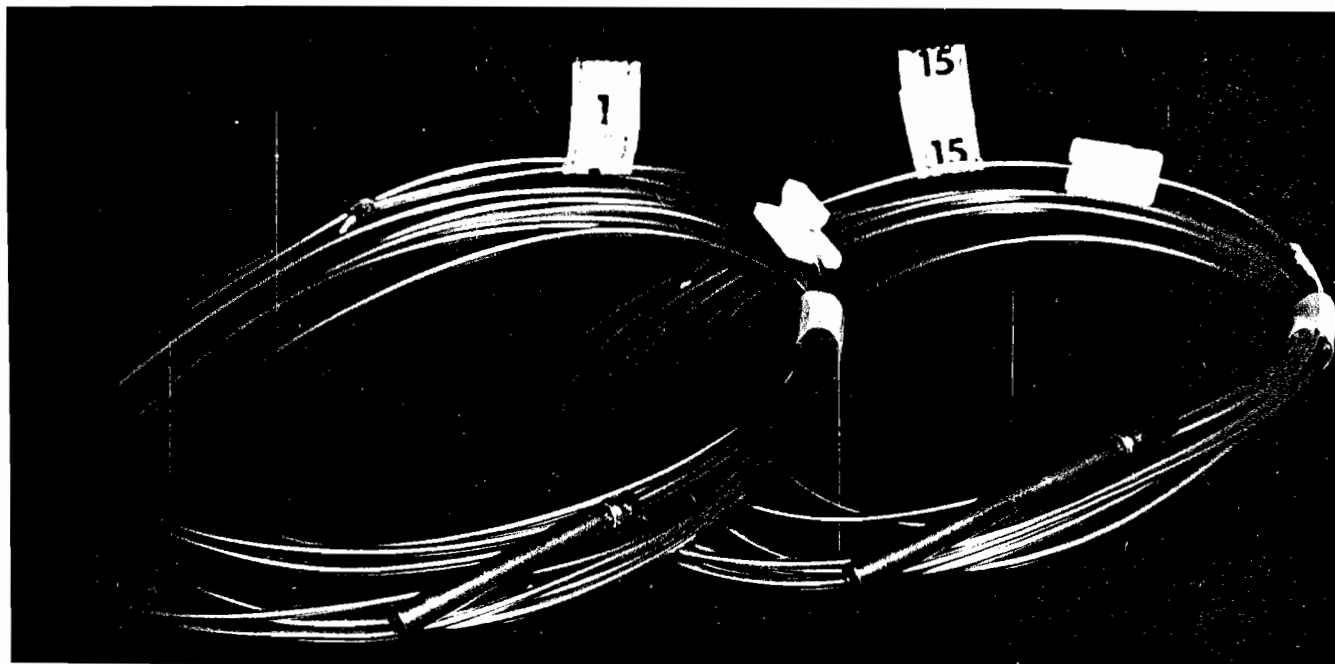

Figure 43.—Nonel blasting cap. (Courtesy Ensign Bickford Co.)



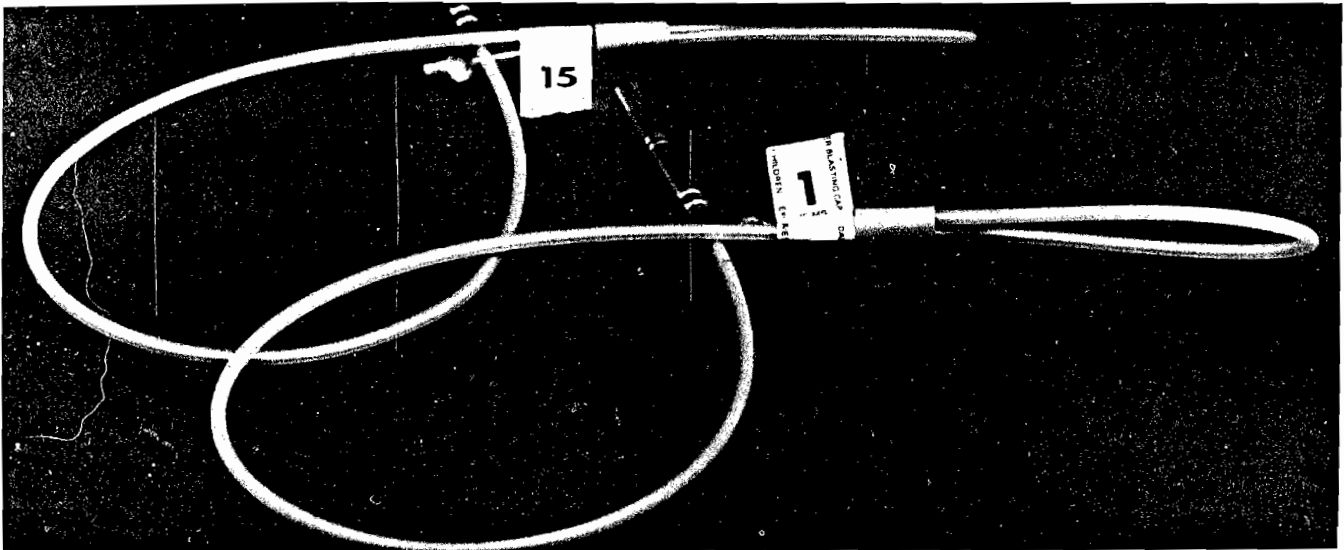

Figure 44.—Nonel Primadet cap for surface blasting. (Courtesy Ensign Bickford Co.)

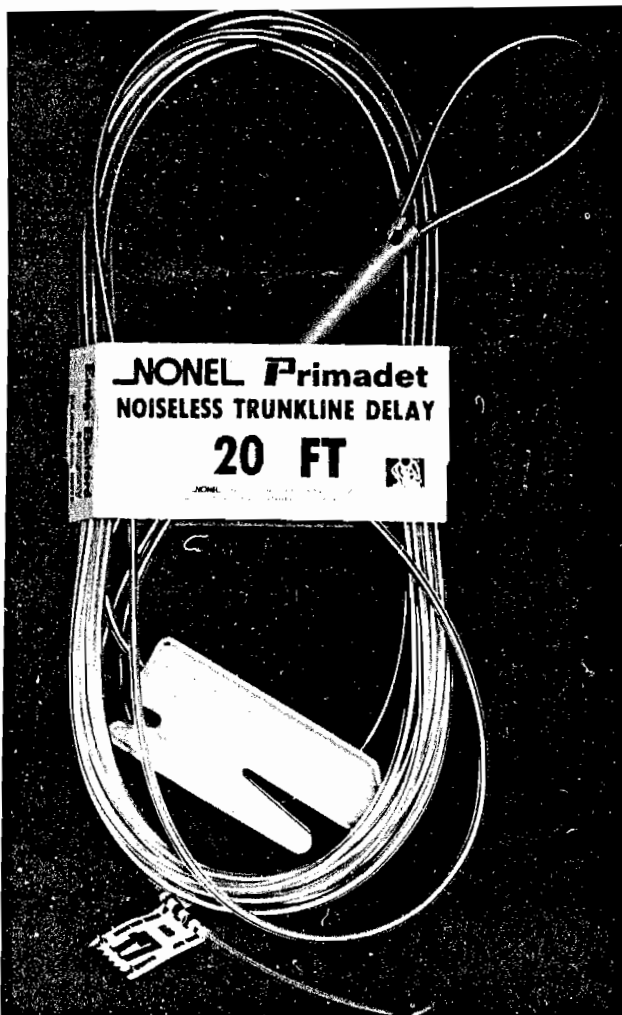

Figure 45.—Nonel noiseless trunkline delay unit. (Courtesy Ensign Bickford Co.)

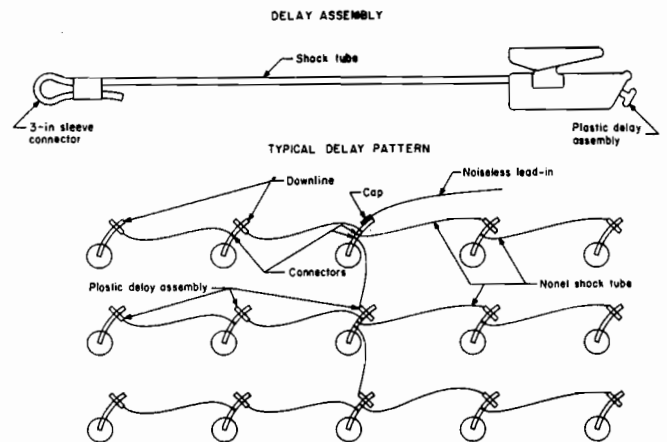

Figure 46.—Noiseless trunkline using Nonel delay assemblies.

straight line, fairly taut, and that crossovers or contact with the trunkline are avoided. This is true in all Nonel blasting but particularly in heading rounds, where the blast face is more crowded. Just before blasting, an electric cap or cap and fuse is connected to the trunkline.

The Nonel system has the advantages of no airblast (when a noiseless trunkline is used), no charge disruption (when Nonel tube or a 7.5-gr cord in conjunction with a Nonel Primadet is used as a downline), no electrical hazards, and a versatile delay capability. Keep in mind that electrical storms are a hazard with any initiation system. System checkout is done through visual inspection. Nonel shock tube assemblies should never be cut or trimmed, as that may cause the system to malfunction. The shock tube will initiate nothing but the cap crimped onto it. Because of the variations available and new concepts involved, specific crew training by a manufacturer's representative is highly recommended before using the Nonel system.

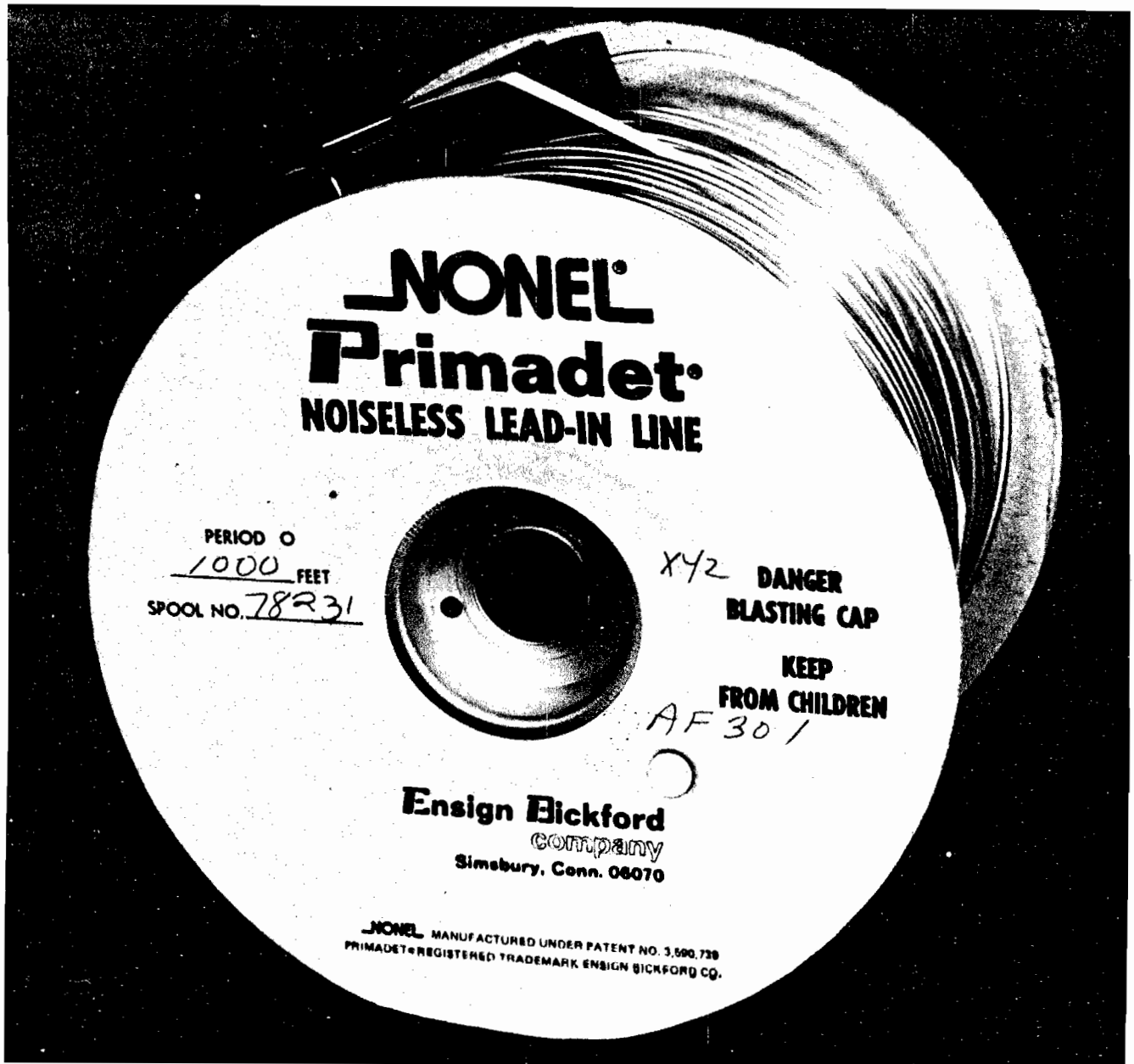

Figure 47.—Nonel noiseless lead-in line. (Courtesy Ensign Bickford Co.)

## PRIMING

Essentially, the term primer is used to describe a unit of cap-sensitive explosive that contains a detonator, while the term booster describes a unit of explosive that may or may not be cap sensitive, and is used to intensify an explosive reaction but which does not contain a detonator. Although a primer is generally thought of as containing a blasting cap, the primer cartridge may also be detonated by a downline of detonating cord.

The possible undesirable effect of the cord on blasting agents, described in the "Detonating Cord Initiation" section, must be considered. If the column charge is cap sensitive, detonating cord will cause initiation to proceed from the top

down. The manufacturer should be consulted to determine the minimum strength detonating cord that will reliably initiate a specific type of primer. Most cast primers require a detonating cord strength greater than 25 gr/ft for reliable initiation.

## TYPES OF EXPLOSIVE USED

The primer should have a higher detonation velocity than that of the column charge being primed. Some experts feel that priming efficiency continues to increase as the primer's

detonation velocity increases. In blastholes of 3-in diameter and less, cartridge dynamites and cap-sensitive cartridge slumies are commonly used as primers. For maximum efficiency, the diameter of the cartridge of explosive should be as near to the blasthole diameter as can be conveniently loaded. Gelatin dynamites are preferred over granular types because of their higher density, velocity, and water resistance. Some granular dynamites may be desensitized when subjected to prolonged exposure to water or to the fuel oil in AN-FO. Cast primers (fig. 11) may be used if the borehole is large enough to accommodate them. Small units of explosive that fit directly over the shell of a blasting cap can be used for priming bulk blasting agents in small-diameter holes. In some situations, where

boreholes are dependably dry, a high-strength cap alone has been used to prime a bulk-loaded AN-FO in a small-diameter hole. However, it is strongly recommended that a small booster fitting directly over the shell of the cap be used rather than a high-strength blasting cap alone. The cap manufacturer should be consulted for a recommendation if you are in doubt.

In larger diameter blastholes, cast primers are predominately used, although some operators prefer to use cartridge high explosives. Ideally, the primer should fill the diameter of the blasthole as nearly as possible. However, primers are relatively expensive in comparison to the blasting agents used in larger boreholes, so economics are a factor in primer choice.

All blasting agents are subject to transient detonation veloci-



Figure 48.—Highly aluminized AN-FO booster. (Courtesy Gulf Oil Chemicals Co.)

ties (4, 6). That is, they may begin detonating at a relatively low velocity at the point of initiation, with the velocity rapidly building up until the blasting agent reaches its stable velocity, called the steady state velocity. This buildup occurs within about three charge diameters. A low initial velocity probably causes some loss of energy at the primer location. Low initial velocities can result when the primer is too small or of inadequate strength, or when the blasting agent is poorly mixed or partially desensitized by water.

In large-diameter slurry columns, a 1-lb cast primer or a cartridge of gelatin dynamite is often an adequate primer. In AN-FO columns where conditions are dependably dry, a 1-lb primer is sometimes adequate. However, where dampness exists, or where low transient velocities are a particular concern, it is recommended that a 25- or 50-lb charge of high-energy slurry or aluminized AN-FO be poured around the primer. This is called combination priming. High detonation pressure slurries (12-13) and highly aluminized products (9) have been recommended as combination primers (fig. 48). Bureau of Mines research (4) indicates that each type of product does a good job of raising the velocity in the transient zone. An added benefit of combination priming is the margin of safety in damp boreholes that may partially desensitize AN-FO.

Cast primers have been developed which incorporate an internal millisecond delay. The cast primers and the delay devices are supplied separately, with directions for assembly (fig. 12). These delay primers are slipped onto a detonating cord downline and are especially useful in providing multiple delays in the blasthole on a single downline.

### PRIMER MAKEUP

Proper care and technique in making primers is very important because this is the time in the blasting process at which the sensitive initiator and the powerful explosive cartridge are first combined. Because of the additional hazard involved, primers should be made up as close to the blast site as practical and immediately before loading.

In large tunnel projects, it is generally agreed that an outside primer makeup facility is best, assuming that transportation from the facility to the working face is safeguarded. Primers should be dismantled before removal from the blasting site. An adequate hole must be punched into the cartridge to insure the detonator can be fully imbedded. Care must be taken to assure that the detonator does not come out of the primer cartridge during loading. The primer cartridge should never be tamped or dropped down the borehole. One or more cartridges or a few feet of AN-FO should be placed above the primer cartridge before dropping or tamping begins.

In small-diameter holes, it is especially important that the end of the cap points in the direction of the main charge. It is also strongly recommended in small-diameter holes that the primer cartridge be the first cartridge placed into the blasthole. When priming small-diameter cartridges, the hole for the detonator is usually punched in the end of the cartridge. With electric caps, the wires are usually half hitched around the cartridge (fig. 49). Two half hitches are commonly used. The tubes or fuse from nonelectric detonators are not half hitched. It is recommended that the tubes or fuse be taped to the cartridge to assure that the cap is not pulled out during loading.

Some safety fuse will not stand the sharp bend required for end priming. In this case, a diagonal hole is punched all the way through the cartridge and a second diagonal hole is punched partially through. The cap and fuse is strung through

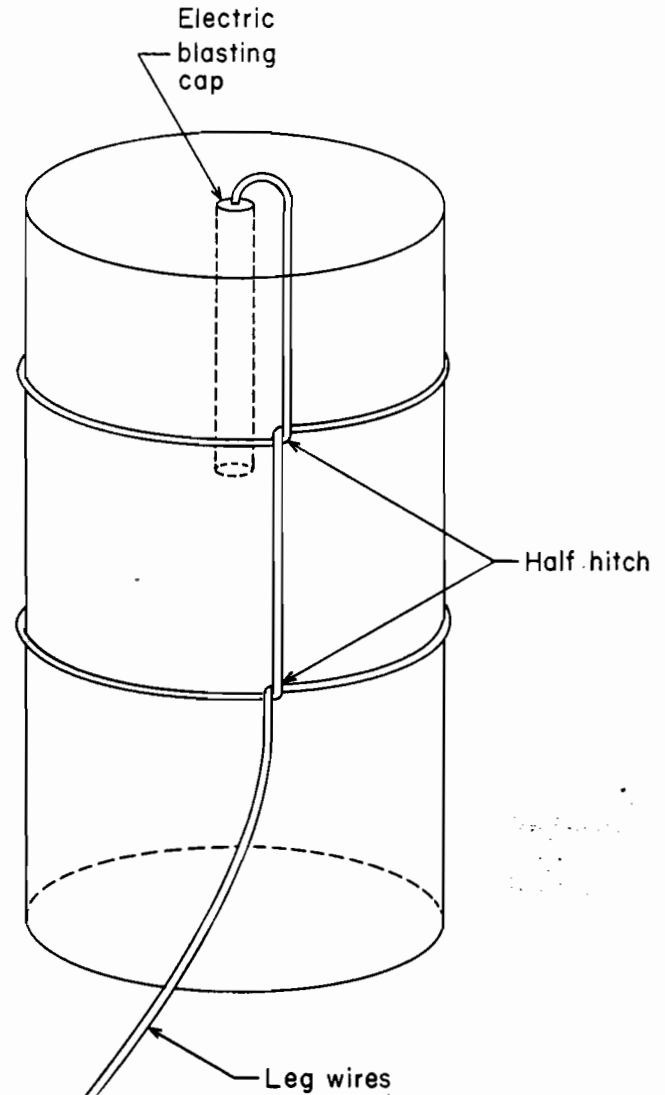

Figure 49.—Cartridge primed with electric blasting cap.

the first hole, placed into the second hole, and pulled secure. Here again, taping of the fuse to the cartridge will assure that the cap is not pulled out during loading.

When attaching detonating cord directly to the small-diameter primer cartridge, the detonating cord is usually inserted into a deep axial hole in the end of the cartridge. The cord is then either taped to the cartridge, passed through a diagonal hole in the cartridge, or secured with a half hitch to assure that the cord will not pull out.

When priming large-diameter cartridges with electric blasting caps, a diagonal hole is punched from the top center of the cartridge and out the side about 8 in from the top. The cap wires are doubled over, threaded through the hole, and wrapped around the cartridge. The cap is placed into a hole punched into the top of the cartridge and the assembly is pulled tight. Tape may be used for extra security.

Detonating cord is secured to large-diameter cartridges by punching a diametrical hole through the cartridge, passing the cord through the cartridge, and tying the cord at the top of the cartridge with a secure knot. This should not be done when using non-water-resistant explosive products in wet boreholes

because the cartridge may become desensitized by water entering the punched hole. Cap and fuse is not commonly used with large cartridges. With other nonelectric initiators, it is recommended that cast primers rather than large-diameter explosive cartridges be used.

Cast primers (fig. 11) are most commonly used to prime large-diameter blastholes. For use with detonating cord, a cast primer with a single axial hole is used. The cord is passed through the cord "tunnel" and tightly knotted at the bottom of the primer. Since this knot will not pull back through the tunnel it is not necessary to tie the cord around the primer. Subsequent primers can be added wherever desired by passing the downline at the blasthole collar through the primer tunnel and sliding the primer down the downline. Placement of delay cast primers on the downline is done in a similar fashion except that the tunnel for the cord is connected to the perimeter of the primer rather than passing through the center of the primer itself.

Cast primers for use with detonators have a cap well in addition to a tunnel. The cap is inserted through the tunnel and back up into the well, making sure that the cap is seated in the bottom of the well (fig. 50). Although the cap will usually stay securely in the primer using this type of configuration, it is a good idea to use a wrap of tape around the end containing the

cap well for security. Remember that not all cast primers have tunnels large enough to accept the Hercudet duplex tubing.

### PRIMER LOCATION

Proper location of the primer is important from the standpoint of both safety and efficiency (7, 6). When using cartridge products in small-diameter blastholes, the primer should be the first cartridge placed into the hole, with the cap pointing toward the collar. This assures maximum confinement and the most efficient use of the explosive's energy. Placing the primer in the bottom minimizes bootlegs and also protects against leaving undetonated explosives in the bottom of the hole if the cartridges become separated. The primer cartridge must not be cut, deformed, or tamped. If bulk products are being loaded, the primer may be raised slightly from the bottom of the hole.

In bench blasting with a bulk loaded product, where subdrilling is used, the primer should be placed at toe level, rather than in the bottom of the hole, to reduce ground vibrations. If there is some compelling reason to place the primer at the collar of the hole the detonator should be pointed toward the bottom of the hole.



Figure 50.—Priming cast primer with electric blasting cap. (Courtesy Austin Powder Co.)

In large-diameter blastholes, the location of the primer is more a matter of choice, although bottom initiation is recommended to maximize confinement of the charge. To help reduce vibrations, the primer should be at toe level rather than in the bottom of the hole, where subdrilling is used. Bottom-initiated holes tend to produce less flyrock and airblast than top-initiated holes, assuming that all other blast dimensions are equal. If pulling the toe is not a significant problem, some operators prefer to place the primer near the center of the charge. This gives the quickest total reaction of the explosive column and may yield improved fragmentation. Top priming is seldom recommended except where the only fragmentation difficulty is a hard band of rock in the upper portion of the bench. A rule of thumb, when using a single primer in a large-diameter blasthole, is to place the primer in the zone of most difficult breakage. This will normally be the toe area. Figure 51 summarizes some desirable and undesirable locations for primers in large-diameter blastholes.

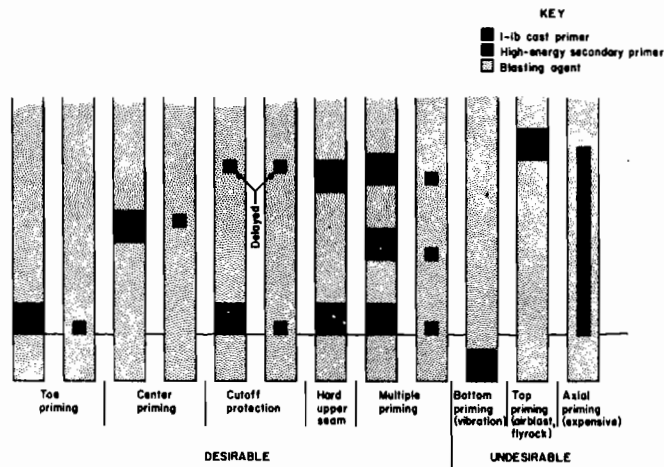

Figure 51.—Priming blasting agents in large-diameter blastholes.

## MULTIPLE PRIMING

In many blasting situations, single-point priming may be adequate. However, there are some situations in which multiple primers in a single borehole may be needed. The first is where deck charges are used. Deck charges are used (1) to reduce the powder factor in a blast while still maintaining satisfactory powder distribution, (2) to break up boulder-prone caprock in the stemming area of the blast, or (3) to reduce the charge weight per delay to reduce vibrations. In situation 3, each deck in the hole is on a different delay period. In 1 and 2, the decks within a single hole may be on the same or on different delays. In any case, each deck charge requires a separate primer. Some States, such as Pennsylvania, require at least two primers per blasthole.

The second reason for multiple priming is as a safety factor to assure total column detonation. With modern explosives and blasting agents, once detonation has been established it will proceed efficiently through the entire powder column. However, an offset in the powder column (fig. 34) may occur before detonation and cause part of the column not to propagate. This is most likely to occur with very long, thin charges or where slip planes are present in the burden area. In these cases, two or more primers should be spaced throughout the powder column. Frequently, these primers will be on the same delay. Where single point priming is preferred, but one or more additional primers are needed to assure total column propagation, the additional primers are put on a later delay period.

With multiple delayed decks in a blasthole, detonation should proceed from the bottom up where a good free face exists. Where the shot is tight, such as in area coal mining, detonation from the top down will give some relief to the lower decks.

Axial priming, which employs a central core of primer throughout an AN-FO column, has been used successfully but appears to have no particular advantage over single point or multiple point priming. Axial priming is more expensive than conventional priming.

## REFERENCES

1. Ash, R. L. The Mechanics of Rock Breakage, Parts I, II, III, and IV. Pit and Quarry, v. 56, No. 2, August 1963, pp. 98-112; No. 3, September 1963, pp. 118-123; No. 4, October 1963, pp. 126-131; No. 5, November 1963, pp. 109-111, 114-118.
2. Atlas Powder Co. (Dallas, TX). Handbook of Electric Blasting. Rev. 1976, 93 pp.
3. Chironis, N. P. New Blasting Machine Permits Custom-Programmed Blast Patterns. Coal Age, v. 79, No. 3, March 1974, pp. 78-82.
4. Condon, J. L., and J. J. Snodgrass. Effects of Primer Type and Borehole Diameter on AN-FO Detonation Velocities. Min. Cong. J., v. 60, No. 6, June 1974, pp. 46-47, 50-52.
5. Dick, R. A. New Nonelectric Explosive Initiation Systems. Pit and Quarry, v. 68, No. 9, March 1976, pp. 104-106.
6. \_\_\_\_\_ . Puzzled About Primers for Large Diameter AN-FO Charges? Here's Some Help to End the Mystery. Coal Age, v. 81, No. 8, August 1976, pp. 102-107.
7. E. I. du Pont de Nemours & Co., Inc. (Wilmington, DE). Blaster's Handbook. 16th ed., 1978, 494 pp.
8. Ensign Bickford Co. (Simsbury, CN). Primacord Detonating Cord. 9th printing, copyright 1963, 68 pp.
9. Grant, C. H. Metallized Slurry Boosting: What It Is and How It Works. Coal Age, v. 71, No. 4, April 1966, pp. 90-91.
10. Hagan, T. N. Optimum Priming for Ammonium Nitrate Fuel-Oil Type Explosives. Proc. Southern and Central Queensland Conf. of the Australasian Inst. of Min. and Met., Parkville, Australia, July 1974, pp. 283-297; available for consultation at Bureau of Mines Twin Cities Research Center, Minneapolis, MN.
11. Institute of Makers of Explosives Safety Library (Washington, DC). Safety Guide for the Prevention of Radio Frequency Radiation Hazards in the Use of Electric Blasting Caps. Pub. No. 20, October 1978, 20 pp.
12. Junk, N. M. Overburden Blasting Takes on New Dimensions. Coal Age, v. 77, No. 1, January 1972, pp. 92-96.
13. \_\_\_\_\_ . Research on Primers for Blasting Agents. Min. Cong. J., v. 50, No. 4, April 1964, pp. 98-101.
14. Sengupta, D., G. French, M. Heydari, and K. Hanna. The Impact of Eliminating Safety Fuse From Metal/Nonmetal Mines (Contract J0295010. Sci. Applications, Inc.). BuMines OFR 61-81, August 1980, 21 pp.; NTIS PB 81-214386.



## Chapter 3.—BLASTHOLE LOADING

Blasthole loading involves placing all of the necessary ingredients into the blasthole, including the main explosive charge, deck charges, initiation systems, primers, and stemming. Blasthole loading techniques vary depending on borehole diameter, type of explosive, and size of the blast. For the purpose of this discussion, boreholes have been arbitrarily classified as small diameter ( $\leq 4$  in) and large diameter ( $> 4$  in). Small-diameter boreholes may be drilled at practi-

cally any inclination from vertically down to vertically up. Large-diameter blastholes are usually drilled vertically down, but in some cases are angled or horizontal.

As a specific precaution, blastholes should never be loaded during the approach or progress of an electrical storm. General descriptions of blasthole loading procedures are in the literature (2-5).<sup>1</sup>

### CHECKING THE BLASTHOLE

Before loading begins, the blastholes should be checked. Depending on the designed depth, either a weighted tape measure or a tamping pole should be used to check that the boreholes are at the proper depth. If a hole is deeper than the plan calls for, drill cuttings or other stemming material should be used to bring the bottom of the hole up to the proper level. Loading an excessively deep blasthole is a waste of explosive and usually increases ground vibrations. Boreholes that are less than the planned depth should either be cleaned out with the drill or compressed air, or redrilled. Sometimes economics or equipment limitations may dictate that a shot be fired with a few short holes. The blasting foreman should make this decision.

Occasionally a borehole may become obstructed. On a sunny day, a mirror may be used to check for obstructions. Obstructions in small holes may sometimes be dislodged with a tamping pole. In large, vertical holes, a heavy weight suspended on a rope and dropped repeatedly on the obstruction may clear the hole. It may be necessary to use the drill string to clear a difficult obstruction or, if the obstruction cannot be cleared, redrilling may be necessary.

If it is necessary to redrill a hole adjacent to a blocked hole, the blocked hole should be filled with stemming. If this is not done, the new hole may shoot into the blocked hole and vent, causing excessive flyrock, airblast, and poor fragmentation. A hole must not be redrilled where there is a danger of intersecting a loaded hole.

While checking the hole for proper depth, it is convenient to check for water in the borehole. With just a little experience, the blaster can closely estimate the level of water in a borehole by visually checking the tamping pole or weighted tape for wetness after the borehole depth check has been made. To get a more accurate check, the weighted end of the tape can be jiggled up and down at the water level. A splashing sound will indicate when the weight is at the water level.

A blasthole may pass through or bottom into an opening. Where this opening is not unduly large, it may be filled with

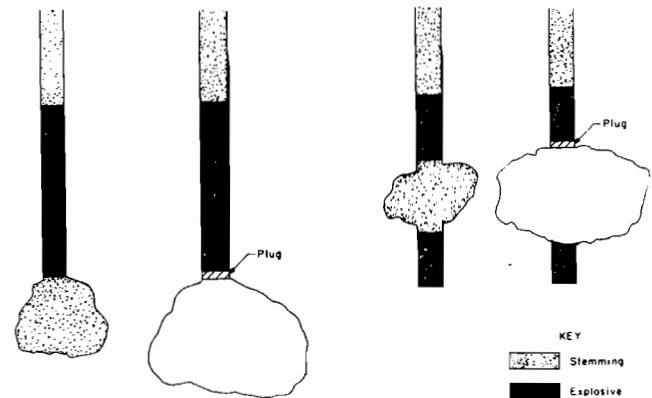

Figure 52.—Corrective measures for voids.

stemming material (fig. 52). Where the opening is too large for this to be practical, the hole must either be left unloaded, redrilled in a nearby location, or plugged.

A simple method for plugging a blasthole is as follows. A stick is tied to the end of a rope, lowered into the void, and pulled back up so it lodges crosswise across the hole. The rope is staked securely at the borehole collar. Bulky materials such as empty powder bags or rags are then dropped down the hole, dirt is then shoveled down the hole to form a solid bottom, after which explosive loading can proceed. Where voids are commonplace, you may want to develop a tailor-made borehole plugging device.

In some districts hot holes may be encountered, although this is not very common. Hot holes may occur in anthracite mining or other areas of in situ coal seam fires. If there is reason to suspect a hot hole, the hole can be checked by suspending a thermometer in it for a few minutes. Explosive materials should not be loaded into holes hotter than 150° F.

### GENERAL LOADING PROCEDURES

Blastholes may be loaded with bulk or packaged products. Bulk products are either poured into the hole, augered, pumped, or blown through a loading hose. Packaged products are either dropped into the hole, pushed in with a tamping pole or other loading device, or loaded through a pneumatic tube. It is

a good idea to check the rise of the powder column frequently as loading progresses, using a tamping pole, weighted tape,

<sup>1</sup>Italicized numbers in parentheses refer to items in the list of references at the end of this chapter.



or loading hose. This will give warning of a cavity or oversized hole that is causing a serious overcharge of explosive to be loaded, and will also assure that sufficient room is left at the top of the hole for the proper amount of stemming. When the powder column has reached the proper location, the primer is loaded into the borehole. It is important that the wires, tubes, or detonating cord leading from the primer are properly secured at the borehole collar in vertical or nearly vertical holes, using a rock or stake.

In almost all situations it is recommended that the explosive charge be totally coupled. Total coupling means that the charge completely fills the borehole diameter. Bulk loading of explosives assures good coupling. When cartridge products are used, coupling is improved by slitting the cartridges and tamping them firmly into place. There are four situations where cartridges or packages of explosives should not be tamped.

1. In permissible coal mine blasting, where deforming the cartridge is against regulations.
2. In controlled blasting, where string loads or even gaps between cartridges are used to reduce the charge load in the perimeter holes to prevent shattering.
3. In water, where the package serves as protection for a non-water-resistant explosive product.
4. A primed cartridge is never tamped.

It is recommended that all blastholes be stemmed to improve the efficiency of the explosive and to reduce airblast and flyrock. As a rule of thumb, the length of stemming should be from 14 to 28 times the borehole diameter. Sized crushed

stone makes the most efficient stemming. However, for reasons of economy and convenience, drill cuttings are most commonly used. Large rocks should never be used as stemming as they could become a dangerous source of flyrock and may also damage the wires, cord, or tubes of the initiation system. Because it is inconvenient to stem horizontal holes, horizontal rounds are sometimes left unstemmed, although it is recommended that all blastholes be stemmed to improve blasting efficiency. By regulation, underground coal mine rounds must be stemmed with noncombustible stemming such as waterfilled cartridges or clay "dummies."

Care must be exercised in using detonating cord downlines in relatively small blastholes. See "Field Application" in the "Detonating Cord Initiation" section of chapter 2 for recommended grain loads of detonating cord as a function of blasthole diameter.

One solution to blasting in wet boreholes is to use a water-resistant explosive. However, economics often favor dewatering the blasthole and loading it with AN-FO inside a protective plastic borehole liner. Although dewatering has been used mostly in large-diameter holes, it can be used in diameters below 4 in. To dewater, a pump is lowered to the bottom of the hole. When the water has been removed, the hole is lined with a plastic sleeve as follows. A roll of hollow plastic tubing is brought to the collar of the hole. A rock is placed inside the end of the tubing and a knot is tied in the end of the tubing to hold the rock in place. The tubing is reeled into the borehole, and care is taken not to tear it. The tubing is cut off at the collar, allowing 4 to 6 ft extra for charge settlement. The AN-FO and primer are loaded inside the tubing and the hole is stemmed. Where water is seeping into the borehole, it is important that the tubing and AN-FO be loaded quickly to prevent the hole from refilling with water.

## SMALL-DIAMETER BLASTHOLES

When small-diameter blastholes are loaded, the primer cartridge is normally loaded at the bottom of the hole. This gives maximum confinement at the point of initiation and also guards against leaving undetonated explosive in the bottom of the borehole if it should become plugged during loading or cut off during the blasting process. Some experts condone, or even recommend a cushion stick or two, but the general recommendation is not to use a cushion stick. To avoid having the detonator fall out of the primer cartridge, the cartridge should never be slit, rolled, or otherwise deformed. The primer cartridge should never be tamped.

### CARTRIDGED PRODUCTS

Cartridged dynamites and slurries (water gels) are commonly used in small-diameter blastholes. These cartridges are usually slit, loaded by hand, and tamped to provide maximum coupling and loading density. One or two cartridges should be loaded after the primer before tamping begins. Tamping should be done firmly, but not excessively. Using the largest diameter cartridge compatible with the borehole diameter will increase coupling and loading density.

Pneumatic systems for loading water gel cartridges are available. The cartridges are propelled through a loading hose at high velocity at a rate of up to one cartridge per second. The cartridges are automatically slit as they enter the blasthole and

each cartridge splits upon impact. Because of the high impact imparted to the cartridges, loading dynamites with this type of loading system is not permitted. Pneumatic cartridge loaders are especially useful in loading holes that have been drilled upward.

### BULK DRY BLASTING AGENTS

Bulk dry blasting agents, usually AN-FO, may be loaded into small-diameter blastholes by pouring from a bag or by pneumatic loading through a loading hose (fig. 53). Poured charges in diameters less than 4 in lose some efficiency because of AN-FO's low density and its reduced detonation velocity at small diameters. As with all bulk loading, good coupling is achieved. Caution should be exercised in using poured AN-FO charges in diameters less than 2 in. This should be done only under bone-dry conditions because AN-FO's efficiency begins to drop significantly at this point, and water will compound the problem.

Pneumatic loading of AN-FO in small holes is recommended because of ease of handling, faster loading rates, and the improved performance of the AN-FO caused by partial pulverizing of the prills, which gives a higher loading density and greater sensitivity (1, 4). The two basic types of pneumatic loading systems are the pressure vessel and the ejector or venturi-type loader.

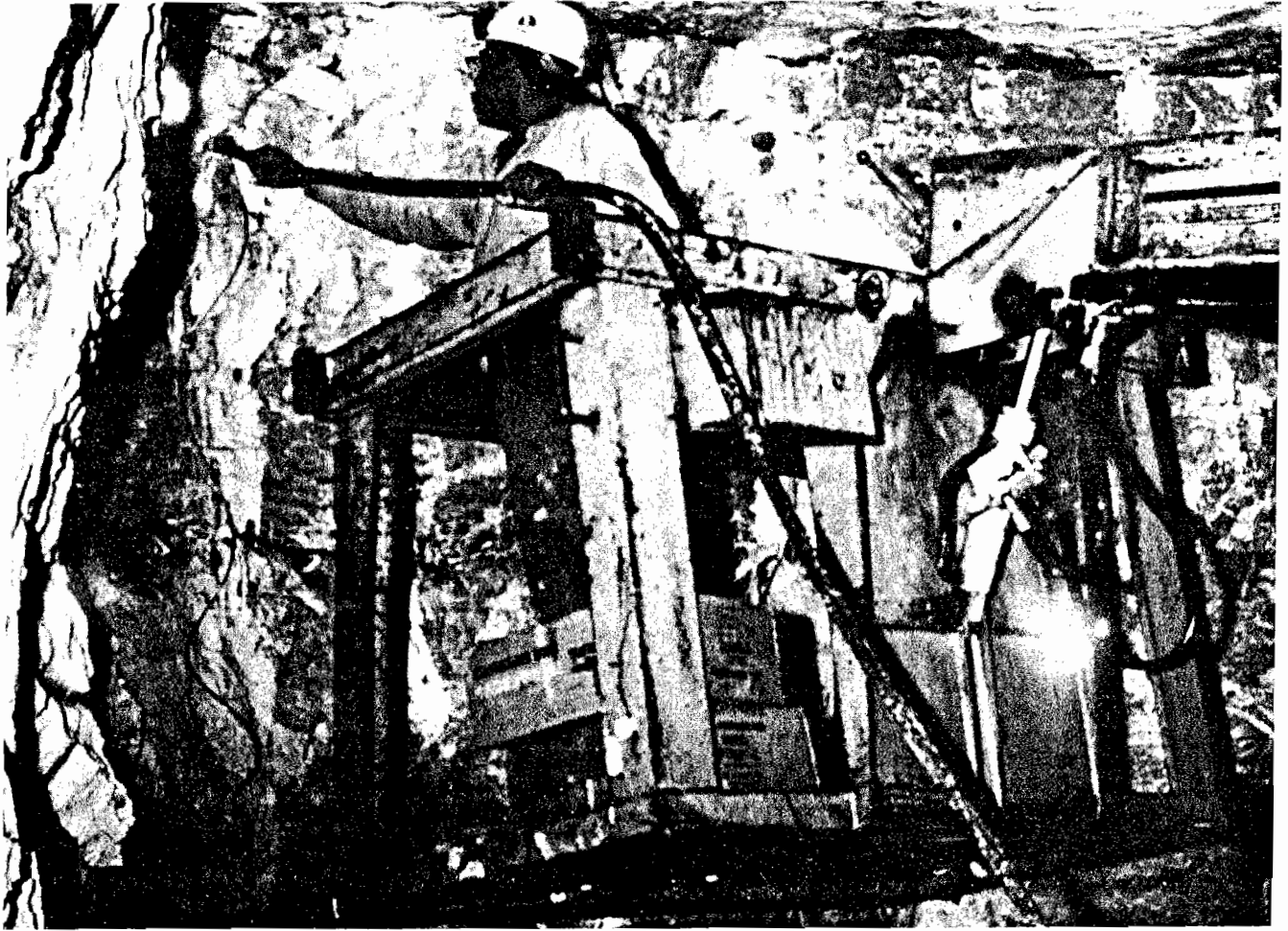

Figure 53.—Pneumatic loading of AN-FO underground. (Courtesy Hercules Inc.)

A pressure vessel type AN-FO loader should have a pressure regulator so that the tank pressure does not exceed the manufacturer's recommendation, usually 30 psi. This low-pressure type loader propels the prills into the borehole at a low velocity and high volume rate, loading the AN-FO at a density slightly above its poured density with a minimum amount of prill breakage. In a pressure vessel, the compartment containing the AN-FO is under pressure during loading. Loading rates of over 100 lb/min can be achieved with some equipment and pressure vessels with AN-FO capacities of 1,000 lb are available. The smaller and more portable pressure vessel loaders have loading rates of 15 to 50 lb/min and AN-FO capacities of 75 to 200 lb. Pressure vessels larger than 1 cu ft in volume should meet ASME specifications for construction.

The ejector-type system (fig. 54) uses the venturi principle to draw AN-FO from the bottom of an open vessel and propel it at a high velocity but low volume rate into the borehole, pulverizing the prills and giving bulk loading densities near 1.00. Ejector systems operate from line pressures of 40 to 80 psi and load at rates of 7 to 10 lb/min. Combination loaders are available that force feed a venturi from a pressurized pot. This system gives the same high loading density and prill breakage as the straight venturi loader with an increase in loading rate. Specifications of pneumatic loading systems are given in table 3. The detonation velocity of AN-FO as a function of charge

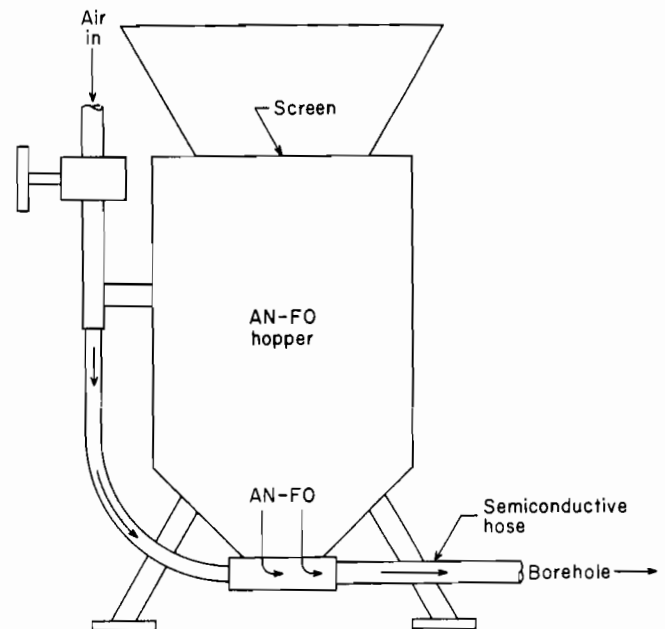

Figure 54.—Ejector-type pneumatic AN-FO loader.

**Table 3 - Characteristics of pneumatically loaded AN-FO in small-diameter blastholes**

Loading device	Tank pressure, psi	Jet pressure, psi	Loading rate, <sup>1</sup> lb/min	Loading density, g/cu cm
Pressure vessel .....	10-30	NAp	15-70	0.80-0.85
Ejector loader (jet) .....	NAp	40-80	7-10	.90-1.00
Combination loader .....	20	20-80	15-25	.90-1.00

NAp Not applicable. <sup>1</sup>Varies with hose diameter.

diameter for poured and pneumatically loaded charges is shown in figure 55. The benefits of high-velocity pneumatic loading are significant at small borehole diameters.

A problem may arise where a high-pressure ejector loader is used to load AN-FO in small holes in soft formations such as uranium ore. The pulverized prills may be dead pressed by the compression from adjacent charges fired on earlier delays. This can cause the AN-FO not to fire.

Static electricity can be a hazard when loading AN-FO pneumatically into small-diameter boreholes. Static electricity hazards can be reduced by using antistatic caps or nonelectric initiators such as Hercudet,<sup>2</sup> Nonel, or Detaline. A semiconductive hose with a minimum resistance of 1,000 ohms/ft and 10,000 ohms total resistance, and a maximum total resistance of 2,000,000 ohms for the entire system, should be used. The pneumatic loader should be properly grounded.

Homemade loading equipment should not be used. All equipment should be operated at the proper pressure. Gaps in the powder column can be avoided by keeping the hopper full and maintaining a constant standoff distance between the end of the loading hose and the column of AN-FO. Loading proficiency improves through operator experience.

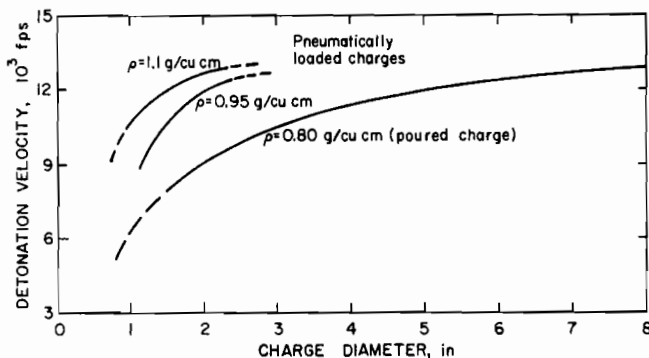

**Figure 55.—AN-FO detonation velocity as a function of charge diameter and density.**

## LARGE-DIAMETER BLASTHOLES

With few exceptions, economics and efficiency favor the use of bulk loading in blasthole diameters larger than 4 in. The products are cheaper, loading is faster, and the well-coupled bulk charge gives better blasting efficiency. As described in the "Priming" section of chapter 2, large-diameter blastholes may be top, center, or toe primed, or multiple primers may be used.

<sup>2</sup>Reference to specific trade names does not imply endorsement by the Bureau of Mines.

The pneumatic loading tube is useful for blowing standing drill water from a horizontal borehole. However, if the borehole is "making water," external protection for the AN-FO by means of a plastic sleeve is required. Loading inside a plastic borehole sleeve is not recommended for underground work because of the static electricity hazard during loading and toxic fumes generated during blasting. If plastic-sleeve protection with pneumatic loading in well-ventilated locations is required, a nonelectric detonating system should be used because the insulating effect of the sleeve is likely to cause a buildup of static electricity.

## BULK SLURRIES

Slurries may be bulk loaded into blasthole diameters as small as 2 in. These products are frequently poured from bags (fig. 56), but occasionally bulk pumping units are used (fig. 57). The sensitivity of slurries, and hence the diameter at which they may be effectively used, depends largely on their formulation. The use of bulk slurries in diameters below those intended for the product can result in substandard blasts or misfires. The manufacturer should be consulted when loading bulk slurries into small-diameter blastholes.

## PERMISSIBLE BLASTING

Loading blastholes in underground coal mines is strictly regulated by MSHA in order to prevent ignition of explosive atmospheres. Only permissible explosives may be used in underground coal mines. Certain nitroglycerin-based explosives, emulsions, slurries, and water gels have been certified as permissible by MSHA (6).

The primer plus the remaining cartridges are stringloaded and pushed back into the hole as a single unit to avoid getting coal dust between the cartridges. Charge weights may not exceed 3 lb per borehole. Black powder, detonating cord, and AN-FO are not permissible. Blastholes are initiated with copper alloy shell electric blasting caps. All holes must be stemmed with noncombustible material such as water bags or clay dummies. The stemming length must be at least 24 in or one-half the depth of the borehole, whichever is less. Additional rules for permissible blasting are given in the "Blast Design" chapter. Permissible blasting procedures are also required for gassy noncoal mines, but are frequently less stringent than for coal mines.

## PACKAGED PRODUCTS

Large-diameter dynamite cartridges are seldom used today except for occasional use as primers. AN-FO and slurries give better economy in large-diameter blastholes. When wet boreholes are encountered, and the operator wants to use AN-FO, water-resistant polyburlap packages of partially pulverized, densified AN-FO are used (fig. 7). Densification is necessary so that the packages will sink in water. AN-FO packages should be carefully lowered into water-filled holes rather than dropped, because a broken bag will result in desensitized AN-FO, an interruption in the powder column and, most likely,



Figure 56.—Pouring slurry into small-diameter borehole. (Courtesy Atlas Powder Co.)

some unfired AN-FO. A disadvantage of waterproof AN-FO packages is that some borehole coupling is lost. Also the heat lost to the water will reduce the energy released. Where it is desired to use AN-FO in wet boreholes, the option of borehole dewatering should be investigated.

Slurries are available in polyethylene packaging in diameters up to 8 in (fig. 10). Some of these products are semirigid and others are in dimensionless bags that will slump to fit the borehole diameter. With the semirigid cartridges, the advantage of borehole coupling is lost.

### BULK DRY BLASTING AGENTS

Bulk loading offers significant advantages over loading of packaged products in large-diameter blastholes, including cheaper products, faster loading, and better use of the available space in the borehole.

The bulk AN-FO or prills are stored in overhead storage bins, from which they are loaded into the bulk trucks. The AN-FO may be trucked to the blast site in premixed form or the oil may be metered into the prills as they are placed into the

blasthole. Bulk loading systems for dry blasting agents (AN-FO) may be of the auger or pneumatic type.

Auger loading gives the fastest loading rates. A side-boom auger is satisfactory for loading one row of holes at a time. Where it is desired to reach more holes from one setup, an overhead-boom auger with a 350° radius of swing can be used. With this type of equipment, flexible tubing usually extends from the end of the auger boom to ground level. The amount of blasting agent delivered into the blasthole is sometimes indicated on a meter in the truck. In other situations a hopper with a given volume of capacity is hung at the end of the auger boom to measure the AN-FO as it is loaded. Bulk loading trucks have capacities of from 2,000 to 30,000 lb of AN-FO, and with auger systems can deliver up to 600 lb of AN-FO per minute into a blasthole.

Pneumatic loading is also used in large-diameter boreholes. Pneumatic units are especially useful in rough terrain, where a long loading hose is used to load numerous blastholes from a single setup.

Hand pouring AN-FO from 50-lb bags is still practiced at operations where the capital expense of a bulk system cannot be justified. This, of course gives the same complete coupling as bulk loading.



Figure 57.—Pumping slurry into small-diameter borehole. (Courtesy Du Pont Co.)

### BULK SLURRIES

Bulk slurry pumping is commonplace in large-diameter vertical-hole blasting. Some slurry trucks have capacities of up to 30,000 lb of slurry and have typical pumping rates of 200 to 400 lb/min. A bulk slurry truck may bring a plant-mixed slurry to the borehole or it may carry separate ingredients for onsite mixing.

Onsite slurry mixing is more complex than AN-FO mixing and is usually done by a competent explosive distributor rather than the consumer. Plant mixing permits closer quality control in the blending of ingredients, whereas onsite mixing permits

different energy densities to be loaded from hole to hole or in different locations within a single hole.

The slurry is pumped as a liquid (fig. 58) and a cross-linking ingredient is added just as the slurry enters the loading hose. Cross linking to a gelatinous consistency begins in the hose and is completed in the borehole. A meter on the bulk truck indicates the amount of slurry that has been loaded.

Hand pouring of slurry from polyethelene packages (fig. 56) is still practiced at operations where the volume of slurry used does not justify a bulk-loading truck. Pouring, rather than loading the entire package, gives complete borehole coupling.



Figure 58.—Slurry leaving end of loading hose. (Courtesy Du Pont Co.)

## REFERENCES

1. Atlas Powder Co. (Dallas, TX). Pneumatic Loading of Nitro-Carbo-Nitrates; Static Electricity, Fumes, and Safe Handling. Undated, 17 pp.
2. Dannenberg, J. How To Solve Blasting Materials Handling Problems. *Rock Products*, v. 74, No. 9, September 1971, pp. 63-65.
3. Dick, H. A. Explosives and Borehole Loading. Subsection 11.7, *SME Mining Engineering Handbook*, ed. by A. B. Cummins and I. A. Given. Society of Mining Engineers of the American Institute of Mining, Metallurgical, and Petroleum Engineers, Inc., New York, v. 1, 1973, pp. 11-78—11-99.
4. E. I. du Pont de Nemours & Co., Inc. (Wilmington, DE). *Blaster's Handbook*. 16th ed., 1978, 494 pp.
5. Langefors, U., and B. A. Kihlstrom. *The Modern Technique of Rock Blasting*. John Wiley & Sons, Inc., New York, 1963, 405 pp.
6. U.S. Mine Enforcement and Safety Administration. Active List of Permissible Explosives and Blasting Devices Approved Before Dec. 31, 1975. MESA Inf. Rep. 1046, 1976, 10 pp.

## Chapter 4.—BLAST DESIGN

Blast design is not a precise science. Because of the widely varying nature of rock, geologic structure, and explosives, it is impossible to set down a series of equations which will enable the blaster to design the ideal blast without some field testing. Tradeoffs must frequently be made in designing the best blast for a given situation. This chapter will describe the fundamental concepts of blast design. These concepts are useful as a first approximation for blast design and also in troubleshooting the cause of a bad blast. Field testing is necessary to refine the individual blast dimensions.

Throughout the blast design process, two overriding princi-

ples must be kept in mind. (1) Explosives function best when there is a free face approximately parallel to the explosive column at the time of detonation and (2) there must be adequate space into which the broken rock can move and expand. Excessive confinement of explosives is the leading cause of poor blasting results such as backbreak, ground vibrations, airblast, unbroken toe, flyrock, and poor fragmentation.

Many of the principles discussed in this section were first presented by Ash (2)<sup>1</sup> and later reported by Puggleise (7) during a study of quarrying practices in this country.

### PROPERTIES AND GEOLOGY OF THE ROCK MASS

The character of the rock mass is a critical variable affecting the design and results of a blast. The nature of rock is very qualitative and cannot be quantified numerically. Rock character often varies greatly from one part of a mine to another or from one end of a construction job to another. Decisions on explosive selection, blast design, and delay pattern must take firsthand knowledge of the rock mass into account. For this reason, the onsite blaster usually has a significant advantage over an outside consultant in designing a blast. Although the number of variations in the character of rock is practically infinite, a general discussion of the subject will be helpful. The Bureau has published a report (7) that discusses the effects of geology on blast design.

#### CHARACTERIZING THE ROCK MASS

The keys to characterizing the rock mass are a good geologist and a good driller. The geologist concentrates on obtaining data from the rock surface. Jointing is probably the most significant geologic feature of the rock. The geologist should document the direction, severity, and spacing between the joint sets. In most sedimentary rocks there are at least three joint sets, one dominant and two less severe. The strike and dip of bedding planes are also documented by the geologist. The presence of major zones of weakness such as faults, open beds, solution cavities, or zones of incompetent rock or unconsolidated material are also determined. Samples of freshly broken rock can be used to determine the hardness and density of the rock.

An observant driller can be of great help in assessing rock variations that are not apparent from the surface. Slow penetration and excessive drill noise and vibration indicate a hard rock that will be difficult to break. Fast penetration and a quiet drill indicate a softer, more easily broken zone of rock. Total lack of resistance to penetration, accompanied by a lack of cuttings or return water or air, means that the drill has hit a void zone. Lack of cuttings or return water may also indicate the presence of an open bedding plane or other crack. A detailed drill log indicating the depth at which these various conditions exist can be very helpful to the person designing the blast. The driller should also document changes in the color or nature of the drill cuttings, which will tell the blaster the location of various beds in the formation.

#### ROCK DENSITY AND HARDNESS

Some amount of displacement is required to prepare a muckpile for efficient excavation. The density of the rock is a major factor in determining how much explosive is needed to displace a given volume of rock (powder factor). The burden-to-charge diameter ratio, which will be discussed in the next section, "Surface Blasting," varies with rock density, causing the change in powder factor. The average burden-to-charge-diameter ratio of 25 to 30 is for average density rocks such as limestone (2.5 to 2.8 g/cu cm), schist (2.6 to 2.8 g/cu cm), or porphyry (2.5 to 2.6 g/cu cm). Denser rocks such as basalt (2.9 g/cu cm) and magnetite (4.9 to 5.2 g/cu cm) require smaller ratios (higher powder factors). Lighter materials such as some sandstones (2.0 to 2.6 g/cu cm) or bituminous coal (1.2 to 1.5 g/cu cm) can be blasted with higher ratios (lower powder factors).

The hardness or brittleness of rock can have a strong effect on blasting results. Soft rock is much more "forgiving" than hard rock. If soft rock is slightly underblasted, it will probably still be diggable. If soft rock is slightly overblasted, excessive violence will not usually occur. On the other hand, slight underblasting of hard rock will often result in a tight muckpile that is difficult to dig. Overblasting of hard rock is likely to cause excessive flyrock and airblast. Blast designs for hard rock, then, require closer control and tighter tolerances than those for soft rock.

#### VOIDS AND INCOMPETENT ZONES

Unforeseen voids and zones of weakness such as solution cavities, underground workings, mud seams, and faults are serious problems in blasting. Explosive energy always seeks the path of least resistance (fig. 59). Where the rock burden is composed of alternate zones of hard material and incompetent material or voids, the explosive energy will be vented through the incompetent zones, resulting in poor fragmentation. Depending on the orientation of the zones of weakness with respect to free faces, excessive violence in the form of airblast

<sup>1</sup>Italicized numbers in parentheses refer to items in the list of references at the end of this chapter.



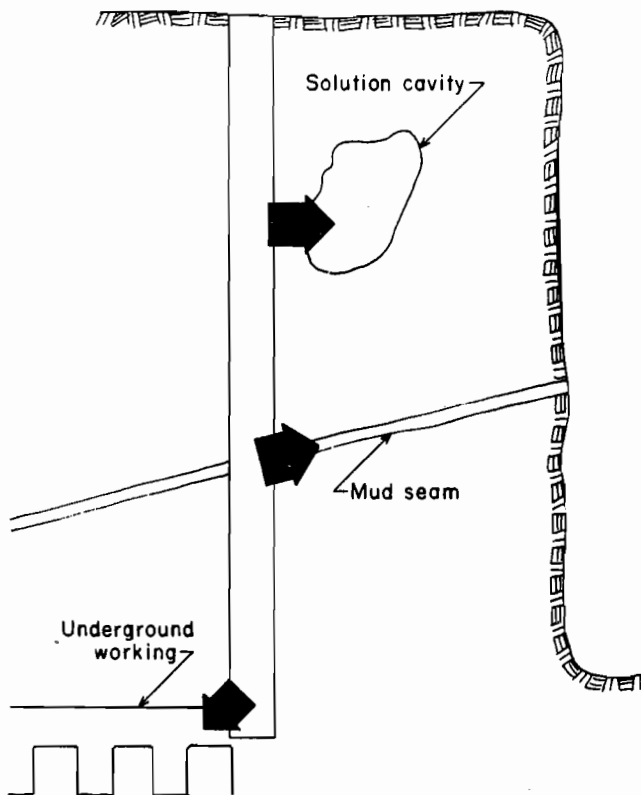

Figure 59.—Loss of explosive energy through zones of weakness.

and flyrock may occur. A particular problem occurs when the blasthole intersects a void zone. In this situation, unless particular care is taken in loading the charge, the void will be loaded with a heavy concentration of explosive, resulting in excessive airblast and flyrock.

If these voids and zones of weakness can be identified, steps can be taken during borehole loading to improve fragmentation and avoid violence. The best tool for this is a good drill log. The depths of voids and incompetent zones encountered by the drill should be documented. The geologist can help by plotting the trends of mud seams and faults. When charging the blasthole, inert stemming material, rather than explosives, should be loaded through these weak zones. Voids should be filled with stemming (fig. 52). Where this is impractical because of the size of the void, it may be necessary to block the hole just above the void before continuing the explosive column, as described in the "Checking the Blasthole" section of chapter 3.

Where the condition of the borehole is in doubt, the rise of the powder column should be checked frequently as loading proceeds. If the column fails to rise as expected, there is probably a void. At this point a deck of inert stemming material should be loaded before powder loading continues. If the column rises more rapidly than expected, frequent checking will assure that adequate space is left for stemming.

Alternate zones of competent and incompetent rock usually result in unacceptably blocky fragmentation. A higher powder factor will seldom correct this problem; it will merely cause the blocks to be displaced farther. Usually the best way to alleviate this situation is to use smaller blastholes with smaller blast pattern dimensions to get a better powder distribution. The explosive charges should be concentrated in the competent rock, with the incompetent zones being stemmed through wherever possible.

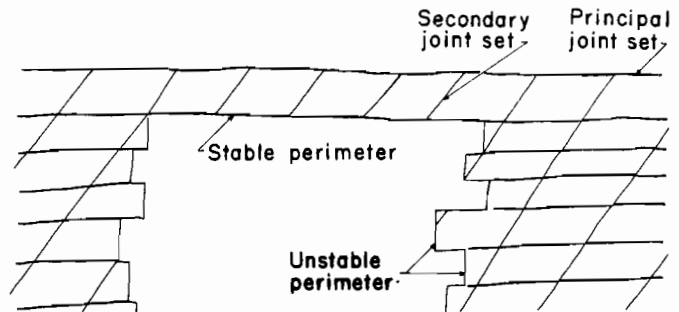

Figure 60.—Effect of jointing on the stability of an excavation.

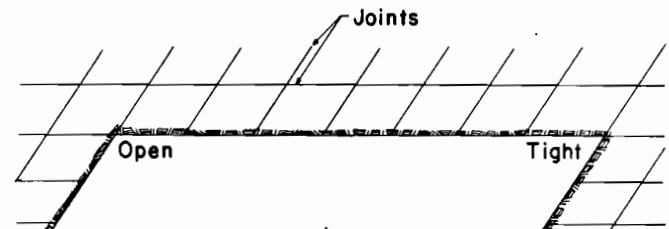

Figure 61.—Tight and open corners caused by jointing.

## JOINTING

Jointing can have a pronounced effect on both fragmentation and the stability of the excavation. Close jointing usually results in good fragmentation. However, widely spaced jointing, especially where the jointing is pronounced, often results in a very blocky muckpile because the joint planes tend to isolate large blocks in place. Where the fragmentation is unacceptable, the best solution is to use smaller blastholes with smaller blast pattern dimensions. This extra drilling and blasting expense will be more than justified by the savings in loading, hauling, and crushing costs and the savings in secondary blasting.

Where possible, the perimeter holes of a blast should be aligned with the principal joint sets. This will tend to produce a more stable excavation, whereas rows of holes perpendicular to a primary joint set will tend to produce a more ragged, unstable perimeter (fig. 60). Jointing will often determine how the corners at the back of the blast will break out. To minimize backbreak and violence, tight corners, shown in figure 61, should be avoided. The open corner at the left of the figure is preferable. Given the predominant jointing in figure 61, more stable conditions will result if the first blast is opened at the far right and is designed so that the hole in the rear inside corner contains the highest numbered delay.

## BEDDING

Bedding can also have an effect on both the fragmentation and the stability of the excavation perimeter. Open bedding planes or beds of weak material should be treated as zones of weakness. Stemming, rather than explosive, should be loaded into the borehole at the location of these zones as shown in figure 62. In a bed of hard material, it is often beneficial to load an explosive of higher density than is used in the remainder of the borehole. To break an isolated bed of hard material near the collar of the blasthole, a deck charge is recommended, as shown in figure 63, with the deck being fired on the same delay as the main charge or one delay later. Occasionally, satellite

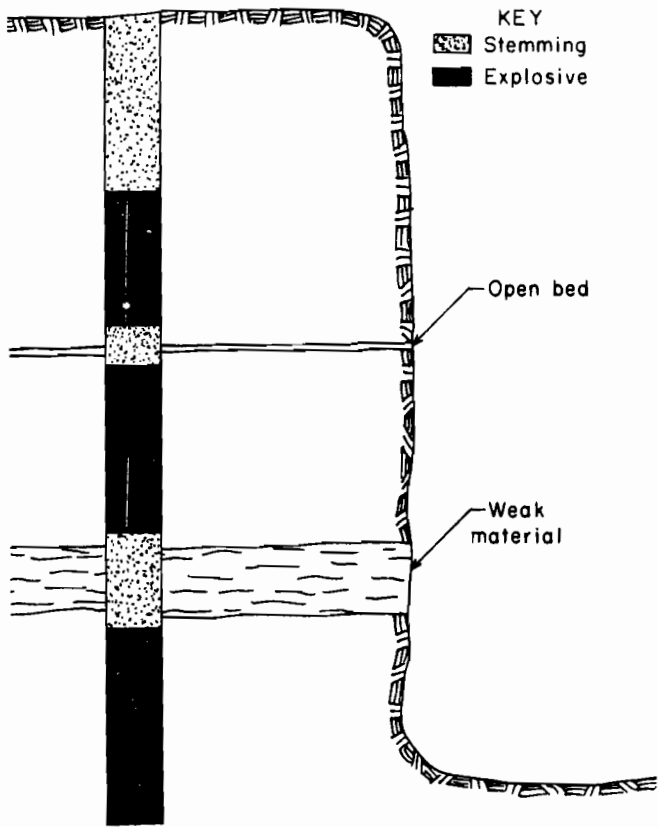

Figure 62.—Stemming through weak material and open beds.

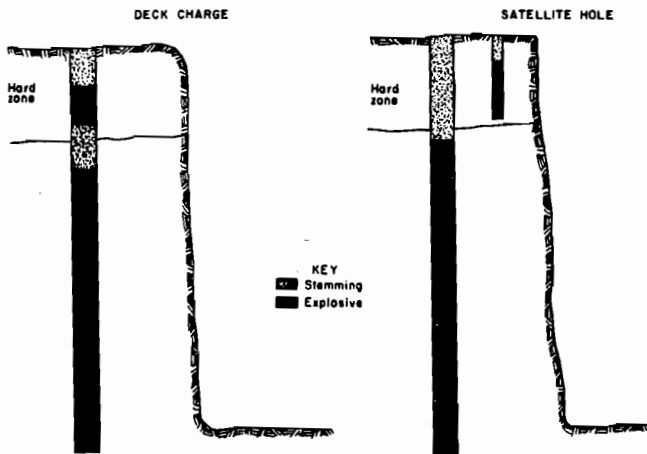

Figure 63.—Two methods of breaking a hard collar zone.

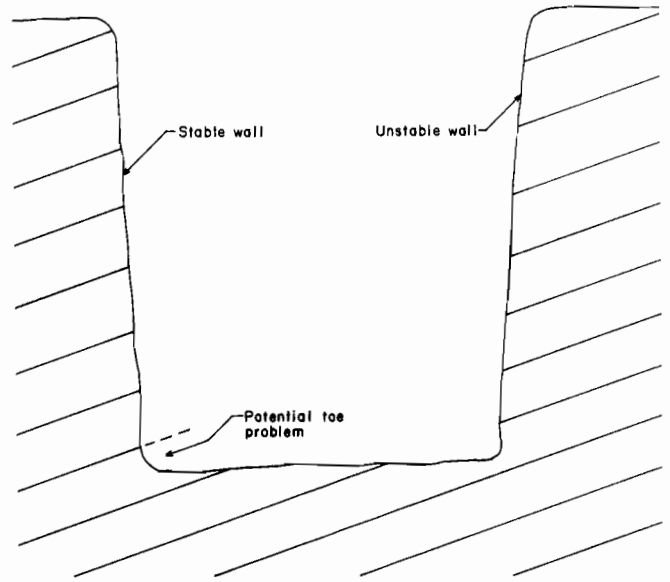

Figure 64.—Effect of dipping beds on slope stability and potential toe problems.

holes are used to help break a hard zone in the upper part of the burden. Satellite holes are short holes, usually smaller in diameter than the main blastholes, which are drilled between the main blastholes.

A pronounced bedding plane is frequently a convenient location for the floor of the bench. It not only gives a smoother floor but also may reduce subdrilling requirements.

Dipping beds frequently cause stability problems and difficulty in breaking the toe of the burden. When the beds dip into the excavation wall, the stability of the slope is enhanced (fig. 64). However, when beds dip outward from the wall they form slip planes that increase the likelihood of slope deterioration. Blasthole cutoffs caused by differential bed movement are also more likely. Beds dipping outward from the final slope should be avoided wherever possible.

Although beds dipping into the face improve slope stability, they do create toe problems (fig. 64), as the toe material tends to break out along the bedding planes. Dipping beds such as these require a tradeoff. Which is the more serious problem in the job at hand, a somewhat unstable slope or an uneven toe? In some cases advancing the opening perpendicular to the dipping beds may be a good compromise.

Many blasting jobs encounter site-specific geologic conditions not covered in this general discussion. A good explosives engineer is constantly studying the geology of the rock mass and making every effort to use the geology to his or her advantage, or at least to minimize its unfavorable effects.

## SURFACE BLASTING

### BLASTHOLE DIAMETER

The size of blasthole is the first consideration of any blast design. The blasthole diameter, along with the type of explosive being used and the type of rock being blasted, will deter-

mine the burden. All other blast dimensions are a function of the burden. This discussion assumes that the blaster has the freedom to select the borehole size. In many operations one is limited to a specific size borehole based on available drilling equipment.

Practical blasthole diameters for surface mining range from

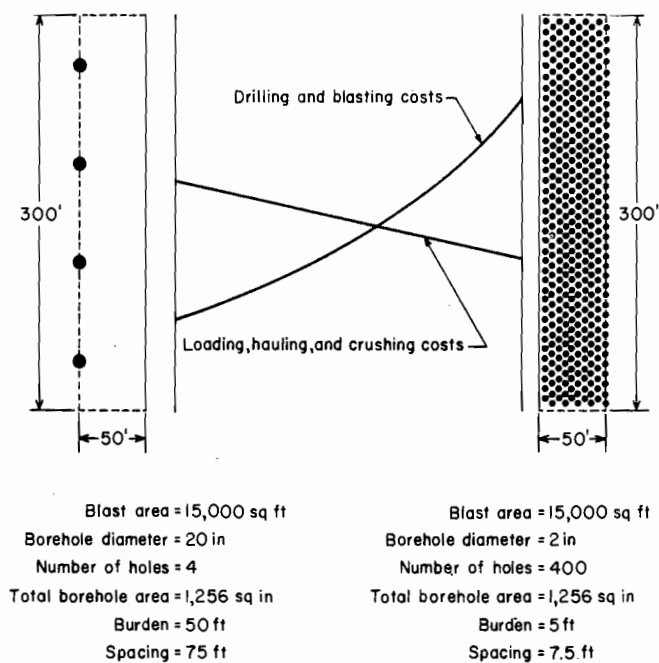

**Figure 65.—Effect of large and small blastholes on unit costs.**

2 to 17 in. As a general rule, large blasthole diameters yield low drilling and blasting costs because large holes are cheaper to drill per unit volume and less sensitive, cheaper blasting agents can be used in larger diameters. However, larger diameter blastholes also result in large burdens and spacings and collar distances and hence, they tend to give coarser fragmentation. Figure 65 (3) illustrates this comparison using 2- and 20-in-diameter blastholes as an example. Pattern A contains four 20-in blastholes and pattern B contains 400 2-in blastholes. In all bench blasting operations some compromise between these two extremes is chosen. Each pattern represents the same area of excavation, 15,000 sq ft, each involves approximately the same volume of blastholes, and each can be loaded with about the same weight of explosive.

In a given rock formation, the four-hole pattern will give relatively low drilling and blasting costs. Drilling costs for the large blastholes will be low, a low-cost blasting agent will be used, and the cost of detonators will be minimal. However, in a difficult blasting situation, the broken material will be blocky and nonuniform in size, resulting in higher loading, hauling, and crushing costs as well as requiring more secondary breakage. Insufficient breakage at the toe may also result.

On the other hand, the 400-hole pattern will yield high drilling and blasting costs. Small holes cost more to drill per unit volume, powder for small-diameter blastholes is usually more expensive, and the cost of detonators will be higher. However, the fragmentation will be finer and more uniform, resulting in lower loading, hauling, and crushing costs. Secondary blasting and toe problems will be minimized. Size of equipment, subsequent processing required for the blasted material, and economics will dictate the type of fragmentation needed, and hence the size of blasthole to be used.

Geologic structure is a major factor in determining blasthole diameter. Planes of weakness such as joints and beds, or zones of soft, incompetent rock tend to isolate large blocks of rock in the burden. The larger the blast pattern, the more likely these blocks are to be thrown unbroken into the muckpile.

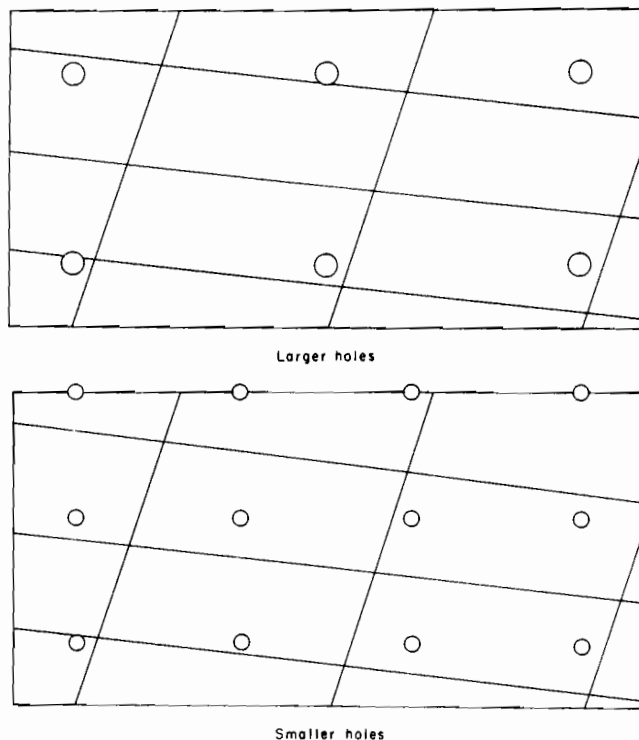

**Figure 66.—Effect of jointing on selection of blast-hole size.**

Note that in the top pattern in figure 66 some of the blocks are not penetrated by a blasthole, whereas in the smaller bottom pattern all of the blocks contain at least one blasthole. Owing to the better explosives distribution, the bottom pattern will give better fragmentation.

As more blasting operations are carried out near populated areas, environmental problems such as airblast and flyrock often occur because of an insufficient collar distance above the explosive charge. As the blasthole diameter increases, the collar distance required to prevent violence increases. The ratio of collar distance to blasthole diameter required to prevent violence varies from 14:1 to 28:1, depending on the relative densities and velocities of the explosive and rock, the physical condition of the rock, the type of stemming used, and the point of initiation. A larger collar distance is required where the sonic velocity of the rock exceeds the detonation velocity of the explosive or where the rock is heavily fractured or low in density. A top-initiated charge requires a larger collar distance than a bottom-initiated charge. As the collar distance increases, the powder distribution becomes poorer resulting in poorer fragmentation of the rock in the upper part of the bench.

Ground vibrations are controlled by reducing the weight of explosive fired per delay interval. This is more easily done with small blastholes than with large blastholes. In many situations where an operator uses large-diameter blastholes near populated areas, several delayed decks must be used within each hole to control vibrations.

Large holes with large blast patterns are ideally suited to an operation with the following characteristics: A large volume of material to be moved; large loading, hauling, and crushing equipment; no requirement for fine, uniform fragmentation; an easily broken toe; few ground vibration or airblast problems (few nearby neighbors); and a relatively homogeneous, easily fragmented rock without excessive, widely spaced planes of

weakness or voids. Many blasting jobs, however, present constraints that require smaller blastholes.

In the final analysis, the selection of blasthole size is based on economics. It is important to consider the economics of the overall excavation or mining system. Savings realized through indiscriminate cost cutting in the drilling and blasting program may well be lost through increased loading, hauling, and crushing costs and increased litigation costs owing to disgruntled neighbors.

### TYPES OF BLAST PATTERNS

There are three commonly used drill patterns; square, rectangular, and staggered. The square drill pattern (fig. 67) has equal burdens and spacings, while the rectangular pattern has a larger spacing than burden. In both the square and rectangular patterns, the holes of each row are lined up directly behind the holes in the preceding row. In the staggered pattern (fig. 67), the holes in each row are positioned in the middle of the spacings of the holes in the preceding row. In the staggered pattern, the spacing should be larger than the burden.

The staggered drilling pattern is used for row-on-row firing; that is, where the holes of one row are fired before the holes in the row immediately behind them as shown in figure 68. The square or rectangular drilling patterns are used for firing V-cut (fig. 69) or echelon rounds. Either side of the blast round in figure 69 by itself would be called an echelon blast round. In V-cut or echelon blast rounds the burdens and subsequent rock displacement are at an angle to the original free face. Looking at figure 69, with the burdens developed at a 45° angle with the original free face, you can see that the originally square drilling pattern has been transformed to a staggered blasting pattern with a spacing twice the burden. The simple patterns discussed here account for the vast majority of the surface blasts fired.

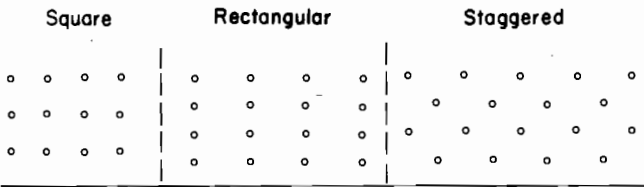

Figure 67.—Three basic types of drill pattern.



Figure 68.—Corner cut staggered blast pattern—Simultaneous initiation within rows (blasthole spacing, S, is twice the burden, B).

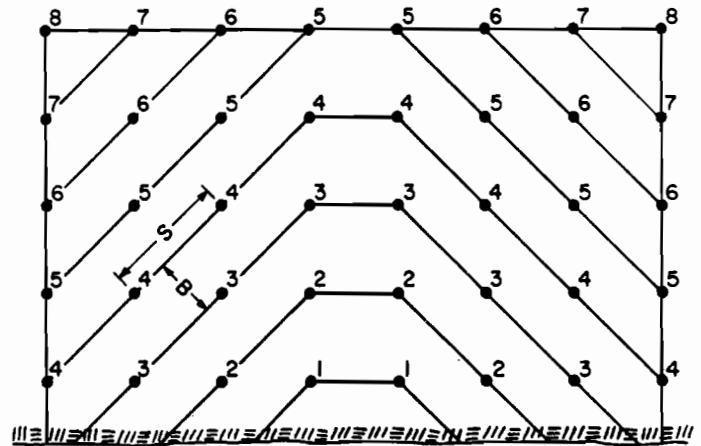

Figure 69.—V-echelon blast round (true spacing, S, is twice the true burden, B).

### BURDEN

Figure 70 is an isometric view showing the relationship of the various dimensions of a bench blast. The burden is defined as the distance from a blasthole to the nearest free face at the instant of detonation. In multiple row blasts, the burden for a blasthole is not necessarily measured in the direction of the original free face. One must take into account the free faces developed by blastholes fired on lower delay periods. As an example, in figure 68, where one entire row is blasted before the next row begins, the burden is measured in a perpendicular direction between rows. However, in figure 69 the blast progresses in a V-shape. In this situation, the true burden on most of the holes is measured at an angle of 45° from the original free face, as shown in the figure.

It is very important that the proper burden be calculated, taking into account the blasthole diameter, the relative density

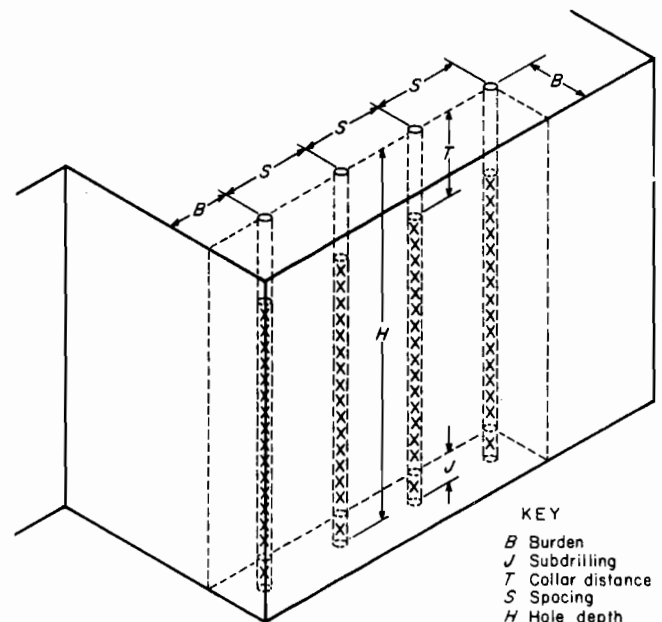

Figure 70.—Isometric view of a bench blast.

of the rock and the explosive, and to some degree, the length of the blasthole. An insufficient burden will cause excessive airblast and flyrock. Too large a burden will give inadequate fragmentation, toe problems, and excessive ground vibrations. Where it will be necessary to drill a round before the previous round has been excavated, it is important to stake out the first row of the second round before the first round is fired. This will assure a proper burden on the first row of blastholes in the second blast round.

The burden dimension is a function of the charge diameter. For bulk-loaded charges, the charge diameter is equal to the blasthole diameter. For tamped cartridges, the charge diameter will be between the cartridge diameter and the blasthole diameter, depending on the degree of tamping. For untamped cartridges the charge diameter is equal to the cartridge diameter. When blasting with AN-FO or other low density blasting agents with densities near 0.85 g/cu cm, in typical rock with a density near 2.7 g/cu cm, the normal burden is approximately 25 times the charge diameter. When using denser products such as slurries or dynamites, with densities near 1.2 g/cu cm, the normal burden is approximately 30 times the charge diameter. It should be stressed again that these are first approximations, and field testing often results in minor adjustments to these values. The burden-to-charge-diameter ratio is seldom less than 20 or seldom more than 40, even in extreme cases. For instance, when blasting with a low density blasting agent, such as AN-FO, in a dense formation such as iron ore, the desired burden may be about 20 times the charge diameter. When blasting with denser slurries or dynamites in low density formations such as some sandstones or marbles, the burden may approach 40 times the charge diameter. Table 4 summarizes these approximations.

**Table 4. - Approximate B/D ratios for bench blasting**

	Ratio
AN-FO (density—0.85 g/cu cm):	
Light rock (density—2.2 g/cu cm) .....	28
Average rock (density—2.7 g/cu cm) .....	25
Dense rock (density—3.2 g/cu cm) .....	23
Slurry, dynamite (density—1.2 g/cu cm):	
Light rock (density—2.2 g/cu cm) .....	33
Average rock (density—2.7 g/cu cm) .....	30
Dense rock (density—3.2 g/cu cm) .....	27

B Burden    D Charge diameter

High-speed photographs of blasts have shown that flexing of the burden plays an important role in rock fragmentation. A relatively long, slender burden flexes, and thus breaks more easily than a short, stiffer burden. Figure 71 shows the difference between using a 6-in blasthole and a 12¼-in blasthole in a 40-ft bench, with a burden-to-charge-diameter ratio of 30 and appropriate subdrilling and stemming dimensions. Note the inherent stiffness of the burden with the 12¼-in blasthole as compared with the 6-in blasthole. Based on this consideration, lower burden-to-charge-diameter ratios should be used as a first approximation when the blasthole diameter is large in comparison to the bench height. Care must be taken that the burden ratio is not so small as to create violence. Once the burden has been determined, it becomes the basis for calculating subdrilling, collar distance (stemming), and spacing.

**SUBDRILLING**

Subdrilling is the distance drilled below the floor level to assure that the full face of rock is removed. Where there is a

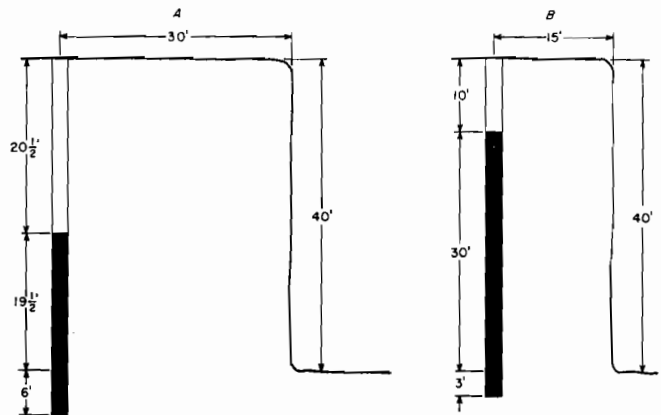

**Figure 71.—Comparison of a 12¼-in-diameter (A) blasthole (stiff burden) with a 6-in-diameter (B) blasthole (flexible burden) in a 40-ft bench.**

pronounced parting at floor level, to which the explosive charge can conveniently break, subdrilling may not be required. In coal stripping, it is common practice to drill down to the coal and then backfill a foot or two before loading explosives, resulting in a negative subdrill. In most surface blasting jobs, however, it is necessary to do some subdrilling to make sure the shot pulls to grade. A good first approximation for subdrilling under average conditions is 30 pct of the burden. Where the toe breaks very easily, the subdrill can sometimes be reduced to 10 to 20 pct of the burden. Even under the most difficult conditions, the subdrill should not exceed 50 pct of the burden. If the toe cannot be pulled with a subdrill-to-burden ratio of 0.5, the fault probably lies in too large a burden.

Priming the explosive column at the toe level gives maximum confinement and normally gives the best breakage. Other factors being equal, toe priming usually requires less subdrilling than collar priming.

Too much subdrilling is a waste of drilling and blasting expense and may also cause excessive ground vibrations owing to the high degree of confinement of the explosive in the bottom of blasthole, particularly when the primer is placed in the bottom of the hole. In multiple-bench operations, excessive subdrilling may cause undue fracturing in the upper portion of the bench below, creating difficulties in collaring holes in the lower bench. Insufficient subdrilling will cause high bottom, resulting in increased wear and tear on equipment and expensive secondary blasting. Table 5 summarizes the recommended subdrilling approximations.

**Table 5. - Approximate J/B ratios for bench blasting**

	Ratio
Open bedding plane at toe.....	0
Easy toe .....	0.1-0.2
Normal toe.....	.3
Difficult toe .....	.4- .5

B Burden    J Subdrilling

**COLLAR DISTANCE (STEMMING)**

Collar distance is the distance from the top of the explosive charge to the collar of the blasthole. This zone is usually filled

with an inert material called stemming to give some confinement to the explosive gases and to reduce airblast. Research has shown that crushed, sized rock works best as stemming but it is common practice to use drill cuttings because of economics. Too small a collar distance results in excessive violence in the form of airblast and flyrock and may cause backbreak. Too large a collar distance creates boulders in the upper part of the bench. The selection of a collar distance is often a tradeoff between fragmentation and the amount of airblast and flyrock that can be tolerated. This is especially true where the upper part of the bench contains rock that is difficult to break. In this situation the difference between a violent shot and one that fails to fragment the upper zone properly may be a matter of only a few feet of stemming. Collar priming of blastholes normally causes more violence than center or toe priming, and requires the use of a longer collar distance.

Field experience has shown that a collar distance equal to 70 pct of the burden is a good first approximation except where collar priming is used. Careful observation of airblast, flyrock, and fragmentation will enable the blaster to further refine this dimension. Where adequate fragmentation in the collar zone cannot be attained while still controlling airblast and flyrock, deck charges or satellite holes may be required (fig. 63).

A deck charge is an explosive charge near the top of the blasthole, separated from the main charge by inert stemming. If boulders are being created in the collar zone but the operator fears that less stemming would cause violence, the main charge should be reduced slightly and a deck charge added. The deck charge is usually shot on the same delay as the main charge or one delay later. Care must be exercised not to place the deck charge too near the top of the blasthole, or excessive flyrock may result. As an alternative, short satellite holes between the main blastholes can be used. These satellite holes are usually smaller in diameter than the main blastholes and are loaded with a light charge of explosives.

From the standpoint of public relations, collar distance is a very important blast design variable. One violent blast can permanently alienate neighbors. In a delicate situation, it may be best to start with a collar distance equal to the burden and gradually reduce this if conditions permit. Collar distances greater than the burden are seldom necessary.

### SPACING

Spacing is defined as the distance between adjacent blastholes, measured perpendicular to the burden. Where the rows are blasted one after the other as in figure 68, the spacing is measured between holes in a row. However, in figure 69, where the blast progresses on an angle to the original free face, the spacing is measured at an angle from the original free face.

Spacing is calculated as a function of the burden and also depends on the timing between holes. Too close a spacing causes crushing and cratering between holes, boulders in the burden, and toe problems. Too wide a spacing causes inadequate fracturing between holes, accompanied by humps on the face and toe problems between holes (fig. 72).

When the holes in a row are initiated on the same delay period, a spacing equal to twice the burden will usually pull the round satisfactorily. Actually, the V-cut round in figure 69 also illustrates simultaneous initiation within a row, with the rows being the angled lines of holes fired on the same delay. The true spacing is twice the true burden even though the holes were originally drilled on a square pattern.

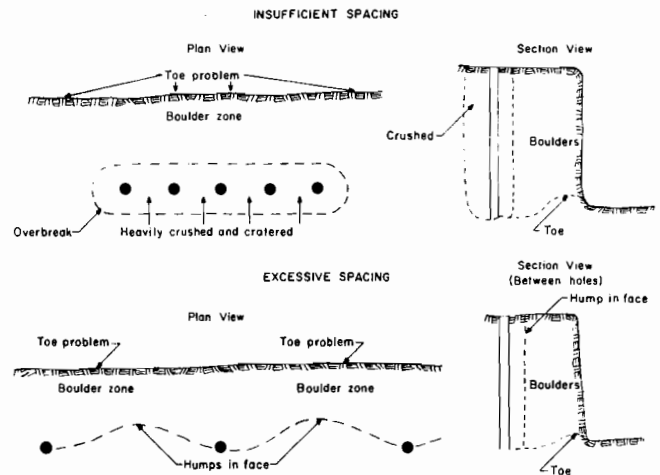

Figure 72.—Effects of insufficient and excessive spacing.

Field experience has shown that the use of millisecond delays between holes in a row results in better fragmentation and also reduces the ground vibrations produced by the blast. When millisecond delays are used between holes in a row, the spacing-to-burden ratio must be reduced to somewhere between 1.2 and 1.8, with 1.5 being a good first approximation. Various delay patterns may be used within the rows, including alternate delays (fig. 73) and progressive delays (fig. 74). Generally, large-diameter blastholes require lower spacing-to-burden ratios (usually 1.2 to 1.5 with millisecond delays) than small-diameter blastholes (usually 1.5 to 1.8). Because of the complexities of geology, the interaction of delays, differences in explosive and

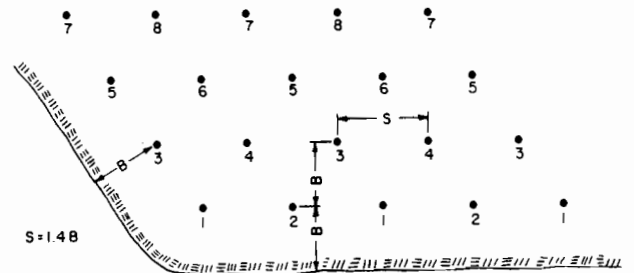

Figure 73.—Staggered blast pattern with alternate delays (spacing, S, is 1.4 times the burden, B).

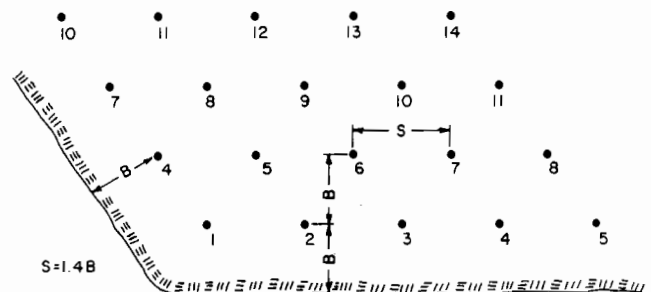

Figure 74.—Staggered blast pattern with progressive delays (spacing, S, is 1.4 times the burden, B).

rock strengths, and other variables, the proper spacing-to-burden ratio must be determined through onsite experimentation, using the preceding values as first approximations.

Except when using controlled blasting techniques such as smooth blasting and cushion blasting, which will be described later in this chapter, the spacing should never be less than the burden.

## HOLE DEPTH

In any blast design it is important that the burden and the blasthole depth (or bench height) be reasonably compatible. As a rule of thumb for bench blasting, the hole depth-to-burden ratio should be between 1.5 and 4.0. Hole depths less than 1.5 times the burden cause excessive airblast and flyrock and, because of the short, thick shape of the burden, give coarse, uneven fragmentation. Where operational conditions require a ratio of less than 1.5, the primer should be placed at the toe of the bench to assure maximum confinement. Keep in mind that placing the primer in the subdrill can cause increased ground vibrations. If an operator continually finds use of a hole depth-to-burden ratio of less than 1.5 necessary, consideration should be given to increasing the bench height or using a smaller drill.

Hole depths greater than four times the burden are also undesirable. The longer a hole is in respect to its diameter the more error there will be in its location at toe level, which is the most critical portion of the blast. A poorly controlled blast will result. Extremely long, slender holes have even been known to intersect.

High benches with short burdens also create hazards, such as a small drill having to put in the front row of holes near the edge of a high ledge or a small shovel having to dig at the toe of a precariously high face. The obvious solution to this problem is to use a lower bench height. There is no real advantage to a high bench height. Lower benches give more efficient blasting results, lower drilling cost and chances for cutoffs, and are safer from an equipment operation standpoint. If it is impractical to reduce the bench height, larger drilling and rock handling equipment should be used, which will effectively reduce the blasthole depth-to-burden ratio.

A major problem with long slender charges is the greater potential for cutoffs in the explosive column. Where it is necessary to use blast designs with large hole depth-to-burden ratios, multiple priming should be used as insurance against cutoffs.

## DELAYS

Millisecond delays are used between charges in a blast round for three reasons:

1. To assure that a proper free face is developed to enable the explosive charge to efficiently fragment and displace its burden.
2. To enhance fragmentation between adjacent holes.
3. To reduce the ground vibrations created by the blast.

There are numerous possible delay patterns, several of which were covered in figures 68, 69, 73, and 74.

Andrews (1), of du Pont, conducted numerous field investigations to determine optimum delay intervals for bench blasting and reached the following conclusions.

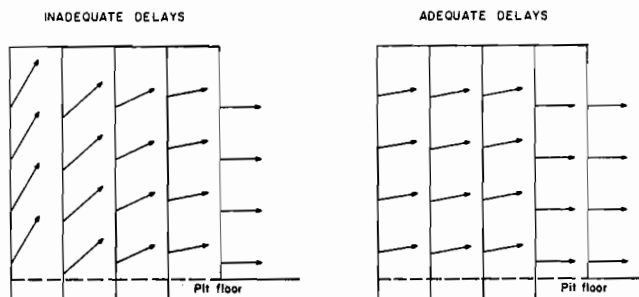

Figure 75.—The effect of inadequate delays between rows.

1. The delay time between holes in a row should be between 1 and 5 ms per foot of burden. Delay times less than 1 ms per foot of burden cause premature shearing between holes, resulting in coarse fragmentation. If an excessive delay time is used between holes, rock movement from the first hole prevents the adjacent hole from creating additional fractures between the two holes. A delay of 3 ms per foot of burden gives good results in many kinds of rock.

2. The delay time between rows should be two to three times the delay time between holes in a row. This is longer than most previous recommendations. However, in order to obtain good fragmentation and control flyrock, a sufficient delay is needed so that the burden from previously fired holes has enough time to move forward to accommodate broken rock from subsequent rows. If the delay between rows is too short, movement in the back rows will be upward rather than outward (fig. 75).

3. Where airblast is a problem, the delay between holes in a row should be at least 2 ms per foot of spacing. This will prevent airblast from one charge from adding to that of subsequent charges as the blast proceeds down the row.

4. For the purpose of controlling ground vibrations, most regulatory authorities consider two charges to be separate events if they are separated by a delay of 9 ms or more.

Following these recommendations should yield good blasting results. However, when using surface delay systems such as detonating cord connectors and sequential timing blasting machines, the chances for cutoffs will be increased. To solve this problem, in-hole delays should be used in addition to the surface delays. For instance, when using surface detonating cord connectors, one might use a 100-ms delay in each hole. This causes ignition of the in-hole delays well in advance of rock movement, thus minimizing cutoffs. With a sequential timer, the same effect can be accomplished by avoiding the use of electric caps with delays shorter than 75 to 100 ms.

From the standpoint of simplicity in blast design it is best if all the explosive in a blasthole is fired as a single column charge. However, it is sometimes necessary, where firing large blastholes in populated areas, to use two or more delayed decks within a blasthole to reduce ground vibrations. Blast rounds of this type can become quite complex, and should be designed under the guidance of a competent person.

All currently used delay detonators employ pyrotechnic delay elements. That is, they depend on a burning powder train for their delay. Although these delays are reasonably accurate,

overlaps have been known to occur (9). Therefore, when it is essential that one charge fires before an adjacent charge, such as in a tight corner of a blast, it is a good idea to skip a delay period. Development of blasting caps with electronic delays is a good future possibility.

**POWDER FACTOR**

Powder factor, in the opinion of the authors, is not the best tool for designing blasts.

Blast designs should be based on the dimensions discussed earlier in this chapter. However, powder factor is a necessary calculation for cost accounting purposes. In blasting operations such as coal stripping or construction work where the excavated material has little or no inherent value, powder factor is usually expressed in terms of pounds of explosive per cubic yard of material broken. Powder factors for surface blasting can vary from 0.25 to 2.5 lb/cu yd, with 0.5 to 1.0 lb/cu yd being most typical.

Powder factor for a single blasthole is calculated by the following formula:

$$P.F. = \frac{L(0.3405d)(D^2)}{(B)(S)(H)/(27)}$$

where P.F. = powder factor, pounds of explosive per cubic yard of rock,

- L = length of the explosive charge, feet,
- d = density of the explosive, grams per cubic centimeter,
- D = charge diameter, inches,
- B = burden dimension, feet,
- S = spacing dimension, feet,
- H = bench height, feet.

and

Many explosives companies publish tables that give loading densities in pounds per foot of blasthole for different combinations of d and D. The nomograph in figure 14 also calculates the density in pounds per foot of borehole. Powder factor is a function of type of explosive, rock density, and geology. Table 6 gives typical powder factors for surface blasting.

Higher energy explosives, such as those containing large amounts of aluminum, can break more rock per pound than lower energy explosives. However, most of the commonly used explosive products have fairly similar energy values and thus have similar rock breaking capabilities. Soft, light rock requires less explosive per yard than hard, dense rock. Large-hole patterns require less explosive per yard of rock blasted because a larger proportion of stemming is used. Of course, larger blastholes frequently result in coarser fragmentation because of poorer powder distribution. Massive rock with few existing cracks or planes of weakness requires a higher powder factor than a formation that has numerous, closely spaced geologic flaws. Finally, the more free faces a blast has to break

to, the lower will be the powder factor. For instance a corner cut, with two vertical free faces, will require less powder than a box cut with only one vertical free face; and a box cut will require less powder than a sinking cut, which has only the ground surface as a free face. In a sinking cut it is desirable, where possible, to open a second free face by using a V-cut somewhere near the center of the round. V-cuts are discussed in more detail in the "Underground Blasting" section of this chapter.

When blasting materials that have an inherent value per ton, such as limestone or metallic ores, powder factors are sometimes expressed as pounds of explosive per ton of rock or tons of rock per pound of explosive.

**SECONDARY BLASTING**

Some primary blasts, no matter how well designed, will leave boulders that are too large to be handled efficiently by the loading equipment or large enough to cause plugups in crushers or preparation plants. Secondary fragmentation techniques must be used to break these boulders.

In the case of boulders too large to be handled, the loader operator will set the boulders aside for treatment. Identifying material large enough to cause plugups is not always quite so apparent. The operator must be instructed to watch for material that is small enough for convenient loading but which is large enough to cause a bottleneck later in the processing cycle.

Secondary fragmentation can be accomplished in four ways:

1. A heavy ball suspended from a crane may be dropped repeatedly on the boulder until the boulder breaks. This is a relatively inefficient method, and breaking a large or tough (nonbrittle) rock may take a considerable period of time. This method is adequate where the number of boulders produced is not excessive.

2. A hole may be drilled into the boulder and a wedging device inserted to split the boulder. This is also a slow method but may be satisfactory where only a limited amount of secondary fragmentation is necessary. An advantage of this method is that it does not create the flyrock associated with explosive techniques or, to some degree with drop balls.

3. Loose explosive may be packed into a crack or depression in the boulder, covered with damp earthen material, and fired. This type of charge is called a mudcap, plaster, or adobe charge. This method is inefficient because of a lack of explosive confinement, and relatively large amounts of explosive are required. The result is considerable noise and flyrock, and often, an inadequately broken boulder. The system is hazardous because the primed charge, lying on the surface, is prone to accidental initiation by external impacts from falling rocks or equipment. External charges should be used to break boulders only where drilling a hole is impractical, and when used, extreme caution concerning noise, flyrock, and accidental initiation through impact must be exercised. If it is found necessary to shoot a multiple mudcap blast, long delays or cap and fuse are not recommended.

4. The most efficient method of secondary fragmentation is through the use of small (1- to 3-in) boreholes loaded with explosives. The borehole is normally collared at the most convenient location such as a crack or a depression in the

**Table 6. - Typical powder factors for surface blasting**

<u>Degree of difficulty</u> <u>in rock breakage</u>	<u>Powder factor,</u> <u>lb/cu yd</u>
Low .....	0.25-0.40
Medium .....	.40- .75
High .....	.75-1.25
Very high .....	1.25-2.50



rock, and is directed toward the center of mass of the rock. The hole is drilled two-thirds to three-fourths of the way through the rock. Because the powder charge is surrounded by free faces, less explosive is required to break a given amount of rock than in primary blasting. One-quarter pound per cubic yard will usually do the job. Careful location of the charge is more important than its precise size. When in doubt it is best to estimate on the low side and underload the boulder. With larger boulders it is best to drill several holes to distribute the explosive charge, rather than placing the entire charge in a single hole. All secondary blastholes should be stemmed. As a cautionary note, secondary blasts are usually more violent than primary blasts.

Any type of initiation system may be used to initiate a secondary blast. For connecting large numbers of boulders, where noise is not a problem, detonating cord is often used. The "Detonating Cord Initiation" section in chapter 2 describes precautions to be taken against cord cutoffs. Electric blasting is also frequently used.

Although secondary blasting employs relatively small charges, its potential hazards must not be underestimated. Flyrock is often more severe and more difficult to predict than with primary blasting. Secondary blasts require at least as much care in guarding as do primary blasts. Secondary blasting can truly be called an art, with experience being an important key to success.

## UNDERGROUND BLASTING

Underground blast rounds can be divided into two basic categories—(1) heading, drift, or tunnel rounds, in which the only free face is the surface from which the holes are drilled, and (2) bench or stope rounds in which there is one or more free faces in addition to the face on which the blastholes are drilled. Blasts falling under the second category are designed in the same way as surface blast rounds. This discussion will cover blasts falling under the first category, only one initial free face.

### OPENING CUTS

The initial and most critical part of a heading round is the opening cut. The essential function of this cut is to provide additional free faces to which the rock can be broken. The du Pont Blaster's Handbook (4) discusses opening cuts. Although there are many specific types of opening cuts, and the terminology can be quite confusing, all opening cuts fall into one of two classifications; angled cuts, and parallel hole cuts (fig.76).

An angled cut, which may be referred to as a V-cut, draw cut, slab cut, or pyramid cut, breaks out a wedge of rock to create an opening to which the remaining holes can displace their burdens. Angled cuts are difficult to drill accurately. The bottoms of each pair of cut holes should be as close as possible. If they cross, the depth of round pulled will be less than designed. If bottoms are more than a foot or so apart, the round may not pull to its proper depth. The angle between the cut holes should be 60° or more, to minimize bootlegging. Some mines that drill a standard angled cut supply their drillers with a template to assure proper spacing and angles of the angled holes. The selection of the specific type of angled cut is a function of the rock, the type of drilling equipment, the philosophy of mine management, and the individual driller. A considerable amount of trial and error is usually involved in determining the best angled cut for a specific mine. In small openings it is often impossible to position the drill properly to drill an angled cut. In this case a parallel hole cut must be used.

Parallel hole cuts, which may also be called Michigan cuts, Cornish cuts, shatter cuts, burn cuts, or Coromant cuts, are basically a series of closely spaced holes, some loaded and some not loaded (fig. 77) which, when fired, pulverize and eject a cylinder of rock to create an opening to which the burdens on the remaining holes can be broken. Because they require higher powder factors and more drilling per volume of rock blasted, the use of parallel hole cuts is usually restricted to narrow headings, where there is not enough room to drill an angled cut.

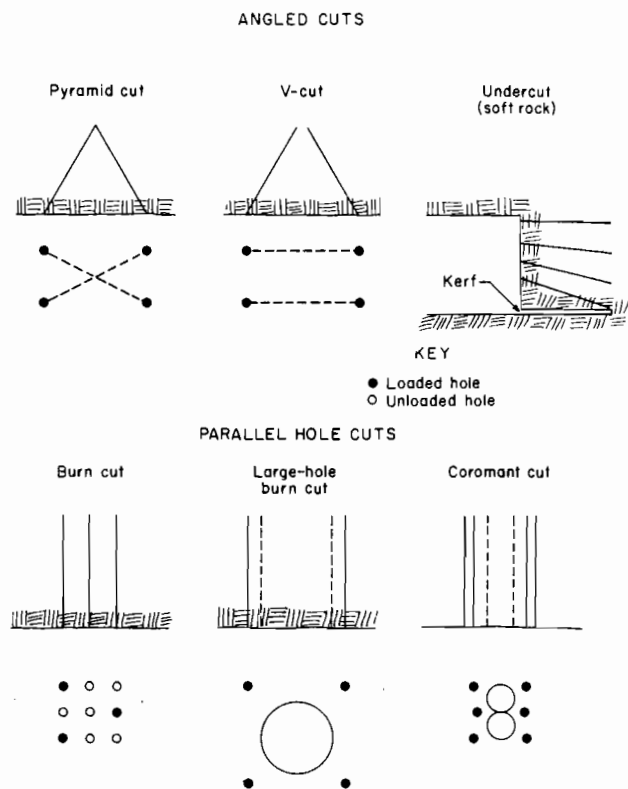
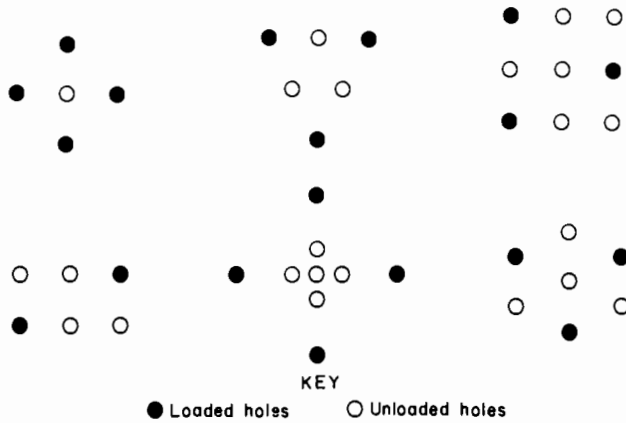

Figure 76.—Types of opening cuts.

Parallel hole cuts involve more drilling than angled cuts because the closely spaced holes break relatively small volumes of rock. However, they are relatively easy to drill because the holes are parallel. Like angled cuts, accurately drilled parallel hole cuts are essential if the blast round is to pull properly. Some drill jumbos have automatic controls to assure that holes are drilled parallel. Units of this type are a good investment for mines that routinely drill parallel hole cuts. A template may also be used in drilling a parallel hole cut (fig. 78).

The selection of the type of parallel hole cut depends on the rock, the type of drilling equipment, the philosophy of mine management, and the individual driller. As with angled cuts,



**Figure 77.—Six designs for parallel hole cuts.**

trial and error is usually involved in determining the best parallel hole cut for a specific mine.

For all types of opening cuts it is important that the cut pulls to its planned depth, because the remainder of the round will

not pull more deeply than the cut. In blasting with burn cuts, care must be exercised not to overload the burn holes, as this may cause the cut to "freeze" or not pull properly. Proper loading of the cut depends on the design of the cut and the type of rock being blasted, and often must be determined by trial and error.

Some research has been done involving burn cuts with one or more large central holes (8), and a few mines have adopted this practice. The advantage of the large central hole is that it gives a dependable void to which succeeding holes can break, which is not always obtained with standard burn cuts. This assures a more dependable and deeper pull of the blast round. The disadvantages of the large central hole are the requirement for an extra piece of equipment to drill the large hole and the extra time involved. Sometimes a compromise is used where intermediate-sized holes, such as 4- or 5-in diameter, are drilled using the same equipment used to drill the standard blastholes.

In some soft materials, particularly coal, the blasted cut is replaced by a sawed kerf, usually at floor level (fig. 79). In addition to giving the material a dependable void to which to break, the sawed cut assures that the floor of the opening will be smooth.

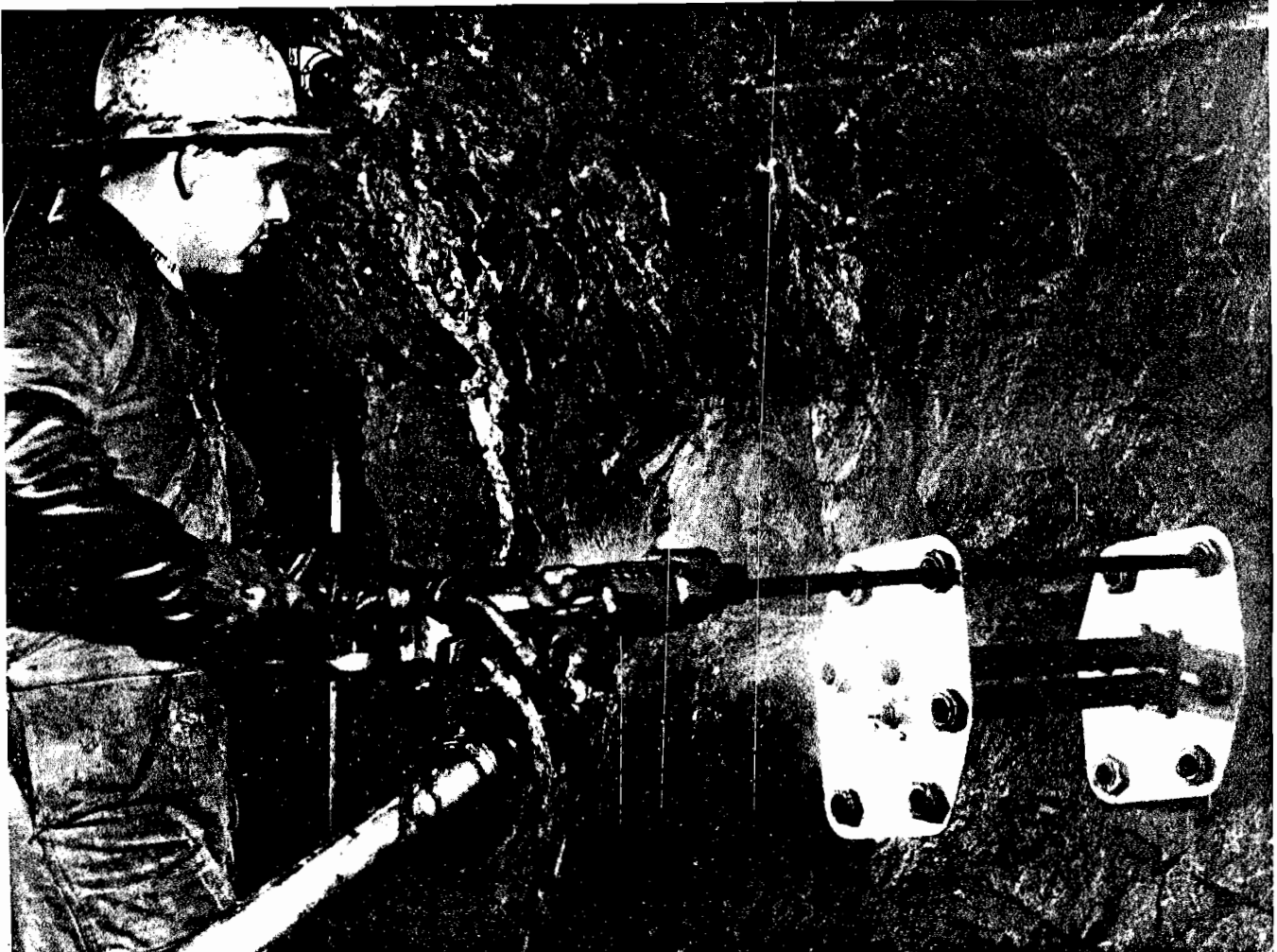

**Figure 78.—Drill template for parallel hole cut. (Courtesy Du Pont Co.)**

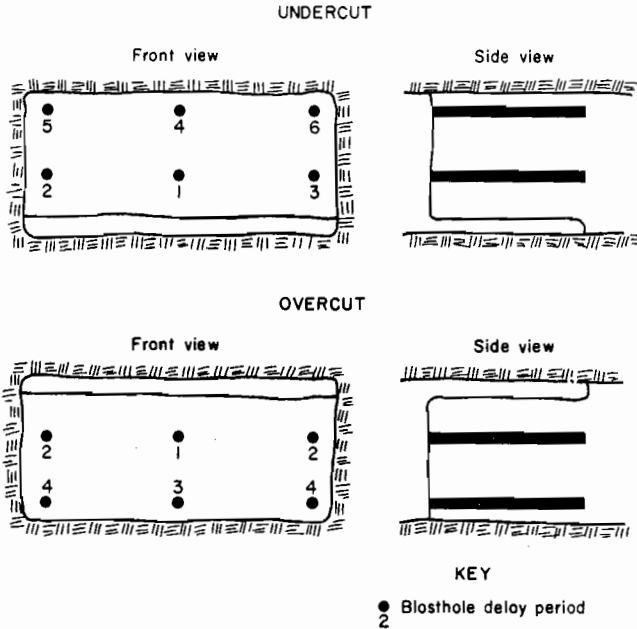

Figure 79.—Blast round for soft material using a sawed kerf.

**BLASTING ROUNDS**

Once the opening cut has established the necessary free face, the remainder of the blastholes must be positioned so that they successively break their burdens into the void space. It is important to visualize the progression of the blast round so that each hole, at its time of initiation, has a proper free face parallel or nearly parallel to it. Figure 80 gives the typical nomenclature for blastholes in a heading round.

The holes fired immediately after the cut holes are called the reliefs. The burdens on these holes must be carefully planned.

If the burdens are too small the charges will not pull their share of the round. If the burdens are too large the round may freeze owing to insufficient space into which the rock can expand. After several reliefs have been fired, the opening is usually large enough to permit the design of the remainder of

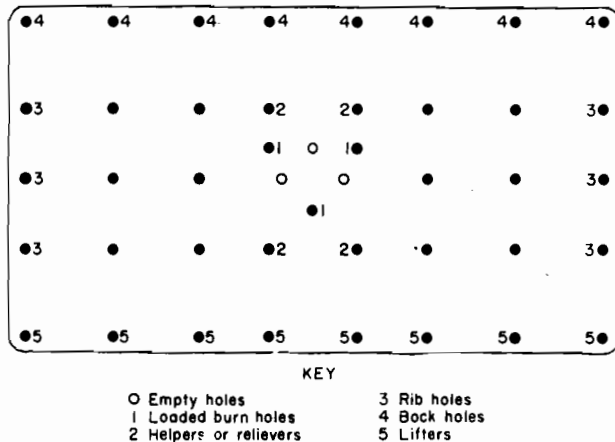

Figure 80.—Nomenclature for blastholes in a heading round.

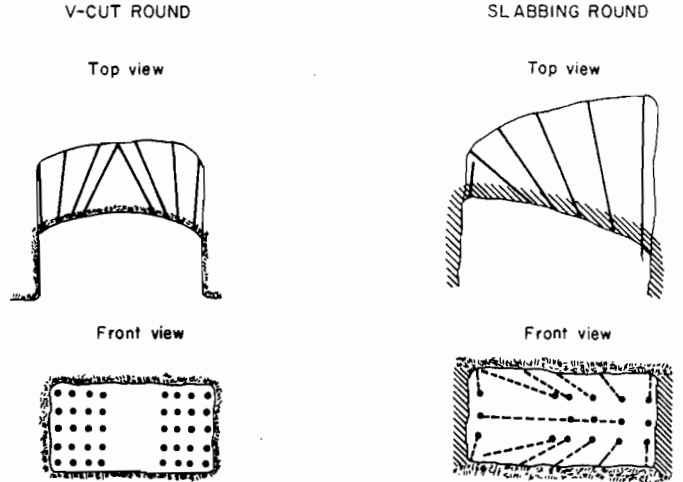

Figure 81.—Angled cut blast rounds.

the blast in accordance with the principles discussed under the "Surface Blasting" section. In large heading rounds, the burden and spacing ratios are usually slightly less than those for surface blasts. In small headings, where space is limited, the burden and spacing ratios will be still smaller. This is another area where trial and error plays a part in blast design.

The last holes to be fired in an underground round are the back holes at the top, the rib holes at the sides, and the lifters at the bottom of the heading. Unless a controlled blasting technique is used (discussed later in this chapter) the spacing between these perimeter holes is about 20 to 25 blasthole diameters. Figure 81 shows two typical angled cut blast rounds. After the initial wedge of rock is extracted by the cut, the angles of the subsequent blastholes are progressively reduced until the perimeter holes are parallel to the heading or looking slightly outward. In designing burden and spacing dimensions for angled cut blast rounds, the location of the bottom of the hole is considered rather than the collar.

Figure 82 shows two typical parallel hole cut blast rounds. It can be seen that these rounds are much simpler to drill than angled cut rounds. Once the central opening has been established, the round resembles a bench round turned on its

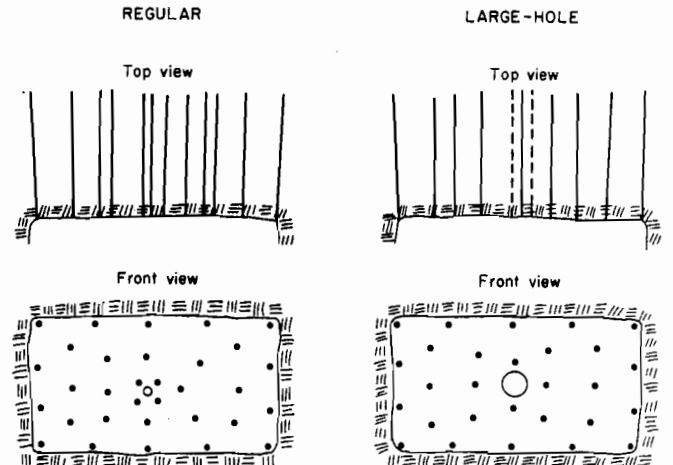

Figure 82.—Parallel hole cut blast rounds.

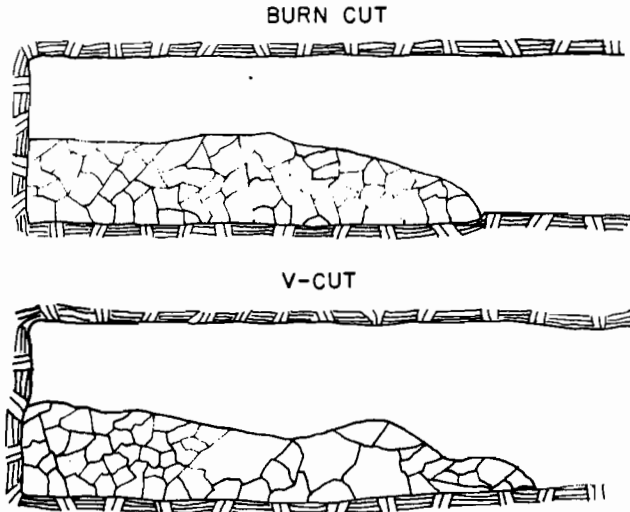

Figure 83.—Fragmentation and shape of muckpile as a function of type of cut.

side. Figure 83 shows a comparison of typical muckpiles obtained from V-cut and burn-cut blast rounds. Burn cuts give more uniform fragmentation and a more compact muckpile than V-cuts, where the muckpile is more spread out and variable in fragmentation. Powder factors and the amount of drilling required are higher for burn cuts.

**DELAYS**

Two series of delays are available for underground blasting; millisecond delays, which are the same as those used in surface blasting, and slow, or tunnel delays. The choice of delay depends on the size of the heading being blasted and on the fragmentation and type of muckpile desired. Slow delays give coarser fragmentation and usually give a more compact muckpile whereas millisecond delays give finer fragmentation and a more spread out muckpile (fig. 84). In small headings where space is limited, particularly when using parallel hole

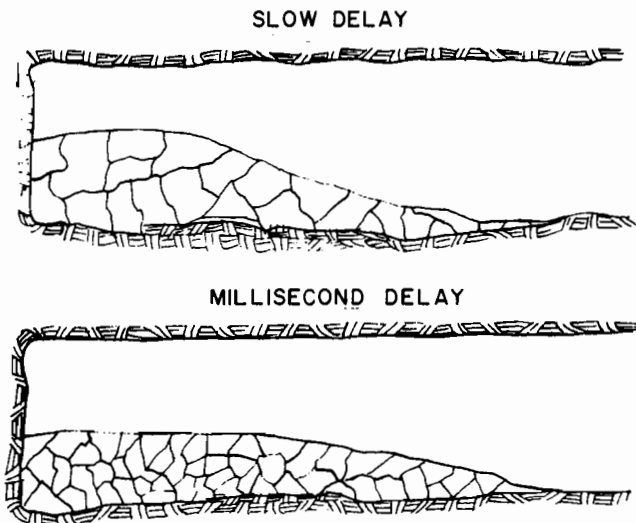

Figure 84.—Fragmentation and shape of muckpile as a function of delay.

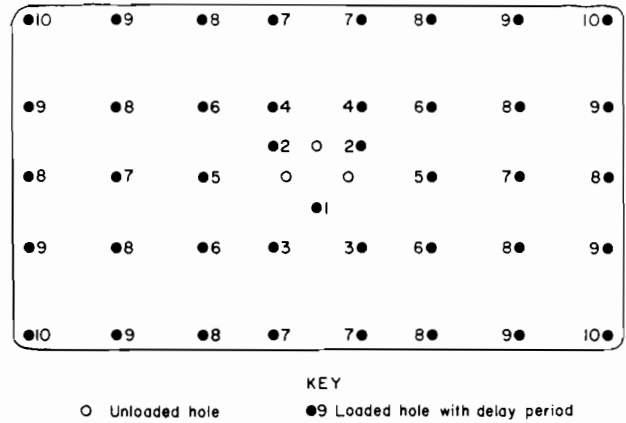

Figure 85.—Typical burn cut blast round delay pattern.

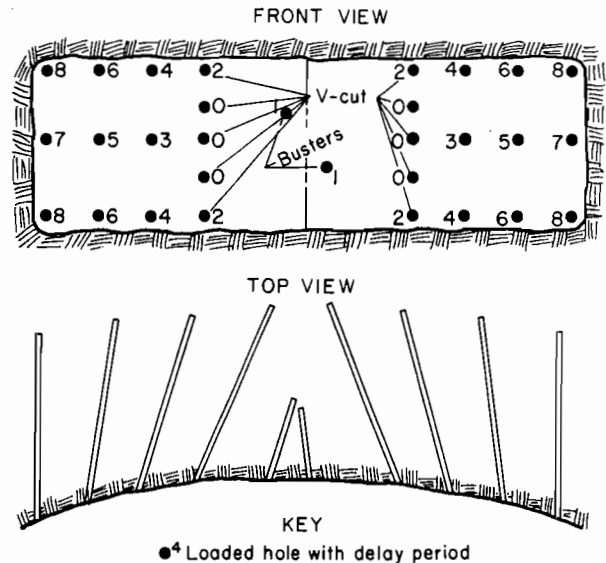

Figure 86.—Typical V-cut blast round delay pattern.

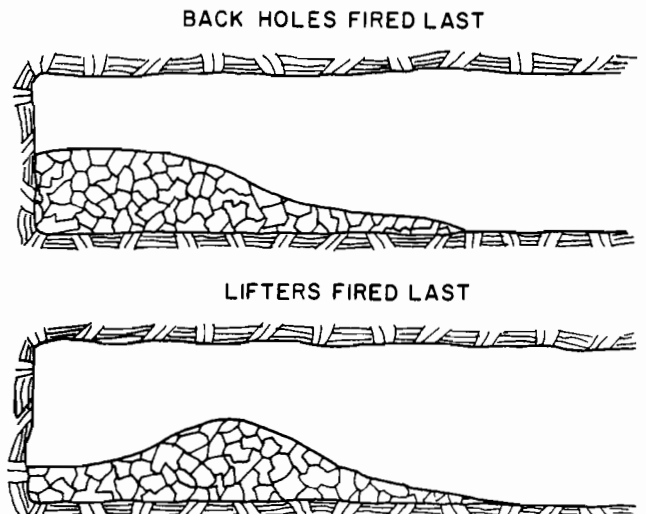

Figure 87.—Shape of muckpile as a function of order of firing.

cut rounds, slow delays are necessary to assure that the rock from each blasthole has time to be ejected before the next hole fires. Where a compromise between the results of millisecond delays and slow delays is desired, some operators use millisecond delays and skip delay periods.

In an underground blast round it is essential that the delay pattern be designed so that each hole, at its time of firing, has a good free face to which it can displace its burden. Figure 85 shows a typical delay pattern for a burn cut blast round in a heading in hard rock. Figure 86 shows a delay pattern for a V-cut blast round.

The shape of the muckpile is affected by the order in which the delays are fired (fig. 87). If the blast is designed so that the back holes at the roof are fired last, a cascading effect is

obtained, resulting in a compact muckpile. If the lifters are fired last, the muckpile will be displaced away from the face.

### **POWDER FACTOR**

As with surface blasting, powder factors for underground blasting vary depending on several factors. Powder factors for underground blasting may vary from 1.5 to 12 lb/cu yd. Soft, light rock, headings with large cross sections, large blastholes, and angle cut rounds all tend to give lower powder factors than hard, dense rock, small headings, small blastholes, and parallel hole cuts.

## **UNDERGROUND COAL MINE BLASTING**

Underground coal mine blasting is different from most rock blasting in two important respects. Operations take place in a potentially explosive atmosphere containing methane and coal dust, and the coal is much easier to break than rock. The loading and firing methods, as well as the explosive type, must be permissible, as specified by the Mine Safety and Health Administration (MSHA). In addition, underground coal mine blasting is closely regulated by State regulatory agencies. This discussion is intended to point out some of the main differences between coal blasting and rock blasting and should not be considered as a guide to regulatory compliance. Persons involved in underground coal mine blasting need to become thoroughly familiar with the MSHA regulations dealing with permissible blasting, which are identified in Appendix A, and those of the State in which they blast. Hercules (6) has published a shotfirer's guide for underground coal mine blasting.

Black powder or other nonpermissible explosives, including detonating cord, may not be stored or used in underground coal mines. Unconfined shots, that is, those not contained by boreholes, may not be fired although a permissible, external charge is currently under development. In most States the coal must be undercut (fig. 79) before blasting. The boreholes should not be deeper than the cut to assure that the coal is not fired off the solid. The minimum depth of cut should be 3½ ft.

Charge weights should not exceed 3 lb per borehole. Boreholes should have a minimum 18-in burden in all directions. If this specification cannot be met, the charge weight should be

reduced to prevent underburdened shots. Blast rounds should be limited to 20 holes. All holes should be bottom primed with the cap at the back of the hole, although this is not always required by regulation. Aluminum-cased detonators should not be used and leg wires should not be more than 16 ft long, or of equivalent resistance. Permissible blasting machines are designed to provide sufficient energy to a circuit using the rated number of electric blasting caps with 16-ft iron leg wires. Should these machines be used with copper wire detonators, their apparent capacity is increased. Zero-delay detonators should not be used in a circuit with millisecond-delay detonators.

Permissible explosives must remain in the original cartridge wrapper throughout storage and use, without admixture with other substances. Cartridges must be loaded in a continuous train, in contact with each other, and should not be deliberately crushed, deformed, or rolled. Permissible explosives must conform with their original specifications, within limits of tolerance prescribed by MSHA. The cartridge must be of a diameter which has been approved. All blastholes must be stemmed with incombustible material. Holes deeper than 4 ft should contain at least 24 in of stemming and holes less than 4 ft deep should be stemmed for at least half their length. Water stemming bags, when used, should be at least 15 in long and should have a diameter within ¼ in of the borehole diameter. Shots must be fired with a permissible blasting unit of adequate capacity.

## **CONTROLLED BLASTING TECHNIQUES**

The term controlled blasting is used to describe several techniques for improving the competence of the rock at the perimeter of an excavation. Du Pont, among other companies, has published an excellent pamphlet describing and giving general specifications for the four primary methods of controlled blasting (5). Much of this discussion is adapted from that publication. The recommended dimensions have been determined through years of on-the-job testing and evaluation. These recommended dimensions are given as ranges of values. The best value for a given blasting job is a function of the geology, specifically the number and severity of planes of weakness in the rock, and the quality of rock surface that is

required. Normal blasting activities propagate cracks into the excavation walls. These cracks reduce the stability of the opening. The purpose of controlled blasting is to reduce this perimeter cracking and thus increase the stability of the opening. Figure 88 shows a stable slope produced by controlled blasting.

### **LINE DRILLING**

Line drilling involves the drilling of a row of closely spaced holes along the final excavation line. It is not really a blasting



Figure 88.—Stable slope produced by controlled blasting. (Courtesy Austin Powder Co.)

technique since the line-drilled holes are not loaded with explosive. The line-drilled holes provide a plane of weakness to which the final row of blastholes can break and also reflect a portion of the blast's stress wave. Line drilling is used mostly in small blasting jobs and involves small holes in the range of 2- to 3-in diameter. Line drilling holes are spaced (center to center) two to four diameters apart. The maximum practical depth to which line drilling can be done is governed by how accurately the alignment of the holes can be held at depth, and is seldom more than 30 ft.

To further protect the final perimeter, the blastholes adjacent to the line drill are often more closely spaced and are loaded more lightly than the rest of the blast, using deck charges and detonating cord downlines if necessary. Best results are obtained in a homogeneous rock with little jointing or bedding, or when the holes are aligned with a major joint plane.

The use of line drilling is limited to jobs where even a light load of explosives in the perimeter holes would cause unacceptable damage. The results of line drilling are unpredictable, the cost of drilling is high, and the results are heavily dependent on the accuracy of drilling. Table 7 gives average specifications for line drilling.

Table 7. - Average specifications for line drilling

Hole diameter, in	Spacing, ft
2.00.....	0.33-0.67
3.00.....	.50-1.00

### PRESPLITTING

Presplitting, sometimes called preshearing, is similar to line drilling except that the holes are drilled farther apart and a very light load of explosive is used in the holes. Presplit holes are fired before any of the main blastholes adjacent to the presplit are fired. Although the specific theory of presplitting is in dispute, the light explosive charges propagate a sheared zone, preferably a single crack, between the holes, as shown in figure 89. In badly fractured rock, unloaded guide holes may be drilled between the loaded holes. The light powder load may be obtained by using specially designed slender cartridges, partial or whole cartridges taped to a detonating cord downline, explosive cut from a continuous reel, or even heavy grain detonating cord. A heavier charge of tamped cartridges is used in the bottom few feet of hole. Figure 90 shows three



Figure 89.—Crack generated by a presplit blast. (Courtesy Austin Powder Co.)

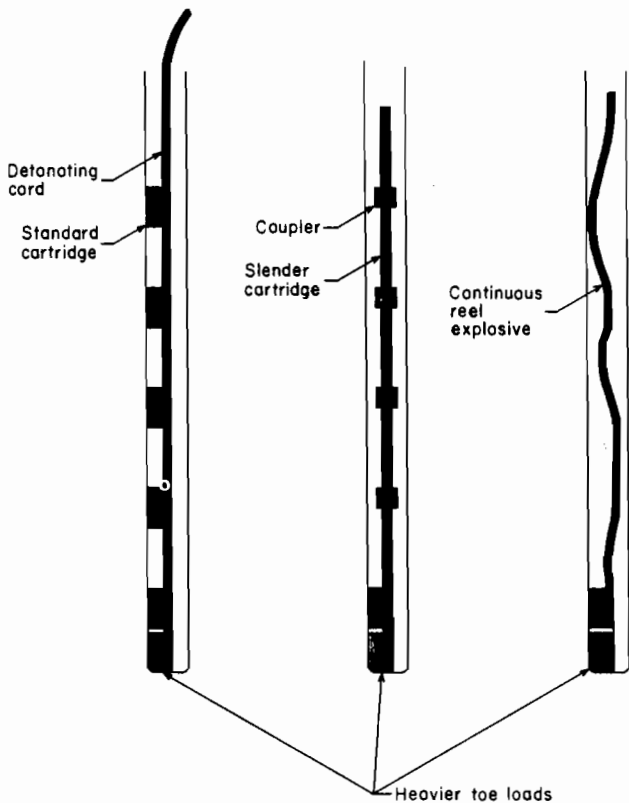

Figure 90.—Three typical blasthole loads for presplitting.

types of blasthole loads used for presplitting. Many operators now use 3/4- or 7/8-in by 2-ft cartridges connected with couplers.

It is desirable to completely stem around and between the cartridges in the borehole. It is also desirable, although not essential, to fire all the presplit holes on the same delay period. The maximum depth for a single presplit is limited by the accuracy of the drillholes, and is usually about 50 ft. A deviation of greater than 6 in from the desired plane of shear will give inferior results. One should avoid presplitting far ahead of the production blast. It is preferable to presplit a shorter section and dig that section out so that the quality of the presplit can be checked. If the presplit is unsatisfactory, adjustments can be made in subsequent blasts.

Some operators prefer to fire the presplit with the main blast by firing the presplit holes on the first delay period. Although presplitting is usually thought of as a surface blasting technique, it is occasionally used underground. The increased hole spacing reduces drilling costs as compared with line drilling. Table 8 gives average specifications for presplitting.

Table 8. - Average specifications for presplitting

Hole diameter, in	Spacing, ft	Explosive charge, lb/ft
1.50-1.75	1.00-1.50	0.08-0.25
2.00-2.50	1.50-2.00	.08- .25
3.00-3.50	1.50-3.00	.13- .50
4.00	2.00-4.00	.25- .75

### SMOOTH BLASTING

Smooth blasting, also called contour blasting, perimeter blasting, or sculpture blasting, is the most widely used method of controlling overbreak in underground openings such as drifts and stopes. It is similar to presplitting in that it involves a row of holes at the perimeter of the excavation that is more lightly loaded and more closely spaced than the other holes in the blast round. The light powder load is usually accomplished by "string loading" slender cartridges. Unlike presplitting, the smooth blast holes are fired after the main blast. This is usually done by loading and connecting the entire round and firing the perimeter holes one delay later than the last hole in the main round. As a first approximation, the burden on the perimeter holes should be approximately 1.5 times the spacing, as shown in figure 91. Table 9 gives average specifications for smooth blasting.

As a compromise between standard blasting and smooth blasting some operators slightly reduce the spacing of their perimeter holes, as compared with standard design, and string load regular cartridges of explosive. It is recommended procedure to seal the explosive column with a tamping plug, clay dummy, or other object to prevent the string-loaded charges from being extracted from the hole by charges on earlier delays.

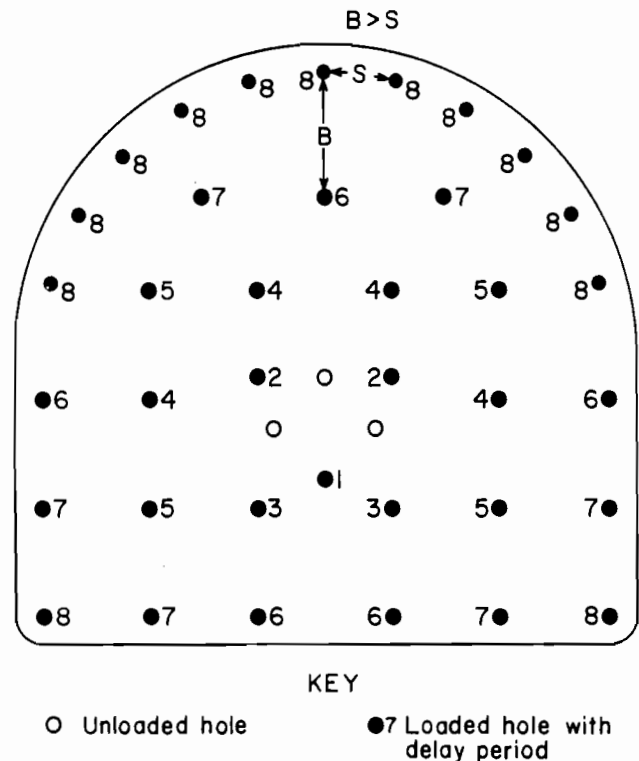

Figure 91.—Typical smooth blasting pattern (burden, B, is larger than spacing, S).

Table 9. - Average specifications for smooth blasting

Hole diameter, in	Spacing, ft	Burden, ft	Explosive charge, lb/ft
1.50-1.75	2.00	3.00	0.12-0.25
2.00	2.50	3.50	.12- .25



Smooth blasting reduces overbreak and reduces the need for ground support. This usually outweighs the cost of the additional perimeter holes.

### CUSHION BLASTING

Cushion blasting is surface blasting's equivalent to smooth blasting. Like other controlled blasting techniques, it involves a row of closely spaced, lightly loaded holes at the perimeter of the excavation. Holes up to 6½ in in diameter have been used in cushion blasting. Drilling accuracy with this size borehole permits depths of up to 90 ft for cushion blasting. After the explosive has been loaded, stemming is usually placed in the void space around the charges. The holes are fired after the main excavation is removed. A minimum delay between the holes is desirable. The same loading techniques that apply to presplitting are used with cushion blasting, except that the latter often involves larger holes. The burden on the cushion holes should always be larger than the spacing between holes.

The larger holes associated with cushion blasting result in larger spacings as compared with presplitting, thus reducing drilling costs. Better results can be obtained in unconsolidated formations than with presplitting, and the larger holes permit better alignment at depth. Table 10 gives average specifications for cushion blasting.

**Table 10. - Average specifications for cushion blasting**

Hole diameter, in	Spacing, ft	Burden, ft	Explosive charge, lb/ft
2.00-2.50	3.00	4.00	0.08-0.25
3.00-3.50	4.00	5.00	.13- .50
4.00-4.50	5.00	6.00	.25- .75
5.00-5.50	6.00	7.00	.75-1.00
6.00-6.50	7.00	9.00	1.00-1.50

### REFERENCES

1. Andrews, A. B. Design of Blasts. Emphasis on Blasting. Ensign Bickford Co. (Simsbury, CN), Spring 1980, pp. 1, 4.
2. Ash, R. L. The Mechanics of Rock Breakage, Parts I, II, III, and IV. Pit and Quarry, v. 56, No. 2, August 1963, pp. 98-112; No. 3, September 1963, pp. 118-123; No. 4, October 1963, pp. 126-131; No. 5, November 1963, pp. 109-111, 114-118.
3. Dick, R. A., and J. J. Olson. Choosing the Proper Borehole Size for Bench Blasting. Min. Eng., v. 24, No. 3, March 1972, pp. 41-45.
4. E. I. du Pont de Nemours & Co., Inc. (Wilmington, DE). Blaster's Handbook. 16th ed., 1978, 494 pp.
5. \_\_\_\_\_. Four Major Methods of Controlled Blasting. 1964, 16 pp.
6. Hercules, Inc. (Wilmington, DE). Shotfirer's Guide. 1978, 12 pp.
7. Pugleise, J. M. Designing Blast Patterns Using Empirical Formulas. BuMines IC 8550, 1972, 33 pp.
8. Schmidt, R. L., R. J. Morrell, D. H. Irby, and R. A. Dick. Application of Large-Hole Bum Cut in Room-and-Pillar Mining. BuMines RI 7994, 1975, 25 pp.
9. Winzer, S. R. The Firing Times of MS Delay Blasting Caps and Their Effect on Blasting Performance. Prepared for National Science Foundation (NSF APR 77-05171). Martin Marietta Laboratories (Baltimore, MD), June 1978, 36 pp.; available for consultation at Bureau of Mines Twin Cities Research Center, Minneapolis, MN.

## Chapter 5.—ENVIRONMENTAL EFFECTS OF BLASTING

There are four environmental effects of blasting.

1. Flyrock
2. Ground vibrations
3. Airblast
4. Dust and gases

Flyrock is a potential cause of death, serious injury, and property damage. Ground vibrations and airblast are potential causes of property damage and human annoyance, but are very unlikely to cause personal injury. Flyrock, ground vibrations, and airblast all represent wasted explosive energy. Excessive amounts of these undesirable side effects are caused by improper blast design or lack of attention to geology. When excessive side effects occur, part of the explosive energy that was intended to give the proper amount of rock fragmentation and displacement is lost to the surrounding rock and atmosphere. Serious dust or gas problems are seldom caused by blasting. A larger than normal amount of dust may be caused by a violent shot. Noxious gases, normally oxides of nitrogen or carbon monoxide, are the result of an inefficient explosive reaction. Because of its sporadic nature, blasting is not a significant source of air pollution.

When blasting in the vicinity of structures (fig. 92) such as homes, hospitals, schools, and churches, a preblast survey, documenting the condition of the structures, is often beneficial.

A preblast survey has a twofold purpose. First, it increases communications between the community and the mine operator. It has long been recognized that good public relations are the operator's best means of reducing blasting complaints. A preblast survey helps the operator to maintain good community relations. Many companies have been conducting preblasting surveys for years and have found them to be an excellent investment.

The second purpose of a preblast survey is to provide a baseline record of the condition of a structure against which the effects of blasting can be assessed. When combined with a postblast survey, this will help assure equitable resolution of blast damage claims. Office of Surface Mining (OSM) regulations require that a preblast survey be conducted, at the homeowners request, on all homes within 0.5 mi of blasting at surface coal mines.

Good blast recordkeeping is essential to any successful blasting operation. A blasting record is useful in troubleshooting the cause of undesirable blasting results such as flyrock, airblast, ground vibrations, and poor fragmentation. The blasting record may also provide excellent evidence in litigation on blast damage or nuisance. Figure 93 gives an example of a blasting record. Depending on the blasting situation, some of the information contained in figure 93 may not be required. On the reverse side of the blasting record a sketch of the blast pattern, including delays, and a sketch of a typical loaded hole should be drawn.



Figure 92.—Mining near a residential structure.

BLASTING RECORD

Date: \_\_\_\_\_

Company - \_\_\_\_\_

Location of blast: \_\_\_\_\_

Time of blast: \_\_\_\_\_

Date of blast: \_\_\_\_\_

Name of blaster: \_\_\_\_\_ License No: \_\_\_\_\_

Direction: \_\_\_\_\_ Distance: \_\_\_\_\_ feet from blast to nearest dwelling,  
school, church, commercial, or institutional building.Weather data: \_\_\_\_\_ Temperature: \_\_\_\_\_ Wind direction  
and speed: \_\_\_\_\_ Cloud cover: \_\_\_\_\_

Type of material blasted: \_\_\_\_\_

No. of holes: \_\_\_\_\_ Burden: \_\_\_\_\_ Spacing: \_\_\_\_\_ Depth: \_\_\_\_\_ Diam.: \_\_\_\_\_

Type of explosive used: \_\_\_\_\_

Maximum weight of explosive detonated within any 9-ms period: \_\_\_\_\_ lb.

Maximum number of holes detonated within any 9-ms period: \_\_\_\_\_

Total weight of explosives, including primers, this blast: \_\_\_\_\_ lb.

Method of firing and type of circuit: \_\_\_\_\_

Type and length of stemming: \_\_\_\_\_

Were mats or other protection used? \_\_\_\_\_

Type of delay detonator used: \_\_\_\_\_ Delay periods used: \_\_\_\_\_

Seismic data: T \_\_\_\_\_, V \_\_\_\_\_, L \_\_\_\_\_, dB \_\_\_\_\_

Location of seismograph: \_\_\_\_\_ Distance from blast: \_\_\_\_\_ ft.

Name of person taking seismograph reading: \_\_\_\_\_

Name of person and firm analyzing the seismograph record: \_\_\_\_\_

Signed: \_\_\_\_\_ Blaster

Figure 93.—Example of a blasting record.

## FLYROCK

Flyrock, primarily associated with surface mining, is the most hazardous effect of blasting. It is a leading cause of onsite fatalities and equipment damage from blasting. Occasionally flyrock will leave the mine site and cause serious injury and damage to persons and property beyond the mine limits. Flyrock distances can range from zero, for a well-controlled coal strip-mine blast, to nearly a mile for a poorly confined, large, hard-rock mine blast. The term flyrock can be defined as an undesirable throw of material. Muckpile displacements on the order of 100 ft are often desirable for certain types of loading equipment such as front-end loaders. Even larger displacements may be desirable for explosive casting of waste material.

### CAUSES AND ALLEVIATION

Excessive flyrock is most often caused by an improperly designed or improperly loaded blast (5).<sup>1</sup> A burden dimension less than 25 times the charge diameter often gives a powder factor too high for the rock being blasted. The excess explosive energy results in long flyrock distances. On the other hand, an excessively large burden may cause violence in the collar zone, especially where an inadequate amount or an ineffective type of stemming is used. This situation is compounded when top priming is used, as opposed to center or toe priming.

To prevent or correct flyrock problems, the blaster should make sure that the burden is proper and that enough collar distance is used. One-fourth-inch-size material makes better stemming than fines, particularly where there is water in the boreholes. In some cases it may be necessary to lengthen the stemming zone above the main charge and use a small deck charge to reduce flyrock and still assure that the caprock is broken. Top initiation is a particularly poor practice where flyrock is a problem. In multiple row shots, longer delays between later rows, on the order of 10 ms per foot of burden, may reduce flyrock. Precautions should be taken against cut-offs when using delays of this length.

Zones of weakness and voids are often causes of flyrock. These potential problems can sometimes be foreseen through

consultation with the drill operator and through past experience in the area being blasted. An abnormal lack of resistance to drill penetration usually indicates a mud seam, a zone of incompetent rock, or even a void. The driller should note the depth and the severity of this zone of weakness on the drill log. Any explosive loaded in this zone will follow the line of least resistance and "blow out," causing flyrock (fig. 59). Placing a few feet of stemming, rather than explosive, in this area will reduce the likelihood of flyrock (fig. 62). Void zones such as mine openings or solution cavities cause violent explosions when packed with explosives. It is always a good idea to measure the buildup of the column as explosive loading proceeds. If buildup is abnormally slow, the zone should be stemmed and the powder column continued above it. Measuring the column buildup will also assure that adequate room is left for stemming above the charge.

### PROTECTIVE MEASURES

Despite careful planning and good blast design, flyrock may occasionally occur and must always be protected against. Some margin for error must always be maintained. Abnormally long flyrock distances should be measured and recorded for future reference. The size of the guarded perimeter should take these cases into account. An adequate number of guards must be posted at safe distances. Any persons within this perimeter must have safe cover and must be adequately warned. Remember that warning signs, prearranged blasting times, or warning sirens, in themselves, are seldom adequate for blast guarding. It is particularly good if the blaster has a commanding field of view of the blast area so he or she can abort the shot at the last minute if necessary.

OSM surface coal mine regulations prohibit throwing flyrock beyond the guarded zone, more than one-half the distance to the nearest dwelling or occupied structure, and beyond the operator's property line. State and local flyrock regulations may also exist. In small, close-in construction blasts, special protective mats may be used to contain flyrock. However, this is impractical in mine blasts or other large blasts.

## GROUND VIBRATIONS

All blasts create ground vibrations. When an explosive is detonated in a borehole it creates a shock wave that crushes the material around the borehole and creates many of the initial cracks needed for fragmentation. As this wave travels outward, it becomes a seismic, or vibration wave. As the wave passes a given piece of ground it causes that ground to vibrate. The situation is similar to the circular ripples produced on the surface of a pool of calm water when it is struck by a rock (6). Ground vibrations are measured with seismographs (12) (fig. 94). They are measured in terms of amplitude (size of the vibrations) and frequency (number of times the ground

moves back and forth in a given time period). In blasting, amplitude is usually measured in terms of velocity (inches per second) and frequency is measured in hertz, or cycles per second. Excessively high ground-vibration levels can damage structures. Even moderate to low levels of ground vibration can be irritating to neighbors and can cause legal claims of damage and/or nuisance. One of the best protections against claims is good public relations (7). While striving to minimize ground vibrations, the blaster or the company should inform local residents of the need for and the importance of the blasting, and the relative harmlessness of properly controlled blasting vibrations when compared to the day-to-day stresses to which a structure is subjected. Prompt and sincere response to complaints is important.

<sup>1</sup> Italicized numbers in parentheses refer to items in the list of references at the end of this chapter.



Figure 94.—Seismograph for measuring ground vibrations from blasting.

### CAUSES

Excessive ground vibrations are caused either by putting too much explosive energy into the ground or by not properly designing the shot. Part of the energy that is not used in fragmenting and displacing the rock will go into ground vibrations. The vibration level at a specific location is primarily determined by the maximum weight of explosives that is used in any single delay period in the blast and the distance of that location from the blast (9).

The delays in a blast break it up into a series of smaller, very closely spaced individual blasts. The longer the intervals are

between delays, the better the separation will be between the individual blasts. Most predictive schemes and regulatory agencies use a guide of 8 or 9 ms as the minimum delay that can be used between charges if they are to be considered as separate charges for vibrations purposes. However, there is nothing magical about the 8- or 9-ms interval. For small, close-in blasts a smaller delay may give adequate separation.

With large blasts at large distances from structures, longer delays are required to obtain true separation of vibrations because the vibration from each individual charge lasts for a longer period of time. In general, vibration amplitudes at structures sitting on the formation of rock being blasted will be

greater than at structures sitting on other formations. However, they may be higher in frequency, which reduces the response of structures and the likelihood of damage.

In addition to charge weight per delay, distance, and delay interval, two factors may affect the level of ground vibrations at a given location. The first is overconfinement. A charge with a properly designed burden will produce less vibration per pound of explosive than a charge with too much burden (fig. 95). An excessive amount of subdrilling, which results in an extremely heavy confinement of the explosive charge, will also cause higher levels of ground vibration, particularly if the primer is placed in the subdrilling. In multiple row blasts, there is a tendency for the later rows to become overconfined (fig. 75). To avoid this, it is often advisable to use longer delay periods between these later rows to give better relief. In some types of ground these longer delays may increase the chance of cutoffs, so some tradeoffs must be made. Second, if delays proceed in sequence down a row, the vibrations in the direction that the sequence is proceeding will be highest (fig. 96) because of a snowballing effect.

Recent studies (13) have shown that millisecond delays in commercial detonators are less accurate than was previously

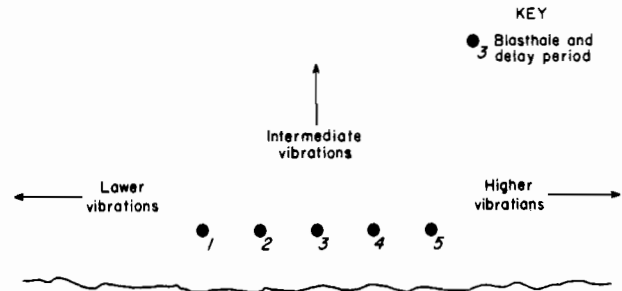
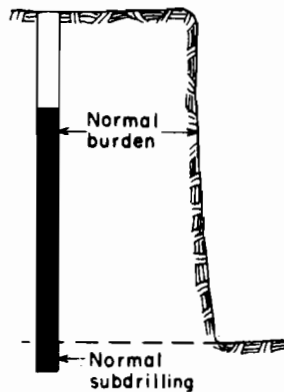

Figure 96.—Effect of delay sequence on particle velocity.

believed. This may result in extremely close timing between adjacent delay periods or, very rarely, an overlap. Where it is critical that one hole detonates before an adjacent hole to provide relief, it may be a good idea to skip a delay period between the two holes.

Most underground mines shoot relatively small blasts and do not have vibration problems. However, where vibrations are a problem, the discussions in this chapter apply to underground blasting as well as surface blasting.

#### NORMAL VIBRATIONS



#### EXCESSIVE VIBRATIONS

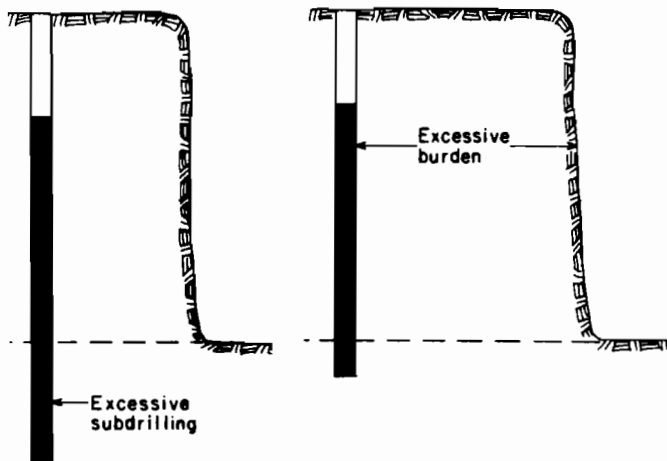

Figure 95.—Effects of confinement on vibration levels.

### PREScribed VIBRATION LEVELS AND MEASUREMENT TECHNIQUES

Two vibration limits are important; the level above which damage is likely to occur and the level above which neighbors are likely to complain. There is no precise level at which damage begins to occur. The damage level depends on the type, condition, and age of the structure, the type of ground on which the structure is built, and the frequency of the vibration, in hertz. Research completed by the Bureau of Mines in the late 1970's (9) recommends that for very close-in construction blasting, where the frequency is above 40 Hz, vibration levels be kept below 2 in/sec to minimize damage. However, all mine and quarry blast vibrations, and those from large construction jobs, have frequencies below 40 Hz. For these blasts it is recommended that the vibration level be kept below 0.75 in/sec for homes of modern, drywall construction and below 0.50 in/sec for older homes with plaster-on-lath walls. These values could change as more research is done.

People tend to complain about vibrations far below the damage level. The threshold of complaint for an individual depends on health, fear of damage (often greater when the owner occupies the home), attitude toward the mining operation, diplomacy of the mine operator, how often and when blasts are fired, and the duration of the vibrations. The tolerance level could be below 0.1 in/sec where the local attitude is hostile toward mining, where the operator's public relations stance is poor, or where numerous older persons own their homes. On the other hand where the majority of people depend on the mine for their livelihood, and where the mine does a good job of public relations, levels above 0.50 in/sec might be tolerated. By using careful blast design and good public relations it is usually possible for an operator to live in harmony with neighbors without resorting to expensive technology.

Several options are available for measuring ground vibrations (12). Many operators prefer to hire consultants to run their monitoring programs. Either peak reading seismographs or seismographs that record the entire vibration event on a paper record may be used. Peak reading instruments are

cheaper, easier to use, and are adequate for assuring regulatory compliance in most cases. However, seismographs that record the entire time history are more useful for understanding and troubleshooting ground vibration problems. Instruments that measure three mutually perpendicular components (radial, transverse, vertical) are most common, and most regulations specify this type of measurement. Vector sum instruments will always give a higher reading (usually 10 to 25 pct higher) than the highest single component of a three-component instrument. Because vector sum instruments always give a higher reading, they should be satisfactory for regulatory compliance even where the regulation specifies three components.

Some seismographs require an operator to be present while others operate remotely, usually for a period of a month between battery changes. Operator-attended instruments are cheaper but require the expense of the operator. They can be moved from place to place to gather specific data on specific blasts. Remotely installed instruments are useful in that they record each blast without sending an operator out each time. These instruments should be installed in places that are protected from weather and tampering. When recording remotely, it is easier to detect tampering with seismographs that record the entire time history than with peak reading instruments.

When accelerations larger than 0.3 g are expected, the seismograph should be secured to the ground surface. Many instruments are equipped with stakes for this purpose. Epoxy or bolting may be used on hard surfaces. Where possible, when the expected acceleration level is high, the gage should be buried in the ground.

Seismograph records provide excellent evidence in case of later complaints or lawsuits on damage or nuisance from blasting. A complete blast record, as shown in figure 93, describing the layout, loading, initiation, and other pertinent aspects of the blast is also essential.

### SCALED DISTANCE EQUATION

Where vibrations are not a serious problem, regulations will often permit the blaster to use the scaled distance equation rather than measuring vibrations with a seismograph. The scaled distance equation is as follows:

$$S.D. = D/W^{1/2}$$

where S.D. is the scaled distance, D is the distance from the blast to the structure of concern, in feet, and W is the maximum charge weight of explosives, in pounds, per delay of 9 ms or more. The scaled distance permitted depends on the allowable vibration level. For instance, Bulletin 656 (7) says that a scaled distance of 50 or greater will protect against vibrations greater than 2 in/sec. Therefore, at a distance of 500 ft, 100 lb of explosive could be fired; at 1,000 ft, 400 lb; at 1,500 ft, 900 lb, etc. The original OSM regulations (2-3) specified a scaled distance of 60 or greater to protect against 1 in/sec, giving distance-weight combinations of 600 ft and 100 lb; 1,200 ft and 400 lb, 1,800 ft and 900 lb, etc. This regulation is currently being revised.

The scaled distance approach works well when the mine is an adequate distance from structures, vibrations are not a problem, and the operator wants to save the expense of measuring vibrations. At close distances, however, the scaled distance becomes quite restrictive in terms of allowable charge weights per delay and monitoring is often a more economical option.

### REDUCING GROUND VIBRATIONS

A properly designed blast using the principles described in chapter 4 will give lower vibrations per pound of explosive than a poorly designed blast. Proper blast design includes using a spacing-to-burden ratio equal to or greater than 1.0, using proper delay patterns, and using a proper powder factor. Blasthole locations should be carefully laid out and drilling should be controlled as closely as possible. Bench marks should be established for use in setting out hole locations for the next blast before the current blast is made to avoid possible errors due to backbreak (4).

The following techniques can be used to reduce ground vibrations:

1. Reduce the charge weight of explosives per delay. This is most easily done by reducing the number of blastholes fired on each delay. If there are not enough delay periods available, this can be alleviated by using a sequential timer blasting machine or a combination of surface and in-hole nonelectric delays. The manufacturer should be consulted for advice when using the sequential timer or complex delay systems. If the blast already employs only one blasthole per delay, smaller diameter blastholes, a lower bench height, or several delayed decks in each blasthole can be used. Delays are often required when presplitting.
2. Overly confined charges such as those having too much burden or too much subdrilling should be avoided. The primer should not be placed in the subdrilling. Where it appears that a later row of blastholes will have inadequate relief, a delay period should be skipped between rows.
3. The length of delay between charges can be increased. This is especially helpful when firing large charge weights per delay at large blast-to-structure distances. However, this will increase the duration of the blast and may cause more adverse reactions from neighbors.
4. If delays in a row are arranged in sequence, the lowest delay should be placed in the hole nearest the structure of concern. In other words, the shot should be propagated in a direction away from the structure.
5. The public's perception of ground vibrations can be reduced by blasting during periods of high local activity such as the noon hour or shortly after school has been dismissed. Blasting during typically quiet periods should be avoided, if possible.

### AIRBLAST

Airblast is a transient impulse that travels through the atmosphere. Much of the airblast produced by blasting has a

frequency below 20 Hz and cannot be heard effectively by the human ear. However, all airblast, both audible and inaudible,

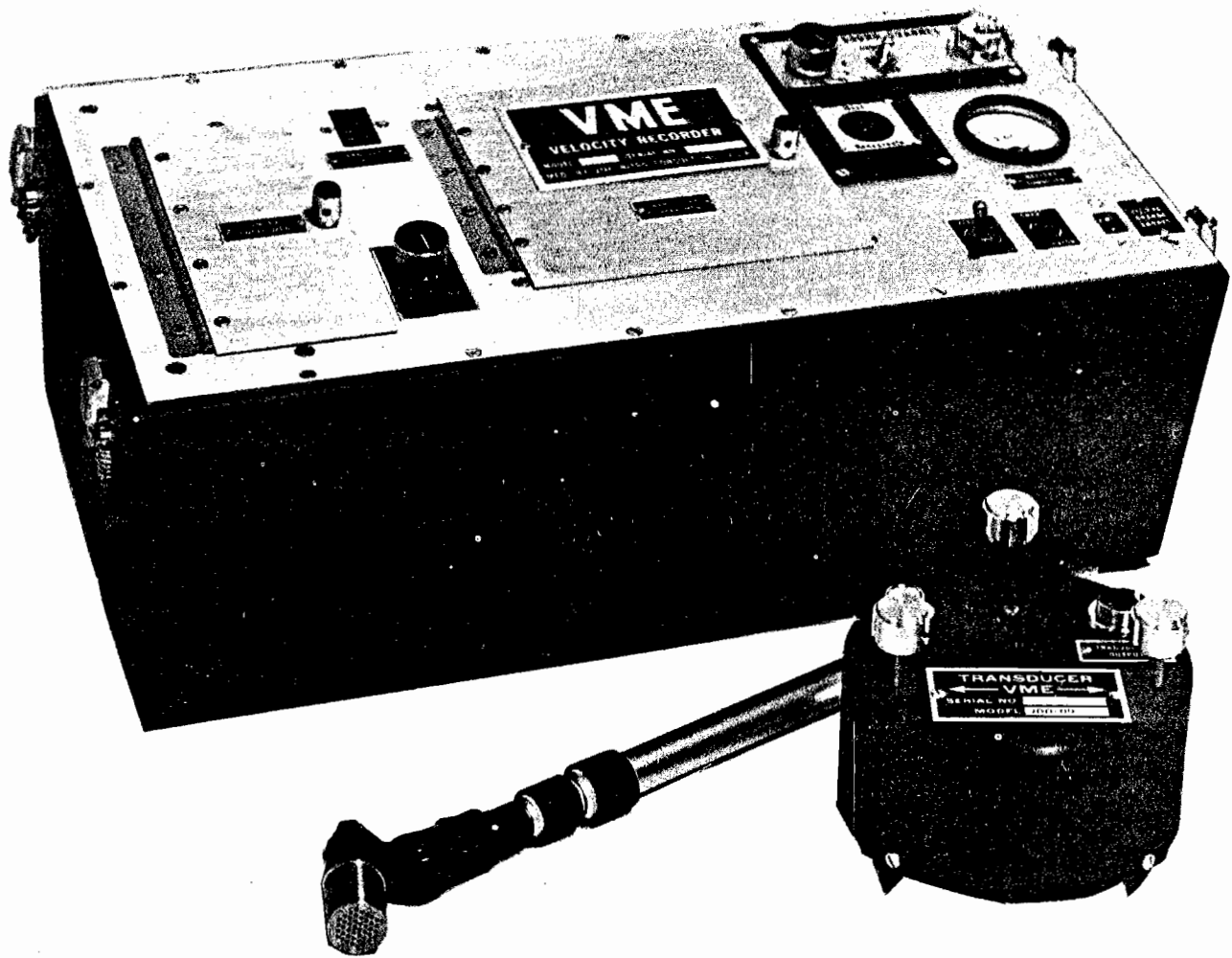

Figure 97.—Blasting seismograph with microphone for measuring airblast.

can cause a structure to vibrate in much the same way as ground vibrations (8, 10). Airblast is measured with special gages, pressure transducers, or wide-response microphones (11). These instruments are often an integral part of blasting seismographs (fig. 97). As with ground vibrations, both amplitude and frequency are measured. Amplitude is usually measured in decibels, sometimes in pounds per square inch, and frequency is measured in hertz. Research has shown that airblast from a typical blast has less potential than ground vibrations to cause damage to structures. It is, however, frequently the cause of complaints. When a person senses vibrations from a blast, or experiences house rattling, it is usually impossible to tell whether ground vibrations or airblast is being sensed. A discussion of airblast should be part of any mine public relations program.

### CAUSES

Airblast is caused by one of three mechanisms (6) as shown in figure 98. The first cause is energy released from unconfined explosives such as uncovered detonating cord trunklines

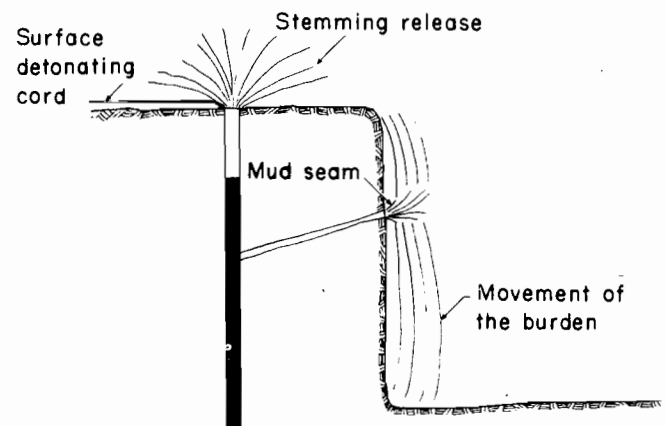

Figure 98.—Causes of airblast.



or mudcaps used for secondary blasting. The second cause is the release of explosive energy from inadequately confined borehole charges. Some examples are inadequate stemming, inadequate burden, or mud seams. The third cause is movement of the burden and the ground surface. Most blasts are designed to displace the burden. When the face moves out, it acts as a piston to form an air compression wave (airblast). For this reason, locations in front of the free face receive higher airblast levels than those behind the free face.

### PREScribed AIRBLAST LEVELS AND MEASUREMENT TECHNIQUES

Siskind (8) has studied the problem of damage from airblast. Table 11 shows the airblast levels prescribed for preventing damage to structures.

As indicated in the table, different instruments have different lower frequency limits. Because much of the airblast is contained in these lower frequency levels, some of the instruments measure more of the airblast than others. That is the reason for the different maximum levels in the table. It is necessary to meet only one of these values, depending on the specifications of the instrument used.

Because airblast is a major cause of blasting complaints, merely meeting the levels given in the table is sometimes not sufficient. Airblast levels should be kept as low as possible by using the techniques described later in this section. This will go a long way toward reducing complaints and conflicts with neighbors.

Any instrument with a frequency range listed in table 11 can be used to measure airblast. Many operators prefer to hire consultants to monitor airblast. Most of the discussion under ground vibration measurement techniques also applies to airblast measurement. Both peak reading instruments and those that record the entire airblast time history are available. The peak reading devices are satisfactory for regulatory compliance but those that record the entire airblast time history are much better for troubleshooting purposes. A single airblast reading is taken at a given location. The gage should be 3 to 5 ft above the ground and should be at least 5 ft to one side of any structure to prevent distortion to the record due to airblast reflections.

Airblast can be measured by an operator-attended instrument or by a remotely installed instrument. Operator-attended instruments are cheaper but require the expense of the operator. They are more flexible in that data can be recorded at different locations for different blasts. Remotely installed instruments are useful in that they record each blast fired without requiring an operator each time. One disadvantage of remote monitoring is that a high reading can be induced by a loud noise near the instrument. For this reason, instruments that record the entire airblast event are recommended for remote monitoring, so that a nonblasting event can be identified by its noncharacteristic wave trace.

It is recommended that all airblast monitors be equipped with wind screens to cut down the background noise level and protect the microphone. Remotely installed instruments should be protected from the weather.

**Table 11. - Maximum recommended airblast levels**

<u>Frequency range of instrumentation</u>	<u>Maximum level, dB</u>
0.1 to 200 Hz, flat response .....	134 peak.
2 to 200 Hz, flat response .....	133 peak.
6 to 200 Hz, flat response .....	129 peak.
C-weighted, slow response .....	105 C.

Airblast recordings provide good evidence in case of complaints or lawsuits. Airblast readings taken in conjunction with ground vibration readings are especially helpful in determining which of the two are the primary cause of complaints.

### REDUCING AIRBLAST

Properly executed blasts, where surface explosives are adequately covered and borehole charges are adequately confined, are not likely to produce harmful levels of airblast. Close attention must be paid to geology to prevent the occasional "one that gets away from you."

The following techniques can be used to reduce airblast.

1. Unconfined explosives should not be used. Where surface detonating cord is used it should be buried. Cords with lighter core loads require less depth of burial.
2. Sufficient burden and stemming on the blastholes are essential. Where the length of stemming is marginal, coarse stemming material will give better charge confinement than fines, particularly where there is water in the stemming zone. One-fourth-inch material makes excellent stemming. A longer stemming dimension should be used where part of the burden at the crest has been robbed from the front row of holes. The front row of holes usually creates more airblast than subsequent rows.
3. Geologic conditions that cause blowouts should be compensated for. These include mud seams, voids, or open bedding (should be stemmed through) and solution cavities or other openings (a check of column rise will avoid overloading).
4. Holes must be drilled accurately to maintain the designed burden. This is especially important with inclined holes.
5. If there is a high free face in the direction of nearby built-up areas, the face should be reorientated, if possible, or reduced in height.
6. Collar priming should be avoided where airblast is a problem. (Actually, collar priming is seldom desirable.)
7. Early morning, late afternoon, or night firing, when temperature inversions are most likely, should be avoided. Blasting when a significant wind is blowing toward nearby built-up areas will increase airblast.
8. Use of longer delays between rows than between holes in a row will promote forward rather than upward movement of the burden. Five milliseconds per foot of burden between rows is a good rule of thumb, but this should be increased in later rows for shots with many rows.
9. Excessively long delays that may cause a hole to become unburdened before it fires should be avoided.

Public reaction to airblast can be reduced by blasting during periods of high activity such as the noon hour or shortly after school has been dismissed. Blasting during quiet periods should be avoided.

## DUST AND GASES

Every blast generates some amount of dust and gases. The amounts of dust generated by blasting do not present a serious problem. Other phases of the mining operation such as loading, hauling, crushing, and processing produce considerably more dust than blasting. Even though a violent blast may produce more than the normal amount of dust, blasting is a relatively infrequent operation and, as a result, the total amount of dust produced in a day is insignificant when compared to other sources. Well controlled blasts create little or no dust. Because dust in the muckpile can be a problem to mine personnel, it is common practice to thoroughly wet the muckpile before and during mucking operations. In underground operations an appropriate amount of time is allowed for the dust to settle or to be expelled from the area by the ventilation system before miners enter the blast area.

The most common toxic gases produced by blasting are carbon monoxide and oxides of nitrogen. While these gases

are considered toxic at levels of 50 ppm and 5 ppm respectively, blast fumes are quickly diluted to below these levels by the ventilation systems in underground mines and by natural air movement in surface mines. In underground operations, it is important to allow time for toxic gases to be expelled by the ventilation system before miners enter the area. In surface mining, it is a good idea to wait for a short period of time before entering the immediate blast area, particularly if orange-brown fumes (oxides of nitrogen) are present. It is extremely rare for significant concentrations of toxic gases to leave the mine property. If large amounts of orange-brown fumes are consistently present after blasts, the source of the problem should be determined and corrected. The primary causes of excessive nitrogen oxides are poor blasting agent mixtures, degradation of blasting agents during storage, use of non-water-resistant products in wet blastholes, and inefficient detonation of the blasting agent due to loss of confinement.

## REFERENCES

1. Bauer, A., and J. W. Sanders. Good Blasting Techniques and Public Relations. Min. Cong. J., v. 54, No. 11, November 1968, pp. 81-85.
2. Dick, R. A. A Review of the Federal Surface Coal Mine Blasting Regulations. Proc. 5th Conf. on Explosives and Blasting Technique, St. Louis, MO, Feb. 7-9, 1979. Society of Explosives Engineers, Montville, OH, pp. 1-7.
3. Dick, R. A., and D. E. Siskind. Ground Vibration Technology Pertaining to OSM Regulations. Proc. Symp. on Surface Coal Mining and Reclamation Coal Conf. & Expo., Louisville, KY, Oct. 23-25, 1979. McGraw-Hill, New York, pp. 13-18.
4. E. I. du Pont de Nemours & Co., Inc. (Wilmington, DE). Blaster's Handbook. 16th ed., 1978, 494 pp.
5. Lundborg, N., P. A. Persson, A. Ladegaard-Pederson, and R. Holmberg. Keeping the Lid on Flyrock From Open Pit Blasting. Eng. and Min. J., v. 176, No. 5, May 1975, pp. 95-100.
6. Miller, P. Blasting Vibration and Airblast. Atlas Powder Co. (Dallas, TX), 16 pp.
7. Nicholls, H. R., C. F. Johnson, and W. I. Duvall. Blasting Vibrations and Their Effects on Structures. BuMines B 656, 1971, 105 pp.
8. Siskind, D. E., V. J. Stachura, M. S. Stagg, and J. W. Kopp. Structure Response and Damage Produced by Airblast From Surface Mining. BuMines RI 8485, 1980, 111 pp.
9. Siskind, D. E., M. S. Stagg, J. W. Kopp, and C. H. Dowding. Structure Response and Damage Produced by Ground Vibration From Surface Mine Blasting. BuMines RI 8507, 1980, 74 pp.
10. Siskind, D. E., and C. R. Summers. Blast Noise Standards and Instrumentation. BuMines TPR 78, May 1974, 18 pp.
11. Stachura, V. J., D. E. Siskind, and A. J. Engler. Airblast Instrumentation and Measurement Techniques for Surface Mine Blasting. BuMines RI 8508, 1981, 53 pp.
12. Stagg, M. S., and A. J. Engler. Measurement of Blast-Induced Ground Vibrations and Seismograph Calibration. BuMines RI 8506, 1980, 62 pp.
13. Winzer, S. R. The Firing Times of MS Delay Blasting Caps and Their Effect on Blasting Performance. Prepared for National Science Foundation (NSF APR 77-05171). Martin Marietta Laboratories (Baltimore, MD), June 1978, 36 pp.; available for consultation at Bureau of Mines Twin Cities Research Center, Minneapolis, MN.



## Chapter 6.—BLASTING SAFETY

The following is a discussion of good, safe blasting procedures, moving chronologically from initial explosive storage through postshot safety measures. In addition to these procedures, the blaster must familiarize himself or herself with all the safety regulations which govern his or her operation. These safety regulations contain additional advice on safe operating procedures for all phases of the blasting operation. The safety procedures discussed here are not meant to be, nor should be

considered to be, a substitute for adherence to safety regulations. Of course, all general workplace safety recommendations also apply to blasting activities.

The Institute of Makers of Explosives (IME) has published an excellent series of safety publications (5-13).<sup>1</sup> The National Fire Protection Association (NFPA) has published recommendations on the storage and handling of ammonium nitrate and blasting agents (14-16).

### EXPLOSIVES STORAGE

The Bureau of Alcohol, Tobacco and Firearms (BATF) regulates explosive importation, manufacture, distribution and storage, including proper recordkeeping to protect the public from misuse. Safe storage of explosives in the mining industry, including BATF regulations, is enforced by the Mine Safety and Health Administration (MSHA). In all other industries, safe explosive storage is regulated by BATF and the Occupational Safety and Health Administration (OSHA). In addition, most States, and many county and local government agencies, enforce their own explosive safety regulations.

Magazines for explosive storage must conform to specifications laid down by BATF and MSHA or OSHA. IME Pamphlet No. 1 (13) gives recommended standards for magazine construction. Magazines must be separated from each other, surrounding buildings, and rights-of-way according to the American Table of Distances [IME Pamphlet No. 2 (5)]. Separation distance requirements between ammonium nitrate and blasting agent storage facilities are less than for high explosives. However, the distance requirements for separation of blasting agents and ammonium nitrate from occupied structures and rights-of-way are the same as those for high explosives. Detonators may not be stored with other explosive materials. High explosives must be stored in a type 1 (BATF) or type 2 magazine. Blasting agents may be stored in a type 1 magazine with high explosives. When explosives and blasting agents are stored together, all of the material in the magazine is considered to be high explosives for separation distance purposes. Blasting agents may be stored in any approved magazine.

Except when explosives are being deposited or withdrawn, magazines must be kept locked. Only authorized personnel should deposit or withdraw explosives. The number of authorized persons should be kept to a minimum for both safety and security purposes. In this way accountability problems can be minimized. Explosive stocks should be piled neatly (fig. 99) to facilitate safe handling, and the oldest explosives should be used first to assure freshness. This is important for all explosive materials but especially for AN-FO, to prevent fuel segregation or evaporation. Segregation and evaporation of fuel from AN-FO is a particular problem in bulk storage (fig. 100).

Prolonged storage should be avoided. Good housekeeping standards should be maintained both inside and outside the magazine. To minimize the fire hazard, vegetation outside the magazine, except live trees over 10 ft high, should be cleared for a distance of at least 25 ft and rubbish should be cleared for at least 50 ft. Smoking or flames are not permitted in or within 50 ft of an outdoor storage magazine. Magazines should be clearly marked. The IME recommends a sign stating "Explosives—Keep Off" in 3-in-high letters with a ½-in brush stroke. It is advisable that the explosives sign be placed so that a bullet passing through the sign will not strike the magazine.

Primed explosives must never be stored in magazines. Misfired explosives should be disposed of immediately or stored in a separate magazine while awaiting disposal assistance. Assistance in disposing of deteriorated or unwanted explosives will be provided by the explosives distributor upon request.

### TRANSPORTATION FROM MAGAZINE TO JOBSITE

If the route from the magazine to the jobsite leaves company property, the transporter is subject to all State and local transportation regulations regarding vehicle specifications, placarding, and other operational procedures.

Explosive transportation should be done only in an approved vehicle in good repair and especially outfitted for the job. The practice of using the most conveniently available vehicle for explosive transportation should be avoided. The interior of the explosives compartment must be constructed of nonsparking material. If detonators are to be hauled on the same vehicle as explosives, they must be properly separated. MSHA regulations require a minimum separation by 4-in hardwood or the equivalent. Detonators should be protected from electrical contact. Adequate fire fighting equipment should be kept on

the vehicle at all times. Small fires that are clearly isolated from the explosive cargo should be fought. However, if fire reaches the explosive cargo, the vehicle should be abandoned and guarded at a safe distance because it may detonate.

The operator of the explosives vehicle should be well trained in both driving and explosives handling. Before moving out with the explosives load, the driver should make sure that the explosives cannot fall from the vehicle as frictional impact will readily initiate explosives. Explosives transport by rail and track equipment is particularly susceptible to the frictional impact hazard.

<sup>1</sup>Italicized numbers in parentheses refer to items in the list of references at the end of this chapter.



Figure 99.—Proper stacking of explosives. (Courtesy Austin Powder Co.)

At the jobsite, the explosives should be stored in a safe location, away from traffic if possible. The blast area should be delineated with cones or cordoned off, and unauthorized persons should not be permitted within this area. Where appropriate,

the explosives should be stored in an approved day magazine. Explosives should not be stored where they can be hit by falling rock or working equipment. Explosives should be under constant surveillance whenever they are not in a magazine.

## PRECAUTIONS BEFORE LOADING

Before any loading activities are started, the blast area must be clearly marked with flags, cones, or other readily identifiable markers. All unnecessary equipment must be removed from this area. All persons not essential to the powder loading operation should leave. Observers should be under the control of a responsible person who will assure that they do not create a hazard by wandering about the area. Any electrical power that might create a hazard should be disconnected. Where electric blasting is being used and the presence of

extraneous electricity is suspected, appropriate checks should be made with a blasters' multimeter (7) or a continuous ground current monitor should be utilized. Where extraneous electricity problems persist, a nonelectric initiation system should be used. Two-way radios in the near vicinity should be turned off when electric blasting is being used. IME Pamphlet No. 20 (10) gives safe transmitter distances as a function of the type and power of the transmitter.

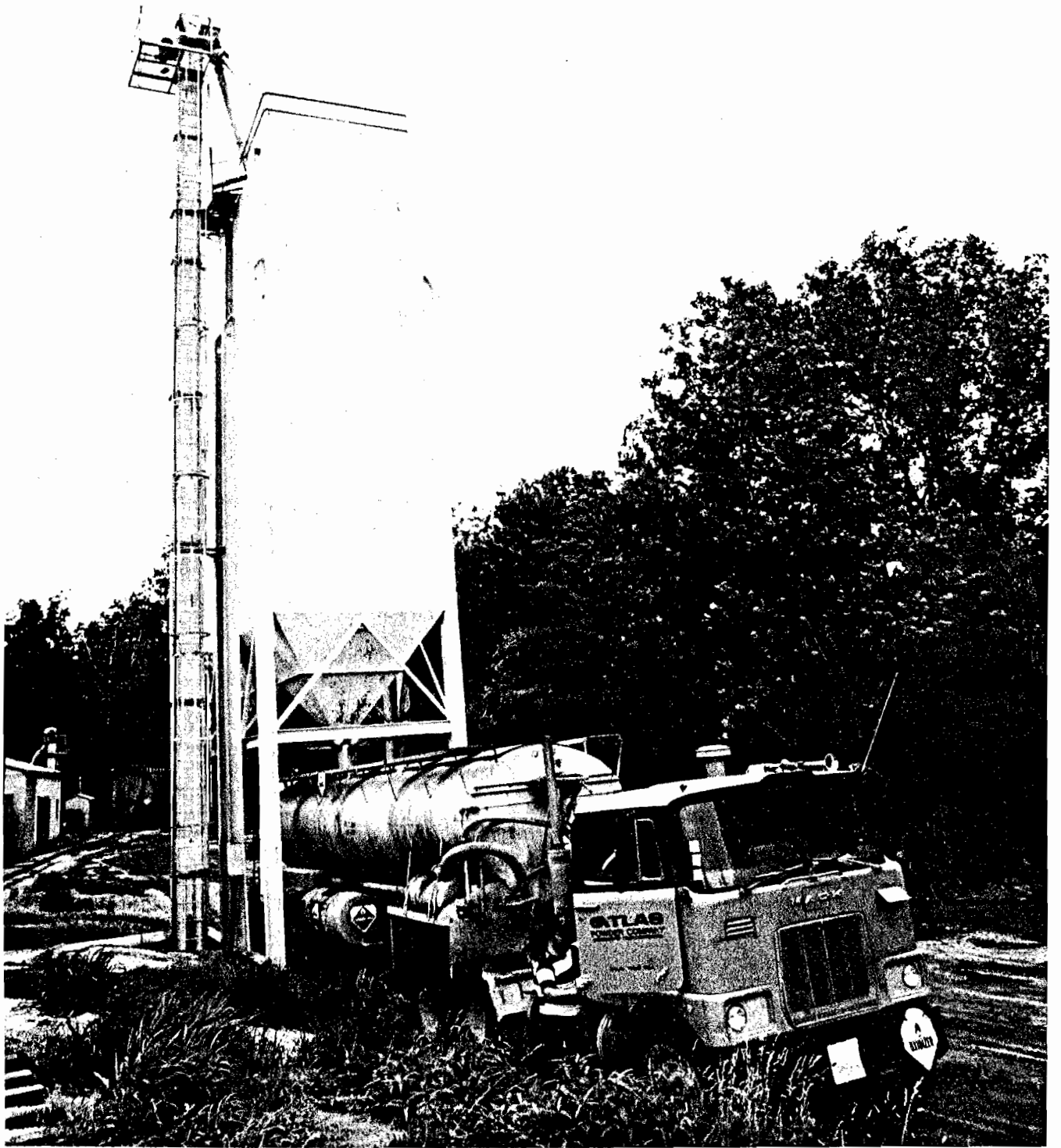

Figure 100.—AN-FO bulk storage facility. (Courtesy Atlas Powder Co.)

## PRIMER PREPARATION

It is a cardinal rule that primers be made up at the working face or as close to it as possible. The detonators and primer cartridges or cast primers should be brought in as separate components. The preparation of primers at a remote location and their transportation to the jobsite presents an undue hazard on the transportation route and should be permitted only where required by extenuating circumstances. In large tunnel projects, use of an outside primer makeup facility is often considered safer than making the primers at the face. All unused primers should be dismantled before removing them from the jobsite. Assembled primers containing detonators should never be stored.

A nonsparking tool should be used to punch the hole in the cartridge for cap placement. To assure control, the number of persons making up primers should be as few as practical. Electric hazards should be checked for if electric caps are being used. It is extremely important that the cap be fully imbedded into the cartridge and attached in such a way that it will not be dislodged when tension is put on the wires or tubes. A hard cartridge should not be rolled for softening. This will destroy the integrity of the cartridge and the cap may not stay fully imbedded. A good nonsparking powder punch should make an adequate hole in any cartridge without rolling it. The dangers of the cap falling out of the cartridge are twofold: (1) The cap may be struck during loading or tamping operations and cause a premature detonation, or (2) the cap may fail to initiate the primer when it is activated. When using electric caps with small-diameter explosive cartridges, the cartridge

should be punched at the end for cap insertion and the leg wires should be fastened to the cartridge by a half hitch to remove the possibility of tension on the cap (fig. 49).

The structure of larger cartridges may require punching the cap hole in the side. With cast primers, the cap is passed through the channel and into the cap well (fig. 50). The leg wires may be taped to the cast primer for extra security. Primer preparation for other types of blasting caps, such as Nonel,<sup>2</sup> Primadet, and Hercudet, is similar to that for electric blasting caps. However, because propagation through the tubing of some of these products may be hampered by sharp bends, taping the tubing to the cartridge is recommended rather than half hitching. The manufacturer should be consulted for recommendations.

Where detonating cord is connected directly to the primer cartridge, it should be secured with a tight knot, supplemented by half hitches. With a cast primer, detonating cord is passed through the channel and a knot is tied at the end of the cord to keep the primer from slipping off. Subsequent primers can be slid down the detonating cord. When using cap and fuse, a diagonal hole is made through the cartridge. The cap and fuse are passed through this hole and into a second hole made for cap emplacement. Sometimes the cap is placed into a single, diagonally placed side hole and the fuse is tied to the cartridge with string. With fuse that will withstand a 180° bend, end priming, similar to that used with electric blasting caps, may be used. Cast primers are not normally used with cap and fuse.

## BOREHOLE LOADING

Before loading begins, the area should be doublechecked for unnecessary personnel and equipment. If electric caps are being used, possible electrical hazards should be double-checked. If an electrical storm approaches at any time when explosives are present, the area must be vacated, regardless of whether electric detonators are being used. Weather reports, lightning detectors, or even static from AM radio receivers may serve as warning of approaching electrical storms. Before any detonators or explosives are brought into the blast area, all circuits in the immediate vicinity should be deenergized.

Before loading begins, each borehole should be checked for proper depth. This will help prevent excessive column buildup, resulting in inadequate stemming and excessive flyrock. In most situations, holes that are too deep should be partially backfilled. Short holes may require cleaning or redrilling.

Using a weighted tape, the column buildup should be checked frequently during loading. With relatively short, small-diameter holes, a tamping pole can be used to check the depth and also to check for blockages. If the buildup is less than anticipated, this may result in a cavity packed full of explosive which may blow out violently when detonated. If the column builds up more quickly than expected, frequent checking will prevent overloading. Proper stemming length is described in the "Blast Design" chapter. As a general rule of thumb, the stemming should be 14 to 28 borehole diameters.

When loading small-diameter cartridges, a nonsparking tamping pole should be used. Although there are differences of opinion, there is a consensus that a cushion stick should not

be used in small-diameter holes; therefore, the primer should be the first cartridge placed into the hole. The base of the cap should point toward the collar. The primer cartridge should never be slit and should be pushed into place firmly. It should never be tamped vigorously. Two or three cartridges may then be slit, placed as a column, and tamped firmly. The remaining cartridges may be slit and tamped firmly. Excessive tamping should never be done. Care should be taken not to damage the detonator's leg wires or tubes.

Cartridges are often loaded in large-diameter blastholes by dropping them down the hole. However, the primer cartridge and a cartridge or two above the primer should be lowered to prevent damage to the primer. Leg wires or tubes from detonators may also be prone to damage from dropped cartridges. "Wet bags" of AN-FO should not be dropped. They depend on the cartridge material for water resistance, and dropping them may break the package and cause water leakage and subsequent desensitization of the AN-FO. A potential problem in bulk loading of large diameter blastholes is overloading. Here it is especially important to check the column rise frequently as loading progresses (fig. 101).

When pneumatically loading blastholes with pressure pots or venturi loaders, over electric blasting cap leg wires, it is essential that the loader be properly grounded to prevent buildup of static electricity. This grounding should not be to

<sup>2</sup>Reference to specific trade names does not imply endorsement by the Bureau of Mines.



Figure 101.—Checking the rise of the AN-FO column with a weighted tape.



pipes, air lines, rails, or other fixtures that are good conductors of stray current. Extraneous electricity is also a potential hazard with nonelectric detonators. Plastic liners should not be used when pneumatically loading small blastholes, as this increases the chance for static buildup. This is particularly hazardous with electric detonators. A semiconductive loading hose with a minimum resistance of 1,000 ohms/ft and 10,000 ohms total resistance, and a maximum total resistance of

2,000,000 ohms should be used. Such a hose will permit a static charge to bleed off but will not allow stray currents to enter the borehole. Where extraneous electricity is a problem, or where it is illegal to load pneumatically over leg wires, a nonelectric initiation system should be used. This does not entirely eliminate the hazard, so the safeguards mentioned previously should still be followed.

## HOOKING UP THE SHOT

The size of crew used to hook up the shot should be kept to an absolute minimum. A single person should be in charge of final checkout to assure that the hookup plan has been properly followed and that the blast is ready to fire.

When blasting electrically, the series circuit is the easiest, safest, and surest. If several shots are to be fired together, or if there is an excessive number of caps in one shot, a parallel series circuit should be used. Make sure that each series has the same resistance. A twisted loop is the best connection for two relatively light gage wires. Splices for connecting light gage wire to heavy gage wires are shown in figure 22. Excessive wire between holes may be coiled or removed for neatness and to facilitate visual inspection of the circuit. Make sure that bare connections do not touch each other or the ground in order to avoid short circuits, current leakage, or picking up of extraneous currents.

After each portion of the circuit has been hooked up, check for continuity and proper resistance with a blasting multimeter or galvanometer. The circuit should then be shunted until ready for the final hookup prior to blasting. It is especially important that the lead wire be kept shunted at the shotfirer's location until the blast is ready to be fired.

A blasting machine is recommended for firing all shots. If a powerline is used it should be one that is specifically dedicated to blasting and is equipped with a safeguard against overenergizing the caps and against the resulting arcing. Batteries should never be used for firing electrical blasting circuits because their output is unpredictable and may cause only a portion of the round to be fired. Parallel circuits are less desirable because they require high current and cannot be checked for shorts or broken wires. If powerline firing or straight parallel circuits are necessary, the cap manufacturer should be consulted for procedures for minimizing problems.

When firing with detonating cord systems, make sure the

knots are tight and secure. Tight lines and severe angles between lines should be avoided (fig. 32). The cord should not be permitted to cross itself. The cord circuit should be laid out so that each hole can be initiated by at least two paths from the detonator used to initiate the circuit. After the hookup has been completed, the circuit should be carefully checked visually by the person in charge of the blast. The initiating cap should not be connected to the detonating cord until it is time to blast.

When blasting with fuse, the use of Ignitacord is recommended for multiple hole blasts. A principal cause of fuse accidents is trying to light too many fuses at one time. Secondary causes are wet or deteriorated fuse and insufficient or improper lighting equipment. When using Ignitacord, all fuses should be the same length. The path of the Ignitacord will determine the delay sequence. The Ignitacord should not cross itself, because crosslighting is a possibility. At least two persons must be present when lighting fuses. If fuses are being individually lit, no person shall light more than 15 fuses. MSHA regulations specify burning times for fuses, depending on the number of fuses a person lights. The burning speed of fuse should be tested frequently. All fuse burns nominally at about 40 sec/ft. All fuses must be burning inside the hole before the first hole detonates.

Accident rates show that fuse blasting is inherently more hazardous than other initiation methods. Many of these incidents occur with highly experienced miners. It is recommended that, wherever practical, fuse blasting be replaced by an alternative initiation system. When using the more recently developed initiation systems such as Hercudet, Detaline, and Nonel, the blaster should seek advice on the proper hookup procedures from the manufacturer or distributor. Certain aspects of these systems are still evolving and recommended procedures change from time to time.

## SHOT FIRING

More people are injured and killed during the shot firing operation than any other phase of blasting. This is usually due to inadequate guarding, improper signaling, or some other unsafe practice that permits a person to be too close to the blast when it is detonated. It is essential that the blaster take positive steps to assure that no one, including the blaster and the crew, is in the area of potential flyrock at the time of detonation.

The blaster should allow adequate time immediately before blasting to inspect the blast area for any last minute problems. He or she should have a fail-safe system to assure that the blast is not inadvertently fired. This can be done by safeguard-

ing the key or handle to the blasting machine or switch. While proceeding from the loaded shot toward the shotfiring location, the blaster should make sure that all connections between the blasting circuit and the firing mechanism are intact.

The blaster must make sure that there are enough guards to seal off the area and protect persons from inadvertently proceeding into the blast area. It is common procedure to block access to the blast zone 5 to 10 min before the blast. The guards should proceed outward from the blast area, clearing all personnel from the area as they proceed. They should take up guard positions beyond the range of flyrock, concussion, and toxic gases. Once the area has been sealed off, the

guards must permit no one to pass unless they first inform the shotfirer and receive assurance from the shotfirer that he or she will postpone the blast.

A warning siren with an audible range of about 0.5 mi should be sounded before the blast. However, signs or audible warnings alone are not dependable for keeping people out of the blast area. These types of warning may not be understood by all persons in the area and they do not clearly delineate the hazardous area. Many underground mines have check-in and checkout procedures that are used to assure that no one will stray into the blast area. These systems reduce the number of guards required. The guards must be told if more than one blast is to be fired. Even after all blasts have been fired, it is important that the guards receive an audible or visual all-clear signal before allowing persons to pass. If the guard is in doubt, he or she should keep the area secure until the doubt is removed.

The shotfirer should choose a safe firing location with adequate distance and/or cover (fig. 102) for protection from flyrock, concussion, and toxic gases. Ideally he or she should have two-way visual or audible contact with the guards. On a surface blast the shotfiring location should command a good view of the area surrounding the blast. Just before the shotfiring

mechanism is prepared for activation the blaster should alert the guards to seal off the area and should receive a positive response from each guard. Immediately before firing the shot guards are again alerted and if their response is positive, the shot is fired. If the shot fails to fire, security must be maintained while the blaster attempts to correct the problem. Once security is removed, the entire guarding procedure should be repeated before the shot is fired.

In some situations, particularly underground, contact between the shotfirer and the guards may be impractical. In this case, the guards must clear and secure the area and maintain security until all shots are fired or until they are relieved of the responsibility by the blaster. This may mean guarding the area for an extended period of time.

Obviously some situations will exist which will not fit the preceding discussion. The principles, however, will remain the same—(1) the blast area must be cleared and guarded and (2) security must be maintained until it is certain that the blasting activities in the area have ceased for the time in question.

Blasting at night at surface mines is especially hazardous because of the lack of visibility and should be done only in an emergency.



Figure 102.—Blasting shelter. (Courtesy Hercules Inc.)

## POSTSHOT SAFETY

At least 15 sec should be allowed for all flyrock to drop. Even after all flyrock has subsided, the hazards of toxic gases and loose rock in the blast area exist. The area should not be reentered until the toxic gases have been dispersed. The time required for this may range from a minute for surface blasting to an hour or more for a poorly ventilated underground opening. In case of a known or suspected misfire, a waiting period of at least 30 min with cap-and-fuse blasting or at least 15 min with electric initiation systems must be observed. If explosives are suspected to be burning in a blasthole, a 1-hr minimum waiting period must be observed. The practice of blasting between shifts is recommended because it avoids or minimizes guarding problems and allows gases to clear before reentry.

The first person reentering the blast area should inspect the area for loose rock that poses a hazard to personnel. The area should be dangered off until any loose rock has been barred down or otherwise taken care of. The blast area should be checked for misfires. Loose explosives or detonating cord in the muckpile often indicate a misfire. Leg wires, detonating cord, or tubes extending from a borehole may indicate a misfire. Another indicator is an area of the blast that has not broken or pulled properly or an unusual shape of the muckpile. In many cases this takes the form of an unusually long bootleg. Because a misfire is not always obvious, a trained eye is often required to detect one. Other persons must not be permitted into the blast area until it is certain that no hazards exist.

## DISPOSING OF MISFIRES

A good method of misfire disposal is to remove the undetonated charge by water flushing or air pressure. Horizontal or shallow holes are most amenable to this technique. It is important to visually inspect the hole using a light source to assure that all of the charge has been removed.

Where removal of the misfired charge is too difficult, an alternative is to detonate the charge. If leg wires, tubes, or detonating cord are protruding from the holes, and they are intact, they may be reconnected and fired. If this cannot be done, the stemming may be removed, a new primer inserted at the top of the powder column, and the hole refired. Caution must be exercised in refiring misfired holes from which much of the burden has been removed. Excessive flyrock is likely to result and the area must be guarded accordingly. If neither of

these alternatives are feasible, the charge will have to be dug out. First, the hole should be flooded with water to desensitize any non-water-resistant explosive present. Next, the rock surrounding the misfire is dug out carefully, with an observer present to guide the excavator. Extreme discretion must be exercised in this operation.

The practice of drilling and shooting a hole adjacent to the misfire has been used, but can be extremely hazardous. People have been killed using this technique when the new hole intersected the misfired hole and detonated it. All of the previously described techniques are preferable to drilling an adjacent hole. MSHA metal-nonmetal regulations prohibit drilling a hole where there is a danger of intersecting a charged or misfired hole.

## DISPOSAL OF EXPLOSIVE MATERIALS

For years the method recommended by the IME for destroying explosives was burning. However, the recent proliferation of nonflammable explosive products has caused the IME to withdraw this recommendation and its pamphlet that described

proper burning techniques. The recommendation now made by the IME is to contact the nearest explosive distributor, whether or not it handles the brand of explosive in question. The distributor should dispose of the unwanted explosive.

## PRINCIPAL CAUSES OF BLASTING ACCIDENTS

Although there is a potential for serious accidents at every stage of explosive use, certain aspects of blasting have more accident potential than others. Case history articles describing typical blasting accidents have been written (2-3). Avoiding the following four types of accidents, listed in approximate order of frequency, would significantly improve the safety record of the blasting industry.

**Improper Guarding.** This includes improper guarding of the blast area or blasting crew members taking inadequate cover. Many people underestimate the potential range of flyrock.

**Impacting Explosives.** Most often this involves drilling into holes containing explosives, frequently bootlegs. However, it may involve striking explosives with excavator buckets, tracked

equipment, or rail equipment, or excessive beating on explosives with a tamping pole.

**Unsafe Cap and Fuse Practices.** For various reasons, all involving unsafe acts or carelessness, the blaster is still in the vicinity of the blast when it detonates.

**Extraneous Electricity.** Exposure of electric blasting caps to stray ground current, static buildup, radiofrequency energy, inductive coupling, or improper test instruments can cause unscheduled detonation. Lightning is a hazard with all types of explosive materials.

Other causes of accidents include explosive fires that detonate (hangfires), poor warning systems, loading hot holes, and exposure to blast fumes.

## UNDERGROUND COAL MINE BLASTING

All underground coal mine blasting is done electrically. The foregoing discussion applies to underground coal mine blasting. There are additional hazards caused by the potentially explosive atmosphere present in underground coal mines. Both methane and coal dust present an explosion hazard. As a result, underground coal mine blasters must undergo rigorous,

specialized training before they can become qualified shotfirers. Because of its specificity, a discussion of underground coal mine blasting safety is beyond the scope of this manual. An excellent pocket-size pamphlet (4) is available from Hercules, Inc., which gives recommended procedures for underground coal mine shotfirers.

## REFERENCES

1. Atlas Powder Co. (Dallas, TX). Handbook of Electric Blasting. Rev. 1976, 93 pp.
2. Dick, R. A., and J. G. Gill. Metal and Nonmetal Mine Blasting Accidents During 1975-1976. *Min. Eng.*, v. 29, No. 11, November 1977, pp. 36-39.
3. \_\_\_\_\_. Recent Blasting Fatalities in Metal-Nonmetal Mining. *Pit and Quarry*, v. 67, No. 12, June 1975, pp. 85-87.
4. Hercules, Inc. (Wilmington, DE). Shotfirer's Guide. 1978, 12 pp.
5. Institute of Makers of Explosives Safety Library (Washington, DC). The American Table of Distances. Pub. No. 2, April 1977, 17 pp.
6. \_\_\_\_\_. Do's and Don'ts Instructions and Warnings. Pub. No. 4, Rev. July 11, 1978, 12 pp.
7. \_\_\_\_\_. Glossary of Industry Terms. Pub. No. 12, September 1981, 28 pp.
8. \_\_\_\_\_. IME Standard for the Safe Transportation of Electric Blasting Caps in the Same Vehicle With Other Explosives. Pub. No. 22, Mar. 21, 1979, 8 pp.
9. \_\_\_\_\_. Recommended Industry Safety Standards. Pub. No. 6, Feb. 1977, 46 pp.
10. \_\_\_\_\_. Safety Guide for the Prevention of Radio-Frequency Radiation Hazards in the Use of Electric Blasting Caps. Pub. No. 20, October 1978, 20 pp.
11. \_\_\_\_\_. Safety in the Transportation, Storage, Handling, and Use of Explosives. Pub. No. 17, April 1974, 57 pp.
12. \_\_\_\_\_. Suggested Code of Regulations for the Manufacture, Transportation, Storage, Sale, Possession and Use of Explosive Materials. Pub. No. 3, May 1980, 59 pp.
13. \_\_\_\_\_. Typical Storage Magazines. Pub. No. 1, October 1977, 22 pp.
14. National Fire Protection Association (Boston, MA). Manufacture, Storage, Transportation and Use of Explosives and Blasting Agents—1973. Pamphlet 495, 1973, 69 pp.
15. \_\_\_\_\_. Separation of Ammonium Nitrate Blasting Agents From Explosives—1976. Pamphlet 492, 1976, 10 pp.
16. \_\_\_\_\_. Storage of Ammonium Nitrate—1975. Pamphlet 490, 1975, 22 pp.

## BIBLIOGRAPHY

1. Andrews, A. B. Design of Blasts. Emphasis on Blasting. Ensign Bickford Co. (Simsbury, CN), Spring 1980, pp. 1, 4.
2. Ash, R. L. The Mechanics of Rock Breakage, Parts I, II, III, and IV. Pit and Quarry, v. 56, No. 2, August 1963, pp. 98-112; No. 3, September 1963, pp. 118-123; No. 4, October 1963, pp. 126-131; No. 5, November 1963, pp. 109-111, 114-118.
3. Atlas Powder Co. (Dallas TX). Handbook of Electric Blasting. Rev. 1976, 93 pp.
4. \_\_\_\_\_. Pneumatic Loading of Nitro-Carbo-Nitrates; Static Electricity, Fumes, and Safe Handling. Undated, 17 pp.
5. Bauer, A., and J. W. Sanders. Good Blasting Techniques and Public Relations. Min. Cong. J., v. 54, No. 11, November 1968, pp. 81-85.
6. Chironis, N. P. New Blasting Machine Permits Custom-Programmed Blast Patterns. Coal Age, v. 79, No. 3, March 1974, pp. 78-82.
7. Condon, J. L., and J. J. Snodgrass. Effects of Primer Type and Borehole Diameter on AN-FO Detonation Velocities. Min. Cong. J., v. 60, No. 6, June 1974, pp. 46-47, 50-52.
8. Cook, M. A. Explosives—A Survey of Technical Advances. Ind. and Eng. Chem., v. 60, No. 7, July 1968, pp. 44-55.
9. \_\_\_\_\_. The Science of Industrial Explosives. Ireco Chemicals, Salt Lake City, UT, 1974, 449 pp.
10. Damon, G. H., C. M. Mason, N. E. Hanna, and D. R. Forshey. Safety Recommendations for Ammonium Nitrate-Based Blasting Agents. BuMines IC 8746, 1977, 31 pp.
11. Dannerberg, J. Blasthole Dewatering Cuts Costs. Rock Products, v. 76, No. 12, December 1973, pp. 66-68.
12. \_\_\_\_\_. How To Solve Blasting Materials Handling Problems. Rock Products, v. 74, No. 9, September 1971, pp. 63-65.
13. Dick, R. A. Explosives and Borehole Loading. Subsection 11.7, SME Mining Engineering Handbook, ed. by A. B. Cummins and I. A. Given, Society of Mining Engineers of the American Institute of Mining, Metallurgical, and Petroleum Engineers, Inc., New York, v. 1, 1973, pp. 11-78—11-99.
14. \_\_\_\_\_. Factors in Selecting and Applying Commercial Explosives and Blasting Agents. BuMines IC 8405, 1968, 30 pp.
15. \_\_\_\_\_. The Impact of Blasting Agents and Slurries on Explosives Technology. BuMines IC 8560, 1972, 44 pp.
16. \_\_\_\_\_. New Nonelectric Explosive Initiation Systems. Pit and Quarry, v. 68, No. 9, March 1976, pp. 104-106.
17. \_\_\_\_\_. Puzzled About Primers for Large Diameter AN-FO Charges? Here's Some Help To End the Mystery. Coal Age, v. 81, No. 8, August 1976, pp. 102-107.
18. \_\_\_\_\_. A Review of the Federal Surface Coal Mine Blasting Regulations. Proc. 5th Conf. on Explosives and Blasting Technique, St. Louis, MO, Feb. 7-9, 1979. Society of Explosives Engineers, Montville, OH, pp. 1-7.
19. Dick, R. A., and J. G. Gill. Metal and Nonmetal Mine Blasting Accidents During 1975-1976. Min. Eng., v. 29, No. 11, November 1977, pp. 36-39.
20. \_\_\_\_\_. Recent Blasting Fatalities in Metal-Nonmetal Mining. Pit and Quarry, v. 67, No. 12, June 1975, pp. 85-87.
21. Dick, R. A., and J. J. Olson. Choosing the Proper Borehole Size for Bench Blasting. Min. Eng., v. 24, No. 3, March 1972, pp. 41-45.
22. Dick, R. A., and D. E. Siskind. Ground Vibration Technology Pertaining to OSM Regulations. Proc. Symp. on Surface Coal Mining and Reclamation, Coal Conf. & Expo, Louisville, KY, Oct. 23-25, 1979. McGraw-Hill, New York, pp. 13-18.
23. Drury, F., and D. J. Westmaas. Considerations Affecting the Selection and Use of Modern Chemical Explosives. Proc. 4th Conf. on Explosives and Blasting Technique, New Orleans, LA, Feb. 1-3, 1978. Society of Explosives Engineers, Montville, OH, pp. 128-153.
24. E. I. duPont de Nemours & Co., Inc. (Wilmington, DE). Blaster's Handbook. 16th ed., 1978, 494 pp.
25. \_\_\_\_\_. Four Major Methods of Controlled Blasting. 1964, 16 pp.
26. Ensign Bickford Co. (Simsbury, CN). Primacord Detonating Cord. 9th printing, copyright 1963, 68 pp.
27. Friend, R. C. Explosives Training Manual. ABA Publishing Co., Wilmington, DE, 1975, 212 pp.
28. Grant, C. H. Metallized Slurry Boosting: What It Is and How It Works. Coal Age, v. 71, No. 4, April 1966, pp. 90-91.
29. Gregory, C. E. Explosives for North American Engineers. Trans Tech Publications, Rockport, MA, 1979, 303 pp.
30. Gustaffson, R. Swedish Blasting Technique. SPI, Gothenburg, Sweden, 1973, 323 pp.; available for consultation at Bureau of Mines Twin Cities Research Center, Minneapolis, MN.
31. Hagan, T. N. Optimum Priming for Ammonium Nitrate Fuel-Oil Type Explosives. Proc. Southern and Central Queensland Conf. of the Australasian Inst. of Min. and Met., Parkville, Australia, July 1974, pp. 283-297; available for consultation at Bureau of Mines Twin Cities Research Center, Minneapolis, MN.
32. Hemphill, G. B. Blasting Operations. McGraw-Hill, New York, 1981, 258 pp.
33. Hercules, Inc. (Wilmington, DE). Shotfirer's Guide. 1978, 12 pp.
34. Institute of Makers of Explosives Safety Library (Washington, DC). The American Table of Distances. Pub. No. 2, April 1977, 17 pp.
35. \_\_\_\_\_. Do's and Don'ts Instructions and Warnings. Pub. No. 4, Rev. July 11, 1978, 12 pp.
36. \_\_\_\_\_. Glossary of Industry Terms. Pub. No. 12, September 1981, 28 pp.
37. \_\_\_\_\_. IME Standard for the Safe Transportation of Electric Blasting Caps in the Same Vehicle With Other Explosives. Pub. No. 22, Mar. 21, 1979, 8 pp.
38. \_\_\_\_\_. Recommended Industry Safety Standards. Pub. No. 6, February 1977, 46 pp.
39. \_\_\_\_\_. Safety Guide for the Prevention of Radio-Frequency Radiation Hazards in the Use of Electric Blasting Caps. Pub. No. 20, October 1978, 20 pp.
40. \_\_\_\_\_. Safety in the Transportation, Storage, Handling, and Use of Explosives. Pub. No. 17, April 1974, 57 pp.
41. \_\_\_\_\_. Suggested Code of Regulations for the Manufacture, Transportation, Storage, Sale, Possession and Use of Explosive Materials. Pub. No. 3, May 1980, 59 pp.
42. \_\_\_\_\_. Typical Storage Magazines. Pub. No. 1, October 1977, 22 pp.
43. Johansson, C. H., and U. Langefors. Methods of Physical Characterization of Explosives. Proc. 36th Internat. Cong. of Ind. Chem., Brussels, v. 3, 1966, p. 610; available for consultation at Bureau of Mines Twin Cities Research Center, Minneapolis, MN.
44. Junk, N. M. Overburden Blasting Takes on New Dimensions. Coal Age, v. 77, No. 1, January 1972, pp. 92-96.
45. \_\_\_\_\_. Research on Primers for Blasting Agents. Min. Cong. J., v. 50, No. 4, April 1964, pp. 98-101.
46. Langefors, U., and B. A. Kihlstrom. The Modern Technique of Rock Blasting. John Wiley & Sons, Inc., New York, 1963, 405 pp.
47. Lundborg, N., P. A. Persson, A. Ladegaard-Pederson, and R. Holmberg. Keeping the Lid on Flyrock From Open Pit Blasting. Eng. and Min. J., v. 176, No. 5, May 1975, pp. 95-100.
48. Miller, P. Blasting Vibration and Airblast. Atlas Powder Co. (Dallas, TX), 16 pp.
49. Monsanto Co. (St. Louis, MO). Monsanto Blasting Products AN-FO Manual. Its Explosive Properties and Field Performance Characteristics. September 1972, 37 pp.
50. National Fire Protection Association (Boston, MA). Manufacture, Storage, Transportation and Use of Explosives and Blasting Agents—1973. Pamphlet 495, 1973, 69 pp.
51. \_\_\_\_\_. Separation of Ammonium Nitrate Blasting Agents From Explosives—1976. Pamphlet 492, 1976, 10 pp.
52. \_\_\_\_\_. Storage of Ammonium Nitrate—1975. Pamphlet 490, 1975, 22 pp.
53. Nicholls, H. R., C. F. Johnson, and W. I. Duvall. Blasting Vibrations and Their Effects on Structures. BuMines B 656, 1971, 105 pp.
54. Porter, D. D. Use of Fragmentation To Evaluate Explosives for Blasting. Min. Cong. J., v. 60, No. 1, January 1974, pp. 41-43.

55. Pugliese, J. M. Designing Blast Patterns Using Empirical Formulas. BuMines IC 8550, 1972, 33 pp.
56. Robinson, R. V. Water Gel Explosives—Three Generations. Canadian Min. and Met. Bull., v. 62, No. 692, December 1969, pp. 1317-1325.
57. Schmidt, R. L., R. J. Morrell, D. H. Irby, and R. A. Dick. Application of Large-Hole Burn Cut in Room-and-Pillar Mining. BuMines RI 7994, 1975, 25 pp.
58. Sengupta, D., G. French, M. Heydari, and K. Hanna. The Impact of Eliminating Safety Fuse From Metal/Nonmetal Mines (Contract J0295010, Sci. Applications, Inc.). BuMines OFR 61-81, August 1980, 11 pp.; NTIS PB 81-214386.
59. Siskind, D. E., V. J. Stachura, M. S. Stagg, and J. W. Kopp. Structure Response and Damage Produced by Airblast From Surface Mining. BuMines RI 8485, 1980, 111 pp.
60. Siskind, D. E., M. S. Stagg, J. W. Kopp, and C. H. Dowding. Structure Response and Damage Produced by Ground Vibration From Surface Mine Blasting. BuMines RI 8507, 1980, 74 pp.
61. Siskind, D. E., and C. R. Summers. Blast Noise Standards and Instrumentation. BuMines TPR 78, May 1974, 18 pp.
62. Stachura V. J., D. E. Siskind, and A. J. Engler. Airblast Instrumentation and Measurement Techniques for Surface Mine Blasting. BuMines RI 8508, 1981, 53 pp.
63. Stagg, M. S., and A. J. Engler. Measurement of Blast-Induced Ground Vibrations and Seismograph Calibration. BuMines RI 8506, 1980, 62 pp.
64. U. S. Bureau of Mines. Apparent Consumption of Industrial Explosives and Blasting Agents in the United States, 1981. Mineral Industry Survey, June 23, 1982, 12 pp.
65. U. S. Department of the Treasury; Bureau of Alcohol, Tobacco and Firearms. Explosive Materials Regulations. Federal Register, v. 42, No. 149, Aug. 3, 1977, pp. 39316-39327; Federal Register, v. 45, No. 224, Nov. 18, 1980, pp. 76191-76209.
66. U. S. Mine Enforcement and Safety Administration. Active List of Permissible Explosives and Blasting Devices Approved Before Dec. 31, 1975. MESA Inf. Rep. 1046, 1976, 10 pp.
67. U. S. Office of Surface Mining. Surface Coal Mining and Reclamation Operations-Permanent Regulatory Program. Federal Register, v. 44, No. 50, Mar. 13, 1979, Book 2, pp. 15404-15406 (regulations), Book 3, pp. 15179-15202 (preamble.)
68. Winzer, S. R. The Firing Times of MS Delay Blasting Caps and Their Effect on Blasting Performance. Prepared for National Science Foundation (NSF APR 77-05171). Martin Marietta Laboratories (Baltimore, MD), June 1978, 36 pp.; available for consultation at Bureau of Mines Twin Cities Research Center, Minneapolis, MN.

## APPENDIX A.—FEDERAL BLASTING REGULATIONS

Numerous aspects of the manufacture, transportation, storage, sale, possession, and use of explosives are regulated. These regulations may be enforced at the Federal, State, county, city, and township level of government. Some Federal regulations are enforced by State agencies. State and local agencies often adopt regulations that duplicate or expand upon Federal regulations. It is important that every person or company involved in handling explosives maintains a file of all the regulations that apply to the operation. This appendix discusses the regulation picture at the Federal level. The powder supplier will be able to direct the blaster to the other levels of government that enforce regulations in a particular geographic area. Where there is a conflict between two regulations in a geographic area, the most restrictive, or the one that provides the greatest degree of safety, should be complied with. Unfortunately, this interpretation is not always clear cut.

Federal agencies that are specifically chartered by the Code of Federal Regulations (CFR) to regulate blasting are—

1. Department of Labor
  - A. Mine Safety and Health Administration—CFR 30, Parts 1-199
  - B. Occupational Safety and Health Administration—CFR 29, Parts 1900-1999

2. Department of Interior, Office of Surface Mining Reclamation and Enforcement—CFR 30, Parts 700-999
3. Department of the Treasury, Bureau of Alcohol, Tobacco and Firearms—CFR 27, Parts 1-299
4. Department of Transportation
  - A. Research and Special Programs Administration—CFR 49, Parts 100-177
  - B. Federal Highway Administration—CFR 49, Parts 301-399

Table A-1 summarizes the responsibilities of these agencies. It is a good idea for the blaster to maintain copies of these regulations and to read them. There is a good possibility that some of the regulations a blaster may have on hand are out of date, because regulations change frequently. The Federal Register updates all the regulation changes on a daily basis. Codified regulations are updated and published on an annual basis. Also, some companies provide the service of keeping operators informed of changes in regulations.

**Table A-1. - Federal regulatory agency responsibility**

Department and agency	Primary responsibility	Source of regulations
Department of Labor: Mine Safety and Health Administration.	Onsite safety in the storage, transportation, and use of explosives in mining operations.	CFR 30, Chapter I: Subchapter C, Parts 15, 16, 17. Subchapter D, Parts 24, 25. Subchapter H, Part 48. Subchapter N, Parts 55, 56, 57. Subchapter O, Parts 75, 77
Occupational Safety and Health Administration.	Onsite safety in the storage, transportation, and use of explosives in construction and other nonmine blasting operations	CFR 29, Subtitle B, Chapter XVII: Part 1910, Subpart H. Part 1926, Subpart U.
Department of Interior: Office of Surface Mining Reclamation and Enforcement.	Environmental protection for surface blasting associated with coal mines.	CFR 30, Chapter VII: Subchapter K, Parts 816, 817
Department of Treasury: Bureau of Alcohol, Tobacco and Firearms.	Security in the importation, manufacture, distribution, and storage of explosives.	CFR 27, Part 181: Subparts A, B, C, D, E, F, G, H, I, J.
Department of Transportation: Research and Special Projects Administration.	Safe shipment of explosives in interstate commerce.	CFR 49, Chapter I, Subchapter C: Parts 171, 172, 173, 174, 175, 176, 177.
Federal Highway Administration.	...do .....	CFR 49, Chapter III, Subchapter B: Part 397.

## MINE SAFETY AND HEALTH ADMINISTRATION (MSHA)

MSHA regulates safety in the handling of explosives in all types of mining. Topics included are onsite storage, transportation from the magazine to the jobsite, and use. These regulations can be found in CFR 30, in the following parts:

- Chapter I—Mine Safety and Health Administration
- Subchapter C—Explosives and Related Articles; Tests for Permissibility and Suitability

- Part 15—Explosives and Related Articles (including permissible blasting practices)
- Part 16—Stemming Devices
- Part 17—Blasting Devices
- Subchapter D—Electrical Equipment, Lamps, Methane Detectors; Tests for Permissibility; Fees
- Part 24—Single-Shot Blasting Units

Part 25—Multiple-Shot Blasting Units  
 Subchapter H—Education and Training  
 Part 48—Training and Retraining of Miners  
 Subchapter N—Metal and Nonmetallic Mine Safety and Health  
 Part 55—Safety and Health Standards—Metal and Non-metallic Open Pit Mines  
 55.2 Definitions  
 55.6 Explosives  
 Part 56—Safety and Health Standards—Sand, Gravel, and Crushed Stone Operations  
 56.2 Definitions  
 56.6 Explosives  
 Part 57—Safety and Health Standards—Metal and Non-metallic Underground Mines

57.2 Definitions  
 57.6 Explosives  
 57.21 Gassy Mines; 57:21-95—57.21-101, Explosives

Subchapter O—Coal Mine Safety and Health  
 Part 75—Mandatory Safety Standards—Underground Coal Mines  
 Subpart N—Blasting and Explosives  
 Part 77—Mandatory Safety Standards, Surface Coal Mines and Surface Work Areas of Underground Coal Mines  
 Subpart N—Explosives and Blasting  
 Subpart T—Slope and Shaft Sinking

In many cases MSHA regulations are enforced by State agencies. Some States may have more stringent mine health and safety regulations than those of MSHA.

## OCCUPATIONAL SAFETY AND HEALTH ADMINISTRATION (OSHA)

OSHA is a companion agency of MSHA, both being in the Department of Labor. OSHA regulates safety in the handling of explosives in nonmining industries, most notably construction. The OSHA blasting regulations are found in CFR 29, in the following parts:

Subtitle B—Regulations Relating to Labor  
 Chapter XVII—OSHA, Department of Labor  
 Subpart H—Hazardous Materials

1910.109—Explosives and Blasting Agents  
 Part 1926—Safety and Health Regulations for Construction  
 Subpart U—Blasting and Use of Explosives (Sections 1926.900—1926.914)

In many cases, OSHA regulations are enforced by State agencies. Some States may have more stringent health and safety regulations for construction than OSHA.

## OFFICE OF SURFACE MINING RECLAMATION AND ENFORCEMENT (OSM)

OSM regulations are the most recent Federal blasting regulations, having been promulgated in 1979 (67).<sup>1</sup> These regulations, which deal only with surface coal mines and surface operations associated with underground coal mines, are environmental in nature. There are no Federal environmental regulations for metal-nonmetal mines. The OSM blasting regulations are designed to protect persons and property outside the mine area from potentially harmful effects of blasting. They deal with blaster qualifications, preblasting surveys, blasting schedules, control of ground vibrations and airblast, seismographic measurements, and blast records. The OSM regulations are found in CFR 30, in the following parts:

Chapter VII—OSM, Department of the Interior  
 Subchapter K—Permanent Program Performance Standards  
 Part 816—Surface Mining Activities  
 Sections 816.61—816.68, Use of Explosives  
 Part 817—Underground Mining Activities  
 Sections 817.61—817.68, Use of Explosives

In most cases, OSM regulations are enforced by the individual States. Some of these States may have more stringent environmental regulations than those of OSM.

## BUREAU OF ALCOHOL, TOBACCO AND FIREARMS (BATF)

BATF regulates security in the importation, manufacture, distribution, and storage of explosives. The primary goal of BATF is to prevent explosives from being used by unauthorized persons. Recordkeeping and secure storage are key requirements of the regulations. BATF has published updates of these regulations (65).

The BATF regulations are found in CFR 27, Part 181, Subparts A through J, as follows:

Subpart A—Introduction  
 Subpart B—Definitions  
 Subpart C—Administrative and Miscellaneous Proceedings  
 Subpart D—Licenses and Permits  
 Subpart E—License and Permit Proceedings  
 Subpart F—Conduct of Business or Operations  
 Subpart G—Records and Reports

<sup>1</sup> Italicized numbers in parentheses refer to items in the bibliography preceding the appendices.



Subpart H—Exemptions  
 Subpart I—Unlawful Acts, Penalties, Seizures, and Forfeitures  
 Subpart J—Storage

Subpart G, Records and Reports, and Subpart J, Storage, are enforced by MSHA under a memorandum of understanding with BATF. BATF enforces the remainder of the regulations.

## DEPARTMENT OF TRANSPORTATION (DOT)

DOT regulates the safe shipment of explosives in interstate commerce, including proper identification, packaging, public protection, and transportation vehicles. Many State and local agencies have adopted equal or more stringent regulations for transportation of explosives within their jurisdiction. The DOT regulations are found in CFR 49, Chapters I and III, as follows:

### Chapter I—Research and Special Programs Administration

#### Subchapter C—Hazardous Material Regulations

Part 171—General Information, Regulations, and Definitions

Part 172—Hazardous Materials Table and Hazardous Materials Communication Regulations

Part 173—Shipper General Requirements for Shipments and Packaging

Part 174—Carriage by Rail

Part 175—Carriage by Aircraft

Part 176—Carriage by Vessel

Part 177—Carriage by Public Highway  
 Chapter III—Federal Highway Administration  
 Subchapter B—Motor Carrier Safety Regulations  
 Part 397—Transportation of Hazardous Materials:  
 Driving and Parking Rules

No attempt has been made here to analyze or interpret the regulations cited in this appendix. It is important that every blaster has access to and reads these regulations to make sure that he or she is in compliance with them. Interpretation of regulations is often a difficult process. Where a blaster is not sure exactly how a regulation pertains to his or her operation, an interpretation should be obtained from a representative of the regulatory agency.

In addition to these specific blasting regulations, blasting operations are also governed by other regulations that apply across the board to all industries, such as air quality control and nuisance noise.

## APPENDIX B.—GLOSSARY OF TERMS USED IN EXPLOSIVES AND BLASTING<sup>1</sup>

**Acoustical impedance.**—The mathematical expression characterizing a material as to its energy transfer properties. The product of its unit density and its sonic velocity.

**Adobe charge.**—See mud cap.

**Airblast.**—An airborne shock wave resulting from the detonation of explosives. May be caused by burden movement or the release of expanding gas into the air. Airblast may or may not be audible.

**Airdox.**—A system that uses 10,000 psi compressed air to break undercut coal. Airdox will not ignite a gassy or dusty atmosphere.

**Aluminum.**—A metal commonly used as a fuel or sensitizing agent in explosives and blasting agents. Normally used in finely divided particle or flake form.

**American Table of Distances.**—A quantity-distance table published by IME as pamphlet No. 2, which specifies safe explosive storage distances from inhabited buildings, public highways, passenger railways and other stored explosive materials.

**Ammonium nitrate (AN).**—The most commonly used oxidizer in explosives and blasting agents. Its formula is  $\text{NH}_4\text{NO}_3$ .

**AN-FO.**—An explosive material consisting of ammonium nitrate and fuel oil. The most commonly used blasting agent.

**Axial priming.**—A system for priming blasting agents in which a core of priming material extends through most or all of the blasting agent charge length.

**Back break.**—Rock broken beyond the limits of the last row of holes.

**Back holes.**—The top holes in a tunnel or drift round.

**Base charge.**—The main explosive charge in a detonator.

**BATF.**—Bureau of Alcohol, Tobacco and Firearms, U.S. Department of the Treasury, which enforces explosives control and security regulations.

**Beds or bedding.**—Layers of sedimentary rock, usually separated by a surface of discontinuity. As a rule, the rock can be readily separated along these planes.

**Bench.**—The horizontal ledge in a quarry face along which holes are drilled vertically. Benching is the process of excavating whereby terraces or ledges are worked in a stepped sequence.

**Binary explosive.**—An explosive based on two nonexplosive ingredients, such as nitromethane and ammonium nitrate, which are shipped and stored separately and mixed at the jobsite to form a high explosive.

**Black powder.**—A low explosive consisting of sodium or potassium nitrate, carbon, and sulfur. Black powder is seldom used today because of its low energy, poor fume quality, and extreme sensitivity to sparks.

**Blast.**—The detonation of explosives to break rock.

**Blast area.**—The area near a blast within the influence of flying rock missiles, or concussion.

**Blaster.**—A qualified person in charge of a blast. Also, a person (blaster-in-charge) who has passed a test, approved by OSM, which certifies his or her qualifications to supervise blasting activities.

**Blasters' galvanometer; blasters' multimeter.**—See galvanometer; multimeter.

**Blasthole.**—A hole drilled in rock or other material for the placement of explosives.

**Blasting agent.**—An explosive that meets prescribed criteria for insensitivity to initiation. For storage, any material or mixture consisting of a fuel and oxidizer, intended for blasting, not otherwise defined as an explosive, provided that the finished product, as mixed and packaged for use or shipment, cannot be detonated by means of a No. 8 test blasting cap when unconfined (BATF). For transportation, a material designed for blasting which has been tested in accordance with CFR 49, Section 173.14a, and found to be so insensitive that there is very little probability of accidental initiation to explosion or transition from deflagration to detonation (DOT).

**Blasting cap.**—A detonator that is initiated by safety fuse (MSHA). See also detonator.

**Blasting circuit.**—The electrical circuit used to fire one or more electric blasting caps.

**Blasting crew.**—A group of persons whose purpose is to load explosive charges.

**Blasting machine.**—Any machine built expressly for the purpose of energizing electric blasting caps or other types of initiator.

**Blasting mat.**—See mat.

**Blasting switch.**—A switch used to connect a power source to a blasting circuit.

**Blistering.**—See mud cap.

**Blockhole.**—A hole drilled into a boulder to allow the placement of a small charge to break the boulder.

**Booster.**—A unit of explosive or blasting agent used for perpetuating or intensifying an explosive reaction. A booster does not contain an initiating device but is often cap sensitive.

**Bootleg.**—That portion of a borehole that remains relatively intact after having been charged with explosive and fired. A bootleg may contain unfired explosive and should be considered hazardous.

**Borehole (blasthole).**—A drilled hole, usually in rock, into which explosives are loaded for blasting.

**Borehole pressure.**—The pressure which the hot gases of detonation exert on the borehole wall. Borehole pressure is primarily a function of the density of the explosive and the heat of explosion.

**Bridge wire.**—A very fine filament wire imbedded in the ignition element of an electric blasting cap. An electric current passing through the wire causes a sudden heat rise, causing the ignition element to be ignited.

**Brisance.**—A property of an explosive roughly equivalent to detonation velocity. An explosive with a high detonation velocity has high brisance.

**Bubble energy.**—The expanding gas energy of an explosive, as measured in an underwater test.

**Bulk mix.**—A mass of explosive material prepared for use without packaging.

**Bulk strength.**—The strength of an explosive per unit volume.

**Bulldoze.**—See mud cap.

**Burden.**—The distance from an explosive charge to the nearest free or open face. Technically, there may be an apparent burden and a true burden, the latter being measured in the direction in which displacement of broken rock will occur following firing of the explosive charge. Also, the amount of material to be blasted by a given hole, given in tons or cubic yards.

<sup>1</sup> Additional definitions can be found in Institute of Makers of Explosives Pamphlet No. 12, Glossary of Industry Terms, September 1981, 28 pp.

**Burn cut.**—A parallel hole cut employing several closely spaced blastholes. Not all of the holes are loaded with explosive. The cut creates a cylindrical opening by shattering the rock.

**Bus wires.**—The two wires, joined to the connecting wire, to which the leg wires of the electric caps are connected in a parallel circuit. Each leg wire of each cap is connected to a different bus wire. In a series-in-parallel circuit, each end of each series is connected to a different bus wire.

**Butt.**—See bootleg.

**Cap.**—See detonator.

**Capped fuse.**—A length of safety fuse to which a blasting cap has been attached.

**Capped primer.**—A package or cartridge of cap-sensitive explosive which is specifically designed to transmit detonation to other explosives and which contains a detonator (MSHA).

**Cap sensitivity.**—The sensitivity of an explosive to initiation, expressed in terms of an IME No. 8 test detonator or a fraction thereof.

**Carbon monoxide.**—A poisonous gas created by detonating explosive materials. Excessive carbon monoxide is caused by an inadequate amount of oxygen in the explosive mixture (excessive fuel).

**Cardox.**—A system that uses a cartridge filled with liquid carbon dioxide, which, when initiated by a mixture of potassium perchlorate and charcoal, creates a pressure adequate to break undercut coal.

**Cartridge.**—A rigid or semirigid container of explosive or blasting agent of a specified length or diameter.

**Cartridge count.**—The number of 1¼- by 8-in cartridges of explosives per 50-lb case.

**Cartridge strength.**—A rating that compares a given volume of explosive with an equivalent volume of straight nitroglycerin dynamite, expressed as a percentage.

**Cast primer.**—A cast unit of explosive, usually pentolite or composition B, commonly used to initiate detonation in a blasting agent.

**Chambering.**—The process of enlarging a portion of blasthole (usually the bottom) by firing a series of small explosive charges. Chambering can also be done by mechanical or thermal methods.

**Chapman-Jouguet (C-J) plane.**—In a detonating explosive column, the plane that defines the rear boundary of the primary reaction zone.

**Circuit tester.**—See galvanometer; multimeter.

**Class A explosive.**—Defined by the U.S. Department of Transportation (DOT) as an explosive that possesses detonating or otherwise maximum hazard; such as, but not limited to, dynamite, nitroglycerin, lead azide, black powder, blasting caps, and detonating primers.

**Class B explosive.**—Defined by DOT as an explosive that possesses flammable hazard; such as, but not limited to, propellant explosives, photographic flash powders, and some special fireworks.

**Class C explosive.**—Defined by DOT as an explosive that contains Class A or Class B explosives, or both, as components but in restricted quantities. For example, blasting caps or electric blasting caps in lots of less than 1,000.

**Collar.**—The mouth or opening of a borehole or shaft. To collar in drilling means the act of starting a borehole.

**Collar distance.**—The distance from the top of the powder column to the collar of the blasthole, usually filled with stemming.

**Column charge.**—A long, continuous charge of explosive or blasting agent in a borehole.

**Commercial explosives.**—Explosives designed and used for commercial or industrial, rather than military applications.

**Composition B.**—A mixture of RDX and TNT which, when cast, has a density of 1.65 g/cu cm and a velocity of 25,000 fps. It is useful as a primer for blasting agents.

**Condenser-discharge blasting machine.**—A blasting machine that uses batteries or magnets to energize one or more condensers (capacitors) whose stored energy is released into a blasting circuit.

**Confined detonation velocity.**—The detonation velocity of an explosive or blasting agent under confinement, such as in a borehole.

**Connecting wire.**—A wire, smaller in gage than the lead wire, used in a blasting circuit to connect the cap circuit with the lead wire or to extend leg wires from one borehole to another. Usually considered expendable.

**Connector.**—See MS connector.

**Controlled blasting.**—Techniques used to control overbreak and produce a competent final excavation wall. See line drilling, preplitting, smooth blasting, and cushion blasting.

**Cordeau detonant fuse.**—A term used to define detonating cord.

**Cornish cut.**—See parallel hole cut.

**Coromant cut.**—See parallel hole cut.

**Coupling.**—The degree to which an explosive fills the borehole. Bulk loaded explosives are completely coupled. Untamped cartridges are decoupled. Also, capacitive and inductive coupling from powerlines, which may be introduced into an electric blasting circuit.

**Coyote blasting.**—The practice of driving tunnels horizontally into a rock face at the foot of the shot. Explosives are loaded into these tunnels. Coyote blasting is used where it is impractical to drill vertically.

**Critical diameter.**—For any explosive, the minimum diameter for propagation of a stable detonation. Critical diameter is affected by confinement, temperature, and pressure on the explosive.

**Crosslinking agent.**—The final ingredient added to a water gel or slurry, causing it to change from a liquid to a gel.

**Current limiting device.**—A device used to prevent arcing in electric blasting caps by limiting the amount or duration of current flow. Also used in a blasters' galvanometer or multimeter to assure a safe current output.

**Cushion blasting.**—A surface blasting technique used to produce competent slopes. The cushion holes, fired after the main charge, have a reduced spacing and employ decoupled charges.

**Cushion stick.**—A cartridge of explosive loaded into a small-diameter borehole before the primer. The use of a cushion stick is not generally recommended because of possible resulting bootlegs.

**Cut.**—An arrangement of holes used in underground mining and tunnel blasting to provide a free face to which the remainder of the round can break. Also the opening created by the cut holes.

**Cutoffs.**—A portion of a column of explosives that has failed to detonate owing to bridging or a shifting of the rock formation, often due to an improper delay system. Also a cessation of detonation in detonating cord.

**Dead pressing.**—Desensitization of an explosive, caused by pressurization. Tiny air bubbles, required for sensitivity, are literally squeezed from the mixture.

**Decibel.**—The unit of sound pressure commonly used to

measure airblast from explosives. The decibel scale is logarithmic.

**Deck.**—A small charge or portion of a blasthole loaded with explosives which is separated from other charges by stemming or an air cushion.

**Decoupling.**—The use of cartridged products significantly smaller in diameter than the borehole. Decoupled charges are normally not used except in cushion blasting, smooth blasting, presplitting, and other situations where crushing is undesirable.

**Deflagration.**—A subsonic but extremely rapid explosive reaction accompanied by gas formation and borehole pressure, but without shock.

**Delay blasting.**—The use of delay detonators or connectors that cause separate charges to detonate at different times, rather than simultaneously.

**Delay connector.**—A nonelectric, short-interval delay device for use in delaying blasts that are initiated by detonating cord.

**Delay detonator.**—A detonator, either electric or nonelectric, with a built-in element that creates a delay between the input of energy and the explosion of the detonator.

**Delay electric blasting cap.**—An electric blasting cap with a built-in delay that delays cap detonation in predetermined time intervals, from milliseconds up to a second or more, between successive delays.

**Delay element.**—That portion of a blasting cap which causes a delay between the instant of application of energy to the cap and the time of detonation of the base charge of the cap.

**Density.**—The weight per unit volume of explosive, expressed as cartridge count or grams per cubic centimeter. See loading density.

**Department of Transportation (DOT).**—A Federal agency that regulates safety in interstate shipping of explosives and other hazardous materials.

**Detaline System.**—A nonelectric system for initiating blasting caps in which the energy is transmitted through the circuit by means of a low-energy detonating cord.

**Detonating cord.**—A plastic-covered core of high-velocity explosive, usually PETN, used to detonate charges of explosives. The plastic covering, in turn, is covered with various combinations of textiles and waterproofing.

**Detonation.**—A supersonic explosive reaction that propagates a shock wave through the explosive accompanied by a chemical reaction that furnishes energy to sustain the shock wave propagation in a stable manner. Detonation creates both a detonation pressure and a borehole pressure.

**Detonation pressure.**—The head-on pressure created by the detonation proceeding down the explosive column. Detonation pressure is a function of the explosive's density and the square of its velocity.

**Detonation velocity.**—See velocity.

**Detonator.**—Any device containing a detonating charge that is used to initiate an explosive. Includes, but is not limited to, blasting caps, electric blasting caps, and nonelectric instantaneous or delay blasting caps.

**Ditch blasting.**—See propagation blasting.

**DOT.**—See Department of Transportation.

**Downline.**—The line of detonating cord in the borehole which transmits energy from the trunkline down the hole to the primer.

**Drilling pattern.**—See pattern.

**Drop ball.**—Known also as a headache ball. An iron or steel weight held on a wire rope which is dropped from a height onto large boulders for the purpose of breaking them into smaller fragments.

**Dynamite.**—The high explosive invented by Alfred Nobel.

Any high explosive in which the sensitizer is nitroglycerin or a similar explosive oil.

**Echelon pattern.**—A delay pattern that causes the true burden, at the time of detonation, to be at an oblique angle from the original free face.

**Electric blasting cap.**—A blasting cap designed to be initiated by an electric current.

**Electric storm.**—An atmospheric disturbance of intense electrical activity presenting a hazard in all blasting activities.

**Emulsion.**—An explosive material containing substantial amounts of oxidizers dissolved in water droplets surrounded by an immiscible fuel. Similar to a slurry in some respects.

**Exploding bridge wire (EBW).**—A wire that explodes upon application of current. It takes the place of the primary explosive in an electric detonator. An exploding bridge wire detonator is an electric detonator that employs an exploding bridge wire rather than a primary explosive. An exploding bridge wire detonator functions instantaneously.

**Explosion.**—A thermochemical process in which mixtures of gases, solids, or liquids react with the almost instantaneous formation of gaseous pressures and sudden heat release.

**Explosion pressure.**—See borehole pressure.

**Explosive.**—Any chemical mixture that reacts at high velocity to liberate gas and heat, causing very high pressures. BATF classifications include high explosives and low explosives. Also, any substance classified as an explosive by DOT.

**Explosive materials.**—A term which includes, but is not necessarily limited to, dynamite and other high explosives, slurries, water gels, emulsions, blasting agents, black powder, pellet powder, initiating explosives, detonators, safety fuses, squibs, detonating cord, igniter cord, and igniters.

**Extra dynamite.**—Also called ammonia dynamite, a dynamite that derives the major portion of its energy from ammonium nitrate.

**Extraneous electricity.**—Electrical energy, other than actual firing current, which may be a hazard with electric blasting caps. Includes stray current, static electricity, lightning, radio-frequency energy, and capacitive or inductive coupling.

**Face.**—A rock surface exposed to air. Also called a free face, a face provides the rock with room to expand upon fragmentation.

**Firing current.**—Electric current purposely introduced into a blasting circuit for the purpose of initiation. Also, the amount of current required to activate an electric blasting cap.

**Firing line.**—A line, often permanent, extending from the firing location to the electric blasting cap circuit. Also called lead wire.

**Flash over.**—Sympathetic detonation between explosive charges or between charged blastholes.

**Flyrock.**—Rock that is propelled through the air from a blast. Excessive flyrock may be caused by poor blast design or unexpected zones of weakness in the rock.

**Fracturing.**—The breaking of rock with or without movement of the broken pieces.

**Fragmentation.**—The extent to which a rock is broken into pieces by blasting. Also the act of breaking rock.

**Fuel.**—An ingredient in an explosive which reacts with an oxidizer to form gaseous products of detonation.

**Fuel oil.**—The fuel, usually No. 2 diesel fuel, in AN-FO.

**Fume classification.**—An IME quantification of the amount of fumes generated by an explosive or blasting agent.

**Fume quality.**—A measure of the toxic fumes to be expected when a specific explosive is properly detonated. See fumes.

**Fumes.**—Noxious or poisonous gases liberated from a blast. May be due to a low fume quality explosive or inefficient detonation.

**Fuse.**—See safety fuse.

**Fuse lighter.**—A pyrotechnic device for rapid and dependable lighting of safety fuse.

**Galvanometer.**—(More properly called blasters' galvanometer.) A measuring instrument containing a silver chloride cell and/or a current limiting device which is used to measure resistance in an electric blasting circuit. Only a device specifically identified as a blasting galvanometer or blasting multimeter should be used for this purpose.

**Gap sensitivity.**—A measure of the distance across which an explosive can propagate a detonation. The gap may be air or a defined solid material. Gap sensitivity is a measure of the likelihood of sympathetic propagation.

**Gas detonation system.**—A system for initiating caps in which the energy is transmitted through the circuit by means of a gas detonation inside a hollow plastic tube.

**Gelatin.**—An explosive or blasting agent that has a gelatinous consistency. The term is usually applied to a gelatin dynamite but may also be a water gel.

**Gelatin dynamite.**—A highly water-resistant dynamite with a gelatinous consistency.

**Generator blasting machine.**—A blasting machine operated by vigorously pushing down a rack bar or twisting a handle. Now largely replaced by condenser discharge blasting machines.

**Grains.**—A system of weight measurement in which 7,000 grains equal 1 lb.

**Ground vibration.**—A shaking of the ground caused by the elastic wave emanating from a blast. Excessive vibrations may cause damage to structures.

**Hangfire.**—The detonation of an explosive charge at a time after its designed firing time. A source of serious accidents.

**Heading.**—A horizontal excavation driven in an underground mine.

**Hercudet.**—See gas detonation system.

**Hertz.**—A term used to express the frequency of ground vibrations and airblast. One hertz is one cycle per second.

**High explosive.**—Any product used in blasting which is sensitive to a No. 8 test blasting cap and reacts at a speed faster than that of sound in the explosive medium. A classification used by BATF for explosive storage.

**Highwall.**—The bench, bluff, or ledge on the edge of a surface excavation. This term is most commonly used in coal strip mining.

**Ignitacord.**—A cordlike fuse that burns progressively along its length with an external flame at the zone of burning and is used for lighting a series of safety fuses in sequence. Burns with a spitting flame similar to a Fourth-of-July sparkler.

**IME.**—The Institute of Makers of Explosives. A trade organization dealing with the use of explosives, concerned with safety in manufacture, transportation, storage, handling, and use. The IME publishes a series of blasting safety pamphlets.

**Initiation.**—The act of detonating a high explosive by means of a cap, a mechanical device, or other means. Also the act of detonating the initiator.

**Instantaneous detonator.**—A detonator that contains no delay element.

**Jet loader.**—A system for loading AN-FO into small blastholes in which the AN-FO is drawn from a container by the venturi principle and blown into the hole at high velocity through a semiconductive loading hose.

**Joints.**—Planes within a rock mass along which there is no resistance to separation and along which there has been no relative movement of the material on either side. Joints occur in sets, the planes of which may be mutually perpendicular. Joints are often called partings.

**Jumbo.**—A machine designed to contain two or more mounted drilling units that may or may not be operated independently.

**Kerf.**—A slot cut in a coal or soft rock face by a mechanical cutter to provide a free face for blasting.

**Lead wire.**—The wire connecting the electrical power source with the leg wires or connecting wires of a blasting circuit. Also called firing line.

**LEDC.**—Low energy detonating cord, which may be used to initiate nonelectric blasting caps.

**Leg wires.**—Wires connected to the bridge wire of an electric blasting cap and extending from the waterproof plug. The opposite ends are used to connect the cap into a circuit.

**Lifters.**—The bottom holes in a tunnel or drift round.

**Line drilling.**—A method of overbreak control in which a series of very closely spaced holes are drilled at the perimeter of the excavation. These holes are not loaded with explosive.

**Liquid oxygen explosive.**—A high explosive made by soaking cartridges of carbonaceous materials in liquid oxygen. This explosive is rarely used today.

**Loading density.**—An expression of explosive density in terms of pounds of explosive per foot of charge of a specific diameter.

**Loading factor.**—See powder factor.

**Loading pole.**—A pole made of nonsparking material, used to push explosive cartridges into a borehole and to break and tightly pack the explosive cartridges into the hole.

**Low explosive.**—An explosive in which the speed of reaction is slower than the speed of sound, such as black powder. A classification used by BATF for explosive storage.

**LOX.**—See liquid oxygen explosive.

**Magazine.**—A building, structure, or container specially constructed for storing explosives, blasting agents, detonators, or other explosive materials.

**Mat.**—A covering placed over a shot to hold down flying material; usually made of woven wire cable, rope, or scrap tires.

**Maximum firing current.**—The highest current (amperage) recommended for the safe and effective performance of an electric blasting cap.

**Metallized.**—Sensitized or energized with finely divided metal flakes, powders, or granules, usually aluminum.

**Michigan cut.**—See parallel hole cut.

**Microballoons.**—Tiny hollow spheres of glass or plastic which are added to explosive materials to enhance sensitivity by assuring an adequate content of entrapped air.

**Millisecond.**—The unit of measurement of short delay intervals, equal to 1/1000 of a second.

**Millisecond delay caps.**—Delay detonators that have built-in time delays of various lengths. The interval between the delays at the lower end of the series is usually 25 ms. The interval between delays at the upper end of the series may be 100 to 300 ms.

**Minimum firing current.**—The lowest current (amperage) that will initiate an electric blasting cap within a specified short interval of time.

**Misfire.**—A charge, or part of a charge, which for any reason has failed to fire as planned. All misfires are dangerous.

**Monomethylammonium nitrate.**—A compound used to sensitize some water gels.

**MS connector.**—A device used as a delay in a detonating cord circuit connecting one hole in the circuit with another or one row of holes to other rows of holes.

**MSHA.**—The Mine Safety and Health Administration. An agency under the Department of Labor which enforces health and safety regulations in the mining industry.

**Muckpile.**—A pile of broken rock or dirt that is to be loaded for removal.

**Mud cap.**—Referred to also as adobe, bulldoze, blistering, or plaster shot. A charge of explosive fired in contact with the surface of a rock, usually covered with a quantity of mud, wet earth, or similar substance. No borehole is used.

**Multimeter.**—(More properly called blasters' multimeter.) A multipurpose test instrument used to check line voltages, firing circuits, current leakage, stray currents, and other measurements pertinent to electric blasting. Only a meter specifically designated as a blasters' multimeter or blasters' galvanometer should be used to test electric blasting circuits.

**National Fire Protection Association (NFPA).**—An industry-government association that publishes standards for explosive material and ammonium nitrate.

**Nitrocarbonitrate.**—A classification once given to a blasting agent by DOT for shipping purposes. This term is now obsolete.

**Nitrogen oxides.**—Poisonous gases created by detonating explosive materials. Excessive nitrogen oxides may be caused by an excessive amount of oxygen in the explosive mixture (excessive oxidizer), or by inefficient detonation.

**Nitroglycerin (NG).**—The explosive oil originally used as the sensitizer in dynamites, represented by the formula  $C_3H_5(ONO_2)_3$ .

**Nitromethane.**—A liquid compound used as a fuel in two-component (binary) explosives and as rocket fuel.

**Nitropropane.**—A liquid fuel that can be combined with pulverized ammonium nitrate prills to make a dense blasting mixture.

**Nitrostarch.**—A solid explosive, similar to nitroglycerin in function, used as the base of "nonheadache" powders.

**Nonel.**—See shock tube system.

**Nonelectric delay blasting cap.**—A detonator with a delay element, capable of being initiated nonelectrically. See shock tube system; gas detonation system; Detaline System.

**No. 8 test blasting cap.**—See test blasting cap No. 8.

**OSHA.**—The Occupational Safety and Health Administration. An agency under the Department of Labor which enforces health and safety regulations in the construction industry, including blasting.

**OSM.**—The Office of Surface Mining Reclamation and Enforcement. An agency under the Department of Interior which enforces surface environmental regulations in the coal mining industry.

**Overbreak.**—Excessive breakage of rock beyond the desired excavation limit.

**Overburden.**—Worthless material lying on top of a deposit of useful materials. Overburden often refers to dirt or gravel, but can be rock, such as shale over limestone or shale and limestone over coal.

**Overdrive.**—The act of inducing a velocity higher than the steady state velocity in a powder column by the use of a powerful primer. Overdrive is a temporary phenomenon and the powder quickly assumes its steady state velocity.

**Oxides of nitrogen.**—See nitrogen oxides.

**Oxidizer.**—An ingredient in an explosive or blasting agent which supplies oxygen to combine with the fuel to form gaseous or solid products of detonation. Ammonium nitrate is the most common oxidizer used in commercial explosives.

**Oxygen balance.**—A state of equilibrium in a mixture of fuels and oxidizers at which the gaseous products of detonation are predominately carbon dioxide, water vapor (steam), and free nitrogen. A mixture containing excess oxygen has a positive oxygen balance. One with excess fuel has a negative oxygen balance.

**Parallel circuit.**—A circuit in which two wires, called bus wires, extend from the lead wire. One leg wire from each cap in the circuit is hooked to each of the bus wires.

**Parallel hole cut.**—A group of parallel holes, some of which are loaded with explosives, used to establish a free face in tunnel or heading blasting. One or more of the unloaded holes may be larger than the blastholes. Also called Coromant, Cornish, burn, shatter, or Michigan cut.

**Parallel series circuit.**—Similar to a parallel circuit, but involving two or more series of electric blasting caps. One end of each series of caps is connected to each of the bus wires. Sometimes called series-in-parallel circuit.

**Particle velocity.**—A measure of ground vibration. Describes the velocity at which a particle of ground vibrates when excited by a seismic wave.

**Pattern.**—A plan of holes laid out on a face or bench which are to be drilled for blasting. Burden and spacing dimensions are usually expressed in feet.

**Pellet powder.**—Black powder pressed into 2-in-long, 1¼-in to 2-in diameter cylindrical pellets.

**Pentaerythritoltetranitrate (PETN).**—A military explosive compound used as the core load of detonating cord and the base charge of blasting caps.

**Pentolite.**—A mixture of PETN and TNT which, when cast, is used as a cast primer.

**Permissible.**—A machine, material, apparatus, or device that has been investigated, tested, and approved by the Bureau of Mines or MSHA, and is maintained in permissible condition (MSHA).

**Permissible blasting.**—Blasting according to MSHA regulations for underground coal mines or other gassy underground mines.

**Permissible explosives.**—Explosives that have been approved by MSHA for use in underground coal mines or other gassy mines.

**PETN.**—See pentaerythritoltetranitrate.

**Placards.**—Signs placed on vehicles transporting hazardous materials, including explosives, indicating the nature of the cargo.

**Plaster shot.**—See mud cap.

**Pneumatic loader.**—One of a variety of machines, powered by compressed air, used to load bulk blasting agents or cartridge water gels.

**Powder.**—Any solid explosive.

**Powder chest.**—A substantial, nonconductive portable container equipped with a lid and used at blasting sites for temporary storage of explosives.

**Powder factor.**—A ratio between the amount of powder loaded and the amount of rock broken, usually expressed as pounds per ton or pounds per cubic yard. In some cases, the reciprocals of these terms are used.

**Presplitting.**—A form of controlled blasting in which decoupled charges are fired in closely spaced holes at the perimeter of the excavation. A presplit blast is fired before the main blast. Also called preshearing.

**Premature.**—A charge that detonates before it is intended. Prematures can be hazardous.

**Preshearing.**—See presplitting.

**Presplitting.**—A form of controlled blasting in which decoupled charges are fired in closely spaced holes at the perimeter of the excavation. A presplit blast is fired before the main blast. Also called preshearing.

**Pressure vessel.**—A system for loading AN-FO into small-diameter blastholes. The AN-FO is contained in a sealed vessel, to which air pressure is applied, forcing the AN-FO through a semiconductive hose and into the blasthole. Also known as pressure pot.

**Prill.**—In blasting, a small porous sphere of ammonium nitrate capable of absorbing more than 6 pct by weight of fuel oil. Blasting prills have a bulk density of 0.80 to 0.85 g/cu cm.

**Primary blast.**—The main blast executed to sustain production.

**Primary explosive.**—An explosive or explosive mixture, sensitive to spark, flame, impact or friction, used in a detonator to initiate the explosion.

**Primer.**—A unit, package, or cartridge of cap-sensitive explosive used to initiate other explosives or blasting agents and which contains a detonator (MSHA).

**Propagation.**—The detonation of explosive charges by an impulse from a nearby explosive charge.

**Propagation blasting.**—The use of closely spaced, sensitive charges. The shock from the first charge propagates through the ground, setting off the adjacent charge, and so on. Only one detonator is required. Primarily used for ditching in damp ground.

**Propellant explosive.**—An explosive that normally deflagrates and is used for propulsion.

**Pull.**—The quantity of rock or length of advance excavated by a blast round.

**Radiofrequency energy.**—Electrical energy traveling through the air as radio or electromagnetic waves. Under ideal conditions, this energy can fire an electric blasting cap. IME Pamphlet No. 20 recommends safe distances from transmitters to electric blasting caps.

**Radiofrequency transmitter.**—An electric device, such as a stationary or mobile radio transmitting station, which transmits a radiofrequency wave.

**RDX.**—Cyclotrimethylenetrinitramine, an explosive substance used in the manufacture of compositions B, C-3, and C-4. Composition B is useful as a cast primer.

**Relievers.**—In a heading round, holes adjacent to the cut holes, used to expand the opening made by the cut holes.

**Rib holes.**—The holes at the sides of a tunnel or drift round, which determine the width of the opening.

**Rip rap.**—Coarse rocks used for river bank or dam stabilization to reduce erosion by water flow.

**Rotational firing.**—A delay blasting system in which each charge successively displaces its burden into a void created by an explosive detonated on an earlier delay period.

**Round.**—A group or set of blastholes required to produce a unit of advance in underground headings or tunnels.

**Safety fuse.**—A core of potassium nitrate black powder, enclosed in a covering of textile and waterproofing, which is used to initiate a blasting cap or a black powder charge. Safety fuse burns at a continuous, uniform rate.

**Scaled distance.**—A ratio used to predict ground vibrations. As commonly used in blasting, scaled distance equals the distance from the blast to the point of concern, in feet, divided by the square root of the charge weight of explosive per delay, in pounds. Normally, when using the equation, the delay period must be at least 9 ms.

**Secondary blasting.**—Using explosives to break boulders or high bottom resulting from the primary blast.

**Seismograph.**—An instrument that measures and may supply a permanent record of earthborne vibrations induced by earthquakes or blasting.

**Semiconductive hose.**—A hose, used for pneumatic loading of AN-FO, which has a minimum electrical resistance of 1,000 ohms/ft and 10,000 ohms total resistance and a maximum total resistance of 2,000,000 ohms.

**Sensitiveness.**—A measure of an explosive's ability to propagate a detonation.

**Sensitivity.**—A measure of an explosive's susceptibility to detonation upon receiving an external impulse such as impact, shock, flame, or friction.

**Sensitizer.**—An ingredient used in explosive compounds to promote greater ease in initiation or propagation of the detonation reaction.

**Sequential blasting machine.**—A series of condenser discharge blasting machines in a single unit which can be activated at various accurately timed intervals following the application of electrical current.

**Series circuit.**—A circuit of electric blasting caps in which each leg wire of a cap is connected to a leg wire from the adjacent caps so that the electrical current follows a single path through the entire circuit.

**Series-in-parallel circuit.**—See parallel series circuit.

**Shatter cut.**—See parallel hole cut.

**Shelf life.**—The length of time for which an explosive can be stored without losing its efficient performance characteristics.

**Shock energy.**—The shattering force of an explosive caused by the detonation wave.

**Shock tube system.**—A system for initiating caps in which the energy is transmitted to the cap by means of a shock wave inside a hollow plastic tube.

**Shock wave.**—A pressure pulse that propagates at supersonic velocity.

**Shot.**—See blast.

**Shot firer.**—Also referred to as the shooter. The person who actually fires a blast. A powderman, on the other hand, may charge or load blastholes with explosives but may not fire the blast.

**Shunt.**—A piece of metal or metal foil which short circuits the ends of cap leg wires to prevent stray currents from causing accidental detonation of the cap.

**Silver chloride cell.**—A low-current cell used in a blasting galvanometer and other devices used to measure continuity in electric blasting caps and circuits.

**Slurry.**—An aqueous solution of ammonium nitrate, sensitized with a fuel, thickened, and crosslinked to provide a gelatinous consistency. Sometimes called a water gel. DOT may classify a slurry as a Class A explosive, a Class B explosive, or a blasting agent. An explosive or blasting agent containing

substantial portions of water (MSHA). See emulsion; water gel.

**Smooth blasting.**—A method of controlled blasting, used underground, in which a series of closely spaced holes is drilled at the perimeter, loaded with decoupled charges, and fired on the highest delay period of the blast round.

**Snake hole.**—A borehole drilled slightly downward from horizontal into the floor of a quarry face. Also, a hole drilled under a boulder.

**Sodium nitrate.**—An oxidizer used in dynamites and sometimes in blasting agents.

**Spacing.**—The distance between boreholes or charges in a row, measured perpendicular to the burden and parallel to the free face of expected rock movement.

**Specific gravity.**—The ratio of the weight of a given volume of any substance to the weight of an equal volume of water.

**Spitter cord.**—See Ignitacord.

**Springing.**—See chambering.

**Square pattern.**—A pattern of blastholes in which the holes in succeeding rows are drilled directly behind the holes in the front row. In a truly square pattern the burden and spacing are equal.

**Squib.**—A firing device that burns with a flash. Used to ignite black powder or pellet powder.

**Stability.**—The ability of an explosive material to maintain its physical and chemical properties over a period of time in storage.

**Staggered pattern.**—A pattern of blastholes in which holes in each row are drilled between the holes in the preceding row.

**Static electricity.**—Electrical energy stored on a person or object in a manner similar to that of a capacitor. Static electricity may be discharged into electrical initiators, thereby detonating them.

**Steady state velocity.**—The characteristic velocity at which a specific explosive, under specific conditions, in a given charge diameter, will detonate.

**Stemming.**—The inert material, such as drill cuttings, used in the collar portion (or elsewhere) of a blasthole to confine the gaseous products of detonation. Also, the length of blasthole left uncharged.

**Stick count.**—See cartridge count.

**Stray current.**—Current flowing outside its normal conductor. A result of defective insulation, it may come from electrical equipment, electrified fences, electric railways, or similar items. Flow is facilitated by conductive paths such as pipelines and wet ground or other wet materials. Galvanic action of two dissimilar metals, in contact or connected by a conductor, may cause stray current.

**Strength.**—A property of an explosive described in various terms such as cartridge or weight strength, seismic strength, shock or bubble energy, crater strength, ballistic mortar strength, etc. Not a well-defined property. Used to express an explosive's capacity to do work.

**String loading.**—The procedure of loading cartridges end to end in a borehole without deforming them. Used mainly in controlled blasting and permissible blasting.

**Subdrill.**—To drill blastholes beyond the planned grade lines or below floor level to insure breakage to the planned grade or floor level.

**Subsonic.**—Slower than the speed of sound.

**Supersonic.**—Faster than the speed of sound.

**Swell factor.**—The ratio of the volume of a material in its solid state to that when broken. May also be expressed as the reciprocal of this number.

**Sympathetic propagation (sympathetic detonation).**—Detonation of an explosive material by means of an impulse from another detonation through air, earth, or water.

**Tamping.**—The process of compressing the stemming or explosive in a blasthole. Sometimes used synonymously with stemming.

**Tamping bag.**—A cylindrical bag containing stemming material, used to confine explosive charges in boreholes.

**Tamping pole.**—See loading pole.

**Test blasting cap No. 8.**—A detonator containing 0.40 to 0.45 g of PETN base charge at a specific gravity of 1.4 g/cu cm, and primed with standard weights of primer, depending on the manufacturer.

**Toe.**—The burden or distance between the bottom of a borehole and the vertical free face of a bench in an excavation. Also the rock left unbroken at the foot of a quarry blast.

**Transient velocity.**—A velocity, different from the steady state velocity, which a primer imparts to a column of powder. The powder column quickly attains steady state velocity.

**Trinitrotoluene (TNT).**—A military explosive compound used industrially as a sensitizer for slurries and as an ingredient in pentolite and composition B. Once used as a free-running pelletized powder.

**Trunkline.**—A detonating cord line used to connect the downlines or other detonating cord lines in a blast pattern. Usually runs along each row of blastholes.

**Tunnel.**—A horizontal underground passage.

**Two-component explosive.**—See binary explosive.

**Unconfined detonation velocity.**—The detonation velocity of an explosive material not confined by a borehole or other confining medium.

**V-cut.**—A cut employing several pairs of angled holes, meeting at the bottoms, used to create free faces for the rest of the blast round.

**Velocity.**—The rate at which the detonation wave travels through an explosive. May be measured confined or unconfined. Manufacturer's data are sometimes measured with explosives confined in a steel pipe.

**Venturi loader.**—See jet loader.

**Volume strength.**—See cartridge strength or bulk strength.

**Water gel.**—Aqueous solution of ammonium nitrate, sensitized with a fuel, thickened, and crosslinked to provide a gelatinous consistency. Also called a slurry. May be an explosive or a blasting agent.

**Water resistance.**—A qualitative measure of the ability of an explosive or blasting agent to withstand exposure to water without becoming deteriorated or desensitized.

**Water stemming bags.**—Plastic bags containing a self-sealing device, which are filled with water. Classified as a permissible stemming device by MSHA.

**Weight strength.**—A rating that compares the strength of a given weight of explosive with an equivalent weight of straight nitroglycerin dynamite, or other explosive standard, expressed as a percentage.



