



PDHonline Course C824 (2 PDH)

An Introduction to Manual Layout of Arch Dams

Instructor: J. Paul Guyer, P.E., R.A., Fellow ASCE, Fellow AEI

2020

PDH Online | PDH Center

5272 Meadow Estates Drive
Fairfax, VA 22030-6658
Phone: 703-988-0088
www.PDHonline.com

An Approved Continuing Education Provider

An Introduction to Manual Layout of Arch Dams

J. Paul Guyer, P.E., R.A.

1. GENERAL DESIGN PROCESS. Design of an arch dam involves the layout of a tentative shape for the structure, preliminary static stress analysis of this layout, evaluation of the stress results, and refinement of the arch dam shape. Several iterations through the design process are necessary to produce a satisfactory design which exhibits stress levels within an acceptable range. The final dam layout that evolves from the iterative design process is then statically analyzed by the finite element method. "Static analysis" refers to the analysis performed after a layout has been achieved through the design process. "Preliminary stress analysis" refers to the method of analysis performed during the iterative design process to investigate the state of stress for tentative layouts. The computer program ADSAS (Arch Dam Stress Analysis System) (USBR 1975) is used for the preliminary stress analysis and is discussed in more detail in paragraph 5-5. GDAP (Graphics-based Dam Analysis Program) (Ghanaat 1993a) is a special purpose finite element program, specifically developed for the analysis of arch dams. GDAP is discussed in more detail in Chapter 6. Preliminary stress analyses are relatively quick and inexpensive to run compared to the static analysis which is more detailed, both in its input as well as its output. Although past history has shown that results from both procedures are comparable, an arch dam layout that reaches the static analysis phase may still require refinement, pending evaluation of static analysis results.

2. LEVELS OF DESIGN. There are three phases of the life cycle process of a project for which layouts are developed; reconnaissance, feasibility, and preconstruction engineering and design (PED). The degree of refinement for a layout is determined by the phase for which the design is developed.

2.1 RECONNAISSANCE PHASE. Of the three phases mentioned, the least amount of engineering design effort will be expended in the reconnaissance phase. Examination of existing topographic maps in conjunction with site visits should result in the selection of several potential sites. When selecting sites during the reconnaissance phase, emphasis should be placed on site suitability, i.e., sites with adequate canyon profiles and foundation characteristics.

2.1.1 RECONNAISSANCE LEVEL LAYOUTS FOR DIFFERENT sites can be produced quickly from the empirical equations discussed. Empirical equations to determine concrete quantities from these layouts are presented. Alternatively, the structural engineer may elect to base reconnaissance level layouts on previous designs which are similar in height, shape of profile, loading configuration, and for which stresses are satisfactory. However, it should be pointed out that most arch dams which have been constructed to date are single-center. Because the technology exists today which simplifies the layout of more efficient, multicentered arch dams, most dams that will be designed in the future will be of the multicentered variety. Therefore, basing a tentative, reconnaissance level layout on an existing single-center arch dam may result in conservative estimates of concrete quantity.

2.1.2 TOPOGRAPHIC MAPS OR QUAD SHEETS that cover an adequate reach of river provide sufficient engineering data for this phase. From this region, one or more potential sites are selected. The areas around these sites are enlarged to 1:50 or 1:100 scale drawings. These enlarged topographic sheets and the empirical formulas will produce the geometry and concrete volume for a reconnaissance level layout.

2.2 FEASIBILITY PHASE. Designs during the feasibility phase are used in the selection of the final site location and as a basis for establishing the baseline cost estimate. Feasibility designs are made in greater detail than reconnaissance designs since a closer approximation to final design is required.

2.2.1 AS A RESULT OF THE WORK PERFORMED during the reconnaissance phase, the structural engineer should now have available one or more potential sites to evaluate during the feasibility phase. Using the iterative layout process discussed, tentative designs will be plotted, analyzed, evaluated, and refined for each potential site until a proposed layout evolves that provides the best balance between minimal concrete volume and minimum stress level. From the sites evaluated and their respective layouts, the structural engineer will select the most economical design, and this will be carried into the PED phase. A baseline cost estimate will be developed for the final layout.

2.2.2 THE ITERATIVE LAYOUT PROCESS requires a certain amount of topographic and subsurface information. However, these data should be obtained with the knowledge that funds for feasibility studies are limited. Aerial topographic surveys of potential sites are required as well as a few core borings to determine an approximation of the depth of overburden. Loading conditions, as discussed, should be defined.

2.3 PRECONSTRUCTION ENGINEERING AND DESIGN. Design work during this phase is presented in the FDM which is also used to develop contract plans and specifications. The final design layout produced during the feasibility stage is subjected to further static and dynamic analysis during the PED phase. Any remaining load cases that have not been analyzed during the feasibility phase should be analyzed and evaluated at this time. This may require that any missing data (operating conditions, thermal loads, etc.) be finalized prior to the analysis. If results from all of the preliminary stress analysis load cases indicate the final layout is acceptable,

design may proceed to the static FEM analysis. Otherwise, the layout requires refinement.

3. PROCEDURE. A single-center, variable-thickness, arch dam is assumed for the purpose of discussion. The procedure for laying out other types of arch dams differs only in the way the arches are defined.

4. MANUAL LAYOUT. Although the term "Layout of an arch dam" implies a single procedure, layout actually consists of an iterative, refining process involving several layouts, each successive one improving on the previous. The first of these layouts require the structural designer to assume some initial parameters which will define the shape of the arch dam. As stated, a 1:50- or 1:100-scale topographic map of a dam site is required before layout begins. If possible, the contours should represent topography of foundation rock; however, in most instances, only surface topography is available at this stage of design. The structural designer must then assume a reasonable amount of overburden, based on core borings or sound judgement, to produce a topo sheet that reflects the excavated foundation.

4.1 AXIS. The crest elevation required for the dam should be known at this time from hydrologic data and this, in conjunction with the elevation of the streambed (or assumed foundation elevation) at the general location of the dam, determines the dam height, H (feet). The structural designer should select a value for the radius of the dam axis (RAXIS). For the initial layout where the engineer would have no reasonable estimate for the value of RAXIS from a previous layout, the following empirical relationship has been derived by the USBR based on historical data from existing dams:

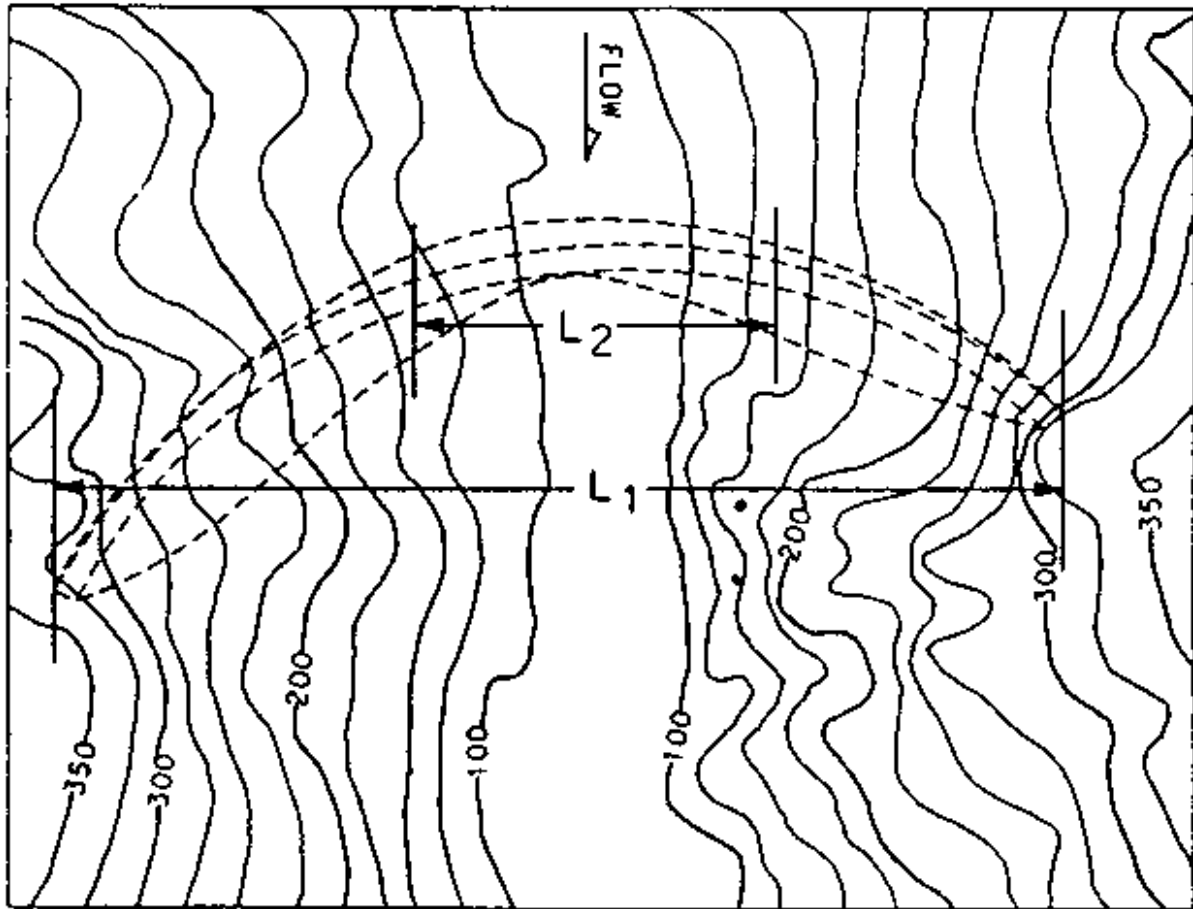

1 All elevations (el) cited herein are in feet referred to the National Geodetic Vertical Datum (NGVD).

Figure 5-1

Determination of empirical values L_1 and L_2

4.1.1 ON A SHEET OF VELLUM or transparent paper, an arc is drawn with a radius equal to RAXIS at the same scale as the topo sheet. This arc represents the axis of the dam. The vellum is then overlaid and positioned on the topo sheet so as to produce an optimum position and location for the dam crest; for this position, the angle of incidence to the topo contour at the crest elevation (b in Figure 2-1) should be approximately equal on each side. As shown in Figure 5-2, RAXIS may require lengthening if the arc fails to make contact with the abutments or if the central angle exceeds 120 degrees.

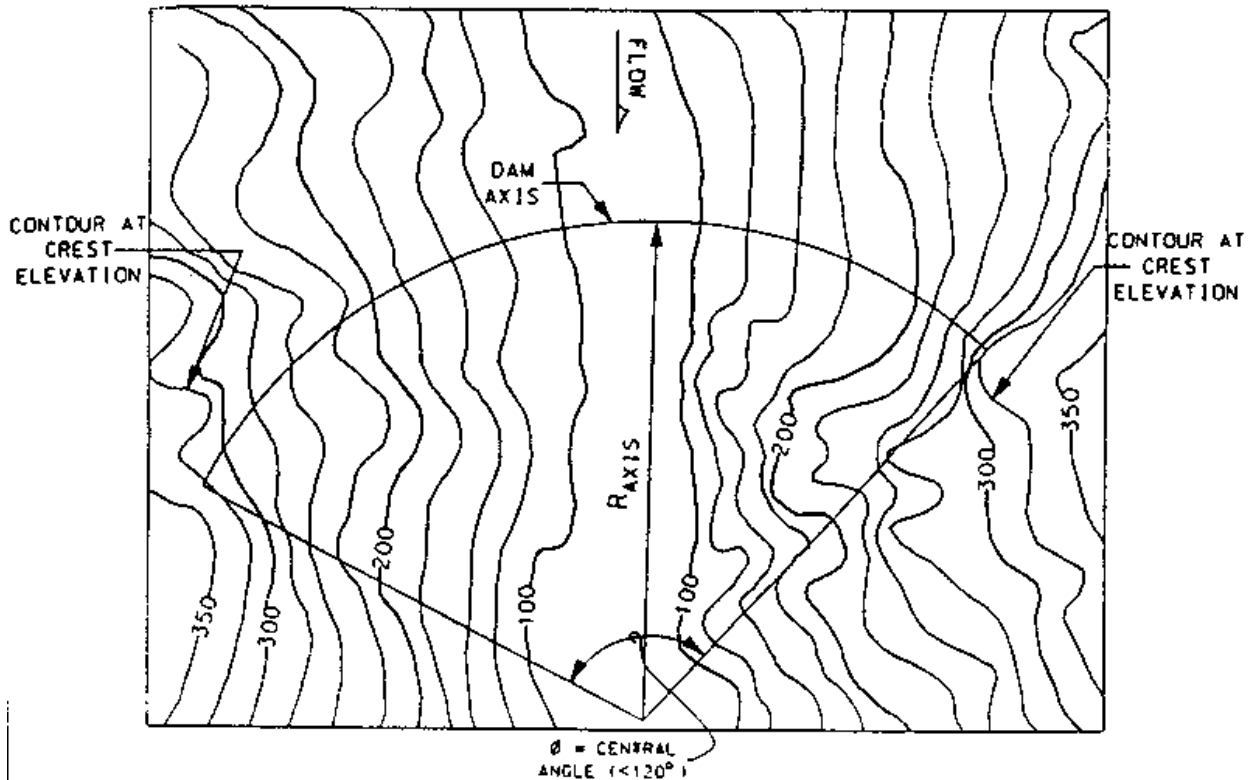

Figure 5-2

Layout of dam axis

4.1.2 THE MAGNITUDE OF THE CENTRAL ANGLE of the top arch is a controlling value which influences the curvature of the entire dam. Objectionable tensile stresses will develop in arches of insufficient curvature; such a condition often occurs in the lower elevations of a dam having a V-shape profile. The largest central angle practicable should be used considering that the foundation rock topography may be inaccurately mapped and that the arch abutments may need to be extended to somewhat deeper excavation than originally planned. Due to limitations imposed by topographic conditions and foundation requirements, for most layouts, the largest practicable central angle for the top arch varies between 100 and 120 degrees.

4.2 LOCATION OF CROWN CANTILEVER AND REFERENCE PLANE. On the overlay, locate the crown cantilever at the intersection of the dam axis and the lowest point of the site topography (i.e., the riverbed). This corresponds to the point of

maximum depth of the dam. A vertical plane passing through this point and the axis center represents the reference plane (or plane of centers). On the overlay plan, this plane is shown as a line connecting the crown cantilever and the axis center. Later, when arcs representing arches at other elevations are drawn, they will be located so that the centers of the arcs will be located on the reference plane. Ideally, the reference plane should be at the midpoint of the axis. This seldom occurs, however, because most canyons are not symmetrical about their lowest point.

4.3 CROWN CANTILEVER GEOMETRY. The geometry of the crown cantilever controls the shape of the entire dam and, as a result, the distribution and magnitude of stresses within the body. The empirical equations which follow can be used to define thicknesses of the crown at three locations; the crest, the base, and at el 0.45H above the base:

$$T_C = 0.01(H + 1.2L_1) \quad (5-2)$$

$$T_B = \sqrt[3]{0.0012HL_1L_2\left(\frac{H}{400}\right)^{\frac{H}{400}}} \quad (5-3)$$

$$T_{0.45} = 0.95T_B \quad (5-4)$$

4.3.1 IN ADDITION, UPSTREAM AND DOWNSTREAM PROJECTIONS of the extrados (upstream) and intrados (downstream) faces can also be arrived at empirically. Those relationships are:

$$USP_{CREST} = 0.0 \quad (5-5)$$

$$USP_{BASE} = 0.67T_B \quad (5-6)$$

$$USP_{0.45H} = 0.95T_B \quad (5-7)$$

$$DSP_{CREST} = T_C \quad (5-8)$$

$$DSP_{BASE} = 0.33T_B \quad (5-9)$$

$$DSP_{0.45H} = 0.0 \quad (5-10)$$

(Note: These empirical equations were developed by the USBR and are based on historical data compiled from existing dams. However, the engineer is not restricted to using the parameters derived from the empirical equations; they are presented as an aid for developing initial parameters and only for the first layout. Sound engineering judgement resulting from experience obtained in arch dam layout may also be utilized when defining an initial layout or refining a previous one. Values for subsequent layouts will consist of adjustments, usually by engineering evaluation of stress analysis, of the values used in the previous iterations.)

4.3.2 AS SHOWN, THE UPSTREAM AND DOWNSTREAM projections at the crest, base, and at el 0.45H above the base can now be plotted in elevation in reference to the dam axis. This plot is referred to as the "plane of centers" view. The next step is to define the upstream and downstream faces of the crown cantilever using a circular arc (or combinations of straight lines and circular arcs) which passes through the upstream and downstream projection points as shown in Figure 5-4. With the faces defined in this

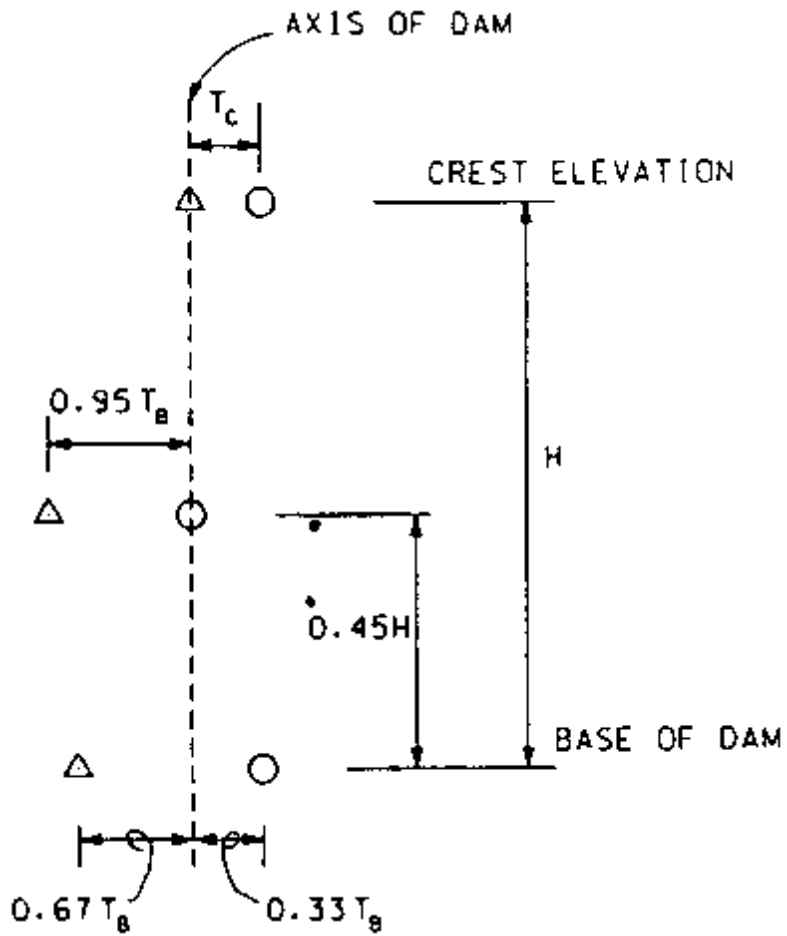

Figure 5-3
Empirically derived projections of the crown cantilever

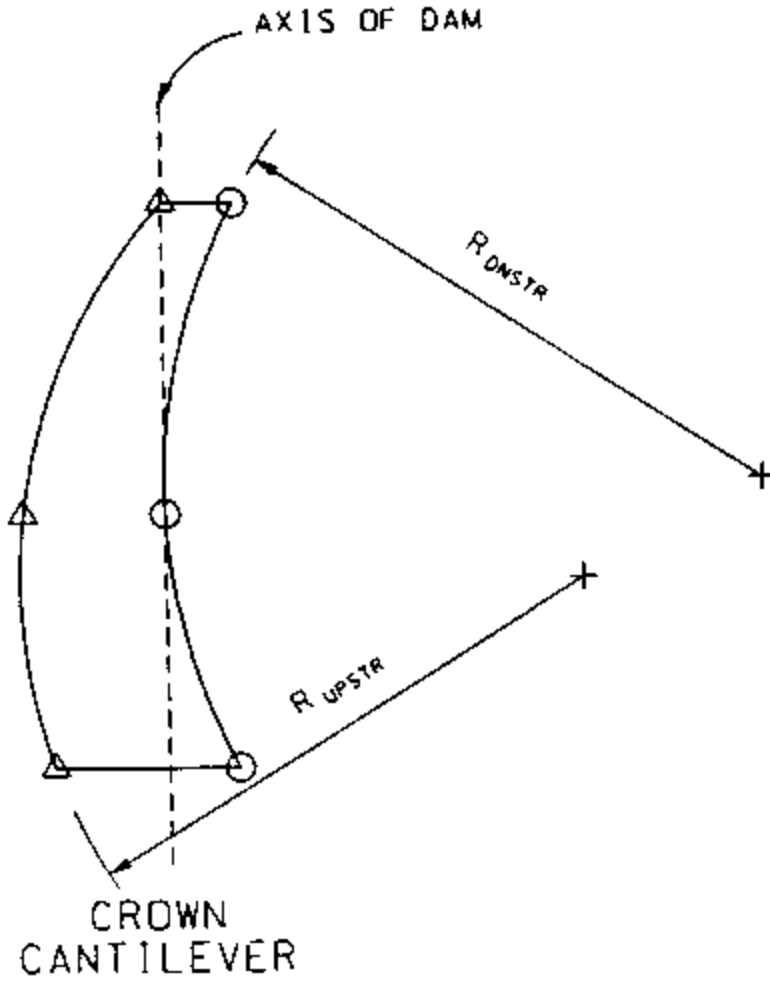

Figure 5-4
Definition of upstream and downstream faces

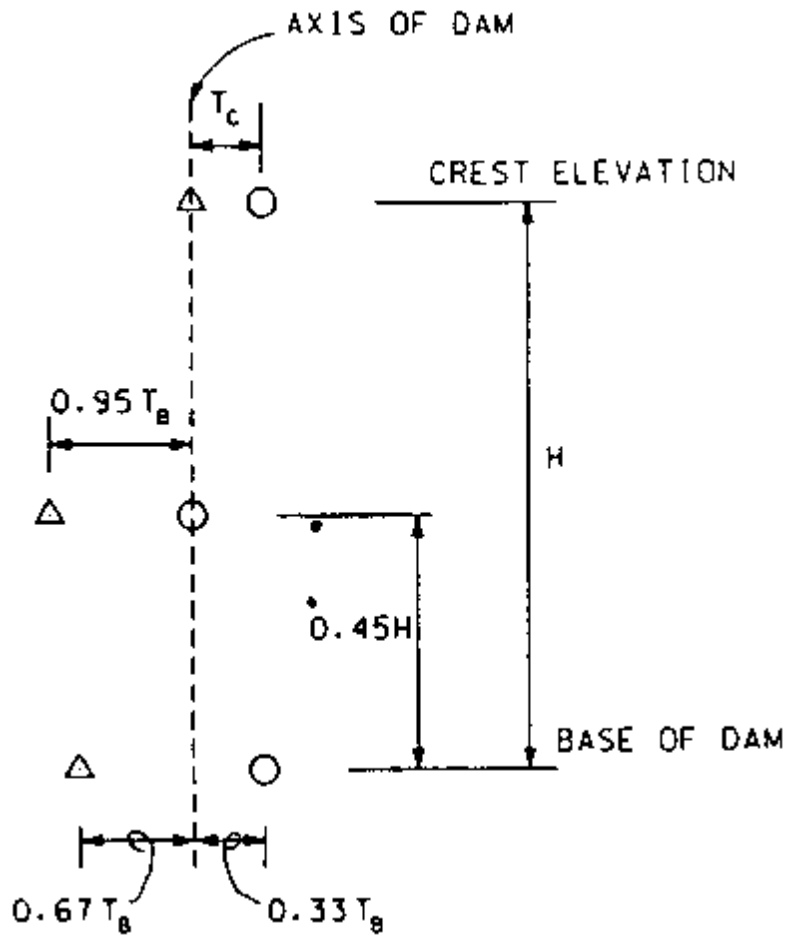

Figure 5-3

Empirically derived projections of the crown cantilever

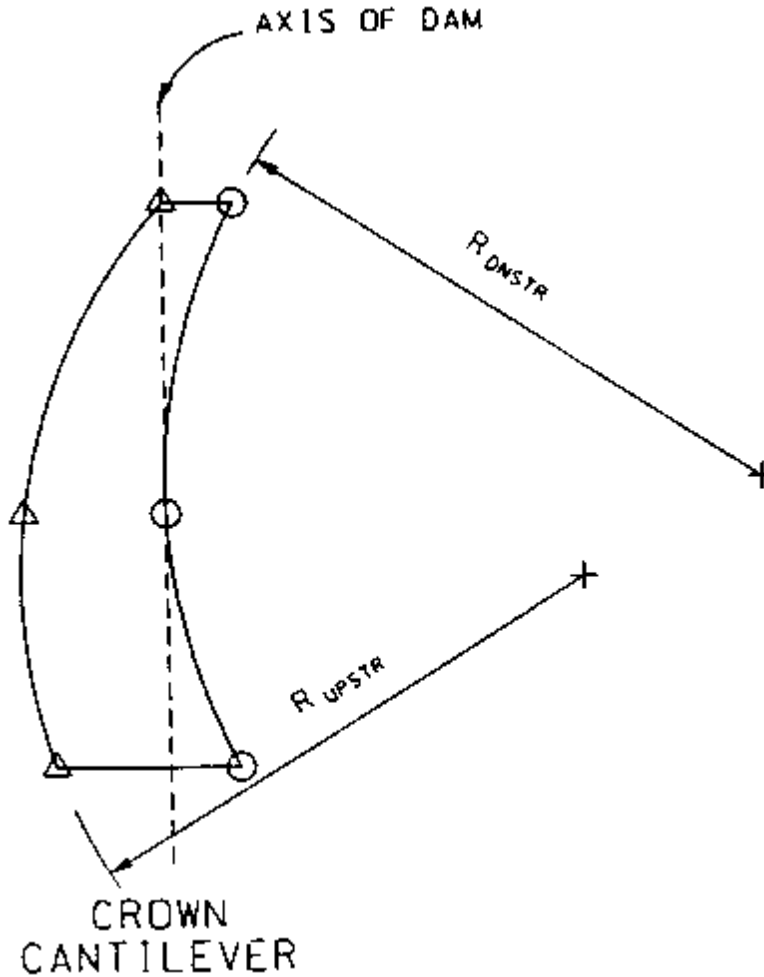

Figure 5-4
Definition of upstream and downstream faces

manner, upstream and downstream projections at any elevation can be obtained. This information will be necessary when laying out the arches.

4.4 ESTIMATING THE DAM FOOTPRINT. The axis of the dam on the topographic overlay corresponds to the upstream face of the dam at the crest. An arc representing the downstream face of the crest can be drawn with the center of the arc at the axis center and a radius equal to R_{AXIS} reduced by the thickness at the crest, TC . On the plan overlay, three points are identified to aid in laying out the contact line between the foundation and the upstream face of the dam. Two of the points are the intersection of

the axis of the dam with the foundation contour at the crest elevation at each abutment (points A and B). The third point is the upstream projection of the crown cantilever at the base. This point can be plotted in reference to the axis of the dam based on information taken from the plane of centers view (Figure 5-5). Using a french curve, a smooth curve is placed beginning at the upstream face of the crest on one abutment, passing through the upstream projection of the crown cantilever at the base (point C), and terminating at the upstream face of the crest at the other abutment (points A and B in Figure 5-6).

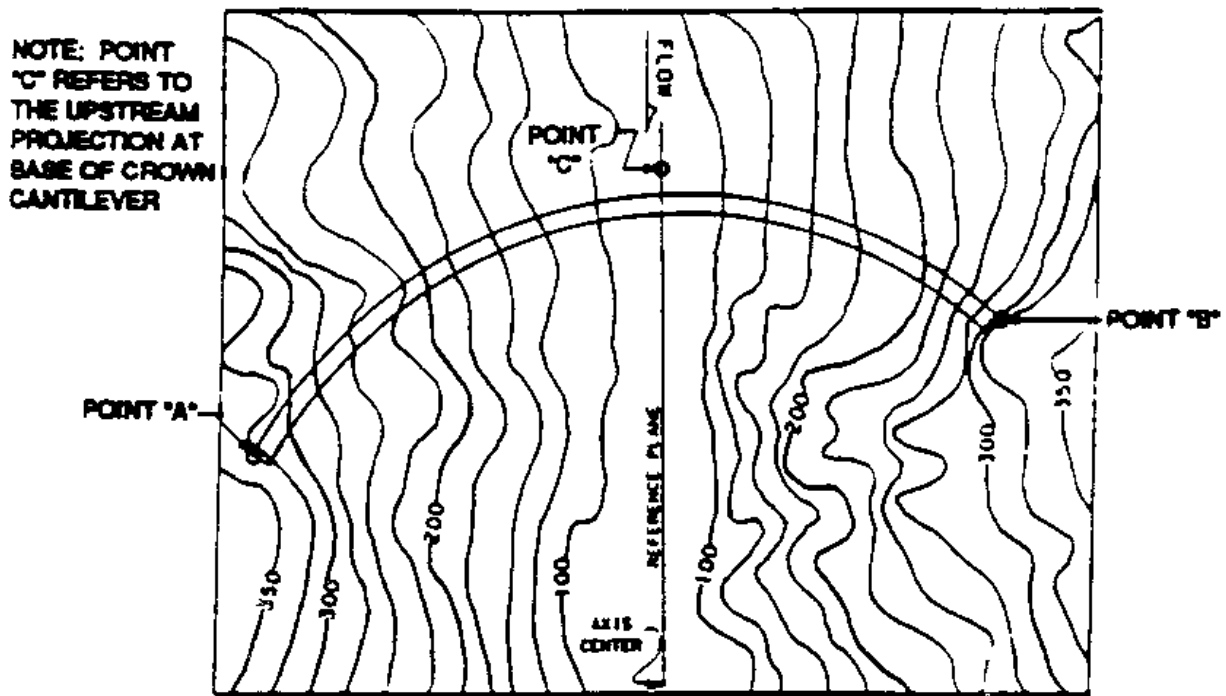

Figure 5-5

Contact points between dam and foundation at crest and crown cantilever

4.5 LAYOUT OF THE ARCHES. Of all that is involved in arch dam layout, this step is possibly the most difficult. For shaping and analysis purposes, between 5 and 10 evenly spaced horizontal arches are drawn. These arches should be spaced not less than 20 feet nor greater than 100 feet apart. The lowest arch should be 0.15H to 0.20H above the base of the crown cantilever.

4.5.1 BEGINNING AT THE ARCH IMMEDIATELY below the crest, determine, from the plane of the centers view, the upstream and downstream projections of the crown cantilever at that specific arch elevation. These projections are then

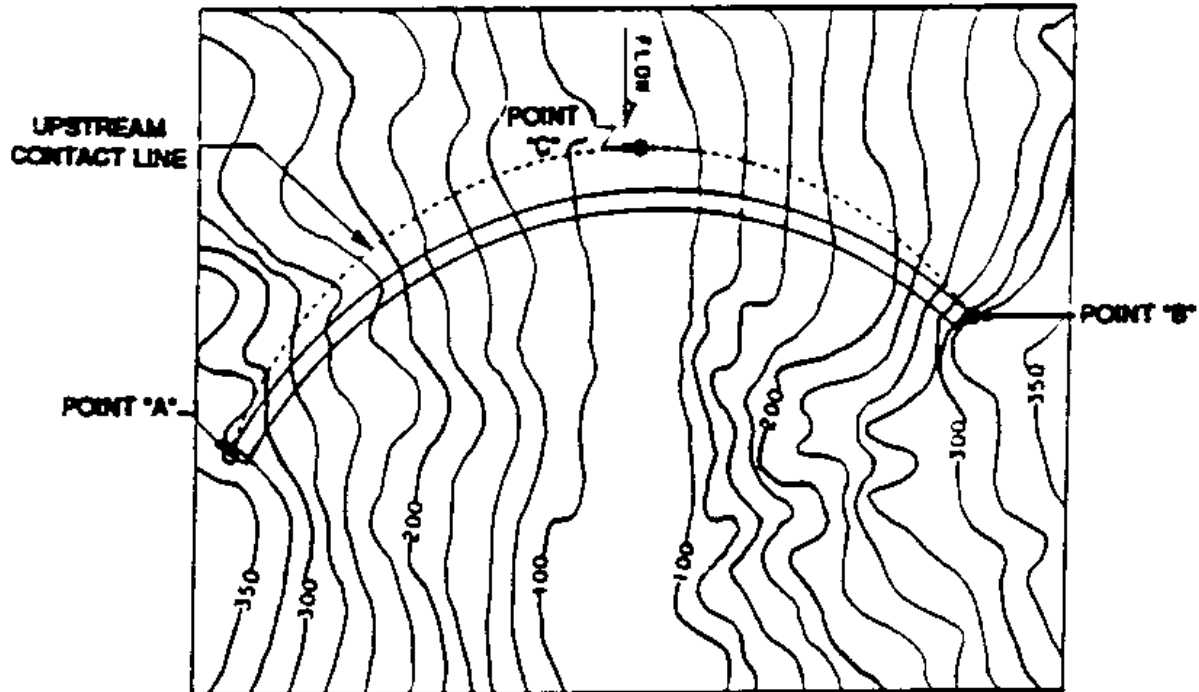

Figure 5-6

Upstream contact line at dam-foundation interface

plotted on the plan view along the reference plane. Using a beam compass, trial arcs representing the upstream face of the dam at that specific arch elevation are tested until one is found which meets the following criteria:

4.5.1.1 THE ARC CENTER must lie along the reference plane.

4.5.1.2 THE ARC MUST PASS through the upstream projection of the crown cantilever as plotted on the plan view.

4.5.1.3 BOTH ENDS OF THE ARC MUST TERMINATE on the upstream contact line at a foundation elevation equal to or slightly deeper than the arch elevation.

4.5.2 LOCATING AN ARCH WHICH SATISFIES all of these criteria is a trial and error process which may not be possible with a single-center layout. This is generally the case when dealing with unsymmetrical canyons where different lines of centers are required for each abutment. Figure 5-7 shows an example of an arch that meets the criteria. Of particular importance is that the ends of the arch must extend into the abutments and not fall short of them. This ensures that a "gap" does not exist between the dam and foundation.

4.5.3 THIS PROCEDURE IS REPEATED to produce the downstream face of the arch. Similar to what was performed for the upstream face, the downstream projection of the crown cantilever is determined from the plane of centers view and plotted on the plan view. The beam compass is then used to locate an arc that meets the three criteria with the exception that the arc must pass through the downstream projection of the crown cantilever with ends that terminate on the radial to the extrados at the abutment (Figure 5-7). If the same arch center is used for the upstream and downstream faces, a uniform thickness arch is produced. If the arch centers do not coincide, the arch produced will vary in thickness along its length (variable thickness arch).

4.5.4 ONCE A SATISFACTORY ARCH HAS been produced, the locations of the arch centers for the upstream and downstream face are marked along the reference plane on the plan view. Standard practice is to identify the extrados (upstream) face with a triangle and the intrados (downstream) face with a circle. The corresponding arch elevation should be identified with each. Although these arch centers appear to lie on a straight line in plan, they all are positioned at their respective arch elevations, and it is highly unlikely that they are on a straight line in three dimensional (3-D) space.

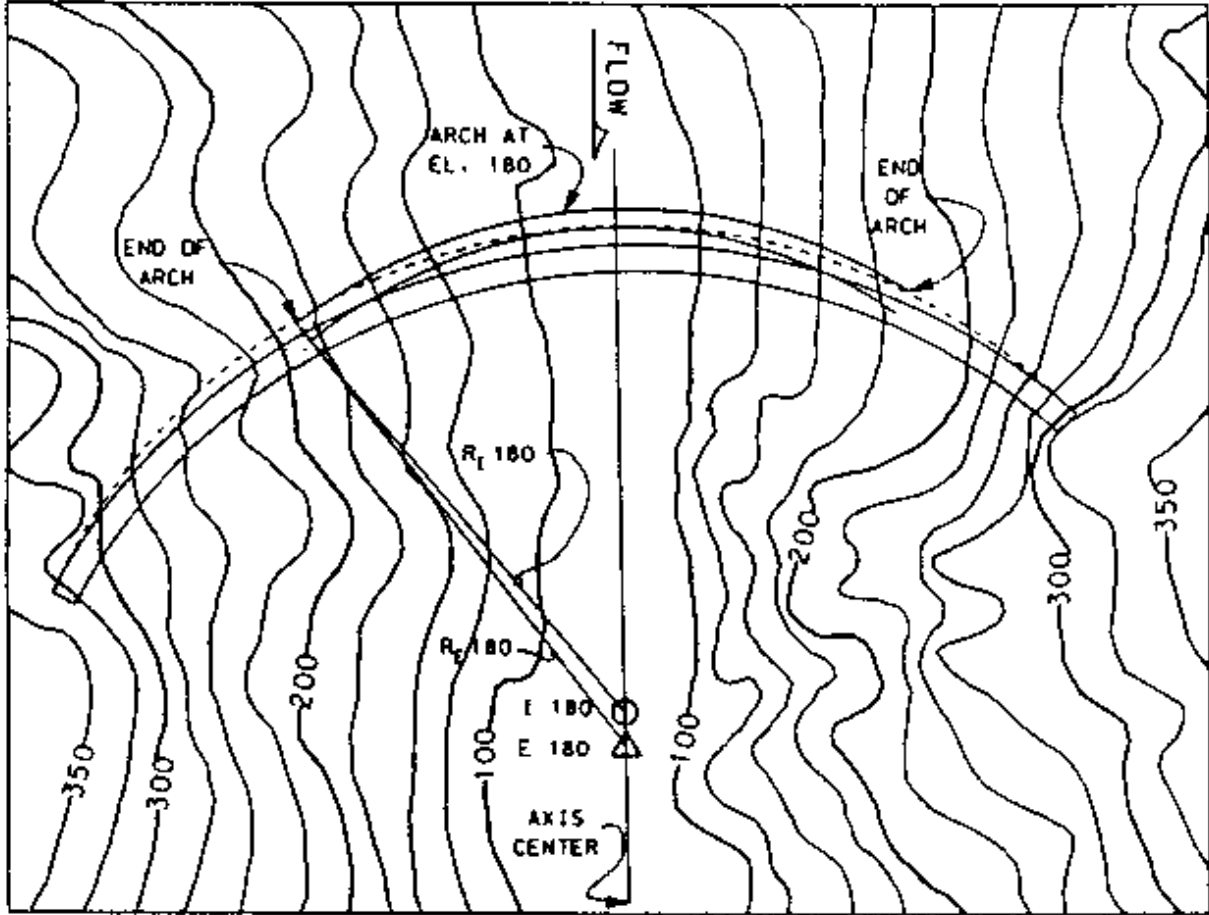

Figure 5-7

Typical layout of an arch section arch

4.5.5 ARCHES AT THE REMAINING elevations are plotted in similar fashion. Of particular importance to producing an acceptable plan view is to ensure that the footprint, when viewed in plan, is smooth and free flowing with no abrupt changes or reverse curvature. This requirement is usually met by the fact that a footprint is predetermined; however, endpoints of arches may not terminate exactly on the footprint. Revision of the footprint is necessary to ensure that it passes through all actual arch endpoints prior to checking it for smoothness.

4.6 REVIEWING THE LAYOUT. Layout of an arch dam includes the preparation of three different drawings. The first is the plan view, which begins with locating a crest

and ends with plotting the arches. The second drawing is a section, in elevation, along the reference plane, called the plane-of-centers view. This view has been partially produced when the crown cantilever was created, but it requires expansion to include the lines of centers. The third drawing to be produced is a profile (looking downstream) of the axis of the dam and the foundation. Proper review includes examining all views for "smoothness," because abrupt changes in geometry will result in excessive stress concentrations. The term "smoothness" will be discussed in the following paragraph. Only when the plan view, plane of centers, and profile demonstrate "smoothness" and are in agreement is the layout ready for preliminary stress analysis. It should be pointed out that all three views are dependent on each other; when making adjustments to the geometry, it is impossible to change parameters in any view without impacting the others.

4.6.1 CREATING AND REVIEWING THE PLANE-OF-CENTERS VIEW. In addition to the crown cantilever, the plane of centers also includes the lines of centers for the upstream and downstream face. A section is passed along the reference plane in plan to produce the plane-of-centers view. Each arch center, upstream and downstream, is plotted in elevation in reference to the axis center, as shown in Figure 5-8. The lines of centers are produced by attempting to pass a smooth curve through each set of arch centers (Figure 5-9). These lines of center define the centers for all arches at any elevation. If the curve does not pass through the arch centers located during the arch layout procedure, those arch centers will be repositioned to fall on the appropriate line of centers. Those particular arches will require adjustment on the plan view to reflect the change in position of the arch center. The structural engineer should understand that this adjustment will involve either lengthening or shortening the radius for that particular arch which will impact where the ends of the arch terminate on the abutments. Lines of centers should be smooth flowing without abrupt changes and capable of being emulated using combinations of circular curve and straight line segments, as shown in the example on Figure 5-10. The circular arcs and straight line segments used to define the lines of centers will be input into ADSAS when performing the preliminary stress analysis.

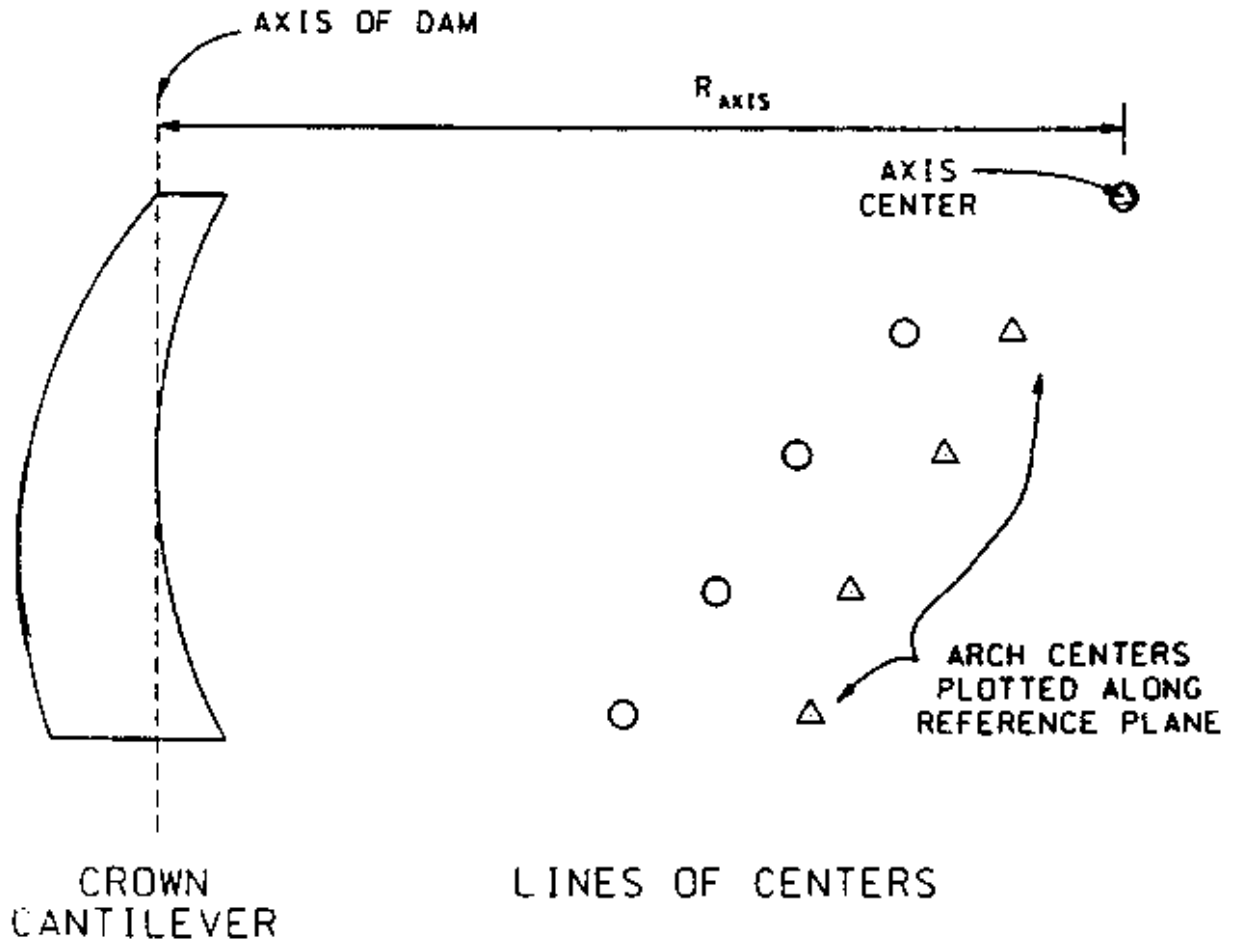

Figure 5-8
Plotting of arch centers along reference

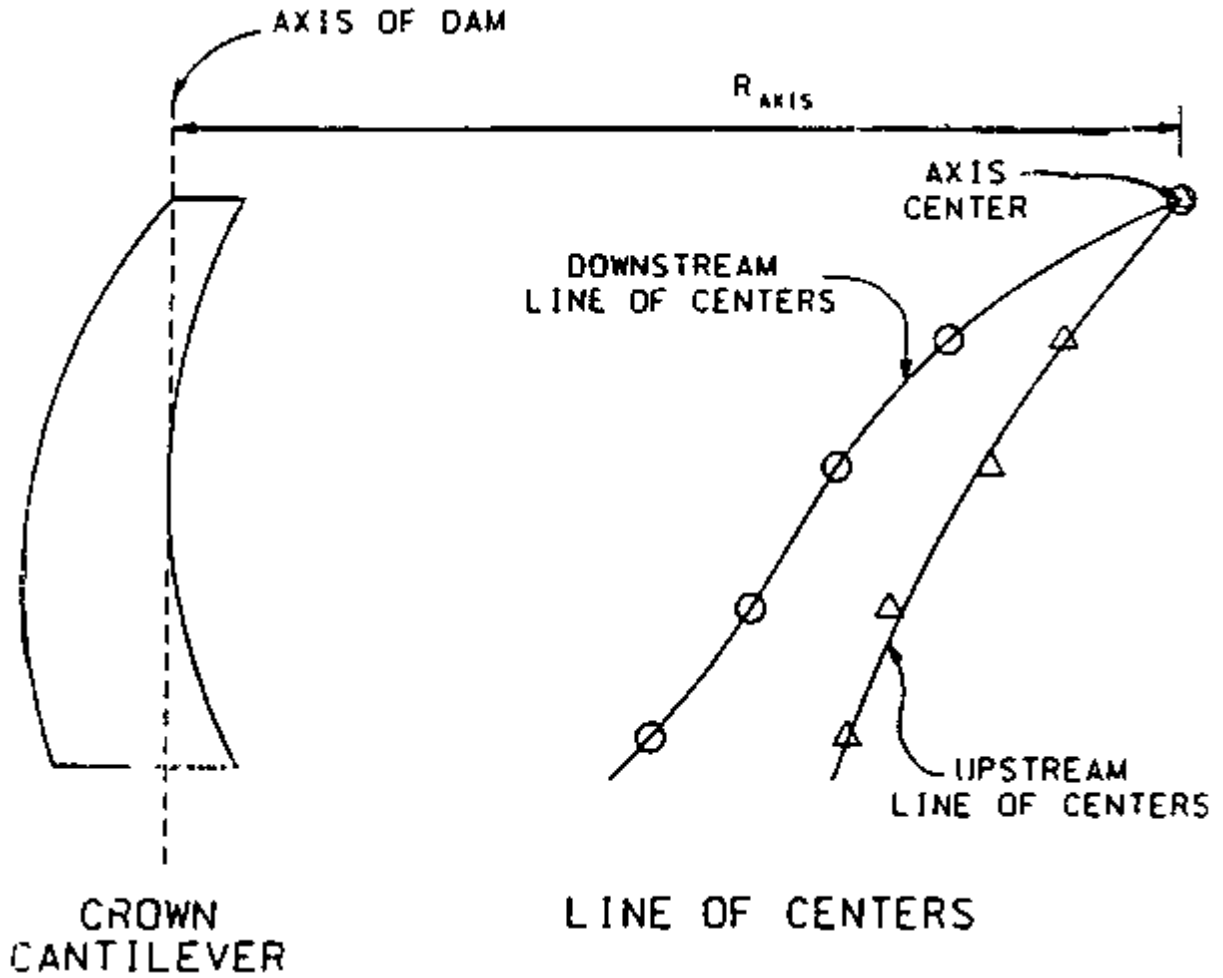

Figure 5-9
Development of the lines of centers

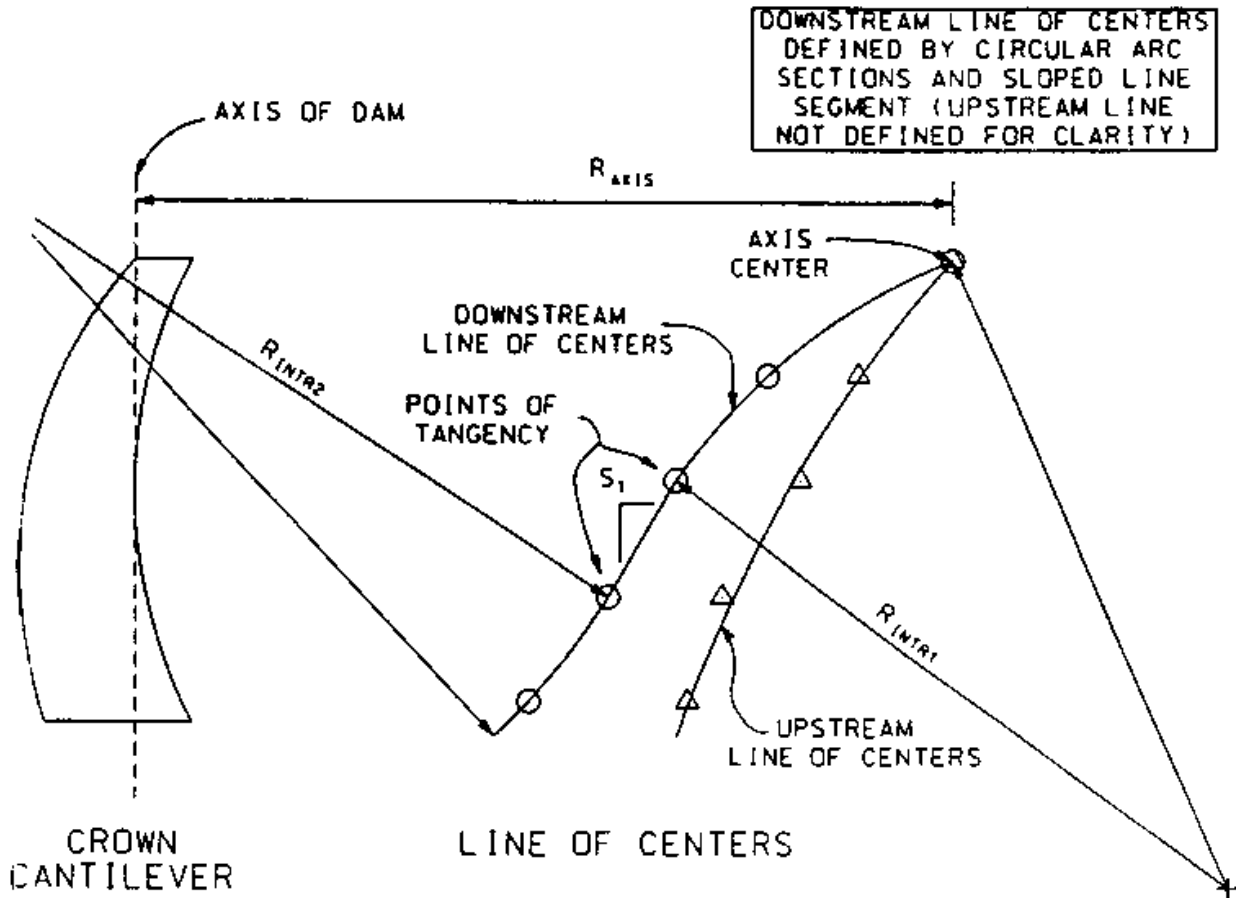

Figure 5-10
Defining the lines of centers

4.6.2 DEVELOPING THE PROFILE VIEW. Once a satisfactory plan view and plane-of-centers view has been obtained, the profile view is ready to be created. The profile view is used to examine the amount of excavation that a particular layout has induced. The profile view consists of a developed elevation of the upstream face of the dam (looking downstream) with the foundation topography shown. It should be noted that this is a developed view rather than projection of the upstream face onto a flat plane. This "unwrapping" results in a view in which no distortion of the abutments exists. Figures 5-11 and 5-12 show, respectively, examples of acceptable and unacceptable profiles.

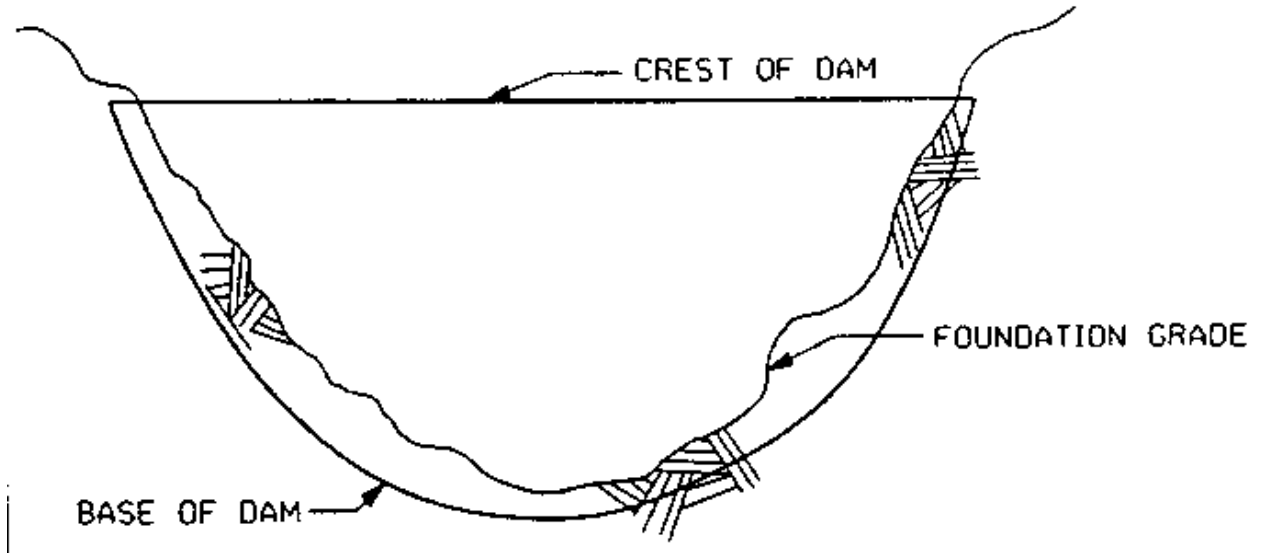

Figure 5-11

Example of an acceptable developed profile view

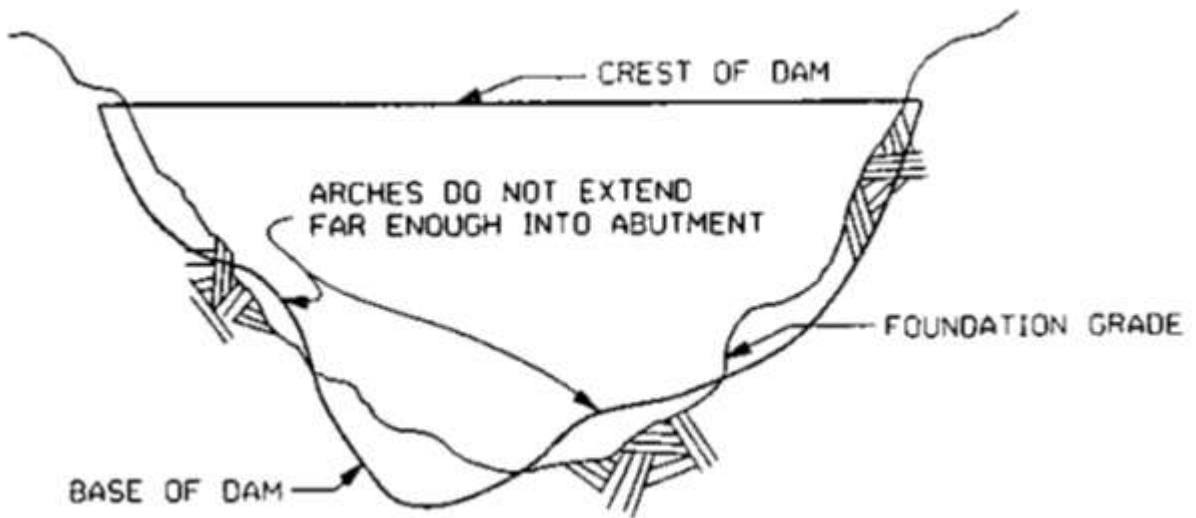

Figure 5-12

Example of an unacceptable developed profile view

4.6.3 FOUNDATION OF DAM. In general, the foundation of the dam should be as the lines of centers: smooth and free flowing with no abrupt changes in geometry. The base of the dam must also extend into the foundation; otherwise, an undesirable condition develops in that "gaps" will occur between the base of the dam and the foundation, requiring foundation treatment. Pronounced anomalies should be removed by reshaping the affected arches until a smooth profile is obtained.

5. PRELIMINARY STRESS ANALYSES. After a satisfactory layout has been obtained, a preliminary stress analysis is performed to determine the state of stress of the dam under various loading conditions. The computer program ADSAS was developed by the USBR (1975) for this purpose. The Corps of Engineers adapted ADSAS for use on a microcomputer. ADSAS is based on the trial load method of analysis. A discussion on the theory of the trial load method is beyond the scope of this document; however, the USBR (1977) addresses this topic in detail.

5.1 ADSAS INPUT. While an exact description of the steps necessary to prepare an input data file for ADSAS is documented in the operations manual (USBR 1975) and a Corps of Engineers' manual. A brief description is included here. A typical ADSAS input data file contains four groups of information: a geometry definition section, material properties, loading conditions, and output control cards.

5.1.1 GEOMETRY DEFINITION. Critical to the success of obtaining an accurate analysis is the ability to convey to the program the geometry which defines the shape of the arch dam. This geometry consists of:

5.1.1.1.1 CROWN CANTILEVER GEOMETRY. Base elevation, crest elevation, projections of the upstream and downstream faces at the crest and the base, X and Y coordinates, and radii of all circular arcs used in defining the upstream and downstream faces, and slopes of any straight line segments used in defining the upstream and downstream faces.

5.1.1.2 LINES-OF-CENTERS GEOMETRY. Axis radius, X and Y coordinates and radii of any circular arcs used in defining all lines of centers, slopes of any straight line segments used in defining all lines of centers, elevations at intersections between segments defining lines of centers, and horizontal distances from axis center to intrados and extrados lines of centers.

5.1.1.3 ARCH GEOMETRY. Elevations of all arches, angles to abutments for all arches, and angles of compound curvature. All data required for the crown cantilever and lines of centers geometry are taken from the planes-of-centers view while data required for the arch geometry should be available from the plan view.

5.1.2 MATERIALS PROPERTIES. ADSAS analysis also requires material properties of both the concrete and the foundation rock. These data include modulus of elasticity of the concrete and foundation rock, Poisson's ratio for the concrete and foundation rock, coefficient of thermal expansion of the concrete, and unit weight of concrete.

5.1.3 LOADING CONDITIONS. During layout, only static loading conditions are analyzed. ADSAS is capable of analyzing hydrostatic, thermal, silt, ice, tailwater loads, and dead weight.

5.1.4 OUTPUT CONTROL. ADSAS provides the user with the ability to toggle on or off different portions of the output to control the length of the report while capturing pertinent information.

6. EVALUATION OF RESULTS. Evaluation requires a thorough examination of all the analytical output. Types of information to be reviewed are the crown cantilever description, intrados and extrados lines of centers, geometrical statistics, dead load stresses and stability of blocks during construction, radial and tangential deflections and angular deformations, loading distributions, arch and cantilever stresses, and principal stresses. If any aspect of the design is either incorrect or does not comply with established criteria, modifications must be made to improve the design.

6.1 RESULTANT COMPONENTS. Evaluation of the arch dam may also include examination of the resultants along the abutments. These resultants are separated into three components; radial, tangential, and vertical. The combined radial and tangential resultant should be directed into the abutment rock. In the lower arches, that abutment may tend to parallel the surface contours or daylight into the canyon. Prudent engineering suggests that the resultant be turned into the abutment. The solution may be a combination of increasing stiffness in the upper arches or flexibility in the lower arches. The effect is mitigated by including the vertical component which then directs the total resultant downward into the foundation.

6.2 VOLUME OF CONCRETE. One major factor of a layout that requires evaluation is the volume of concrete that is generated. ADSAS computes this volume as part of its output. If a quantity is desired without proceeding through a preliminary stress analysis (as for a reconnaissance layout), that value can be arrived at empirically by the following equation.

$$v = 0.000002H^2L_2 \frac{(H + 0.8L_2)}{L_1 - L_2} + 0.0004HL_1 [H + L_1] \quad (5-11)$$

The volume of concrete calculated in ADSAS or derived from Equation 5-11 does not reflect mass concrete in thrust blocks, flip buckets, spillways, or other appurtenances.

7. IMPROVEMENT OF DESIGN. The best of alternative designs will have stresses distributed as uniformly as possible within allowable limits combined with a minimum of concrete. Where to terminate a design and accept a final layout based on these criteria are difficult in some dams with widely varying loading conditions, such as with a flood control dam which has periods of low and high reservoir elevations. The primary means of effecting changes in the behavior of the dam is by adjusting the shape of the structure. Whenever the overall stress level in the structure is far below the allowable limits, concrete volume can be reduced, thereby utilizing the remaining concrete more efficiently and improving the economy. Following are some examples of how a design can be improved by shaping.

7.1 LOADS AND DEFLECTIONS. Load distribution and deflection patterns should vary smoothly from point to point. Often when an irregular pattern occurs, it is necessary to cause load to be shifted from the vertical cantilever units to the horizontal arches. Such a transfer can be produced by changing the stiffness of the cantilever relative to the arch.

7.2 RESHAPING ARCHES. If an arch exhibits tensile stress on the downstream face at the crown, one alternative would be to reduce the arch thickness by cutting concrete from the downstream face at the crown while maintaining the same intrados contact at the abutment. Another possibility would be to stiffen the crown area of the arch by increasing the horizontal curvature which increases the rise of the arch.

7.3 RESHAPING CANTILEVERS. When cantilevers are too severely undercut, they are unstable and tend to overturn upstream during construction. The cantilevers must then be shaped to redistribute the dead weight such that the sections are stable. Severe overhang will cause tension to develop on the upper upstream face, contraction joints in the affected area to close, and prevent satisfactory grouting.

7.4 FORCE-STRESS RELATIONSHIP. Shaping is the key to producing a complete and balanced arch dam design. The task of the designer is to determine where and to

what degree the shape should be adjusted. Figure 5-13 should be used to determine the appropriate changes to be made to the structural shape. If an unsatisfactory stress condition is noticed, the forces causing those stresses and the direction in which they act can be determined by Figure 5-13. For example, the equations of stress indicate which forces combine to produce a particular stress. Knowing the force involved and its algebraic sign, it is possible to determine its direction from the sign convention shown on the figure. With that information the proper adjustment in the shape can be made so that the forces act to produce the desired stresses.

8. PRESENTATION OF DESIGN LAYOUT. Figures and plates that clearly show the results of the design layout and preliminary stress analyses should be included in the FDM. Plates that illustrate and describe the detailed geometry of the arch dam include:

8.1 PLAN VIEW. Arches, arch centers, angles to the abutments, axis center, dam-foundation contact line, and dam orientation angle are some items that are included in this view of the dam overlaid on the site topography.

8.2 SECTION ALONG REFERENCE PLANE. This plate includes all the information that defines the vertical curvature of the crown cantilever and the line(s) of centers (Figure 1-6).

8.3 CANTILEVER SECTIONS. All cantilevers generated during the preliminary stress analysis should be shown. Showing the thickness at the base and at the crest of each cantilever is also recommended as shown in Figure 5-14.

8.4 ARCH SECTIONS. Arch sections generated as a result of the preliminary stress analysis should be plotted. Appropriate thicknesses at the reference plane and at each abutment should be shown for each arch as shown in Figure 5-15.

8.5 PROFILE. A profile, developed along the axis of the dam, should be presented, showing locations of cantilevers and the existing foundation grade as shown in Figure 5-16.

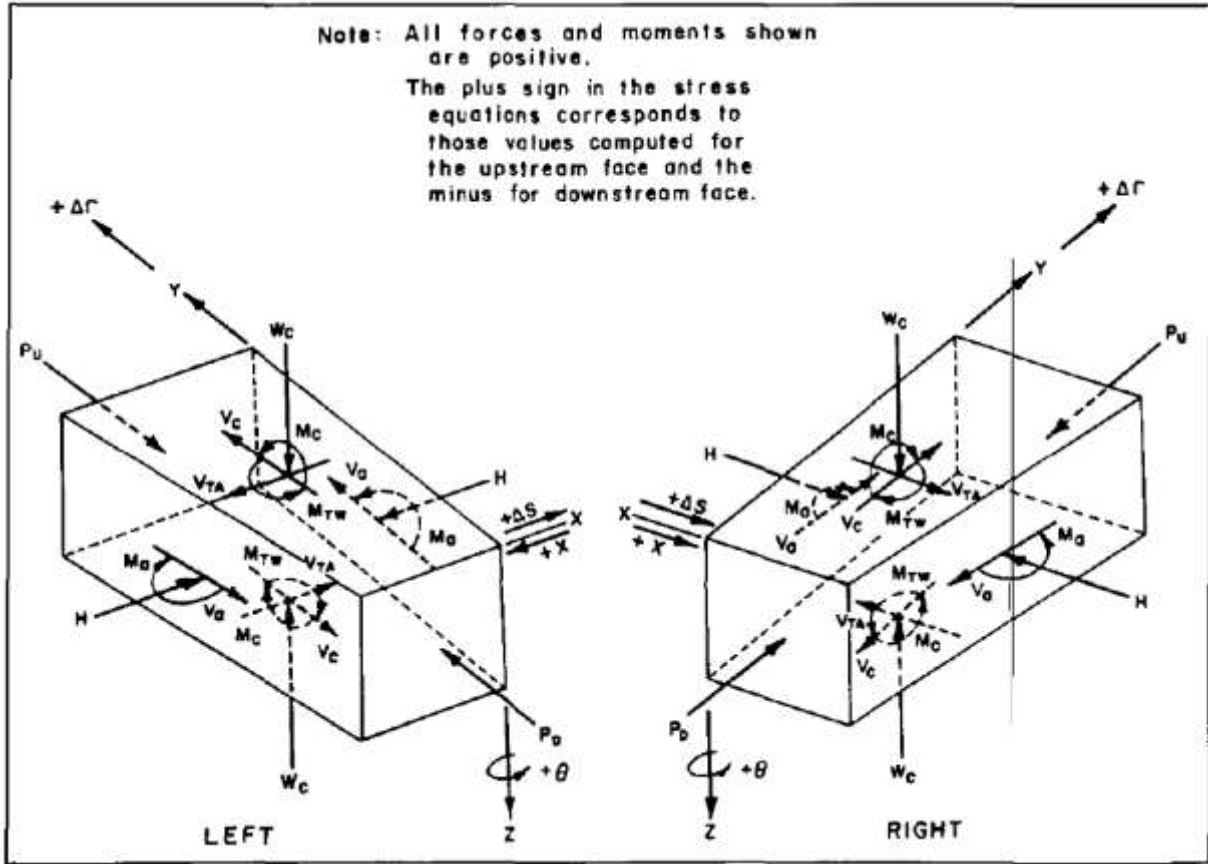

Figure 5-13

Sign convention for arch computations in ADSAS

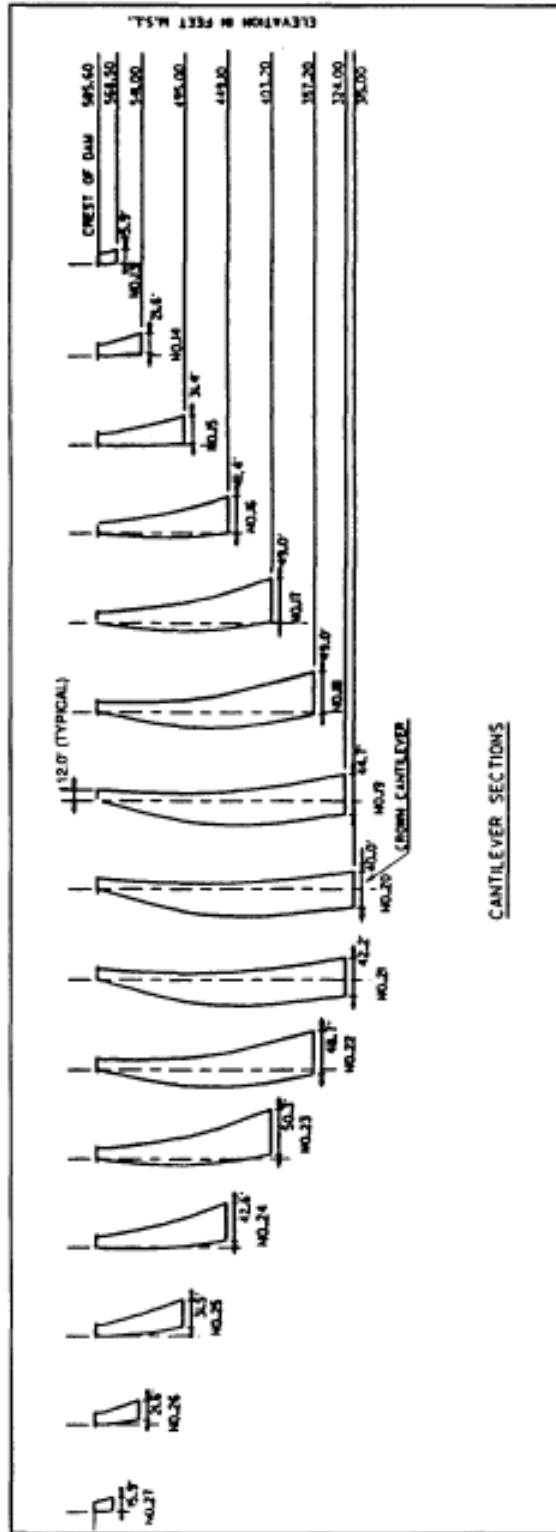

Figure 5-14
Cantilever sections

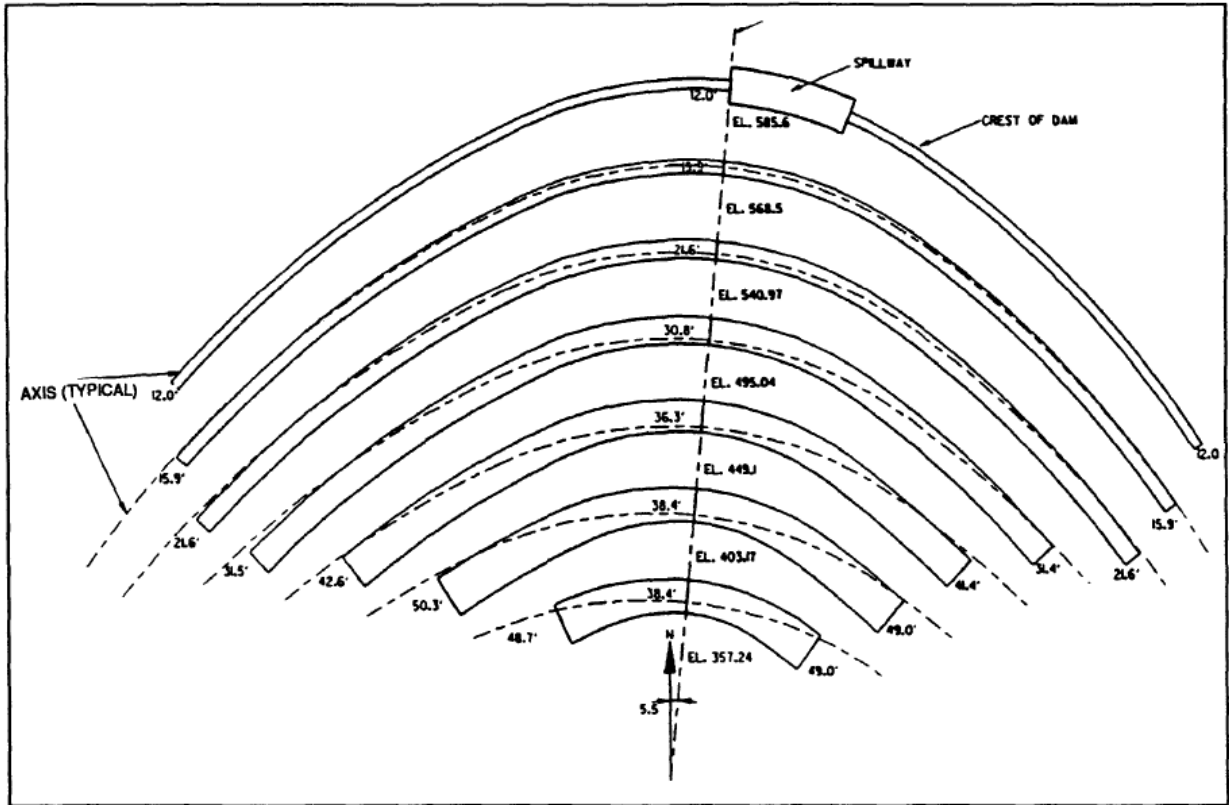

Figure 5-15. Arch sections

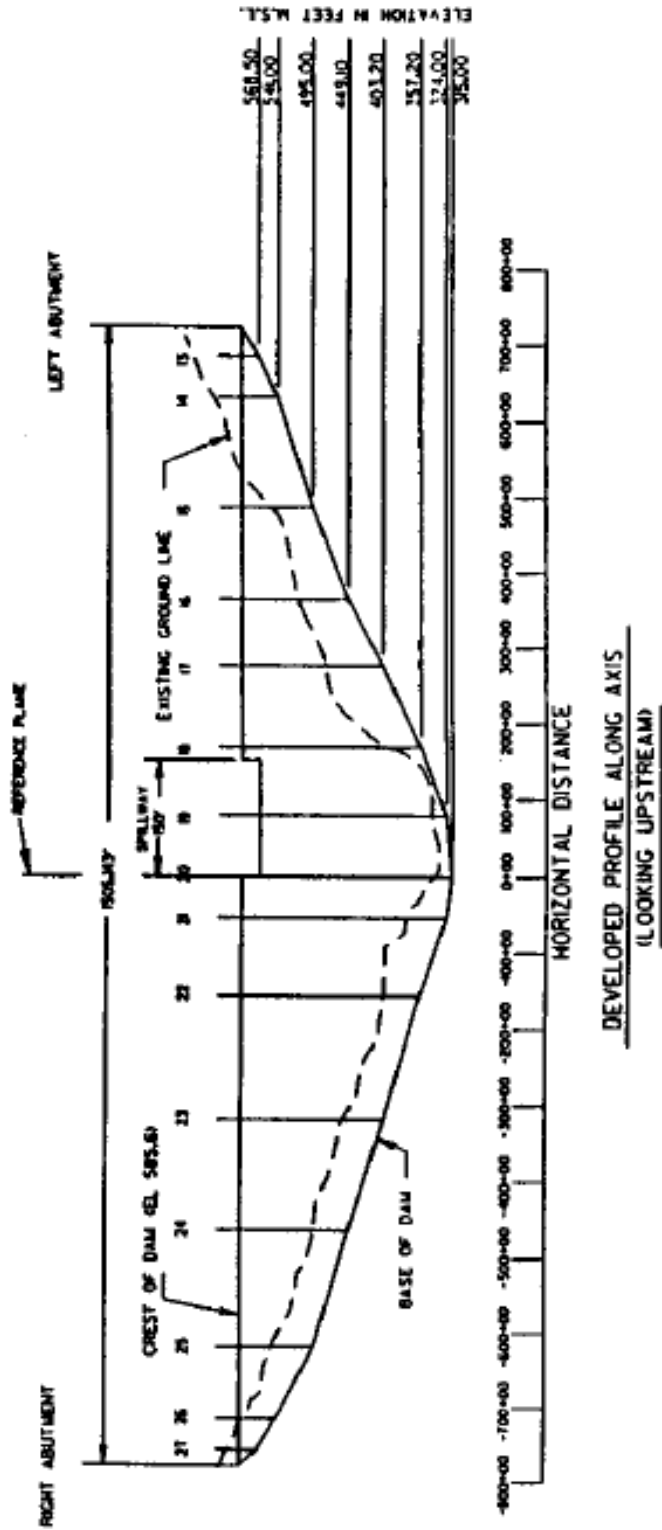

Figure 5-16
Developed profile

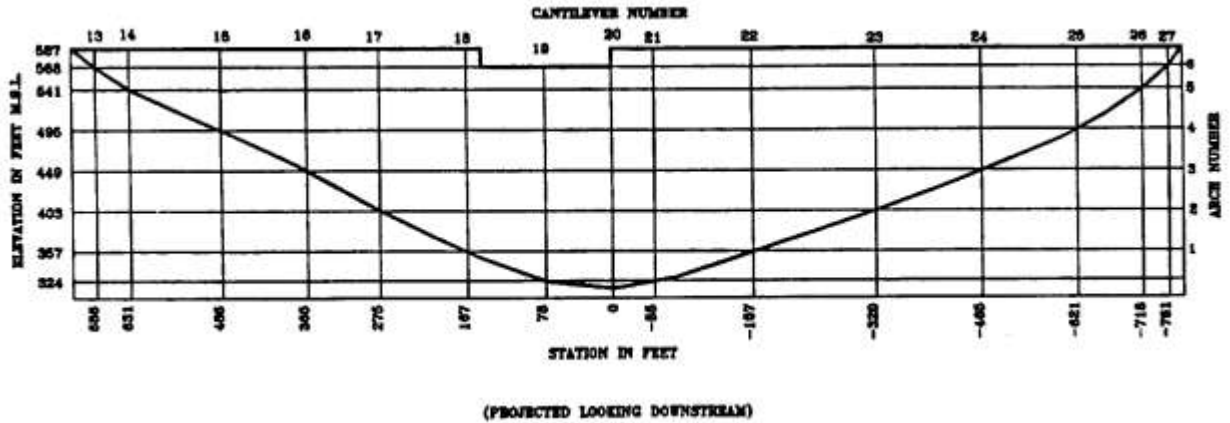

Figure 5-17
ADSAS model

8.6 ADSAS MODEL. A plot showing the model of cantilever and arch units generated by ADSAS and the associated cantilever and arch numbering scheme is plotted and shown in the FDM as shown in Figure 5-17.

8.7 STRESS CONTOURS. Contour plots of arch and cantilever stresses on the upstream and downstream faces for all load cases are presented in the FDM as shown in Figure 5-18.

8.8 DEAD LOAD STRESSES. Stresses produced in the ungrouted cantilevers as a result of the construction sequence should be tabulated and presented in the FDM as shown in Figure 5-19.

9. COMPUTER-ASSISTED LAYOUTS. The procedures mentioned in this chapter involve manual layout routines using normal drafting equipment. As mentioned, the iterative layout procedure can be quite time consuming. Automated capabilities using desktop computers have been developed which enable the structural designer to interactively edit trial layouts while continuously updating plan, plane of centers, and profile views. When an acceptable layout is achieved, the program generates an ADSAS data file which is input into a PC version of ADSAS. In all, developing these tools on a desktop computer allows the structural designer to proceed through the layout process at a faster rate than could be achieved manually, thereby, reducing design time and cost.

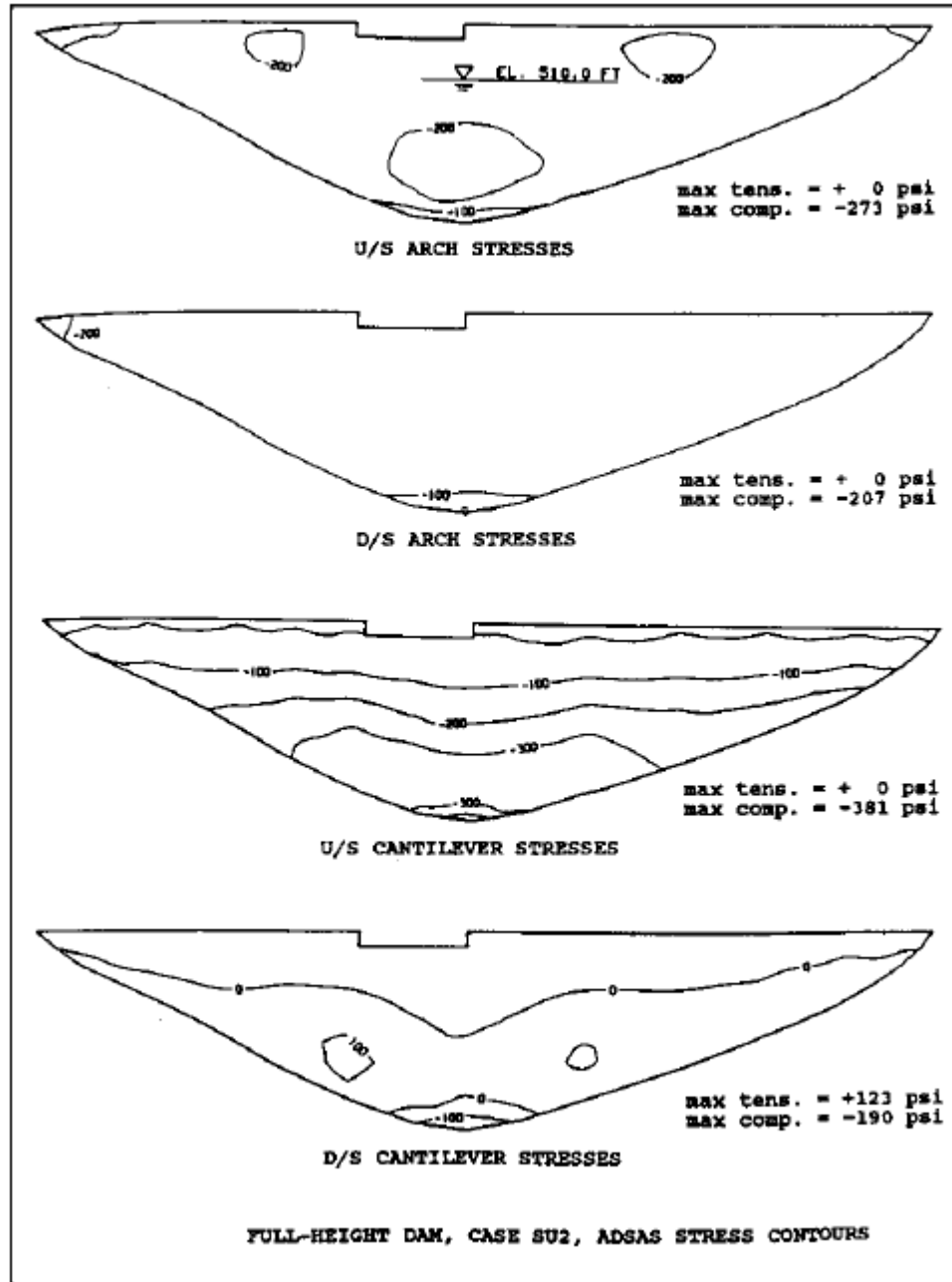

Figure 5-18
ADSAS stress contours

MINIMUM DEAD LOAD STRESSES (IN PSI) BY CANTILEVER				
CANTILEVER NUMBER	STRESS BASED ON CONCRETE PLACED ON	ELEVATION OF MINIMUM STRESS	MINIMUM DOWNSTREAM STRESS	UPSTREAM FACE STRESS
20	495.04	314.96	48	-406.
21	540.97	324.00	66.	-459.
22	587.20	357.24	142.	-483.
23	587.20	403.27	111.	-357.
24	587.20	449.10	80.	-265.
25	587.20	495.04	61.	-197.
26	587.20	540.97	18.	-95.
27	587.20	567.20	-2.	-35.
19	540.97	324.00	103.	-482.
18	587.20	357.24	156.	-496.
17	587.20	403.17	89.	-340.
16	587.20	449.10	37.	-227.
15	587.20	495.04	15.	-152.
14	587.20	540.97	5.	-81.
13	587.20	567.20	-6.	-32.

NOTE: MINUS SIGN INDICATES COMPRESSION

Figure 5-19
Dead load stresses