



PDHonline Course E130 (3 PDH)

Introduction to Digital Process Control and Industrial Data Communication for Process Control

Instructor: Thomas Mason, P.E.

2020

PDH Online | PDH Center

5272 Meadow Estates Drive
Fairfax, VA 22030-6658
Phone: 703-988-0088
www.PDHonline.com

An Approved Continuing Education Provider

Introduction to Digital Process Control and Industrial Data Communication for Process Control

Course Content

To successfully apply automatic controls along with centralized supervisory control and monitoring, one must be intimately familiar with the characteristics of the process. For this reason, examples are included for commercial HVAC, small parts manufacture and assembly, steel processing and chemical processing. It is the user's responsibility, to provide the content expertise to make his application of automatic controls and SCADA work.

The principles of automatic control are not intuitive until many demonstrations have been fully understood. For this reason, many primitive automatic control demonstrations are included here and reference is made to real-life situations which involve automatic control.

The application of automatic control requires identification of a reliable commercial device which can watch what is happening and make adjustments. The watching and adjusting are sensors and actuators, which will be introduced, with limited examples studied in detail.

The control function is in-the-box. Today, the box is a 1/4 DIN (German Industrial Standard) enclosure, about 4-in(w) x 4-in(h) by 6-in deep, with fancy stuff on the front and terminals and a data connector on the back and a computer inside. The SCADA is a communications cable from the controller to a pc which displays, alarms, trends, archives and automatically or manually adjusts the controller. Again, samples of each will be studied in some detail.

These principles, some underlying definitions and examples are illustrated and addressed after the system graphics below:

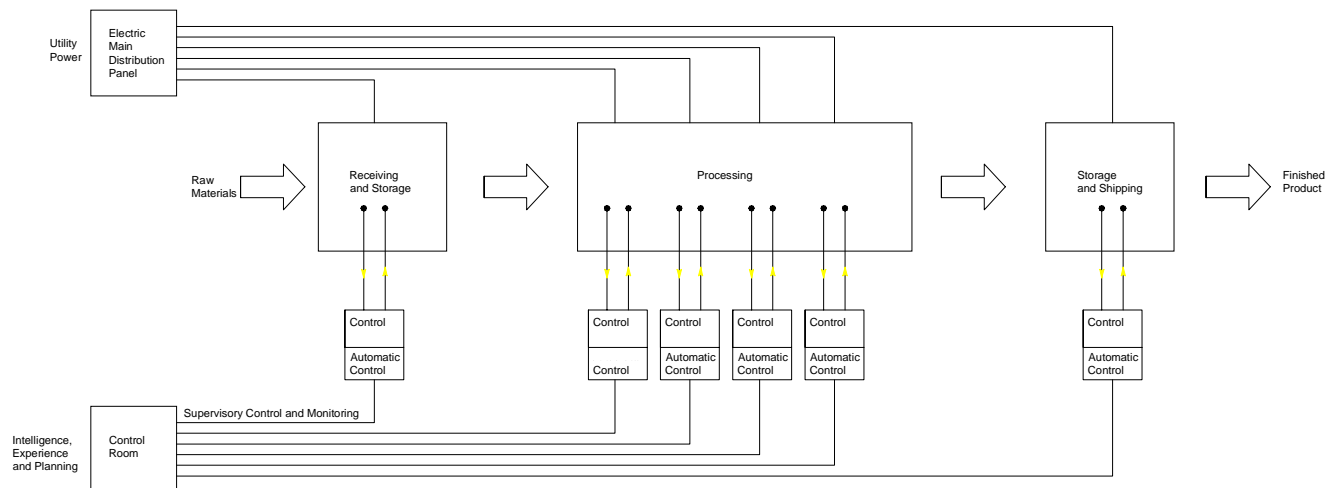

Industrial Plant Process Flow and Control Architecture

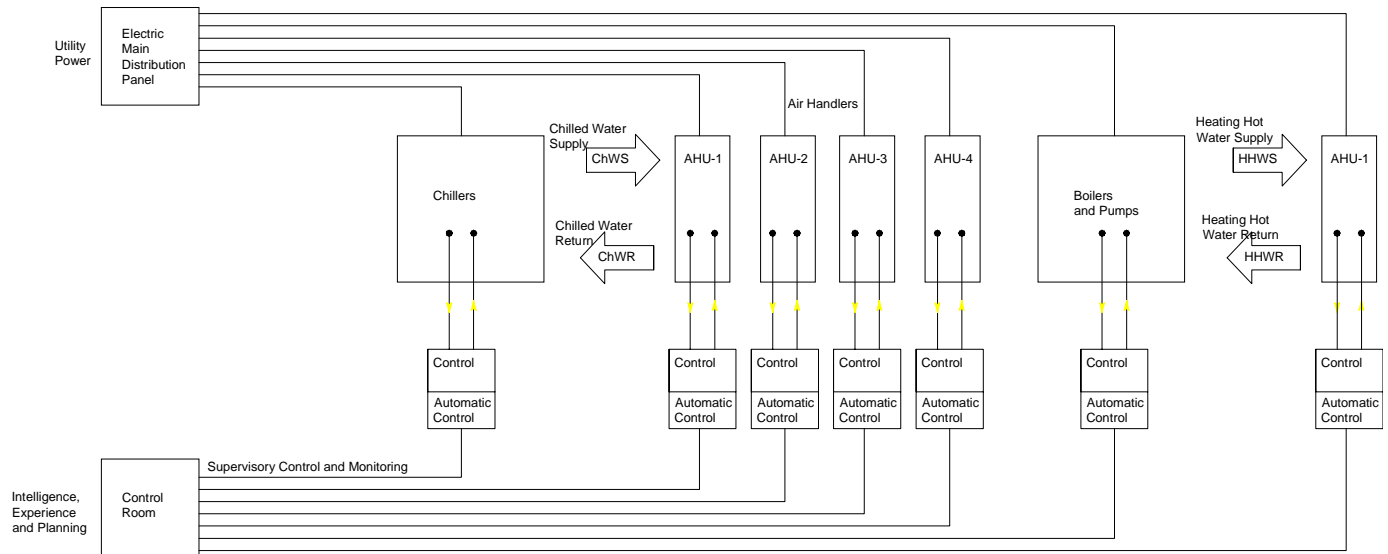

Office or School HVAC Process Flow and Control Architecture

[Somebody is already complaining that these systems were created by a plant electrical engineer who thinks that electrical maintenance should run the plant and electrical maintenance should run all HVAC. The intended message is that electric cables from a central location to each piece of major equipment is already in place and there are tradesmen on staff or on contract who know their way around the equipment and around the facility. Automatic controls and SCADA are extremely powerful, flexible, inexpensive tools which can be installed, configured and operated by any plant personnel with foresight and motivation. Use the plant electrical engineer, but don't abuse him.]

The following topics will be discussed in some detail:

- Project justification - Why would anyone pay for supervisory control and SCADA?.
- Manual control - Turning stuff on and off at the right time is not really easy.
- Simplified single loop control - Turning stuff on and off can be done automatically if you can define the rules in terms of measurable parameters.
- Looking more closely at single loop control - Automatic control is a lot more complicated than it appears. Fortunately, much is performed without intervention or adjustment, in software.
- Control schemes not discussed, advanced control concepts, cascade control, multi-loop control, predictive control or formal hazard assessment - There is a rule about not discussing what you are not discussing. It is violated here.
- Sensors - It can be very valuable to centrally count machine operations and alarm off machine alarms. It is essential to measure something being controlled automatically - the computer doesn't know when to stop if you don't tell it.
- Actuators - We have 150 years of development of devices that take a small operation and use it to open valves, lift loads and start fans and pumps. It is a very small step to connect the computer to do this.

- Permissive control logic - There is an art to keeping the operator "in the loop" while protecting the system.
- Control alarms - is the automatic control working?
- Single-loop controllers - We have 50 years of fabricating boxes that take in values from sensors, put out values for actuators, tell you what they are doing on the front panel and do good stuff inside the box.
- Tuning proportional controllers - There are three adjustments, Proportional, Integral and Differential. Set all three to zero, no effect. Increase Proportional to suit. Never touch Integral or Differential.
- Centralized controllers (DCS), not - Somebody got the idea of putting all the controls for a plant in a central computer and calling it distributed control. A sophisticated industry developed. Concurrently, other people created personal computers and arranged for the pc's, anywhere in the plant, to view and sometimes adjust the process. The second evolution is the one discussed in this course. For the first, check out the Honeywell Controls, Foxboro Controls and Bailey Controls links at the end of the course.
- Dedicated control subsystems - From 1950 to 1980, innovators were discovering how to automatically control tank levels, boiler firing rate, bleach concentration, bottling machines and lathes. These techniques are well documented and incorporated in machine controls. The dedicated control subsystems, however, can benefit greatly from monitoring and supervisory control.
- Installation of automatic controls - This is not a cookbook for technicians. It does contain, however, some tips on rapid, economical installation.
- Installation of standard machine monitoring - Carefully think through one installation, then copy it everywhere.
- Installation of standard monitoring marshalling panel - You can run dedicated 120V and instrumentation cables from the machine to the monitor console. But, for nearly the same money, you can put in remote i/o and a single data cable for all present and future monitoring.
- Installation of data communications cables - This course recommends hiring a cable installer. They are experienced, careful, readily available, and cheap. On the other hand, some tips on cable installation are included.
- Installation of centralized supervisory control and monitoring - If you can unpack a laptop computer, install MicroSoft OFFICE and get it running, you can install and startup centralized supervisory control and monitoring. If you pay someone to get your computer going, he has exactly the skills you need to get centralized supervisory control and monitoring going. Consider the firm's IT department, a high school intern or a computer store technician working on the side. There are firms specializing in control systems who will charge you \$500 to talk about it and \$1,000 a day to work on it.
- Features of commercial human-machine interface software (HMI) - Commercial HMI packages look good. In addition they are extremely functional in display, alarming, archiving and analysis tools.

- Application examples - A mid-size plant that makes rubber balls and toys monitors machine production and alarms. A large state university supervises proprietary HVAC controls. A small city monitors water treatment and distribution and waste water collection and sewage plants from town hall. A large city monitors transit station security centrally and eliminates roving guards.

Each of these concepts and components will be discussed in some detail, followed by a discussion of problems and solutions associated with field installation.

Project justification - Why would anyone pay for supervisory control and SCADA?

- There are two keys to economic installation of supervisory control and monitoring - leveraging existing infrastructure and proactive management. The hardware has dropped in cost into the \$100-500 range per location, but the communications system duplicates telephone and data systems and can be extremely expensive, especially inter-building links if infra-red sighting is not possible. Jump on the existing data network using TCP/IP equipped controllers and the communications cost suddenly approaches zero.

Why would management pay to send out a technician to fix an air handler before the classroom teachers call in complaints? Firstly, because it is cheaper to tell a technician at the beginning of his shift that he has to repair a damper problem than to send him out just before morning break to find out what the problem is. The monitoring system narrows the range of the problem, just as the preliminary visit does. Scheduling from information gathered overnight utilizes labor better and may correct the problem before any classes start and complaints develop.

Secondly, some university administrations have decided that declining enrollments can be reversed by improving the reputation of the institution. They undertake surveys to determine the problems recognized by students. Uncomfortable classrooms are best remedied by monitoring and normal management pressure on maintenance groups to improve the summary numbers.

Why would a manufacturing concern pay to report machine failures in the maintenance supervisor's office? Well, by definition, maintenance staff is limited. Again, without question, some production machines are critical, whereas others can be out of service for a day or week without loss. Combine these two concepts and it is obvious that pulling a repair crew off a low priority job and sending them to a high priority job is valuable. Repair crews have carried radios for a long time. The early notification of high priority failures has been the problem.

Manual control - In our minds, "turning stuff on" is simple. Off-On. On the plant floor or in the mechanical room it is much more complicated. Turning on an extruder or blow-molding machine first requires that parts get up to temperature. Turning on an air handler fan requires that the fire dampers open first

Even starting a pump requires that both the suction and discharge valves be opened first, and when a pump starts there is a major electrical event of inrush current and a major mechanical event of impulse flow.

An even greater problem is WHEN to turn on the stuff. To get perimeter hot water heat to work, you must turn on the pump and open the valve. You have to turn on the pump

sometime in September. In January, you have to open the valve every thirty minutes; if the valve sticks open the room overheats and there is a problem. Yes, a local thermostat should open and close the valve, but a valve stuck open stays open until the phone calls to maintenance get a response.

Most factories have a small discharge waste water unit. Sometimes as simple as a sump pump, but often including a separation tank and a holding tank if something bad happens. Nobody likes to check to see if the float switches are working or the last position the valves were left in.

Simplified single loop control - There are many forms of automatic loop control. (*Loop* means a sensor, a target value, or *setpoint*, an operator and some logic. A float switch and a pump complete a control loop. The float senses high level and starts the pump. As the level drops, the float switch senses return to normal and turns off the pump. There is also some logic in the motor to shut it off from overheat and let the tank overflow.)

A simple discrete loop senses off-on events and usually controls by turning on and off an operator. The pump-down float control just described is a discrete control loop. The floats are off-on. The pump is off-on. [It is possible to control off a single float, but there is a hazard of short-cycling, when the tank fill is very slow. The tank fills a little; the float switches; the pump turns on and draws down the tank, but the float switches back and the pump turns off immediately. Big pumps shouldn't be started more than 10 times per hour. The problem can be overcome with a special float which includes *deadband*, a substantial space between a single float switching on and switching off.]

A simple proportional loop senses a process value, perhaps from 0-100%. The actuator has a range of response, also, perhaps 0-100%. The logic tries to find a value of command to the actuator to cause the process value to match the *setpoint*. Caution, in the real world, there is no reason to think that 65% actuator will produce 65% process value. Pumps are very different from valves and the piping system changes periodically.

Looking more closely at single loop control - Let's add alarms without making anything more complicated. [A serious implied question is, who will notice the alarms and do something?]

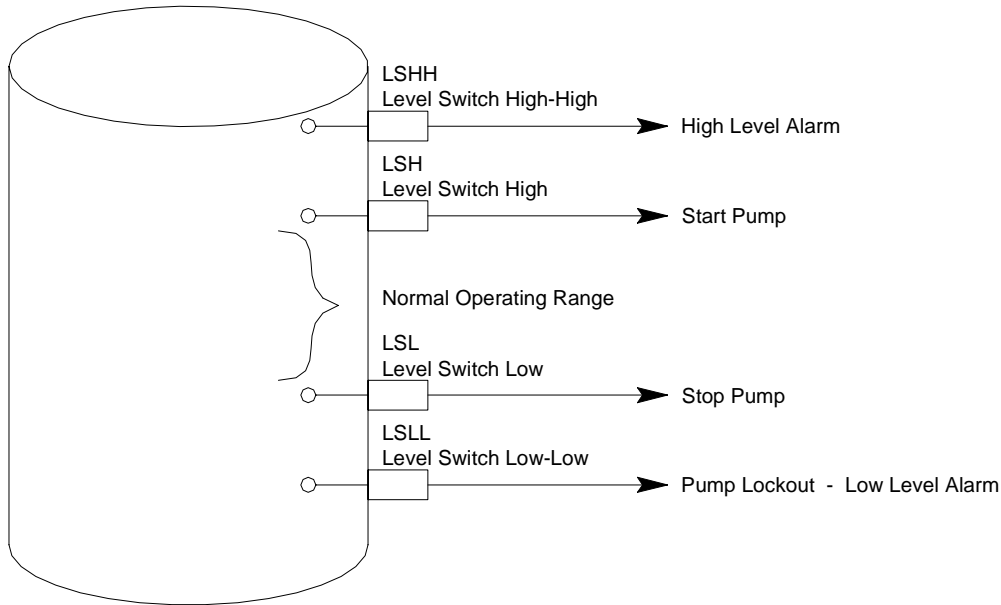

Discrete Pump Down Control Loop Sensors and Logic with Alarms

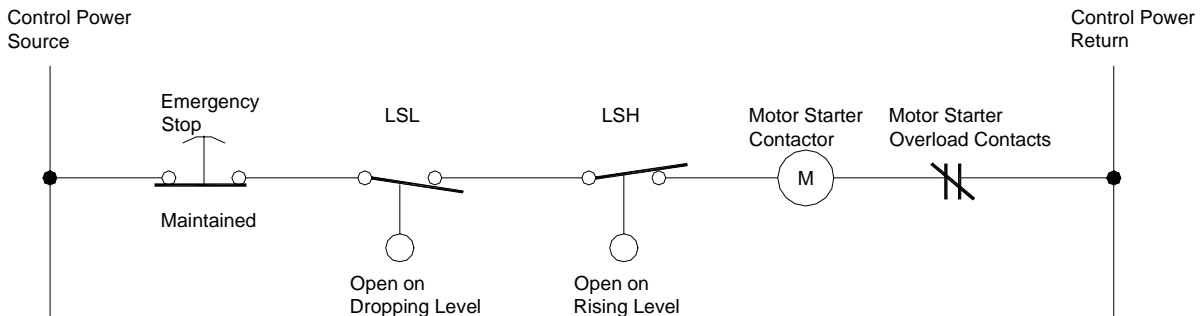

Discrete Pump Down Control Loop Control Logic Ladder Diagram

The top graphic is referred to as an Instrument Diagram, usually including the controller symbol and the actuator symbols. More examples and an extended set of instrument symbols are included as an Appendix to this course.

The bottom graphic is referred to as a Ladder Diagram, sometimes including the pump motor, motor starter and control power transformer. More examples and an extended set of ladder diagram symbols are included as an Appendix to this course.

The vertical lines on the ladder diagram used to be labeled "120V" and "N". There is a growing trend, however to move to 24VDC for control power. The automotive industry has decided that 24VDC is safer for operators and maintenance persons; it is compatible with low-cost, high-reliability programmable logic controller (PLC) discrete inputs and outputs, and, it can directly operate all but the largest motor starters directly.

An extremely common simple proportional control loop is temperature control, as a furnace or heated tank.

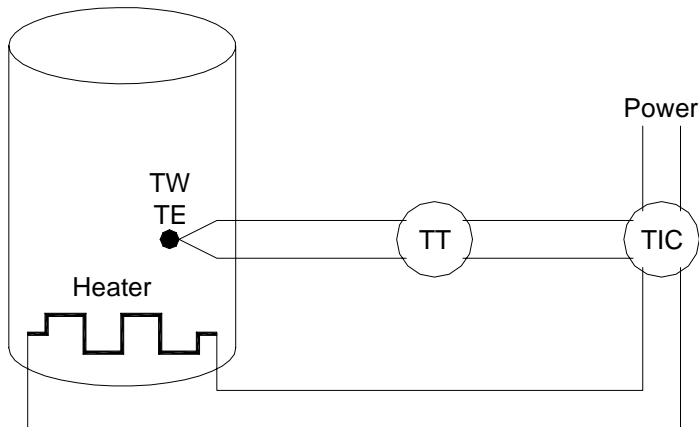

Proportional Temperature Control Loop Instrument Diagram

The symbols and presentation here are not quite standard. (See the symbols lists in the Appendix.) TW is a sealed temperature well, permitting the temperature sensing element, TE, to be inserted into the tank shown from a convenient external point. TT is a temperature transmitter. This was a common device in the old days to convert the mV level of the TE to a 24VDC, mA signal, which could travel long distances to a central control panel or control room. Very long mV signal leads are now used with little trouble, controllers are placed near the process, and it is all replaced by a \$100 plc remote i/o block or \$500 plc.

The TIC, temperature indicating controller, is a sophisticated device which has benefited from the solid state revolution and economies of scale in manufacturing. For \$300, you get a dedicated microprocessor, input terminals for your choice of temperature element, output terminals to directly drive a \$10 power solid state relay or to drive a generic process load. You get a display that shows the tank temperature and the present setpoint. It can be switched to show the command to the heater, for use in troubleshooting. The controller, in standard form, contains two adjustable alarms to shut down runaway heating and alarm remotely. Optionally, it accepts a remote setpoint and has a repeater on the tank temperature for remote indication. Besides being able to command the heater in a range of 0 – 100%, the TIC is programmable for “how hard” it tries to meet the setpoint. The programmable proportional, integral and differential (PID) parameters will be discussed later.

This course will not address types of heaters and packaged heater controls, beyond noting that almost all include a separate over-temp shutdown. Fired heaters must have ignition controls certified by a recognized third party testing agency, as IRI.

A very, very common example is pressure control. The following arrangement was recently installed in a chemicals building where some of the mixers were malfunctioning because city water dropped below 40 psi.

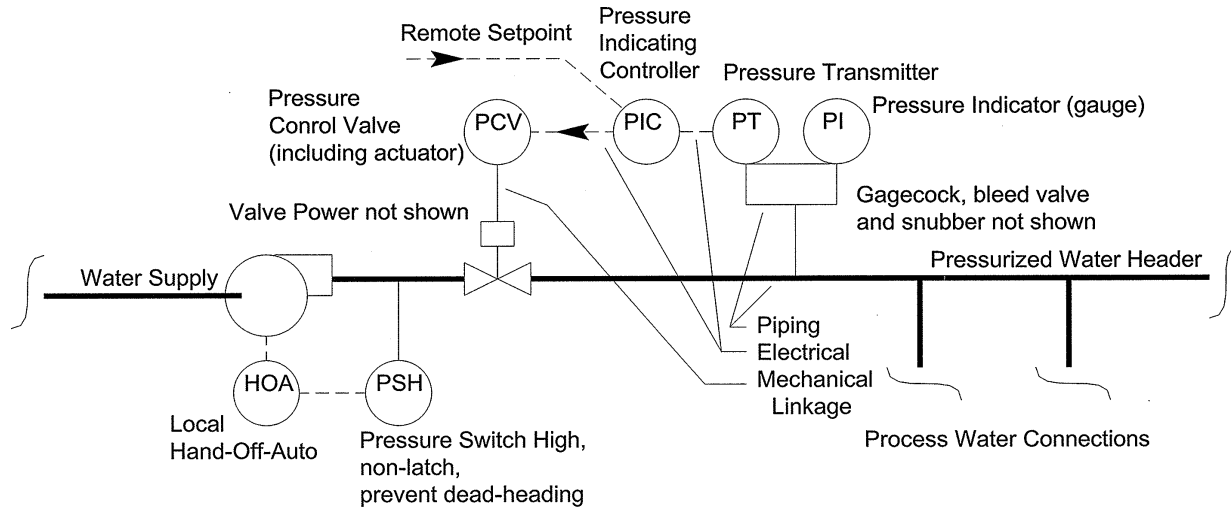

Process and Instrumentation Diagram (P&ID)

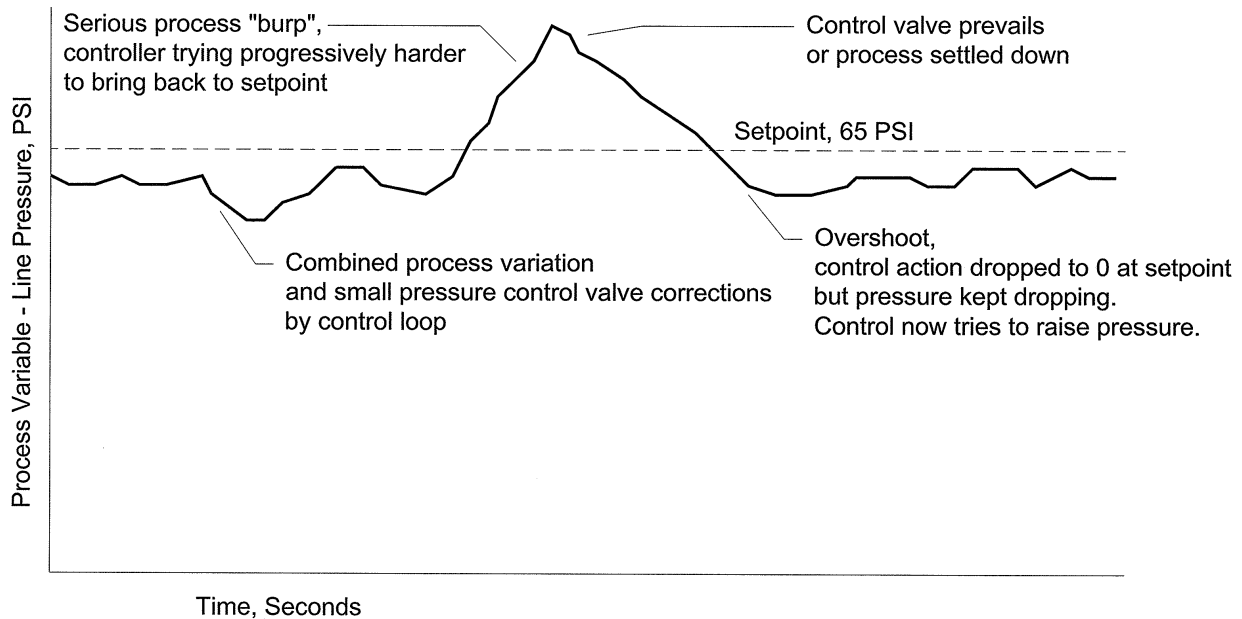

Annotated Process Trend Chart (Recorded Signal from Pressure Transmitter)

Control schemes not discussed, advanced control concepts, cascade control, multi-loop control, predictive control and formal hazard assessment - Some of the best controls engineers have a Ph.D. in instrumentation. Others have B.S. in instrumentation or chemical engineering, with 10 or more years experience designing and starting up control systems. These backgrounds permit them to address very complex control problems using

a number of well-defined advanced control schemes. There are local controls vendors in all parts of the United States who know who the local experts are and can help you find them.

An early statement in this course was that intimate understanding of the process is necessary in order to properly apply automatic controls. It is important to do no harm in the application of automatic controls. As processes have become more integrated and more complex, a formal scheme of hazard analysis has been developed and is required by OSHA. If your process contains life-safety hazards or could possibly produce life-safety hazards, you are advised to investigate formal hazard analysis. There are links at the end of the course.

Sensors - Discrete sensors, like the float switch, have an off-on output when the process value passes the setpoint. Proportional sensors, like a level sensor, have a continuous output, or 0-100% with built-in alarms for open circuit or short circuit on the wiring. An *alarm relay* has been available for a long time to take the proportional signal and switch off-on outputs at adjustable setpoints. The proportional is not affected and can be used for control or indication. Today, high-end level sensors have both the 0-100% proportional output and adjustable setpoints. There are also special devices that look like proportional sensors but act like discrete sensors.

An example of the proportional/discrete sensor is the non-invasive level switch. One form is ultrasonic. It is strapped on the tank and operates an off-on switch when the level inside the tank passes the application point. A more complicated form uses a low-power nuclear source on one side of the tank and a detector at a different level on the other side of the tank. Depending upon the fill of the tank, more or less radiation reaches the detector and three off-on switches can report different fill levels. Both of these methods work well with highly agitated liquids, frothy liquids and extremely nasty liquids you really don't want to be in contact with.

Non-invasive flow switches and flow transmitters are also available. Some respected process designers doubt their reliability and continued accuracy and will not specify them. Cost is in the \$1000's. See magnetic meters and ultrasonic meters in the links at the end of the course.

One caution: Active sensors usually require an external power source, 120 VAC or 24 VDC. The power is not a problem, providing the extra conductors may be, if not anticipated. Spare conductors or spare shielded twisted pairs (STP) are a good idea.

This course does not describe every sensor available and all of the variations. Please review the symbol legends in the Appendix for types and browse the links on the InterNet for manufacturer's literature. Local manufacturers' representatives are very helpful for projects anticipating near-term purchases, but they avoid new technologies not supported by their principal firms. [Technologies like ultrasonic and radiation are proprietary and limited by patents.]

Actuators - Actuators are the devices which most directly affect the process to bring about the desired control change. Pumps, pump motors, motor starters/VFD. Our definition of actuator is the motor starter or VFD, which receives the command from the manual or automatic controls.

Valves and valve actuators are defined separately in the popular language. The valve blocks or permits flow. The actuator swings the valve to change its state. A solenoid actuator is off-on. A proportional actuator permits 0-100% selection.

As with sensors, a wide range of actuator types are identified by the symbols in the legends located in the Appendix. Details of each are not addressed here.

Permissive control logic - It is bad, sometimes destructive, to start a pump into a blocked discharge. The start-up procedure should include the human operator checking the valve positions before starting the pump. This can be done by end-of-travel limit switches on the valve actuator and the EOT limit switches wired into the control circuit.

A balance is necessary to assure occasional human inspection, but permitting cyclic operation without continuous human participation. Please recognize that EOT limit switches slip out of adjustment. Experience has been more in the direction of incorrectly blocking startup than incorrectly permitting startup. Still, EOT limit switches can add to the problems, especially if poorly documented and awkwardly located.

It is bad to start pumping into an already full tank. A limit switch on the destination tank can be wired as a stop on the pump, even though it is not directly part of the discrete pump down control loop.

Control alarms - In closed loop control, the process variable changes; the sensor identifies the change; the logic determines that an off-setpoint condition exists and issues a command; the actuator adjusts the process variable; the process variable returns to the setpoint value; the logic goes back to sleep. It is almost universal to include a time-based alarm between the command and the sensor input. If no reaction occurs within a reasonable period, perhaps 30-seconds, a control failure alarm is issued.

For example, the logic commands an HVAC fan to start. The controller usually includes a sail switch in the air flow to prove fan start. An alarm is issued if the sail switch does not actuate within 30-seconds. There are sail switches for water flow also. Be warned that sail switches are high maintenance items. They should be located for easy removal and replacement.

By the way, an auxiliary contact on the motor starter is a very poor proof of fan start or valve swing. Any interruption between the starter and the actuator produces a positive proof but no process control. A current flow switch (integral current transformer, \$25) is a good proof, without entering the fluid stream. A static pressure sensor (0-100%, \$150), has a tap to the fluid line but lasts better than a sail switch and provides a very sensitive indicator to full system operation.

Single-loop controllers - A dedicated single-loop controller has a limited range of application. For example, a \$150 single-loop temperature controller usually has only temperature sensor inputs - thermocouple, RTD and, possibly, 4-20mA from a temperature transmitter. [Caution, there are very many kinds of thermocouples and many

kinds of RTD's, but only two kinds of 4-20mA, upscale on temperature rising and downscale on temperature rising.]

The single-loop temperature controller may have only time-proportional off-on as the output. The output is turned on for a longer time when more heat is needed to achieve the temperature setpoint. Alternatively, it may have a phase delay output, to turn on an external solid-state relay earlier or later each cycle to control the heat value being added to the process. It may have a 4-20mA output for connection to a powerful heater control or main gas valve.

The single-loop temperature controller will have the process variable displayed in degrees-C or degrees-F. The adjustable setpoint will be in degrees-C or degrees-F.

The single-loop temperature controller will almost certainly have a high-temp alarm. This is a common system malfunction and can be catastrophic. It is not unusual for the designer - to include a totally stand-alone high-temp shutdown switch, use the controller high-temp alarm and have an internal high-temp shutdown in the heater power unit.

Because of the flexibility of computer software, a \$500 single-loop universal controller is possible. The input is selectable from multiple thermocouple and RTD types and the 4-20mA process input is scalable in range and offset, sometimes with three-point contour adjustment. [This discussion does not include 2-10VDC or 0-10VDC. Both have specialized application and can be very useful.]

The single-loop universal controller will have scalable 4-20mA output and many adjustable alarms. It will have displays for process value, setpoint and command output selectable in mA, %, and scalable process units.

At no extra charge, the single-loop universal controller will have an analog signal repeater and a simple serial data communications channel, often a proprietary RS-232 or RS-485, but often open-architecture ModBus or TCP/IP.

Use of the data communications channel is very much a part of this course and will be addressed in detail later.

Tuning proportional controllers - The discussion of loop controllers rapidly focuses on the numerical difference between the measured process variable and the setpoint. This is the process error which must be corrected by the actuator. If the available actuator range is 0-100%, how much process error gets all 100% corrective action? How much process error gets only 1% corrective action? The answer is the gain setting on the controller.

The loop controller acts just like you would if you were watching a temperature gauge and had a heater control to adjust. Your boss says, "Hit it hard. Turn it full on to get it up to temperature, then turn it completely off when it hits setpoint. It will overshoot, but that's OK. When the temp drops back below setpoint, hit it hard again." This is the result of setting the controller gain high. It hits it hard. The controller swings the actuator from full-off to full-on and back. It isn't very proportional, but it is control, and depending upon the time constants of the process, it may work well.

Given the same manual situation, but your instructions are, "Be careful with this one. The stuff is very sensitive to over-temp. Don't hit it too hard. It will be slow to come up to

temp, but we don't want any overshoot." This example comes closer to the 1% example, except that we are working with net process error, so beginning at room temperature, we will have maximum error and apply the maximum heating permitted by the gain setting. As we approach setpoint, the error gets smaller and the applied correction gets smaller.

In the low-gain case, you might think that $\text{Setpoint} - \text{Room temp} = \text{maximum process error} = 100\%$. Output is 0-100%. So, gain setting in percent is easy. Use 1.0.

No so. As mentioned earlier 65% output on one actuator has different effect than 65% on another. In the heater example, 65% command to a 1KW heater has very different effect than the same 65% to a 10KW heater. There are several numeric and graphic methods to tune the controller, but the result is that you try different values and the one which makes you (and your boss) happy is the correct value. WRITE IT DOWN. [It will change if the process changes or you change out the actuator to a different type.]

We will now enter into one of those not-discussed-here discussions. Loop controllers come from the factory with three tuning parameters, proportional, integral and derivative. Proportional is the gain, just addressed. Integral is an internal gain correction. With lots of integral action, the controller get impatient when the gain setting and resulting output don't have much effect. Proportional boosts the gain. When the output starts working, proportional drops the gain back to the preset value. Sounds like a good idea, and it is a good idea. Except, integral always has the effect of increasing gain. Therefore, if you are going to use integral, you should back off the proportional somewhat. The second problem is that too much integral sometimes gets confused. This, too, can be corrected, but the tuning is becoming complicated - gain, corrected gain, integral, but not too much integral, correction for confused integral. Good idea, but please go slow.

Derivative is worse. The goal is to help the controller respond to sudden, large process value swings. For instance, another boiler is brought on line and delivers 70-F water into the 200-F process feed. Give the controller some derivative and it will try-really-hard to correct the sudden, large process error. Again, sounds like a good idea. This course recommends not touching the derivative adjustment unless you have supreme confidence in your understanding of the process and that a sudden, big swing in actuator correction is acceptable (not so on hot water systems, boilers and piping).

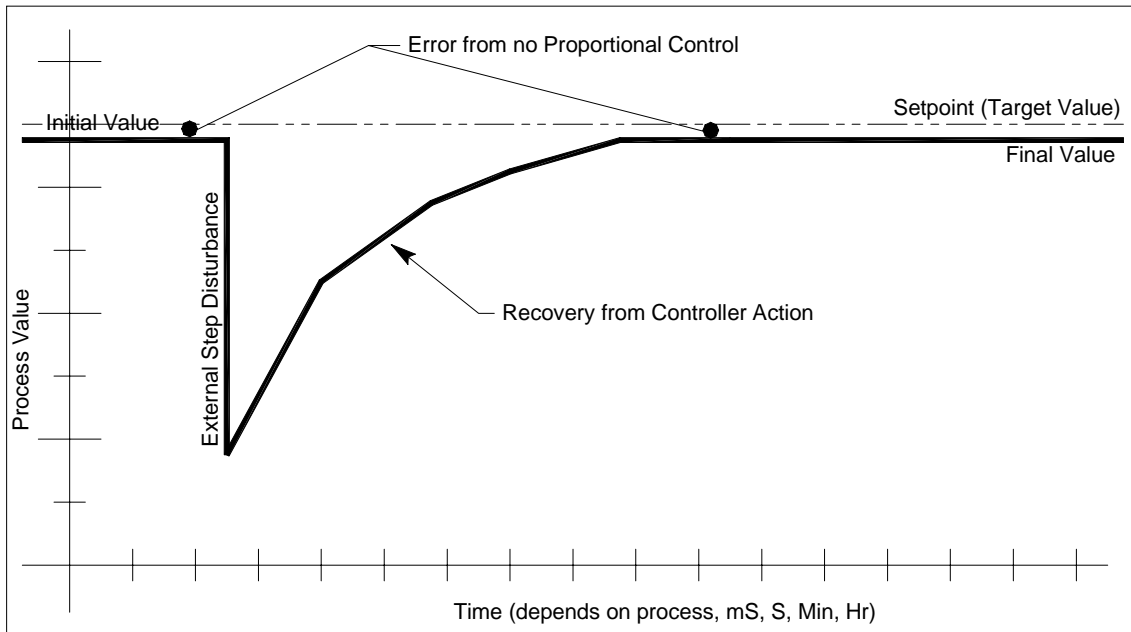

Process Trend Chart - Good Tuning

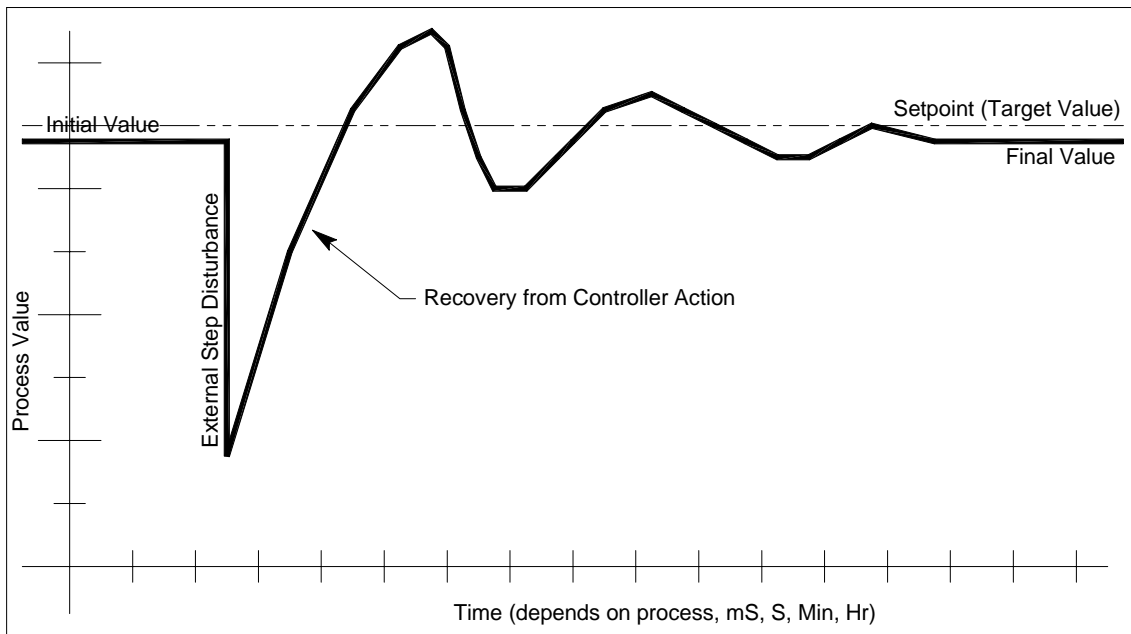

Process Trend Chart - Good Tuning, High Gain

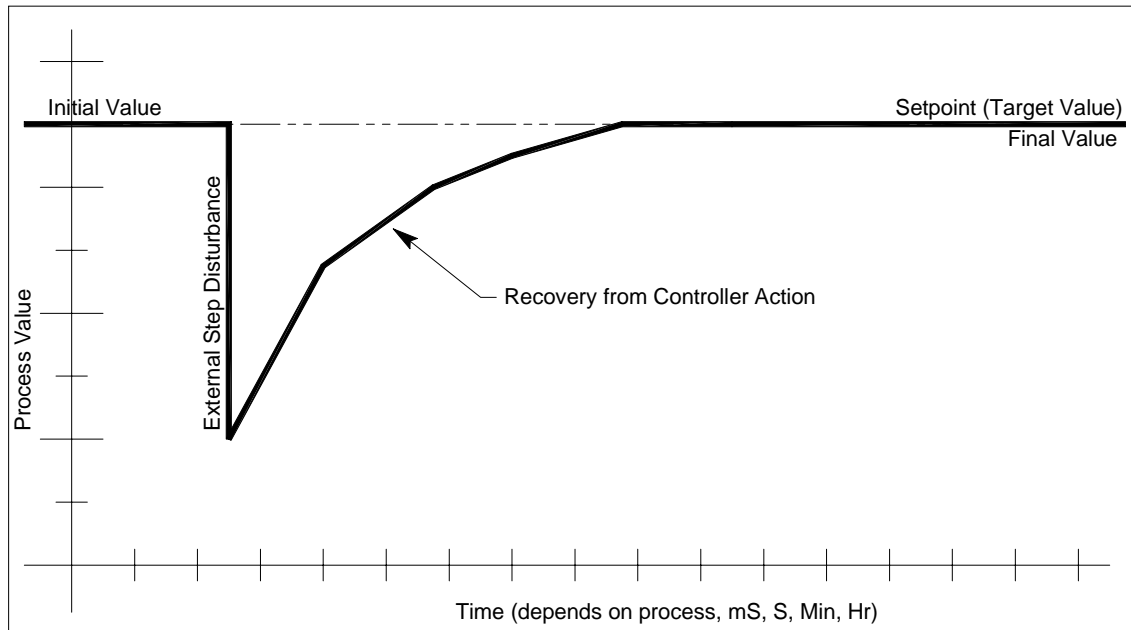

Process Trend Chart - Good Tuning w/ Proportional

Centralized controllers (DCS), not - A question that comes with every computer application is, "Where to put the machine?". In office applications, it was once thought that economy resulted from a large staff of high-paid staff who tended the machines and exchanged data card decks with users at a window. In the office application, the machine evolved to a file-cabinet sized box which sat next to someone's desk, in the office, and was visited occasionally by the high-paid staff over the phone, or, very rarely, in person. Today, many office applications have returned to a protected roomful of smaller machines, coupled with powerful desktops for every worker. Yes, school custodians order toilet paper from the desktop that monitors the school HVAC system and has a LAN connection to the school Business Manager.

At the time of the large computer rooms, chemical plants and oil refineries were operated from large control rooms. There were three or four sections of the control rooms. The large front part had comfortable chairs and desks, with dedicated control consoles of lights and buttons. The back wall was filled with chart recorders and large-case, then small-case single-loop controllers. Behind the control wall were the mechanical and electrical parts of the single-loop controllers and the wiring racks of incoming and outgoing (pneumatic tubes) electronic cables. Many control rooms had an isolated roomful of batteries, with a charger and inverter, to permit some control when utility power was interrupted.

Manufacturing plants did not have hardware control rooms. They had offices with clipboards of current information and full-wall scheduling boards and blackboards to keep track of production plans, status and equipment status. There were control panels for individual machine out in the plant, but information was gathered by shift reports and tags attached to pallets of parts moving around the plant.

Controls manufacturers adapted the large computers to the control of chemical plants and oil refineries. The old control wall was ripped out, a few critical or government-required

recorders were installed, a mini-computer was installed in the technical area and dumb terminal screens and keyboards were built into super-modern custom desks. Area control rooms were usually left intact, with the old chart recorders still in place and the single loop controllers on the control wall. On the technical side of the control wall, cables were spliced together to run the signals to the computerized main control room. [Not really - they pulled out the old cables and ran new cables from the field sensors and actuators all the way to the computerized main control room. But, this took time and was not part of the initial installation.]

For reasons never obvious, this evolution to central control was called Distributed Control. A key term, always mentioned at this part of the historical narrative, is VAX. VAX was a mini-computer created and sold by Digital Equipment (no part of HP/Compact) which did not require water cooling and was much more forgiving of real-world influences than anything from IBM. Honeywell had a competitive unit, which also sold well. VAX stands for virtual addressing, a powerful programming scheme which was reinvented by Motorola for microprocessors and then adopted by Intel.

Besides controlling the chemical plant, the VAX could talk to the front office and the corporate office. Suddenly the high-level decision makers had real-time summary data. [There was a theory that management and corporate technical persons also had access to individual loop data. In 20 years of watching, I never saw this used.]

The computer control worked well. Manpower at the refineries was reduced, yield increased and management felt they were making better decisions because they had better data. The manufacturing watched this and the computer vendors started selling plant computers to manufacturing concerns for local data gathering and reporting to headquarters.

In an apparently independent development, American manufacturers took a sudden interest in proactive quality control and inventory control - just-in-time deliveries - no intermediate storage or safety stock. Computers permitted one-week, even one-month production planning and materials ordering. Data entry on the receiving dock supported real-time inventory numbers and immediate panic and phone calls for late delivery. Large plants put a large computer and data entry stations for supervisors throughout the plant. Very slowly, direct connections to machines were made and automatic parts tracking was installed. This is successful in large plants, but still at the introductory stage for small plants.

Again, the large central computer was called distributed control.

Dedicated control subsystems - You buy an inline electric heater for your HVAC system; you get a set of factory-supplied controls. You buy a robotic welder; it comes with a control panel, ready to plug in and train for your job. You buy an emergency generator; it comes with a control panel and a remote annunciator. You buy a plastic extruder; it comes with a control panel. You buy a variable speed fan or pump; it comes with the motor, VFD controller and a chicklet keyboard and alphanumeric display.

The common element of these varied packaged systems is that they all have supplied automatic controls. There are a range of published standards which can be enforced through the purchase specification, but most manufacturers have evolved to very similar off-the-shelf control packages. They all have a power disconnect or require the installer to supply an incoming power disconnect. They all have a clear indicator that they are turned on, or enabled. Many have a run-time meter or a master control relay which can be

connected to a run-time meter. Many have a contact for a remote alarm bell or light for a malfunction and another contact for remote bell or light to indicate self-protective shutdown. Some accept remote start and stop. Some report individual alarm and fault problems. Some have a proprietary form of serial communications for reporting to an optional remote console.

The next section discusses design and fabrication of automatic controls to retrofit an existing system or machine. After that is a discussion of standard monitoring for factory-supplied control or locally fabricated controls.

Installation of automatic controls - First, consider safety and liability. A formal hazard analysis lists what can be normally expected to go wrong and what is not expected to go wrong, but might. Each event is followed to its expected consequences if not interrupted. The most likely malfunctions and those with the most catastrophic consequences must be addressed. Some judgment is applied in choosing events not to be addressed. The power of the method, apart from directing quality thinking to the problem, is that the lists are documented for review by supervisors, insurance representatives and safety departments. There are federal laws requiring such reviews and specifying the method, but they are rarely enforced.

For this course, a set of automatic controls must always have manual shutdown or emergency stop. The automatic controls must be configured for safe shutdown in the event of a failure. In some critical applications, it is necessary to have a manual run override. (For instance, a wastewater stream cannot be interrupted because the controls fail or a pump is out of service. Valves must have manual operators or provision must be made for overflow to a planned holding area.)

Manual shutdown can be the main power disconnect switch. If this is the plan, then check to make sure that no components require a shutdown sequence which will be bypassed by a power interruption.

Automatic shutdown is easily implemented by use of a latch circuit, shown below:

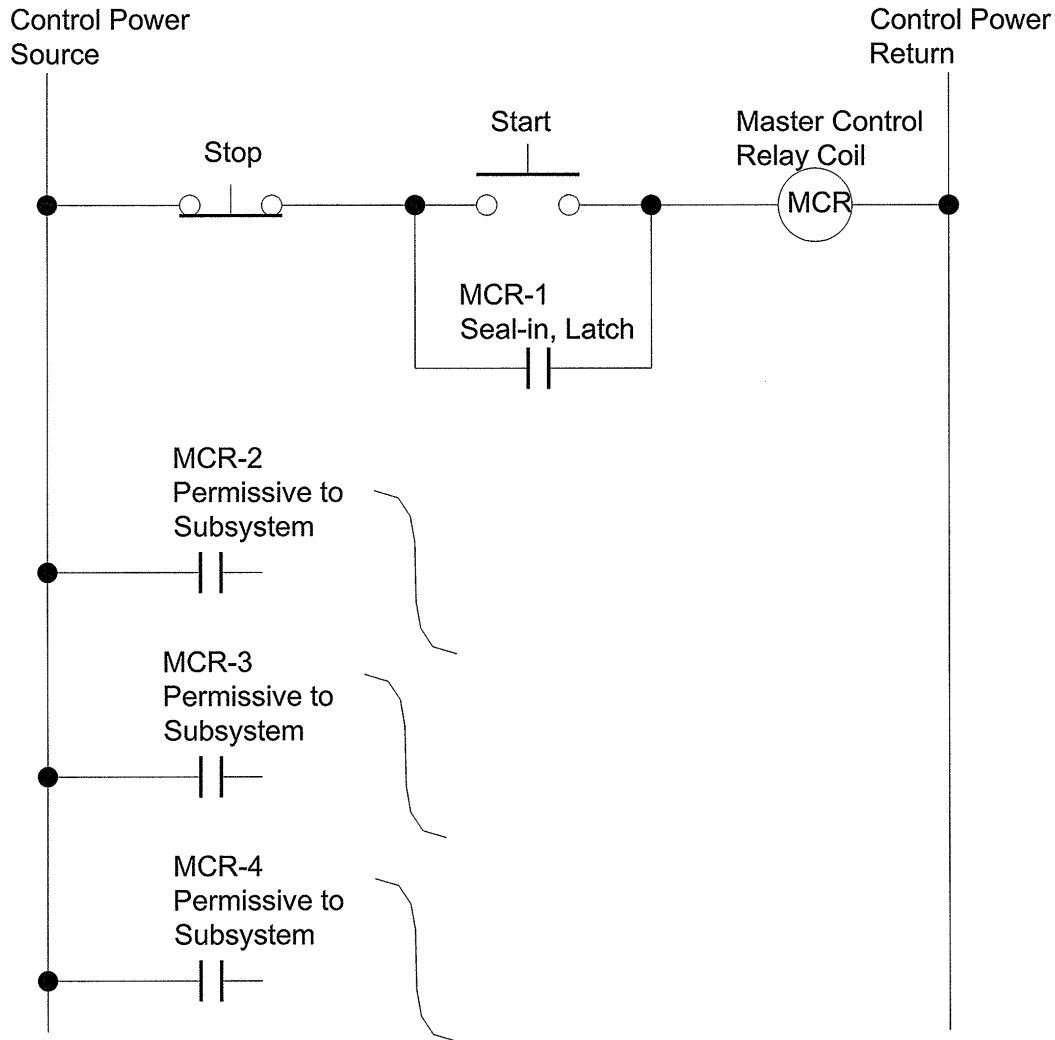

Master Control Relay for Safety

Your author uses this circuit constantly when installing alarms, as a flow switch on an emergency shower/eyewash. When the flow switch closes (the start button here) the Master Control Relay pulls in and latches the initiating contact. The master control relay continues to hold all contacts closed until the reset (stop button here) is pressed.

A four-pole double-throw relay is a stock item at all electrical supply houses and a general-purpose type is satisfactory except in an explosive or corrosive atmosphere. Most panel builders prefer a plug-in base permanently mounted to the control box sub-plate and a keeper spring over the plug-in relay - whether vibration is present or not.

A list of warnings go along with this circuit.

1) Use an electro-mechanical relay. People who love computers have many reasons to include the MCR function in the software. Avoid this. All safety standards presently require an electromechanical relay. Problems with relays tend to be obvious.

- 2) A control power transformer with high-side and low-side fuses is recommended. If you pull control power off a lighting panel, it goes off when someone turns off the wrong lighting breaker. From the machine power, controls are on when the machine is on and off when the machine is off.
- 3) Follow the order of circuit elements as shown. Hot supply conductor - stop button - start button with latch - relay coil - grounded return conductor. This has been standard for over 50 years and anything else violates regulations.
- 4) Use heavy duty oil tight pushbuttons, preferably NEMA 4X (corrosion proof). Cost is about \$10 each, but they are indestructible. 22mm or 30mm, your choice. Use a NEMA 4 or 4X box with sub-plate. Cost is upwards of \$20. There is controversy about steel vs indestructible plastic. Again, your choice.
- 5) Box should be at least 2x the size you first think. You need space for incoming conduits and wiring gutter space around the edge.

In this section, we are building a control box. In the next section, we are retrofitting an existing set of controls for central monitoring. It is reasonable to add the central monitoring to the control we are building.

Below is the master control relay just introduced. Added at this point are the local elapsed time hour-meter and the relay for remote status reporting. The hour-meter costs \$10-40, depending upon where you buy it. It is a very powerful means to identify machine malfunction. Put it on a pump starter and have the operator record the value once a month. When a leak occurs, the pump will run more than expected and you know to look for the leak. Put one on each boiler and you have permanent record of the operator rotating the units. Same for a duplex pump controller. \$20 and you know for sure. I put them on electric blow down valves on boilers so I can see what the operator is doing each month.

The status relay appears arbitrary. Why not just take an auxiliary contact from the MCR? Why not just run a 120V lead from one of the MCR contacts back to the monitoring point? Because it is unsafe and makes it harder for the technician who will someday troubleshoot problems on the controls. A separate monitoring relay assures that the monitoring is not messing up the machine operation. The dry contacts reduce the hazard to the technicians, though the remote power source should be labeled. The monitoring cables and equipment cannot blow the machine control fuse.

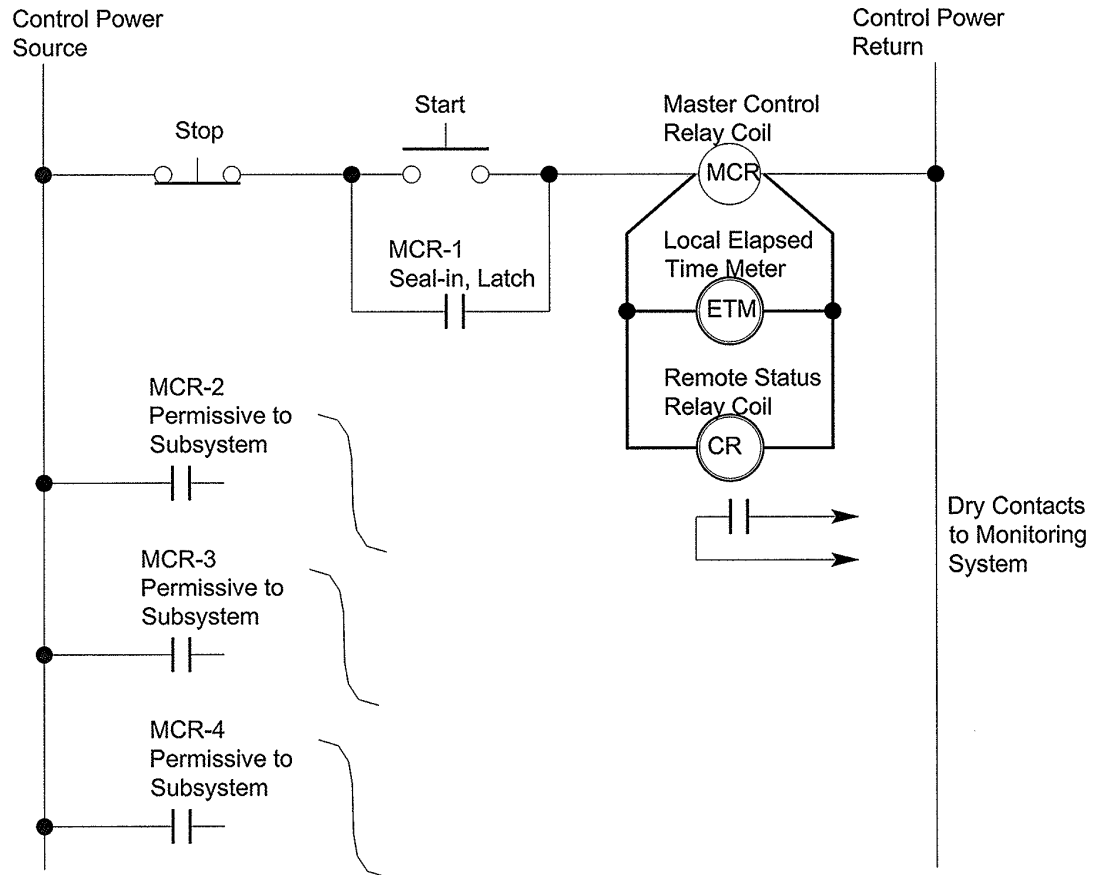

Elapsed Time Meter and Remote Status

Installation of standard machine monitoring - Close examination of industrial processes reveals that all are alike. There is a process variable, units per minute, pounds per square inch, discharge temperature, seconds per minute weld time or keystrokes per minute data entry.

There is a set point, the desired value. In the case of automatic machines or automatic processes, the set point is an adjustment. For manual tasks like checkout clerk or welder, it is part of the process documentation, but not remotely adjustable.

There is a command to run and a status that the process is running. An objection often arises at this point in the discussion. Why not save money and just monitor the run status, not the process variable value. The generic response is that 50% operating counts as running, but 80 or 90% is desired. The discrete value of run status tells you that you have an immediate problem. The analog process value identifies long term and shift-to-shift problems. There is a well developed science of analyzing process trend charts, discussed in detail in the PDH Online course on Quality Assurance. The following is a quality control chart of the pressure loop discussed previously.

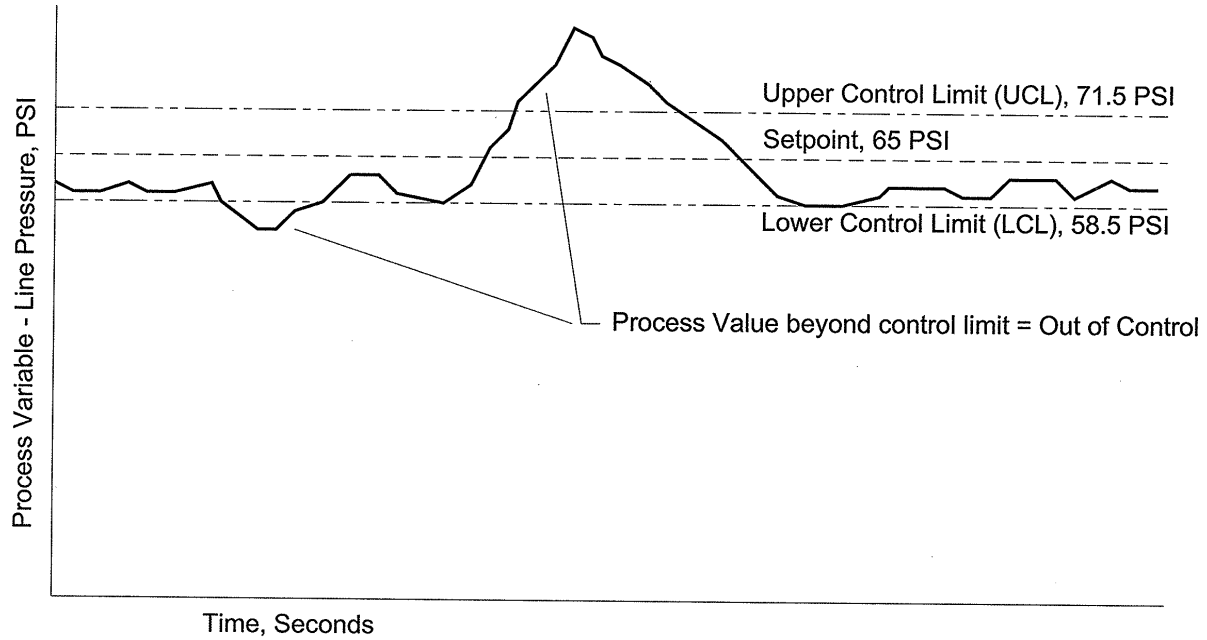

Annotated Process Quality Chart (control limits determined by software)

The following is the field box used to add central monitoring to an existing control system. It is a bad idea to take over a corner of the existing control cabinet. Whenever there are maintenance needs on the machine, the first suspect is the addition and there is a good chance the new stuff will be ripped out to help get the machine back on line in a hurry. Put it in an external NEMA 4X box and nipple it into the existing control box. Train the cables nicely so it looks right and it will survive longer.

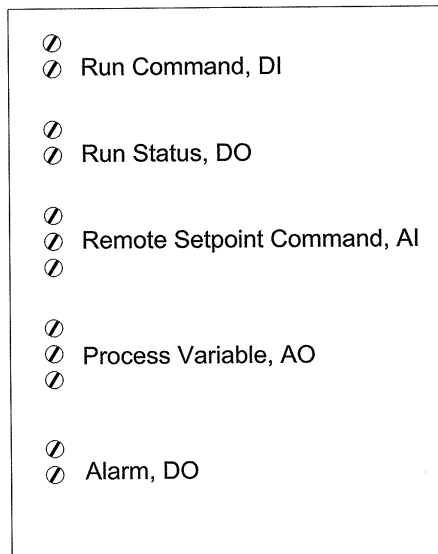

Standard Remote Monitoring

The Run Command, DI, is a command issued by the central console and accepted as a discrete input by the existing controls. Two wires, usually 120VAC. Put it in, even if central control is not in the present scope.

Run Status, DO, is the report from the machine control back to the monitor that it has power and is on-line. Again, two wires, usually 120VAC.

Remote Setpoint Command, AI, is the twisted-shielded pair (TSP) from the console to the local controls. As before, include even if not part of the present scope. The shield connection for the TSP will be defined by the plant. Most systems connect the shield to ground only at the central monitoring point, but splice it through any intermediate blocks so that it is continuous all the way out to the machine. At the machine, it can be cut off and the stub covered with heat-shrink tubing, or connected to an unconnected terminal. Do not connect the shield to frame ground unless you are very sure what you are doing. It is bad to get 480V fault currents running through instrumentation shields.

Process Variable, AO, reports the analog value of the process variable being controlled. Most single-loop controllers include a PV repeater output for this purpose (or for a chart recorder or logger). If not included in the controller, a repeater module can be purchased for about \$100. Do not send the actual PV signal across the plant. Isolate the outgoing signal from the actual controls.

Alarm, DO, reports any alarms from the machine back to the monitor. There is an opinion that warnings should be reported separately from shutdown alarms. Your author believes that any abnormality should be reason to dispatch a service person to the machine. The Run Status signal identifies if the machine is down or running.

Installation of standard monitoring marshalling panel - In the old days, all of the monitoring and control cables in an area of the plant were run to a really big box with lots and lots of terminal strips. This was a marshalling panel. Then, all of those circuits, along with 20% additional spare, were run to another really big box at the area control room. After that, they spread out to the individual chart recorders, alarm indicating lights and single loop controllers.

This is not done today. The terminations are the weakest part of the installation. Avoiding two really big boxes of terminations saves a lot of money and improves reliability. The idea is wonderful, however, and it is fun to say marshalling panel.

The 2003 method of bringing hundreds of circuits from the field to a central location is remote input/output, a data cable and a spare data cable. Remote i/o has become a commodity. Many reliable manufacturers sell a DIN rail with input blocks and output blocks and a power supply and a space for the communications module of your choice. (See the links for remote i/o at the end of the course narrative.) The old marshalling panel is replaced by a really big box with active terminals, some data gear, a power connection and a tiny, low-voltage data cable to the control room. Illustrative raphic follows:

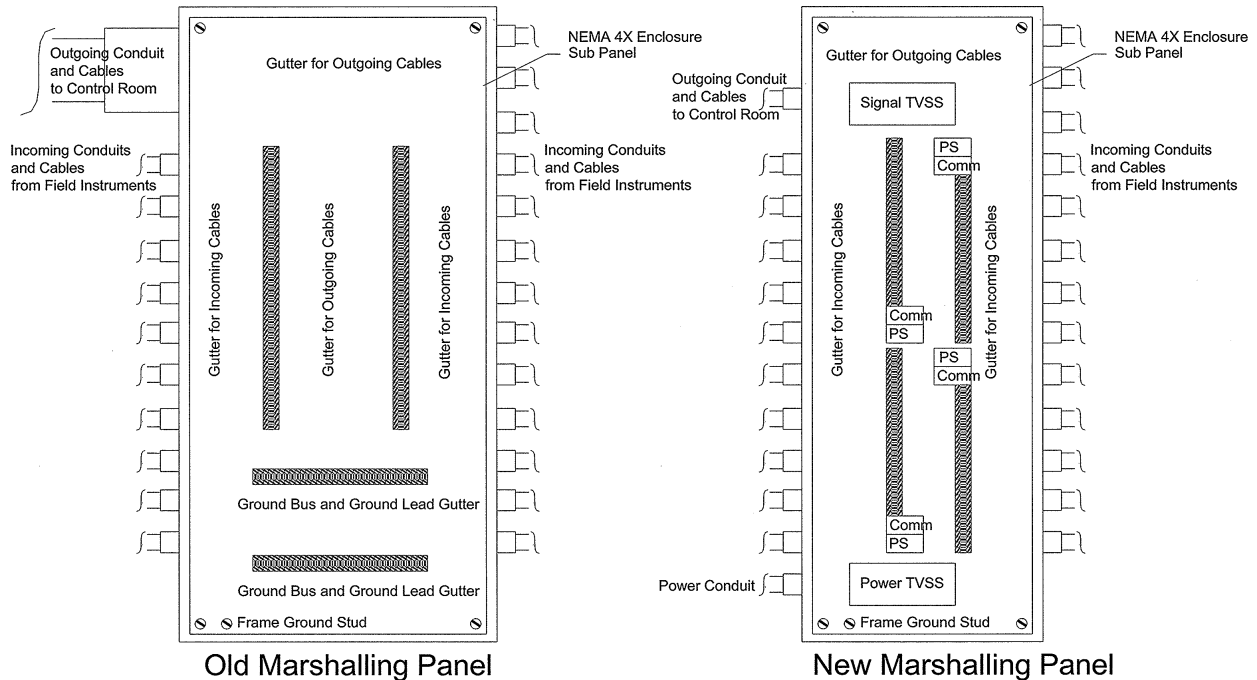

The vendors keep telling me that a "brick" PLC with data communications and all those i/o terminals. You can pick up the PID controllers inside the PLC and provide many, many single loop controls with a single PLC and a low cost graphic user interface (touch screen). Every time I do the numbers, though, it is 2x more economical to use panel-mount single loop controllers and remote i/o. Also, most technicians can configure a single loop controller. There are technicians who can troubleshoot PLC programs, but they are different technicians.

Installation of data communications cables - ModBus. For us, today, ModBus means 9600 BPS multi-drop RS-485 wiring with ModBus RTU communications protocol. RS-485 is a fairly old wiring method, with 4000-ft maximum distance. Being old, there are a wealth of competitive interface products available and extensive technical support available. The basic form is jacketed two conductors plus shield (Belden 9463, 2-#20 stranded, foil polyester shield). The shield can be dropped and the communications work very well in industrial environments as jacketed two conductors plus ground (West Penn 232, 3-#20 stranded, jacketed). (No one will tell you that the unshielded version works.) Instructions for installation of RS-485 vary extensively. Sometimes the shield must be terminated at both ends, sometimes one end, cut carried through the run. Follow the instructions for the ModBus remote i/o you select, so that the tech support people there will talk to you. Below is a reasonable connection diagram:

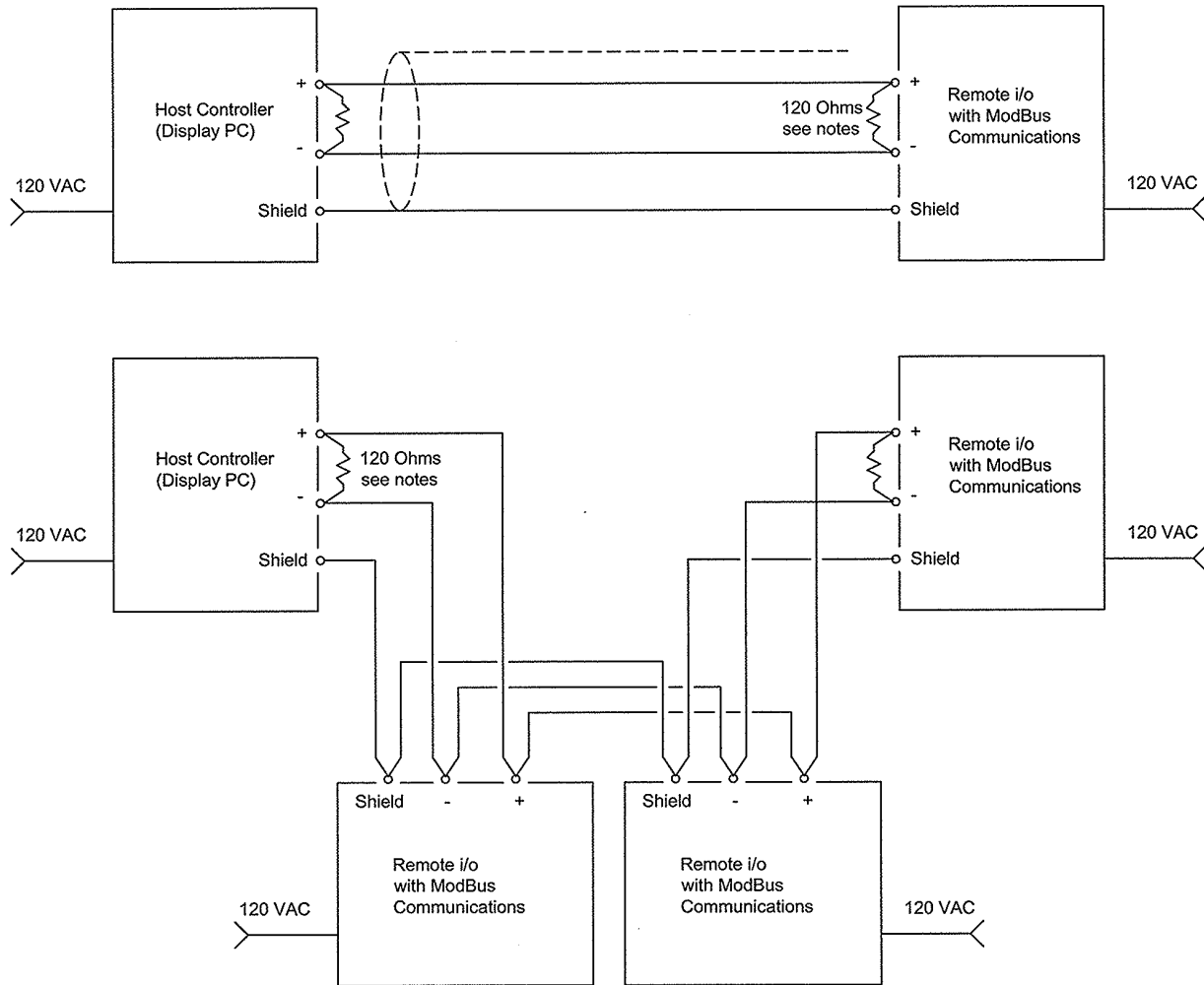

ModBus / RS-485 Field Wiring

- Notes:
1. For long-distance communication, or if noise from an external source interferes with the signal, install 120-ohm, 1/2-watt resistors across terminals of both end devices.
 2. Terminating resistor may be internal to device, with switch to USE or NOT USE.
 3. Multi-port PCI cards for the display workstation are available. Check with software vendor for support before purchasing.

The 4,000-ft limit for ModBus / RS-485 has many work-arounds for campus installations or large integrated facilities. The easiest is the repeater. For ~\$150, it isolates the host side of the circuit from the field side of the circuit and regenerates the signal for another 4,000-ft run. Johnson Controls uses RS-485 for their MetaSys N2 bus and can provide or supervise field installation and start-up.

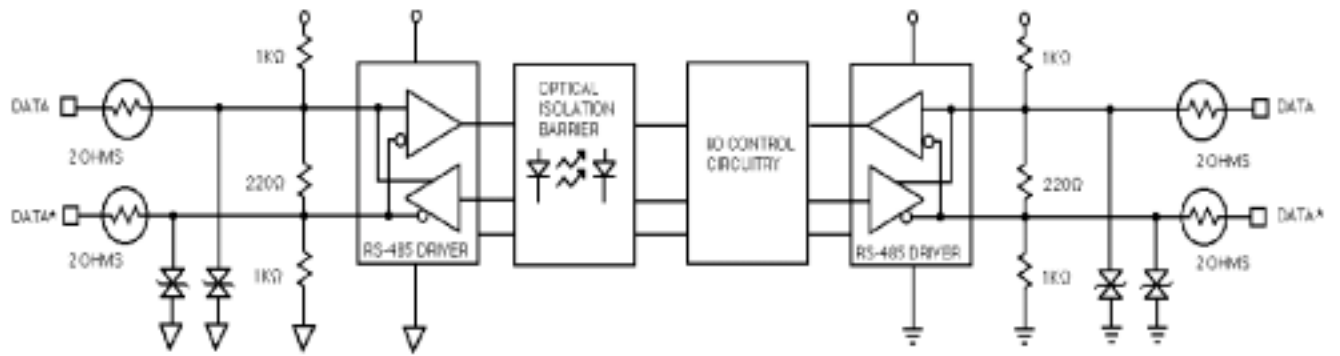

This is the DataForth SCM9B-D192. It can be used as follows:

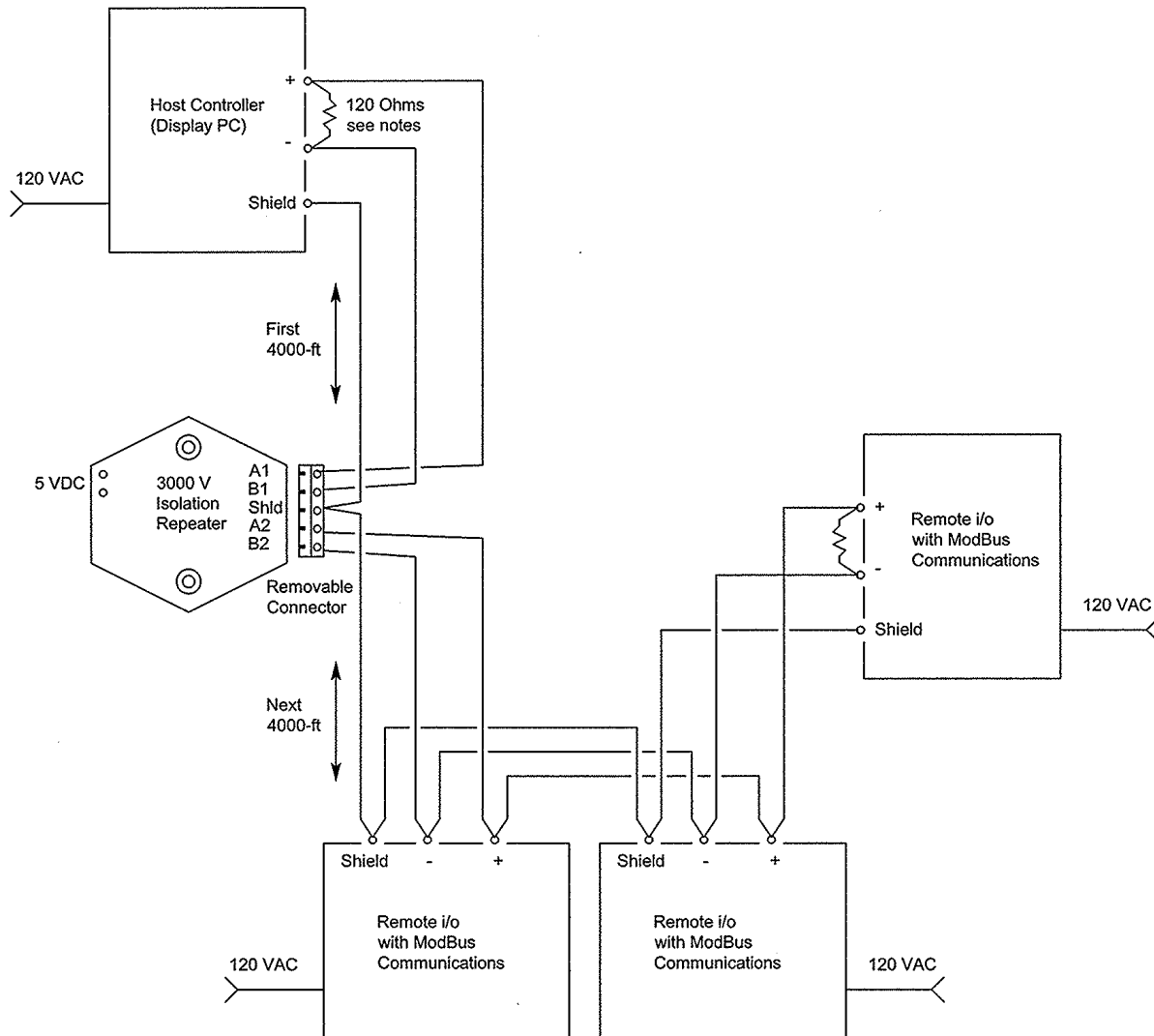

ModBus / RS-485 Field Wiring with Repeater

- Notes:
1. For long-distance communication, or if noise from an external source interferes with the signal, install 120-ohm, 1/2-watt resistors across terminals of both end devices.
 2. Terminating resistor may be internal to device, with switch to USE or NOT USE.
 3. Multi-port PCI cards for the display workstation are available. Check with software vendor for support before purchasing.

A second work-around for distance is translation to fiber optic. Individual modules cost ~\$100 and support very long distances without modifying the ModBus data packets.

Another work-around, not recommended here, is the gateway. This \$500 - \$10,000 device decodes the ModBus data packet and re-encodes it in another protocol, such as TCP/IP. The results are very satisfactory, but starting with a TCP/IP power meter is usually no cost increment over ModBus.

Installation of data communications cables - TCP/IP communication - For us, today, TCP/IP means unshielded 4-pair Cat 5 copper unshielded twisted-pair (UTP) cable with a 300-ft maximum distance and a \$20 10-megabit hub to attach more devices. This form of local area network (LAN) wiring is extremely popular with a wealth of competitive interface products available and extensive technical support available.

There is much confusion on what TCP/IP means and how local area networks work. The underlying principle is that a system is installed which handles information packets by reading the destination and size and paying no attention to the contents. You type <Alt> F S and MicroSoft WORD establishes a path to your server and saves your word processing, then closes the path. It may go through, hubs, routers, data switches, a T1 link and a satellite link. Similarly MicroSoft EXCEL can create a path to each remote i/o block, download data and close the path.

The 300-ft limit appears to be onerous, but that only means that the existing Information Technology (IT) group must have a data port within that radius. There is always the option of buying a ~\$100 converter and running your own fiber optic back to the display workstation. However, installed LAN's are almost universal and can be shared for low bandwidth meter communications. The alternative of a dedicated fiber optic run is very economical for a two-strand cable, but considerably more expensive for the a 12-strand cable which will support the long-term IT plan.

Cat 5 cable can be run by in-house staff or a contractor who has a continuing relationship with the firm. Cost is amazingly low. I consistently had twelve drops in a six-story building installed and terminated for \$800 per building (multiple very similar buildings). Below is a reasonable connection diagram:

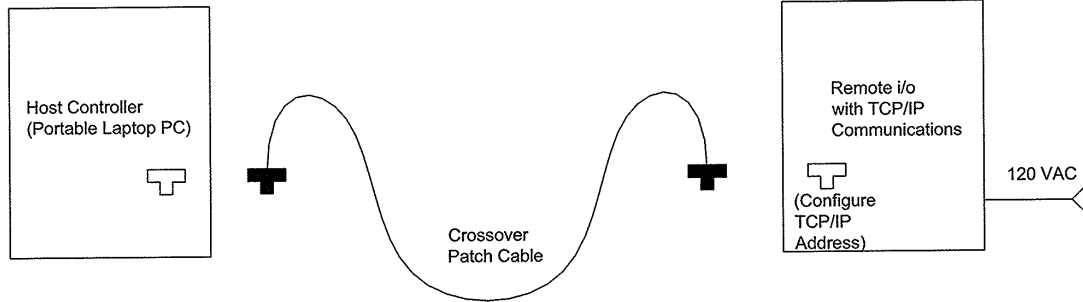

TCP/IP download Field Wiring

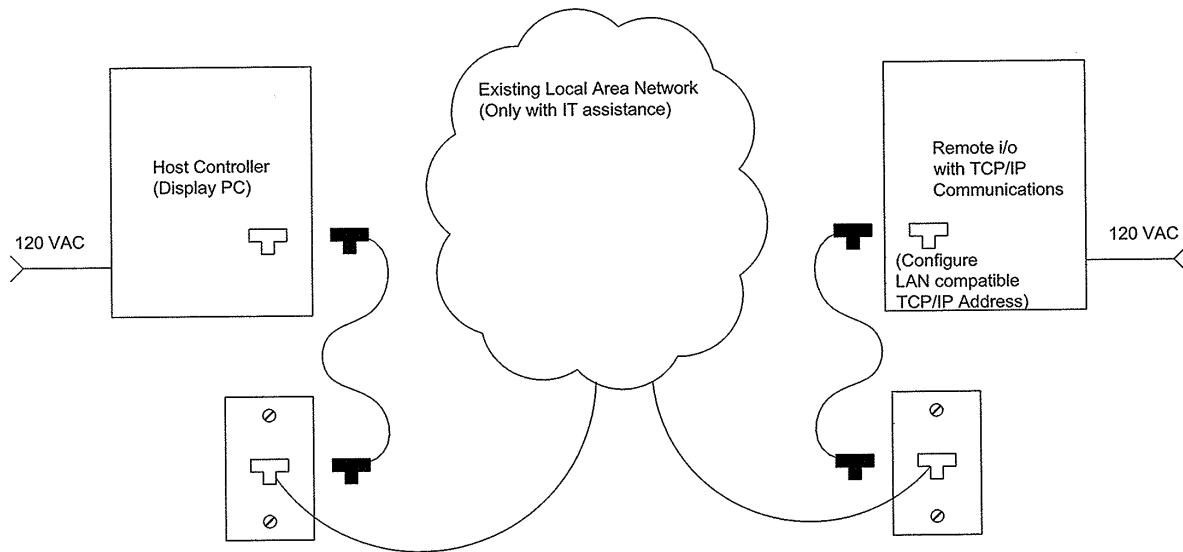

TCP/IP (LAN) Field Wiring

TCP/IP communication wiring and distance extension - TCP/IP appears to be the communications method available today which will have the longest life. For this reason, a little more emphasis will be placed upon details of TCP/IP communication wiring.

We saw that ModBus field equipment can be daisy-chained to existing equipment or to an existing communications cable. TCP/IP started out this way, then called EtherNet. Within a short time, dedicated cables and isolating hubs took over. Part of the reason was cost, but a more powerful reason was ease of maintenance.

In a daisy-chain configuration, when a fault occurs, the system goes dead. Individually removing devices or cable segments is the troubleshooting method. When a star configuration has problems, it is usually only one device, while the remainder remain intact. Almost all hubs have activity lights, which indicate functioning of each port, including the rare jabber-mode failure.

ModBus uses screw-terminal connections. Early Ethernet used vampire taps and military screw-down plugs, later, quarter-turn bayonet plugs. UTP uses RJ-45 modular plugs which are much, much faster to terminate and are finally attached with a push and a click.

The only confusing part of UTP / RJ-45 connections is polarity. For the most part, users never encounter this. All outputs are configured to line up with their associated inputs. A straight-through wired cable is used.

The exception is when two clients are connected together, without an intermediate server. Both clients talk on the same wire. Both listen on the same wire. A crossover cable is needed to permit electrical communication. A pre-wired crossover cable, as implied, has the transmit and receive positions swapped on one end. It costs the same as a pre-wired straight cable.

Fiber optic will not be discussed here. As indicated below, the field remote i/o is UTP copper and the display PC is UTP copper. The media conversion and media should be transparent. Many competitive firms will help you choose compatible converters and media. Expect to pay ~\$100 for a converter, ~\$200 for a 4-port hub with fiber uplink and 20-cents per foot for multi-mode zip fiber. Better everything costs more.

A final digression regards data rate. For many years, ModBus has operated at 9600 bits per second (BPS). It works well. A new installation to this specification will have a long, productive life. Higher data rates are commercially available, at little premium in cost. The isolated ModBus repeater is spec'd to 115,000 BPS. The problem is that data errors increase sharply as data rate increases. It is unlikely that any benefit will be noticed at the increased rate, but exposure to failure has risen substantially.

This discussion was directed to 10 megabit UTP TCP/IP. The communications are reliable and the equipment and media are very inexpensive. Actual throughput will be about 150 BPS, but this so far exceeds the 9600 BPS remote i/o that it appears heaven has been reached. A single 10 megabit channel can easily carry a 10 field marshalling cabinets and four webcams pointed at the parking lot. However, it will not support download of pirated movies and music along with power data and security.

The following graphics illustrate copper and fiber optic connections:

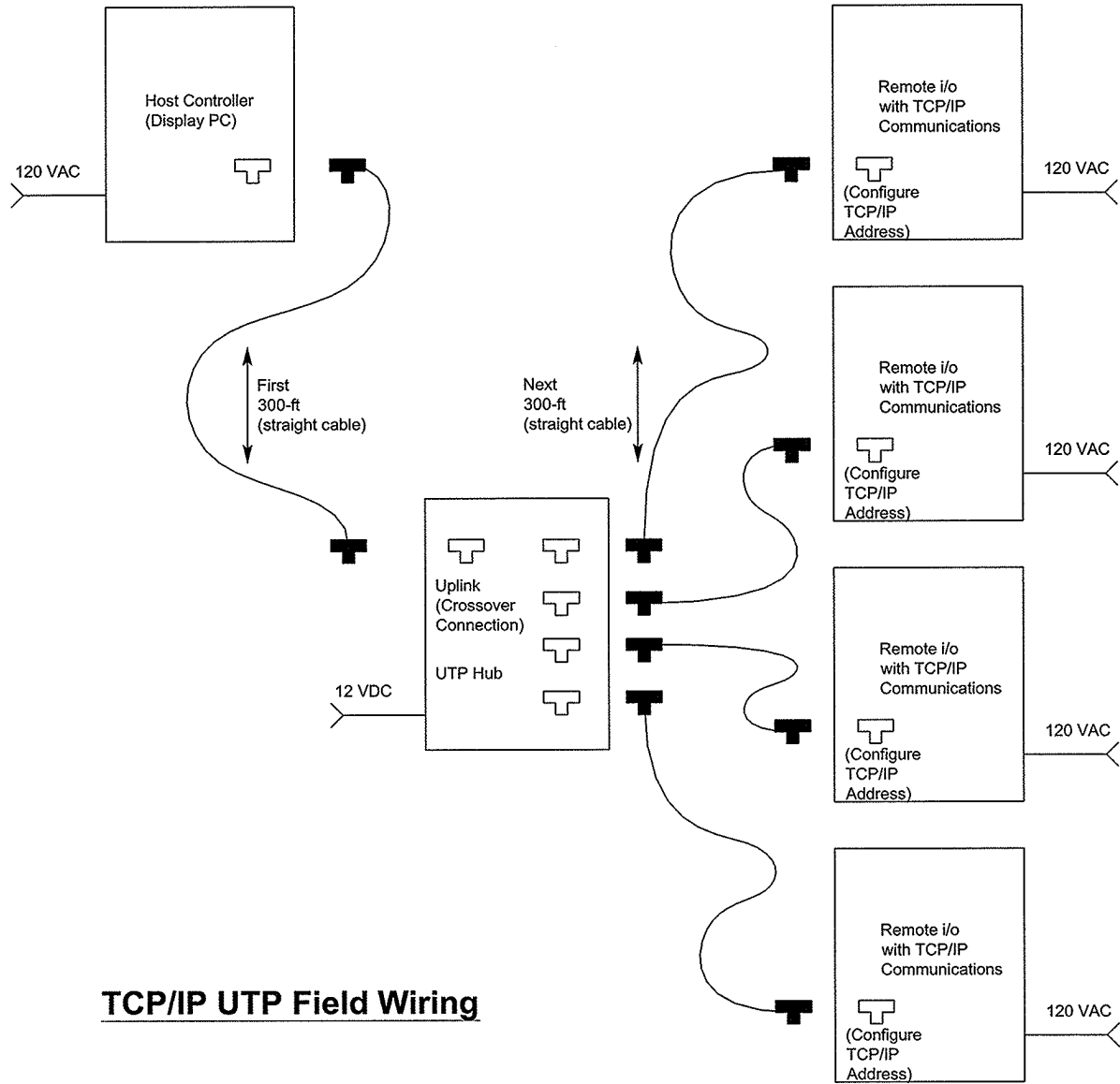

TCP/IP UTP Field Wiring

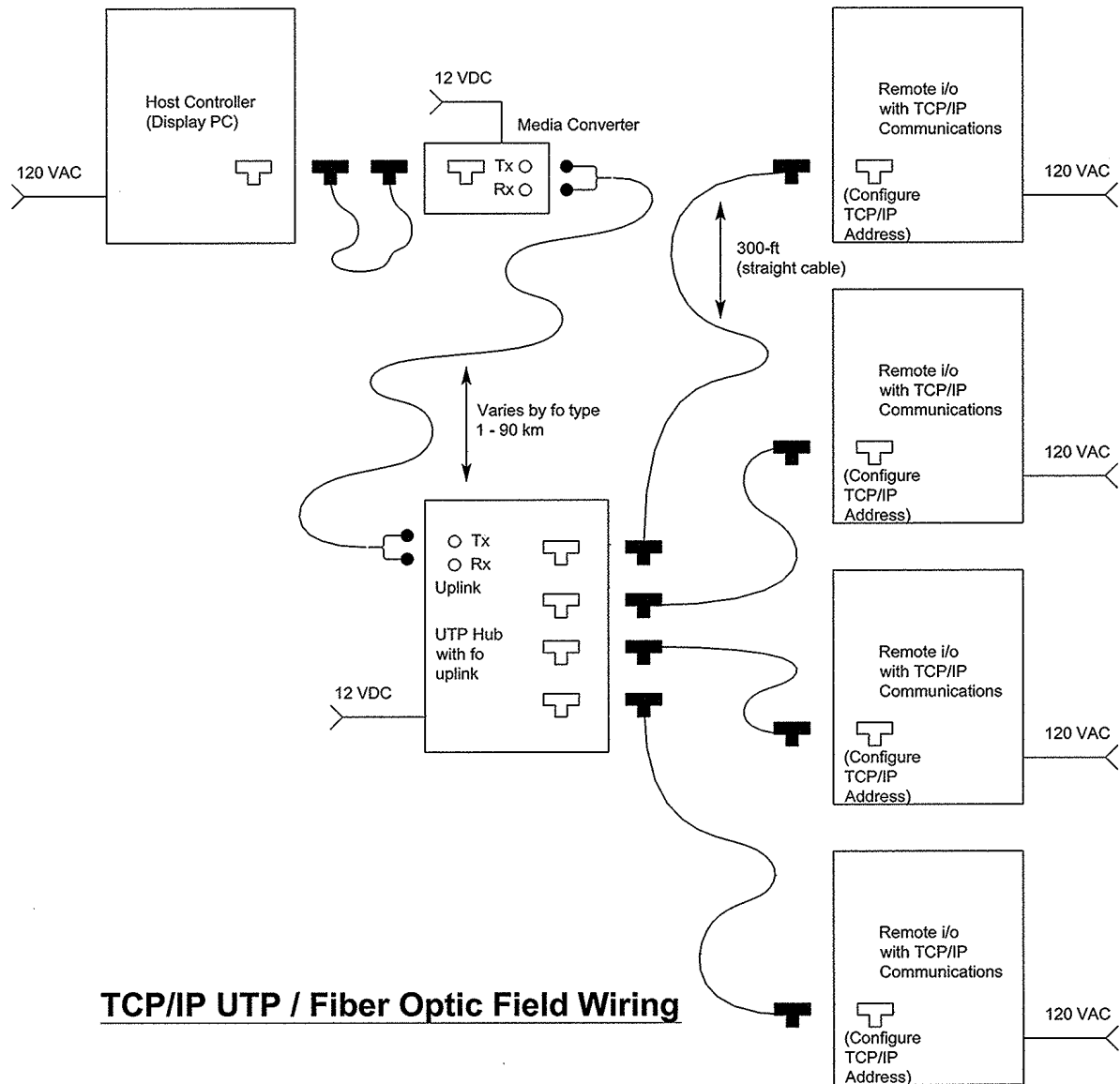

Installation of centralized supervisory control and monitoring - Remote i/o was developed as an extension to plc's, to increase the count of i/o points and permit small separation of the i/o from the processor. When the pc-based "soft plc's" became available, remote was the only i/o available. The soft plc creators adopted the existing remote i/o from Allen-Bradley, Square D, Siemens, and such. Today, we have generic, commodity remote i/o, mostly from the terminal block manufacturers. Again, the standard is communications protocol and configuration to match Allen-Bradley, Square D, Siemens, and such. But, in addition, the new open architecture data communications are becoming available, DeviceNet, BacNet, ProfiBus, and such.

The major innovation, from our perspective, however, is the availability of OLE drivers to link the remote i/o into MicroSoft EXCEL. Suddenly, anyone who can program EXCEL can collect, totalize, make trend graphs and archive data. The only limit is the time available for programming EXCEL.

A tabular display of plant equipment status is very appropriate and lends itself to summary statistics. The downside is that a custom EXCEL spreadsheet is not transportable from Operations to Accounting or to the Corporate office. The reports can be e-mailed, but today's analysts want raw data, not cooked data.

Features of commercial human-machine interface software (HMI) - The alternative to a custom spreadsheet is a canned program with data acquisition, trending, alarming, archiving, backup and external access. The advantages are many. The displays are customizable with drag-and-drop. The remote i/o interface is well tested, but support phone calls included in the purchase price. The alarming and archiving features are powerful. If the server option is purchased, then more copies of the HMI software can be purchased to observe or observe and control the processes. Browser InterNet access is also available. The downside is cost. Think \$5,000, climbing towards \$50,000 for full-blown remote access. HMI suppliers are listed in the links at the end of the course.

Course Summary

This course covered the concepts, methods and available products for digital process control and industrial data communication for process control. Focus was the process industries and manufacturing plants. It introduced concepts, approaches, devices and interconnection block diagrams. The links provide access to further training opportunities, equipment and software suppliers. Following successful review of the reference material and the associated examination, the student should be able to discuss digital process control and industrial data communications with sales persons and management representatives. The student should be able to design prototype monitoring and control systems and write meaningful specifications for more sophisticated monitoring and control systems

Appendix - Controls symbols (from a municipal water treatment project)

INSTRUMENTATION IDENTIFICATION LETTERS DEFINITION

FIRST LETTER		SUCCEEDING LETTERS			
	MEASURED OR INITIATING VARIABLE	MODIFIER	READOUT OR PASSIVE FUNCTION	OUTPUT FUNCTION	MODIFIER
A	ANALYSIS		ALARM		
B	BURNER, COMBUSTION		USER'S CHOICE	USER'S CHOICE	USER'S CHOICE
C	CONDUCTIVITY (ELECTRICAL)			CONTROL	
D	DENSITY (MASS) OR SPECIFIC GRAVITY	DIFFERENTIAL			
E	VOLTAGE (EMF)		PRIMARY ELEMENT		
F	FLOW RATE	RATIO (FRACTION)			
G	GAGING (DIMENSIONAL)		GLASS VIEW DEVICE		
H	HAND (MANUALLY INITIATED)				HIGH
I	CURRENT (ELECTRICAL)		INDICATE		
J	POWER	SCAN			
K	TIME OR TIME-SCHEDULE	TIME RATE OF CHANGE		CONTROL STATION	
L	LEVEL		LIGHT (PILOT)		LOW









M	MOISTURE OR HUMIDITY	MOMENTARY			MIDDLE OR INTERMEDIATE
N	USER'S CHOICE		USER'S CHOICE	USER'S CHOICE	USER'S CHOICE
O	USER'S CHOICE		ORIFICE (RESTRICTION)		
P	PRESSURE OR VACUUM		POINT (TEST CONNECTION)		
Q	QUANTITY	INTEGRATE OR TOTALIZE			
R	RADIOACTIVITY		RECORD OR PRINT		
S	SPEED OR FREQUENCY	SAFETY		SWITCH	
T	TEMPERATURE			TRANSMIT	
U	MULTIVARIABLE		MULTIFUNCTION	MULTIFUNCTION	MULTIFUNCTION
V	VIBRATION			VALVE, DAMPER OR LOUVER	
W	WEIGHT OR FORCE		WELL		
X	TROUBLE FAIL		TROUBLE FAIL		
Y	EVENT, STATE OR PRESENCE			RELAY OR COMPUTE	
Z	POSITION			DRIVE, ACTUATE OR UNCLASSIFIED FINAL CONTROL ELEMENT	







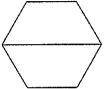
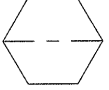











Examples: LSH = Level Switch High
 FIC = Flow Indicating Controller

ABBREVIATIONS













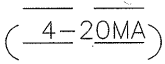

2S1W	TWO SPEED, ONE WINDING	HOA	HAND-OFF-AUTO
2S2W	TWO SPEED, TWO WINDING	HWA	HIGH WATER ALARM
2S2W	TWO SPEED, TWO WINDING	INSTR	INSTRUMENT (TATION)
AI	ANALOG INPUT	NO	NORMALLY OPEN OR NUMBER
AO	ANALOG OUTPUT	OIS	OPERATOR INTERFACE STATION
BCP	BLOWER CONTROL PANEL	PLC	PROGRAMMABLE LOGIC CONTROLLER
CCC	CENTRAL CONTROL CONSOLE	PNL	PANEL
CR	CHLORINE RESIDUAL	PWL	PEAK WATER LEVEL
CTU	CENTRAL TELEMETRY UNIT	RT	RUNNING TIME METER
DI	DIGITAL OR DISCRETE INPUT	SCR	SILICON CONTROLLED RECTIFIER
ES	ELECTRIC SUPPLY	VA-H	HYDRAULIC VALVE OPERATOR
FC	FAIL CLOSED	VA-M	MOTOR VALVE OPERATOR
FLP	FAIL LAST POSITION	VA-P	PNEUMATIC VALVE OPERATOR
FO	FAIL OPEN	VA-S	SOLENOID VALVE OPERATOR



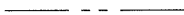

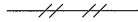
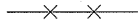
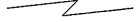
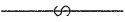





INSTRUMENTATION SYMBOLS

<u>SYMBOL</u>	<u>DESCRIPTION</u>
	INSTRUMENT – FIELD MOUNTED
	INSTRUMENT – PANEL MOUNTED
	INSTRUMENT REAR OF PANEL MOUNTED
	DOUBLE CROSSHATCHING INDICATES EXISTING DEVICE TO BE REUSED OR DEVICE PROVIDED UNDER A SEPARATE CONTRACT
	SINGLE CROSS HATCH PATTERN INDICATES INSTRUMENT FURNISHED UNDER ANOTHER SECTION OF THE SPECIFICATION
	SHARED DISPLAY OR SHARED CONTROL ACCESSIBLE TO OPERATOR
	SHARED DISPLAY OR SHARED CONTROL NOT ACCESSIBLE TO OPERATOR
	COMPUTER FUNCTION – ACCESSIBLE TO OPERATOR
	COMPUTER FUNCTION – NOT ACCESSIBLE TO OPERATOR
	PROGRAMMABLE LOGIC CONTROLLER FUNCTION – ACCESSIBLE TO OPERATOR
	PROGRAMMABLE LOGIC CONTROLLER FUNCTION – NOT ACCESSIBLE TO OPERATOR

	GENERAL INTERLOCK LOGIC OR SEQUENCE CONTROL
	BUBBLER SYSTEM
	RELAY
	VARIABLE SPEED DRIVE
	UNINTERRUPTIBLE POWER SUPPLY
	MOTOR CONTROL CENTER
	MOTOR – SINGLE SPEED
	MOTOR – VARIABLE SPEED
	VENTURI TUBE
	MAGNETIC FLOWMETER
	SONIC FLOWMETER
	TURBINE FLOWMETER
	VORTEX SENSOR
	SINGLE–PORT PITOT
	AVERAGING PITOT
	PARSHALL FLUME
	WEIR
	ORIFICE PLATE

INSTRUMENTATION SYMBOLS

<u>SYMBOL</u>	<u>DESCRIPTION</u>
	FLOAT SWITCH
	DIAPHRAGM SEAL
	CHEMICAL ADDITION POINT
	PROCESS LINE (MAJOR) (LINE WEIGHT DISTINCTION IS OPTIONAL)
	PROCESS LINE (MINOR OR AUXILIARY)
	ELECTRIC SIGNAL (DISCRETE OR ANALOG). 4-20MA MAY BE ADDED TO CLARIFY ANALOG SIGNAL IF DESIRED
	PLC DATA HIGHWAY OR SOFTWARE LINK
	ETHERNET NETWORK
	HART NETWORK
	MODBUS NETWORK
	PROPRIETARY VALVE NETWORK
	PNEUMATIC
	CAPILLARY TUBING
	TELEPHONE LINE
	SONIC SIGNAL
	INSTRUMENT AIR SUPPLY
	PLANT AIR SUPPLY
	ELECTRIC SUPPLY

	PROPORTIONAL
	HIGH SIGNAL SELECT
	LOW SIGNAL SELECT
	PROPORTIONAL INTEGRAL
	RAMP FUNCTION
	ADDER/SUMMER
	SQUARE ROOT EXTRACTOR
	CURRENT TO PNEUMATIC TRANSDUCER
	MOMENTARY PUSHBUTTON
	PUSHBUTTON WITH LOCKOUT
 X/X/X	HAND (MAINTAINED) SELECTOR SWITCH OR MECHANICALLY INTERLOCKED PUSHBUTTONS (SEE CONTROL SCHEMATICS)
	FUNCTION SUBSCRIPTS FOR HAND SWITCH AND PUSHBUTTON CONTROLS
	H/O/R HAND-OFF-REMOTE
	H/VMS HAND-VALVE MASTER STATION
	L/T LEVEL-TIME
	O/O/C OPEN-OFF-CLOSE

Appendix - Controls symbols (for manufacturing machines, ref NFPA 79)

Machine Control Symbols

Selections from ANSI Y32.2/IEEE 315/315A

ANSI Symbol	ANSI Code	IEC 617 Symbol	IEC Code	Description
	CON		KM	Contactor contact open
	CON		KM	Contactor contact closed
	CR		KA	Relay contact open
	CR		KA	Relay contact closed
	TR		KT	Time contact, N.O. - on delay (TDE)
	TR		KT	Timed contact, N.C. - on delay (TDE)
	TR		KT	Timed contact, N.C. - off delay (TDD)
	TR		KT	Timed contact, N.O. - off delay (TDD)
	SS		SA	Selector switch
	PB		SB	Pushbutton N.O.
	PB		SB	Pushbutton N.C.
	PB		SB	Pushbutton mushroom head
	FL		SL	Liquid level switch
	FLS		SF	Flow switch
	PS		SP	Pressure switch
	TS		ST	Temperature switch
	LS		SQ	Limit switch
	PRS		SQ	Proximity switch
	LT		HL	Indicating light
	PL		XS	Plug and socket
	CR		KA	Control relay coil
	CON		KM	Contactor coil
	M		KM	Motor starter coil

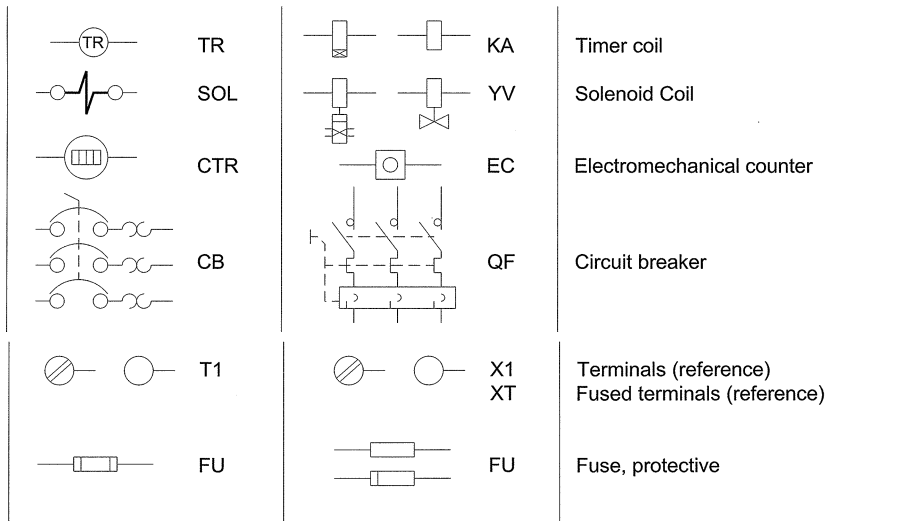

Abbreviations for Machine Control

ABE	Alarm or Annunciator Bell
ABU	Alarm or Annunciator Buzzer
AH	Alarm or Annunciator Horn
AM	Ammeter
AT	Autotransformer
CAP	Capacitor
CB	Circuit Breaker
CE	Circuit Interrupter
CNC	Computerized Numerical Controller
CPM	Contacting
COs	Cable-Operated (Emergency) Switch
CPU	Central Processing Unit
CR	Control Relay
CRA	Control Relay, Automatic
CRH	Control Relay, Manual
CRL	Control Relay, Latch
CRM	Control Relay, Master
CRT	Cathode Ray Tube, Monitor or Video Display Unit
CRU	Control Relay, Unlatch
CS	Cam Switch
CT	Current Transformer
CTR	Counter
D	Diode
DISC	Disconnect Switch
DOS[Display
DR	Drive
EMO	Emergency (Machine) Off Device
END	Encoder

ESTOP	Emergency Stop
FLD	Field
FLS	Flow Switch
FS	Float Switch
FTS	Foot Switch
FU	Fuse
GEN	Generator
GRD, GND	Ground
GUI	Graphical User Interface
HM	Hour Meter
HTR	Heating Element
IC	Integrated Circuit
INST	Instrument
OP;	Instantaneous Overload
I/O	Input/Output Device
L	Inductor
LED	Light Emitting Diode
LS	Limit Switch
LT	Pilot Light
LVDT	Linear Variable Differential Transformer
M	Motor Starter
MD	Motion Detector
MF	Motor Starter – Forward
MG	Motor – Generator
MR	Motor Starter – Reverse
MTR	Motor
OIT	Operator Interface Terminal
OL	Overload
PB	Pushbutton
PBL	Pushbutton, Illuminated
PC	Personal Computer
PCB	Printed Circuit Board
PEC	Photoelectric Device
PL	Plug
PLC	Programmable Logic Controller
POT	Potentiometer
PRS	Proximity Switch
PS	Pressure Switch
PWS	Power Supply
Q	Transistor
QTM	Thermistor
REC	Rectifier
RECP	Receptacle
RES	Resistor

RH	Rheostat
RTD	Resistance Temperature Detector
S	Switch
SCR	Silicon Controlled Rectifier
SOL	Solenoid
SNSR	Sensor
SS	Selector Switch
SSL	Selector Switch, Illuminated
SSR	Solid State Relay
ST	Saturable Transformer
SUP	Suppressor
SYN	Synchro or Resolver
T	Transformer
TACH	Tachometer Generator
TAS	Temperature Actuated Switch
TB	Terminal Block
T/C	Thermocouple
TR	Timer Relay
TSDR	Transducer
TWS	Thumbwheel Switch
V	Electronic Tube
VAR	Varistor
VM	Voltmeter
VR	Voltage Regulator
VS	Vacuum Switch
WLT	Worklight
WM	Wattmeter
X	Reactor
ZSS	Zero Speed Switch