



PDHonline Course E486 (4 PDH)

Grounding System Theory and Practice

Instructor: Velimir Lackovic, MScEE.

2020

PDH Online | PDH Center

5272 Meadow Estates Drive
Fairfax, VA 22030-6658
Phone: 703-988-0088
www.PDHonline.com

An Approved Continuing Education Provider

Grounding System Theory and Practice

Velimir Lackovic, MScEE, P.E.

1. Introduction

System grounding has been used since electrical power systems began. However, many companies and industrial plants have used system grounding methods differently. The problem of whether a system neutral should be grounded, and how it should be grounded, has many times been misunderstood completely. Therefore, grounding of many systems has been based upon past experience rather than engineering analysis.

This course provides applicable information for grounding, such as definitions, reasons for having a system ground, the most desirable grounding method, and so on, and how to measure ground resistance in order to maintain the grounding system.

The definition of grounding is commonly used for both, system grounding and equipment grounding. The National Electrical Code (NEC) defines system ground as a connection to ground from one of the current-carrying conductors of an electrical power system or of an interior wiring system, whereas an equipment ground is defined as a connection to ground from one or more of the noncurrent-carrying metal parts of a wiring system or equipment connected to the system. Following definitions describe power system grounding.

- System neutral ground: A connection to ground from the neutral point or points of a circuit, transformer, motor, generator, or system.
- Grounded system: A system of conductors in which at least one conductor or point is intentionally grounded.
- Ungrounded system: A system of conductors in which there is no intentional connection to ground.
- Solidly grounded: A system in which there is no intentional impedance in ground connection; in such a system the line to ground fault currents may equal three-phase fault current.
- Resistance grounded: A system grounded through a resistance the value of which can be such as to provide either a low- or high-resistance ground system. The low-resistance ground system can have from 25 to several

thousand amperes depending upon the value of the resistance. The high-resistance ground system usually has a value less than 25 A but greater than the value given by $XCO/3$, where XCO is the charging capacitance of the system.

- Reactance grounded: A system grounded through a reactance.
- Resonant grounded: The system grounding reactance value is such that the rated frequency fault current flowing through it is substantially equal to the current flowing between the conductors and the earth (charging current of the system).
- Ground-fault neutralizer: A grounding device that provides an inductive component of current in a ground fault that is substantially equal to, and therefore neutralizes, the rated frequency capacitive component of the ground fault current.

2. Selection of Grounding Method

The selection of a method for power system grounding is very difficult because a large number of factors must be considered before a power system grounding method can be chosen. The following discussion outlines some problems with various grounding methods and explains how and why grounding systems are applied.

3. Ungrounded Systems

Early electrical systems were almost universally operated ungrounded. On small systems an insulation failure on one phase did not cause an outage. The failure could probably be found and repaired at a convenient time without a forced outage. This worked well as long as the systems were small. However, as systems increased in size and voltage rating, an increasing number of insulation failures produced multiple failures and major faults. At first, the reasons for these failures were not understood, and considerable work was done to find why they occurred. Figure 1 below shows a typical ungrounded neutral system.

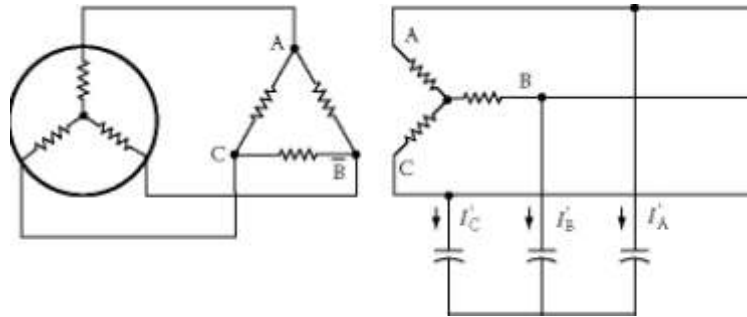

Figure 1. Ungrounded neutral system

Actually, it is a capacitive grounded neutral system, the capacitance being the conductor capacitance to ground. In normal operation, the capacitive current of all three lines is leading the respective line to neutral voltages by 90° , and the vector sum of all three currents is zero. Figure 2 shows what happens when the system of Figure 1 is accidentally grounded.

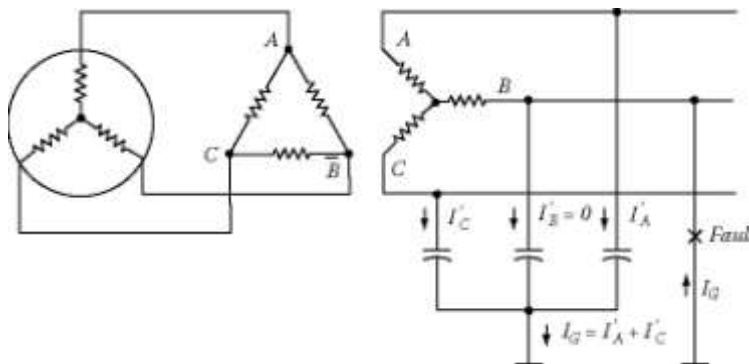

Figure 2. Fault on ungrounded neutral system

The charging current of the faulted phase goes to zero because its voltage to ground is zero. The voltages of the unfaulted phases increase to full line-to-line value with respect to ground, and their charging currents increase proportionally. In addition, because of the 30° shift of the line voltages with respect to ground, the charging currents shift accordingly, and the sum of the charging currents in the unfaulted phases is three times the normal value and appears in the ground, returning to the system through the fault. If the fault can be interrupted, it will most likely be done at a current zero. However, since the current leads by 90° in the capacitive circuit, current zero occurs at the instant of a voltage maximum; thus, if the fault momentarily clears, a high voltage immediately appears across the fault, and restrike of the fault will probably occur.

In the momentary interval of time that the fault has been cleared the excessive voltage charge of the capacitors on the unfaulted lines has been trapped as a direct current (DC) charge. When the arc restrikes again: the capacitors are again recharged by a line-to-ground voltage added to the trapped charge. Thus, a restrike after another current zero clearing is more inevitable, adding another charge.

The phenomenon thus probably becomes an oscillating and self-perpetuating buildup in voltage, which eventually will lead to an insulation failure on another phase and a major two-phase fault. While the first failure may have been a tree branch in the line, the second failure may occur at some other location entirely, perhaps involving expensive equipment insulation, such as a transformer. Thus, the principal advantage claimed for the ungrounded system actually caused troubles that resulted in its abandonment.

These troubles coupled with other factors led to the adoption of grounded neutral systems in some form. Some of the other factors were as follows:

- Because of greater danger to personnel, code authorities frowned on ungrounded systems.
- Equipment costs were generally lower for equipment rated for grounded neutral systems because of the reduction in insulation permissible; because graded insulation could be used, single-bushing, single-phase transformers could be used.
- At the higher voltages being used today (69 kV and above), material savings in transformer costs can be realized by employing reduced basic insulation level (BIL). These savings are in addition to the modest savings above, and may amount to substantial savings in the cost of transformers in the various voltage classes with reduced insulation. The requirements for safely reducing insulation level demand that system neutrals be grounded. Thus, these savings are not available on the ungrounded system.

4. Solidly Grounded Systems

The simplest and most effective method of grounding is to solidly connect the neutrals of any wye-connected transformers or generators to ground. This method has two major advantages: It is simple and inexpensive in that it requires no extra equipment.

It minimizes the magnitude of the overvoltage that will appear on the unfaulted phases during a ground fault, resulting in a reduction in the stress on insulation as compared with other methods.

This is the reason that solidly grounded neutrals are a necessity where reduced BIL insulation is to be used. In spite of the advantages of the solidly grounded system, there are associated disadvantages such that other grounding methods are often used. These disadvantages all stem from the fact that a solidly grounded system produces the greatest magnitude of ground fault current when a fault to ground occurs.

It is realized that with a grounded neutral system perhaps 95% or more of all faults start as a single phase to ground fault. If the amount of ground current that flows can be controlled and the fault cleared promptly, the amount of damage at the fault will be reduced and the fault probably restricted so as not to involve more than one phase.

This may result in preventing bum downs, reduction in the cost of making repairs, and reduction in the frequency or extent of maintenance on the breakers that interrupt the fault. In the case of machines or transformers, the difference in repair cost may be that of replacing a few damaged coils as compared with completely replacing the machine or transformer, which may be necessary where oil fires and explosion follow the transformer fault, or where heavy fault currents melt down coils and burn and weld together expensive areas of laminated electrical steel in the transformer core or machine stator iron. Since the damage done is approximately proportional to I^2t , it is obvious that much more can be done in the reduction of current than by reduction in time.

Under certain conditions, single phase to ground faults can give rise to short-circuit currents 50% in excess of three-phase short-circuit current. Thus, breakers whose ratings make them entirely capable of interrupting.

Three phase faults may be in severe difficulty handling a single phase to ground fault. In view of this, the potential savings in damage and repair costs or avoiding the cost of having to install larger breakers may justify avoiding the simple and inexpensive solidly grounded system in favour of a more complex and expensive system that will provide control of the amount of fault current.

5. Reactance and Resistance Grounded Systems

Reactors are commonly employed as neutral impedance for ground current limitation when the amount of current reduction is small. This is because reactors of low ohmic value to handle large quantities of current can be built quite inexpensively as compared with a resistor for the same current limitation. Reactors to provide current limitation to values less than approximately 30%–50% of value are not practical. This is true partly because the high ohmic values necessary to provide the higher current limitation makes them more expensive than resistors, and partly because high values of reactance grounding approach the conditions of ungrounded systems and give rise to high transient voltages. Resistors are generally used where it is desired to limit fault currents to moderate to small values.

The directly connected resistor is not practical for extremes of current limitation. Reactors are used where a small reduction of current is required, because a resistor large enough to handle the large quantities of current remaining would have to have resistor grids of tremendous cross section or many parallel grid paths, and as a result would be very expensive. On the other hand, if extreme limitation of ground current by resistors is desired, the resistor again becomes excessively expensive. This is because there are maximum values of resistance that it is practical to build into a resistor unit before the cross-sectional area of the resistance conductor becomes so small as to make it too susceptible to mechanical failure from shock, rust, corrosion, and the like.

Thus, to get very high values of resistance, the resistor must be made up by connecting a tremendous number of moderate resistance units in series and it becomes expensive and bulky.

A variation of the directly connected resistor is used, where it is desirable and practical to limit ground fault currents to extremely low values, to avoid the expense and difficulties of the very high value resistance. A distribution transformer is connected between the neutral to be grounded and ground. A resistor is then connected across the secondary of the transformer, as shown in Figure 3.

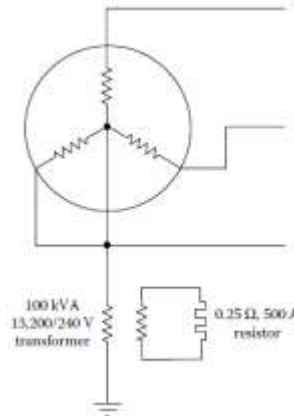

Figure 3. Impedances in the resistor grounded system

The actual 0.25Ω resistor in the transformer secondary is stepped up in value as it appears to the generator neutral by the square of the transformer ratio of $13,200/240$ or 3024 times. Thus, the $1/4 \Omega$ secondary resistor appears as a 756Ω resistor in the generator neutral. This limits the ground fault current to a maximum of 11.5 A. This represents only a small percent of current on the basis of machine full-load current and of the maximum three-phase fault current available. This is representative of the extreme of current limitation.

It accomplishes the ultimate in the reduction of fault damage. Further reduction of fault current would be dangerous, because if it were attempted, the capacitance of the generator and step-up transformer windings and the generator lead bus duct would predominate over the higher values of resistance, and the system would approach the characteristics of the original ungrounded system of Figure 1 with its dangers of arcing grounds.

6. Resonant Grounding

One of the earliest methods of attempting to eliminate the faults of the ungrounded system and still retain the claimed advantages for it was by means of resonant grounding using the Peterson coil. This method attempted to eliminate the fault current that could cause the arcing ground condition. Figure 4 shows the system of Figures 1 and .2 with the Peterson coil applied.

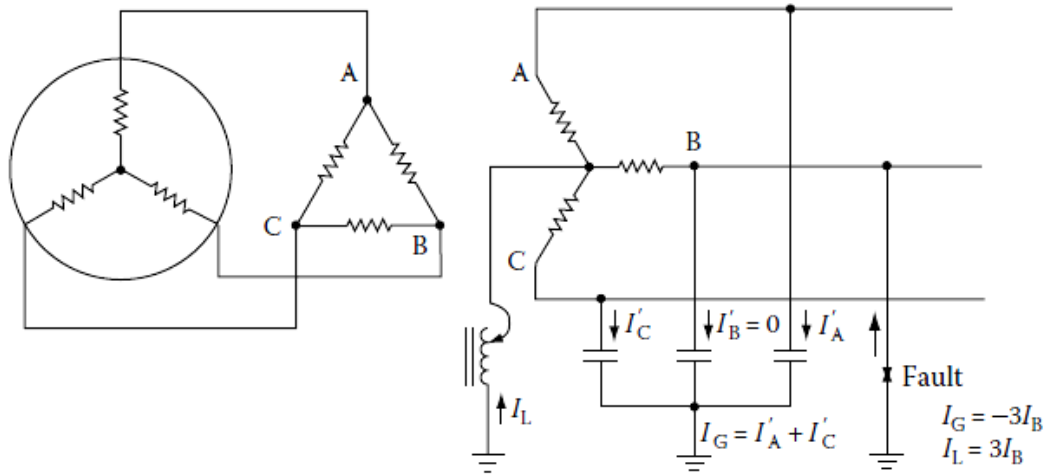

Figure 4. Resonant grounding system

This is simply a tunable, iron-cored reactor connected between neutral and ground. It is tuned so that the current it furnishes matches the current furnished by line capacitance under fault conditions. Under normal system conditions, it does not carry current. However, upon the occurrence of a fault it contributes a reactive component of current through the fault matching the capacitive component. Since the two currents are 180° out of phase, they cancel. This leaves no current at the fault, minimizes the chance of restrike, and thus eliminates the cause of voltage buildup.

The ground-fault neutralizer is said to be effective in 70%–80% of the faults. It is not in great favour because it is not 111% effective, because of its expense, and because of the expense of the equipment necessary to protect it in the 20%–30% of the cases when it does not work. The principal cause of its failure to work is improper tuning. This might seem to be easily corrected, but when it is realized that retuning would be required upon each feeder extension or rearrangement, for each emergency switching condition, or that even if kept properly tuned the system could be detuned by a broken conductor associated with the fault it was to clear, some of the difficulties of its application can be realized.

It can work well in a three-phase radial circuit. However, it is not practical in a tie feeder or network system unless it is blocked off by delta transformers or other zero-sequence impedance isolators so that the tuned setting required can be definitely known and is not variable because of system operating conditions.

7. Grounding Ungrounded Systems

So far the discussion of grounding has assumed a wye-connected neutral to ground. This is not always the case, and in some cases it is not a three-phase system that it is desired to be grounded. For situations of this kind a grounding transformer is used. This may be a conventional wye-delta transformer of suitable rating or a special zigzag wye unit may be used. Once the neutral is established, any of the grounding methods already discussed may be employed, provided the rating of the grounding transformer is adequate for the amount of current permitted by the grounding method used.

Figure 5 shows the setup of a zigzag wye transformer used for the grounding. In the selection of grounding equipment and methods, many factors must be considered. It is desirable from the reduction of fault damage, repair costs, and switching equipment maintenance to limit ground fault current as much as possible. However, the greater the limitation of current, the higher the possible transient overvoltages that will be encountered. This will determine the equipment insulation levels required and the rating of lightning arresters required to protect the equipment, and will consequently affect costs. Therefore, these factors are in conflict with the desire for maximum fault limitation. Whether resistors or reactors are used will determine the degree of overvoltage expected on a given system for a given degree of current limitation and thus affects the selection of the use of resistors or reactors.

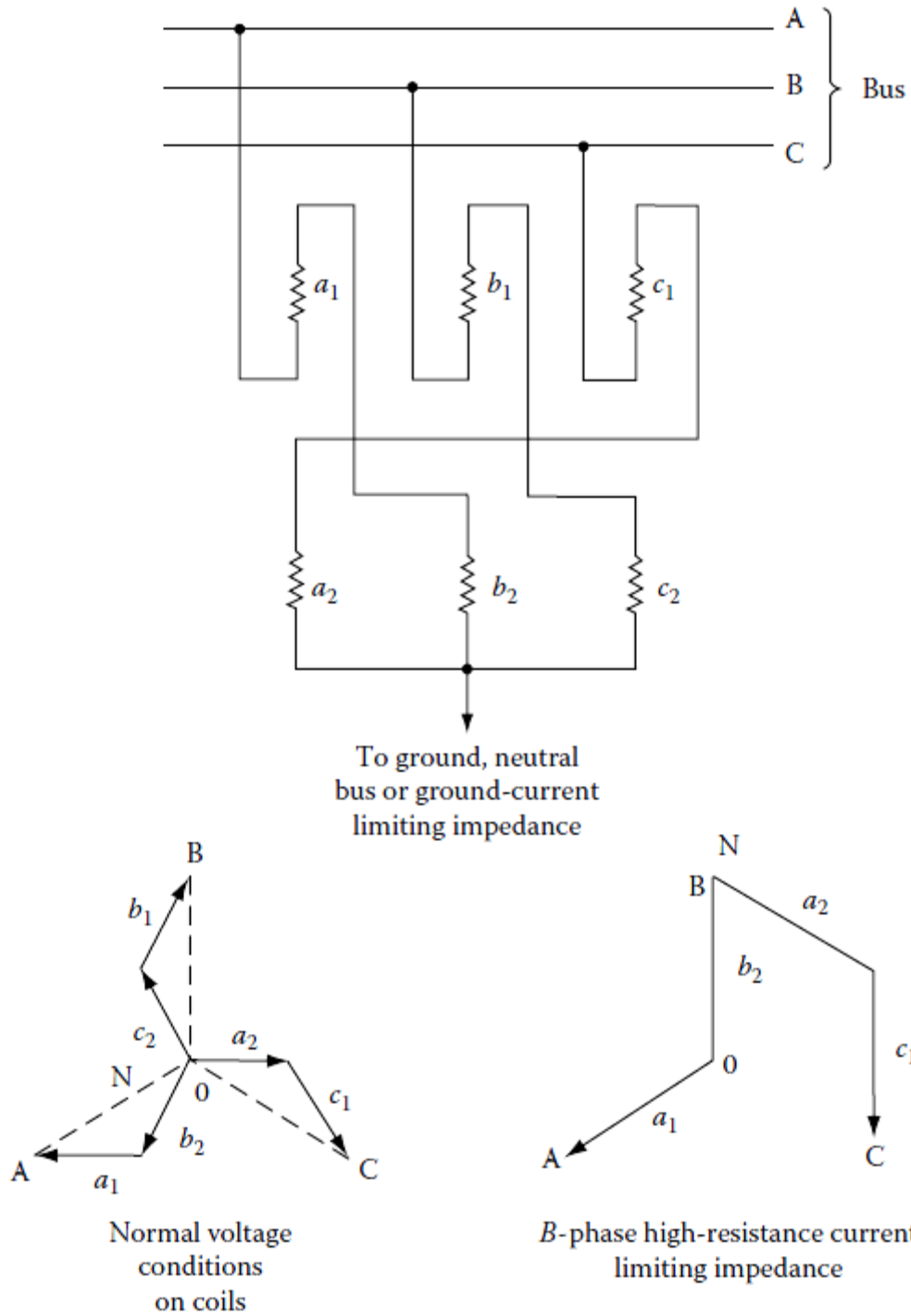

Figure 5. setup of a zigzag wye transformer

Whenever grounding of any kind is used, it is obvious that fault current will flow when a normally ungrounded conductor becomes grounded. It is necessary that relays, fuses, or other protective devices sense and operate to clear the fault. Since

the degree of current limitation employed may well have a serious effect on the ability of these devices to operate as desired, it follows that the degree of current limitation that can be employed may well be determined by the sensitivity of protective devices used, or, conversely, the type and sensitivity of the protective devices required may be determined by the degree of current limitation selected.

However, since a multiplicity of feeders at generator voltage depends upon ground overcurrent relays for their ground fault protection, ground fault current must be kept up to a value that will give adequate relay operating torque for any and all ground faults on them, with reasonable current transformer ratios and relay current ranges. Thus, the selection of the value to which the ground fault is to be limited becomes the problem of making a selection between minimum ground fault current to limit damage, the minimum ground fault that will give adequate protective device operation, and the maximum ground fault current that the generator windings can tolerate before there is danger of the magnetic forces forcing windings out of the generator armature slots.

The extreme ground current limitation can be used only where there are no feeders at generator voltage that must have ground fault protection, and delta-wye transformers isolate the zero-sequence network for which ground fault protection at this very low current level must be provided to a very small number of equipment units. Even then, very special relaying methods must be employed. In conclusion, several important points with respect to impedance grounding of system neutrals are so obvious that they are often overlooked.

Since grounding equipment is electrically active in a circuit only during a ground fault, considerable money can be saved by buying equipment rated for short time duty. Grounding equipment for a station with all underground circuits will be expected to be subjected to very infrequent faults, and since cable faults are usually permanent, repeated reclosing attempts will probably not be made. Under these circumstances a short time rating of the grounding equipment of 11 s or less may be adequate. However, grounding equipment installed in a station having all overhead circuits will be subjected to the cumulative heating effect of perhaps many closely spaced feeder faults during severe storm conditions, each circuit outage being accompanied by several unsuccessful closing attempts. Under these conditions, equipment having a rating on a 10 min or more basis may be inadequate.

Impedance neutral grounding equipment must always be considered hot because if a ground fault occurs in the system, it will raise the neutral to full phase to ground voltage. This not only poses a safety problem but also creates the problem of how to maintain the equipment, unless the machine, bus, or station for which the impedance furnishes the ground is shut down.

Where a multiplicity of grounding units is employed, care must be exercised in switching facilities for their transfer to avoid the danger that someone will get caught operating disconnects for the transfer just as a ground fault occurs. If multiple units are used, care must be exercised to assure that the protective relaying will operate and coordinate properly through the range of conditions possible with the multiple units.

Where impedance grounding is used, no other neutrals in the same zero-sequence system may be grounded except through the same impedance. To do so will shunt or short circuit the original impedance and raise the ground fault current above the desired design value.

8. Selection of Grounding System

As discussed earlier, the various methods of grounding commonly used are solidly grounded, resistance grounded, reactance grounded, and ground fault neutralizer grounded. The ungrounded system, in the true sense of the word, is grounded, because the charging capacitance from the phase conductor to earth acts as the grounding point. The various grounding methods are shown in Figure 6. The selection of a grounding system should be based upon the following systems factors:

- Magnitude of the fault current
- Transient overvoltage
- Lightning protection
- Application of protective devices for selective ground fault protection
- Types of load served, such as motors, generators, etc.

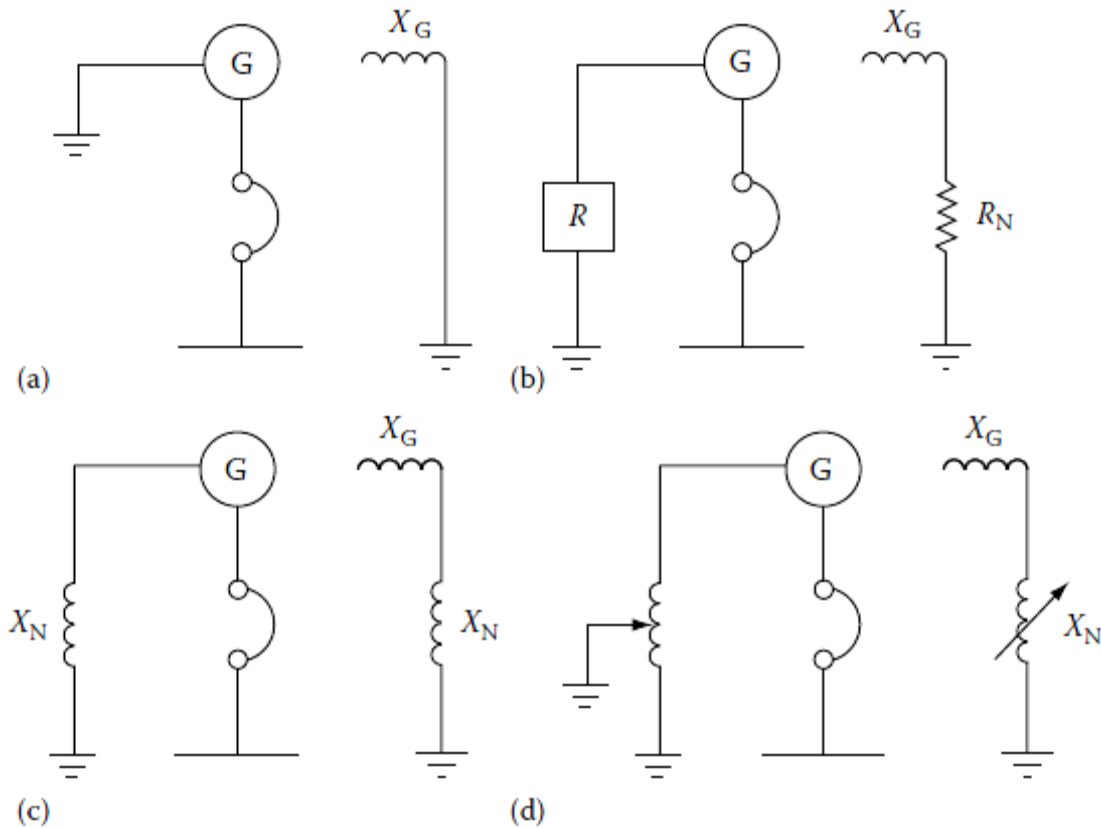

Figure 6. Various grounding methods – equivalent schemes

9. Solidly Grounded System

A solidly grounded system is one in which a generator, transformer, or grounding transformer neutral is directly grounded to earth or station ground.

Because the reactance of source (generator or transformer) impedance is in series with the neutral circuit, this system cannot be considered a zero impedance circuit. In nearly all grounded systems, it is desirable to have the line to ground fault current in the range of 25%–110% of three-phase fault current in order to prevent the development of high transient overvoltage. The higher the ground fault current, the less are the transient overvoltages.

Ground-neutral-type lightning arresters may be applied on this system provided that the ground fault current is at least 60% of three-phase fault current. Another way of expressing this value is to express the reactance and resistance ratios as follows:

Where

X_0 is the zero-sequence reactance

X_1 is the positive-sequence reactance

R_0 is the zero-sequence resistance

Normally, direct grounding of the generator is not desirable because the ground fault current may exceed three-phase fault current. Since the generator is rated for maximum three-phase fault current, it is not desirable to have higher ground fault currents than three-phase fault current. Therefore, most grounded systems having generators are grounded through low reactance values to keep ground fault currents less than three phase fault current. Generally, low-voltage systems (i.e., below 600 V) are solidly grounded. Medium-voltage systems may be either solidly or low resistance grounded.

10.Low-Resistance Grounding

In low-resistance grounding, the neutral is grounded through a resistance of low ohmic value. The reasons for using the resistance grounding system are the following:

- To reduce the ground fault current to prevent damage to switchgear, motors, cables, and the like
- To minimize magnetic and mechanical stresses
- To minimize stray ground fault currents for personnel safety
- To reduce the momentary line-voltage dips by clearing of ground faults

The line-to-ground voltage that may exist during fault conditions can be as high as the voltage present on ungrounded systems. However, the transient overvoltages are not so high. If the system is properly grounded by resistance, there is no danger from destructive overtransient voltages.

11.High-Resistance Grounding

In this system, the neutral is grounded through a resistance of high ohmic value. The line-to-ground voltage of unfaulted phases during a ground fault is nearly equal to line-to-line voltage. If the insulation system was selected for a grounded system, it will be subjected to an overvoltage condition during a line-to-ground fault. The ground fault current available in this type of system is very small,

usually 25 A or less. It should be remembered that when using this system the ground fault current should never be less than the charging current. Moreover, the lightning arresters for this system should be the ungrounded type. This type of system is subject to the following types of overvoltage conditions:

- Ferroresonance type, that is, resonance effects of series inductive–capacitive circuits
- Limited transient overvoltage conditions
- Overvoltage conditions due to direct connection to higher voltages

The reasons for using high-resistance grounding are similar to those for low-resistance grounding except that in this system ground fault current is limited to a very small value.

12. Reactance Grounding

In a reactance grounded system, the neutral circuit is grounded through a reactor. In general, reactance grounding is used for grounding generator neutrals. The value of the reactor chosen is usually such that the ground fault current is not less than 25% of three-phase fault current to prevent serious transient overvoltages during ground fault clearance. The value of X_0 must be less than or equal to 10 times the X_1 value for this type of system.

13. Ground-Fault Neutralizers (Resonant Grounded)

In this system, a reactor having a specially selected high value of reactance is connected in neutral connection to ground. The current that flows through the reactor, during a line-to-ground fault condition, is equal to and 180° out of phase with the charging current that flows in two unfaulted phases. Under this condition, the two currents cancel, leaving the faulted current due only to resistance. Because resistive current is in phase with the voltage, the fault current is quenched when both the voltage and fault current pass through zero axis.

A precaution required in this system is that care must be taken to keep the ground-fault neutralizer tuned to the system capacitance. If any switching is done to take circuits out, the neutralizer reactance values must be changed by adjusting neutralizer taps. Ground-fault neutralizers have been used only to a limited extent and are not as common as the other systems of grounding.

14. Soil Resistance Measurement

The resistance to the earth of any earth electrode is influenced by the resistivity of the surrounding soil. This will depend to a large extent on the nature of the soil and its moisture content. Resistivity may change with depth, temperature, moisture content and can vary from place to place depending on the strata of the soil and rock formation.

The soil resistivity figure will have a direct impact on the overall substation resistance and how much electrode is required to achieve the desired values. It will also influence separation distances between two adjacent earth systems (e.g. HV and LV earths at hot distribution sites). The lower the resistivity, the fewer electrodes are required to achieve the desired earth resistance value. It is an advantage to know the resistivity value at the planning stage as this gives a good indication of how much electrode is likely to be required. This section describes the different methods that can be used to determine the soil resistivity.

The resistivity of any material is defined as the electrical resistance measured between the opposite faces of a uniform 1m³ cube. The accepted symbol is 'ρ' and is measured in ohm-meters (Ωm). Typically soils can vary from a few ohm-meters for very wet loams up to thousands of ohm-meters for granite. In practice soil is very rarely homogenous and so the values indicated should be taken as a rough guide only. The Wenner (four terminal) test is the method for determining soil resistivity. The soil resistivity data can influence the chosen site location as well as the decision on the best type of earthing electrode system to be installed. For example, it helps to decide if it's an advantage to drive rods to a greater depth or whether to increase the surface area by installing more buried tape. The survey can produce considerable savings in electrode and installation costs when trying to achieve the required resistance.

If the results gained from the soil resistivity survey are unclear then soil modelling can be undertaken. With up-to-date techniques a fairly good and accurate soil model can be produced. Also core drilling usually associated with a geo-technical survey will give an accurate soil model and can be used to check measured soil resistivity results. Soil resistivity is also important in determining the separation distances between the HV and LV electrodes at hot distribution substations. A Wenner test could be used but a simpler procedure has been

developed for use at these sites. This is known as the 'one' or 'driven rod method' and gives an average value of soil resistivity.

Once an electrode system is installed then the actual resistance value must be measured and recorded. If this falls short of the design value then additional electrodes will be required to rectify the problem.

15. Wenner Method for Measuring Soil Resistivity at Primary/Grid sites

A four-terminal earth tester is required, equipped with four probes and connecting leads. The latter shall be mounted on reels for easy run-out and recovery and should be checked for continuity and condition prior to use. The calibration of the instrument should be checked before taking any readings, using the test resistors supplied with the instrument. Provision should also be made for a laboratory re-calibration check of the instrument every year.

16. Checks for other buried equipment

Before carrying out any testing, checks shall be made from other utility records, our own cable records and using radio detection equipment, for the presence of any buried cables, earth conductors or other metalwork. These could adversely affect the accuracy of the readings taken, particularly if they are parallel to the measurement route. Conventional metal detectors will only locate very large pipelines or objects close to the surface, so cannot be relied upon.

Location equipment should be used in the inductive mode (to locate pipes which are not connected to the earthing system), and direct mode (to locate any pipes or cables bonded to the earth grid). For the latter, the transmitter is connected to the earthing system at the substation. The routes chosen should preferably be free of long buried metal pipes or lead sheathed cables etc., but if this is not possible the measurement route should be positioned at right angles to these items wherever possible.

The route chosen should not be close and parallel to an overhead line. If the line supports are earthed, then this will adversely affect the readings. If the soil resistivity measurement leads are long and in parallel with an overhead line, then an induced voltage may occur in the leads should fault current flow through the overhead line. To avoid this, measurement routes should preferably be at right

angles to overhead lines. If they must be in parallel, then a separation of 20m or more from the line is required.

17. Wenner Test Method

Figure 7 shows the general measurement setup. The four earth probes should be driven into the ground in a straight line, at a distance 'a' metres apart and driven to a depth of 'P' cm.

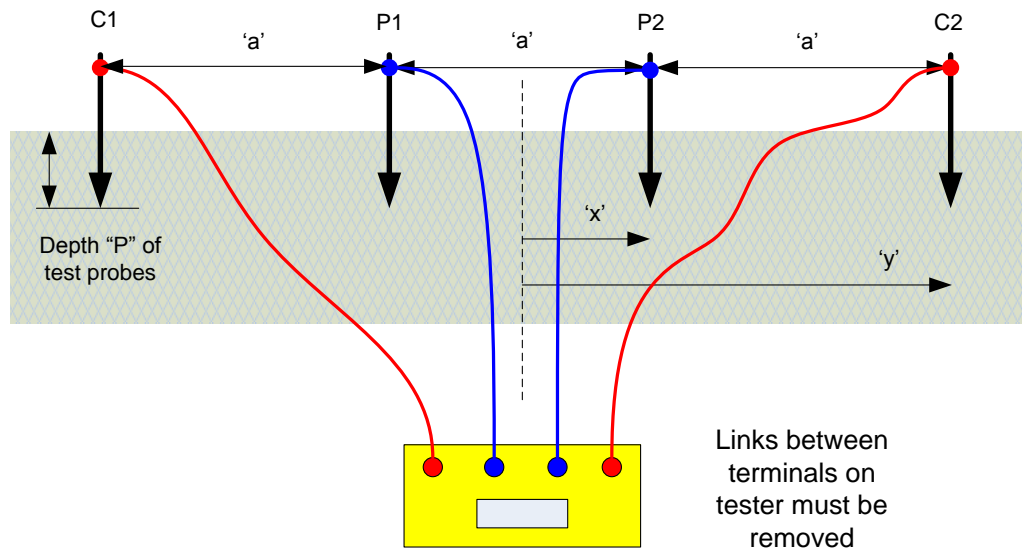

Figure 7. Wenner test method general set up

The maximum depth of the probe should not exceed 20cm nor exceed 1/20th of the probe spacing distance 'a'. A series of resistance readings are taken for various spacings of the probes. For large sites the maximum spacings are increased to enable the soil resistivity to be assessed at a greater depth.

The four probes should be connected to the tester, with the outer probes connected to the C1 and C2 terminals, and the inner probes to the P1 and P2 terminals. The instrument should be kept in a central position and a series of resistance measurements made as the four electrodes are moved out in equal distances from the central point. A calculation is made to determine the average soil resistivity of all layers of soil between the surface and a depth 'd' which is taken to be $\frac{3}{4}$ of the separation distance 'a'. The meter should be left on to allow the built in filters to operate and the value after 30 seconds should be taken. If the reading is varying significantly, this may be due to:-

- Electrical interference
- High contact resistance at the test probes
- Damaged test leads
- Reading at the lower limit of the instrument's measuring capability

If, after investigating the above, the reading is still changing by more than 5%, then record a series of ten consecutive readings over an interval of few minutes, calculate the average and then proceed with the rest of the measurements.

The apparent soil resistivity is then given by $\rho = 2\pi aR$ (Ωm) where:-

ρ = ground resistivity in Ωm

π = 3.142

a = electrode spacing in metres

R = measured resistance in Ω at spacing 'a'

It is a good to plot the results at the testing stage as any wild variations could indicate the presence of buried metalwork that is distorting the results. If this is the case then a new test route should be found.

18. Probes in areas of tarmac or concrete

In some cases, the required position for one of the inner 'voltage' probes may coincide with an area covered with tarmac or concrete. Measurements can usually still be obtained by using a flat metal plate, of approximately 10 to 15cm square, placed on a cloth soaked with saline water, instead of the driven probe. A small weight on top of the plate will help to decrease contact resistance. The usual precautions concerning buried metal structures apply and the area where the plate is used should not contain reinforced steel which runs in the same direction as the measurement route, or the reading will be adversely affected.

19. Problems with depth of probes

Despite suggestions to the contrary in many manufacturers publications, the test probe's depth ('P') need normally only need be inserted to a depth in the range of 5 to 20cm. The outer (current) probes are required to have a reasonably low resistance to earth, sufficient to allow approximately 50mA to flow. However, if the surface soil is dry or frozen, the high contact resistance with the probe will restrict the flow of test current. To overcome this it is recommended that a short steel rod having a smaller radius than the test probe is driven into the soil to a

depth of 20cm and removed. A weak solution of preferably warm, saline water is poured into the hole and the test probe re-inserted. If this does not provide a satisfactory reading, the probe may be driven in a little deeper.

A better arrangement is a cluster of three to five probes positioned 25cm apart and connected together. Probe clusters are normally only required at long test spacings and would introduce an error if used at small spacings. It is very unusual to require probe depths of more than 30cm and precautions will be required to ensure that third party equipment or cables are not damaged if probes are driven to more than 20cm depth. Their installed depth should never exceed 1/20th of 'a'.

20. "One Rod Method" for measuring soil resistivity at distribution sites

At hot distribution substations it is necessary to segregate the HV and LV earths. In order to do this the average soil resistivity value is required. This is a simpler test than the full Wenner test described above. The test is based on measuring the resistance of a single rod that is driven into the ground for a known depth. The resistance measurement and rod dimensions are then used to calculate the average soil resistivity required to produce the measured resistance.

For most distribution substations it is sufficient to drive the rod to a depth of 2.4m and use this reading as the average soil resistivity value. In difficult locations a 1.2m rod is acceptable but if it even this proves difficult to drive in, then it's an early indication that there may be a high resistivity rock layer just below the surface which could give problems achieving the desired electrode value. Once the average soil resistivity is known a separation distance between the HV and LV can be determined. It is a good idea to position the test rod so that it can be incorporated into the final earthing arrangement. Figure 8 shows the general arrangement for this test.

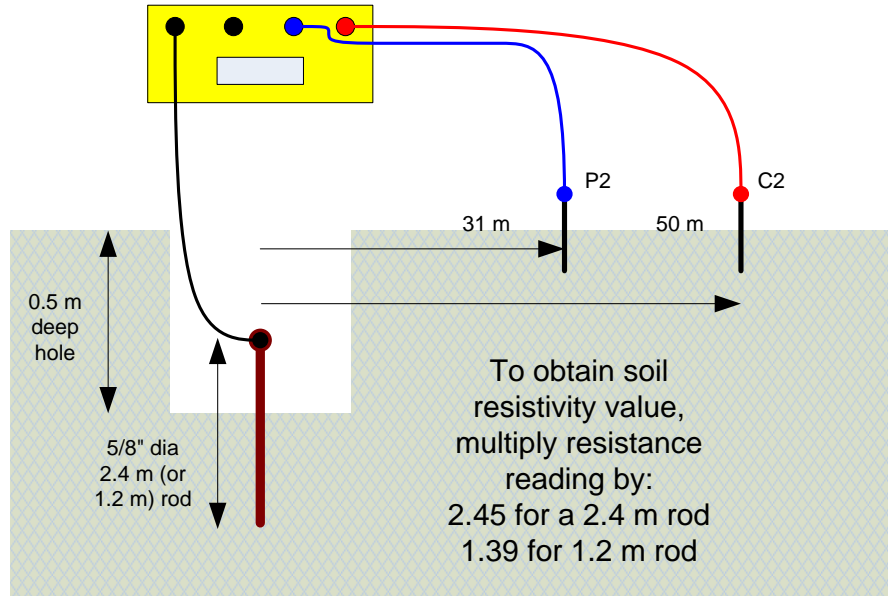

Figure 8. “One rod method” soil resistivity test set up

A further technique would be to take a series of measurements as the rod is driven into the ground at greater and greater depths. When the results are plotted out they could be useful in the following situations:-

- to accurately locate the water table or low resistivity soil layers. The rod resistance will be seen to drop dramatically once this level is reached, assuming the surface material has a higher resistivity. This could influence the decision on whether to install deep drive electrodes or to install a horizontal electrode system.
- at primary and grid sites where readings using the Wenner method are not possible near to the substation. Rods may be driven into the ground even within the substation (once the area is proven free of buried cables/equipment). The results obtained are then used to verify or modify the soil model obtained via Wenner measurements at suitable locations outside the substation. On completion of the test the rod could be incorporated into the main earth grid if appropriate.

The earth resistance of a rod will usually reduce as its driven depth is increased. The resistance of a rod should never increase with driven depth. It is the rate at which the resistance decreases with depth that allows the soil structure and layer resistivities to be determined. Soil structure where the deeper layer has a lower

resistivity than the upper, will produce sudden changes in the gradient of the rod's resistance curve. Where the top layer has a lower resistivity than the lower layers then the structure is more difficult determine, as the test current will tend to continue to flow in the top, lower resistivity layer. The resulting low current density in the higher resistivity layer has little influence on the measured resistance of the rod.

Where a very high resistivity stratum is penetrated, the rod resistance may remain virtually constant with increasing depth. If a further lower resistivity layer is penetrated beneath this, then the rod resistance will again begin to decrease with increasing depth. The technique does suffer from the fact that the rod resistance is determined by conditions close to it and there is often a wide variation between rod resistances (of the same length) obtained at different positions around a site.

21. Grounding studies

A ground mat study has one primary purpose: to determine if a ground mat design will limit the neutral-to-ground voltages normally present during ground faults to values that the average person can tolerate. Equipment protection or system operation is rarely an objective of a ground mat study.

Historically, only utilities and unusually large industrial plants have been concerned with this type of study. However, the trend of power systems toward ever-increasing short-circuit capability has made safe ground mat design a criterion for all sizes of substations. This course will briefly review the theoretical background behind ground mat studies and discuss its application in the design of a ground mat.

22. Justification for ground mat studies

Virtually every exposed metallic object in an industrial facility is connected to ground, either deliberately or by accident. Under normal operating conditions, these conductors will be at the same potential as the surrounding earth. However, during ground faults, the absolute potential of the grounding system will rise (often to thousands of volts) along with any structural steel tied to the grounding system. Because any metal is a relatively good conductor, the steelwork everywhere will be at essentially the same voltage for most industrial installations. Most soils are poor conductors, however, and the flow of fault

current through the earth will create definite and sometimes deadly potential gradients. Ground mat studies calculate the voltage difference between the grounding grid and points at the earth's surface and evaluate the shock hazard involved. Moreover, a computerized ground mat analysis of the type described herein allows the designer to specifically identify unsafe areas within a proposed mat and to optimize the mat design while verifying that the design is safe throughout the area in question.

23. Modeling the human body

To properly understand the analytical techniques involved in a ground mat study, it is necessary to understand the electrical characteristics of the most important part of the circuit: the human body. A normal healthy person can feel a current of about 1 mA. (Tests have long ago established that electric shock effects are the result of current and not voltage.) Currents of approximately 10–25 mA can cause lack of muscular control. In most men, 100 mA will cause ventricular fibrillation.

Higher currents can stop the heart completely or cause severe electrical burns. For practical reasons, most ground mat studies use the threshold of ventricular fibrillation, rather than muscular paralysis or other physiological factors, as their design criterion. Ventricular fibrillation is a condition in which the heart beats in an abnormal and ineffective manner, with fatal results. Accordingly, most ground mats are designed to limit body currents to values below this threshold. Tests on animals with body and heart weights comparable to those of a human have determined that 99.5% of all healthy humans can tolerate a current through the heart region defined by

$$I_b = \frac{0.116}{\sqrt{T}}$$

Where

I_b is the maximum body current in amperes, and
 T is the duration of current in seconds,

without going into ventricular fibrillation. This equation applies to both men and women with 0.116 used as the constant of proportionality, but is valid only for 60 Hz currents. In practice, most fault currents have a DC offset.

Tests indicate that the heart requires about 5 min to return to normal after experiencing a severe electrical shock. This implies that two or more closely spaced shocks (such as those that would occur in systems with automatic reclosing) would tend to have a cumulative effect. Present industry practice considers two closely spaced shocks (T1 and T2) to be equivalent to a single shock (T3) whose duration is the sum of the intervals of the individual shocks ($T1 + T2 = T3$).

Although there are many possible ways that a person may be shocked, industry practice is to evaluate shock hazards for two common, standard conditions. Figure 9 and Figure 10 show these situations and their equivalent resistance diagrams. Figure 9 shows a touch contact with current flowing from the operator's hand to his feet. Figure 10 shows a step contact where current flows from one foot to the other.

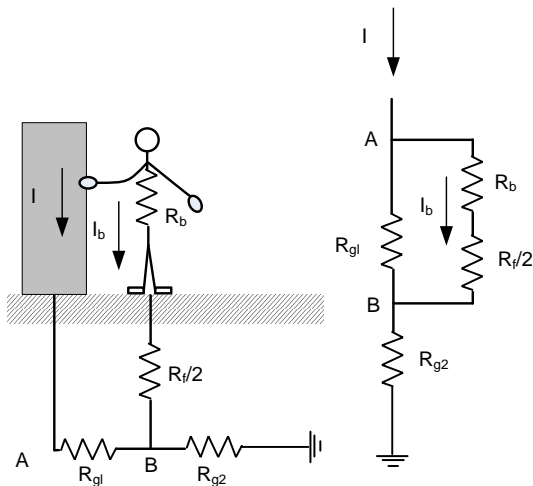

Figure 9. Touch potential

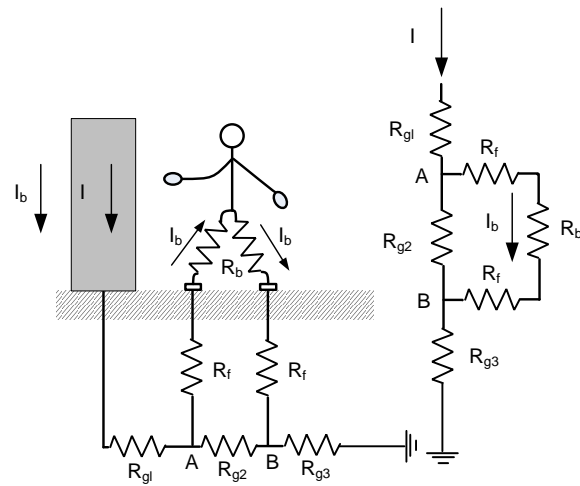

Figure 10. Step potential

In each case, the body current I_b is driven by the potential difference between points A and B. Exposure to touch potential normally poses a greater danger than exposure to step potential. The step potentials are usually smaller in magnitude, the corresponding body resistance greater, and the permissible body current higher than for touch contacts. (The fibrillation current is the same for both types of contact. In the case of step potentials, however, not all current flowing from one leg to the other will pass through the heart region.) The worst possible touch potential (called “mesh potential”) occurs at or near the center of a grid mesh.

Accordingly, industry practice has made the mesh potential the standard criterion for determining safe ground mat design. In most cases, controlling mesh potentials will bring step potentials well within safe limits. Step potentials can, however, reach dangerous levels at points immediately outside the grid. Since the body of an individual who is exposed to an electrical shock forms a shunt branch in an electrical circuit, the resistance of this branch must be determined to calculate the corresponding body current.

Generally, the hand and foot contact resistances are considered to be negligible. However, the resistance of the soil directly underneath the foot is usually significant. Treating the foot as a circular plate electrode gives an approximate resistance of $3 \rho_s$, where ρ_s is the soil resistivity. The body itself has a total measured resistance of about 2300Ω hand to hand or 1100Ω hand to foot. In the interest of simplicity and conservatism, IEEE Std 80-1986 recommends the use of 1000 ohms as a reasonable approximation for body resistance in both models.

This yields a total branch resistance $R = 1000 \Omega + 6 \rho_s$ for foot-to-foot resistance, and $R = 1000 \Omega + 1.5 \rho_s$ for hand-to-foot resistance where ρ_s is the surface resistivity in ohm-meters (Ωm) and R is expressed in ohms (Ω).

Maximum tolerable step and touch potentials are:

$$E_{\text{step-tolerable}} = \frac{(1000 \Omega + 6\rho_s)(0.116)}{\sqrt{T}}$$
$$E_{\text{touch-tolerable}} = \frac{(1000 \Omega + 1.5\rho_s)(0.116)}{\sqrt{T}}$$

Because these voltages are dependent on surface resistivity, most industrial facilities have several different values for each tolerable voltage to match the various surface materials found in the plant.

Although in each of the cases discussed, body resistance shunts a part of the ground resistance, its actual effect on voltage and current distribution in the overall system is negligible. This becomes obvious when the normal magnitude of the ground fault current (as much as several thousand amperes) is compared to the desired body current (usually no more than several hundred milliamperes).

24.Traditional analysis of the ground mat

The voltage rise of any point within the grid depends upon three basic factors: ground-resistivity, available fault current, and grid geometry.

25.Ground resistivity

Most ground mat studies assume that the ground grid is buried in homogeneous soil. This is a good model for most soils and simplifies the calculations considerably. Also, many nonhomogeneous soils can be modelled by two-layer techniques. Although reasonably straightforward, these methods involve quite a bit of calculation, making computation by hand difficult. Normally, the two-layer model is necessary only for locations where bedrock and other natural soil layers with different resistivities are close enough to the surface and/or grid to severely affect the distribution of current.

Of far more serious concern are soils that experience drastic and unpredictable changes in resistivity at various points on the surface. These situations present the following problems:

- Difficulty of modelling the soil in calculations
- Physical difficulties in finding the area boundaries in the field and measuring each area's local resistivity

At present, these cases are normally handled by the inclusion of a safety margin in the value used for soil resistivity.

Because soil resistivity varies with moisture content and, to a lesser degree, with temperature, ideally these measurements should be made over a period of time under different weather conditions. If, for some reason, an actual measurement of resistivity is impractical, Table 1 gives approximate values of resistivity for different soil types. These values are only approximations and should be replaced by measured data whenever possible.

Table 1. Approximate values of soil resistivity

Type of ground	Resistivity $\Omega \cdot m()$
Wet organic soil	10
Moist soil	102
Dry soil	103
Bedrock	104

26. Fault current—magnitude and duration

Since shock hazard is a function of both time and current, a strictly rigorous ground mat analysis would require checking every possible combination of time and current. In practice, the worst shock hazard normally occurs at the maximum fault current. Determination of ground fault current and clearing time normally requires a separate system study. The techniques and problems of making fault studies are covered in numerous sources. Therefore, this section will only cover aspects peculiar to ground grid studies.

After the system impedance and grid resistance have been determined, the maximum ground fault current (assuming a bolted fault) is given as follows:

$$I = \frac{3V}{3R_g + (R_1 + R_2 + R_0) + j(X_1'' + X_2 + X_0)}$$

where

I is the maximum fault current in amperes (note that this is not the same as the current in Ib),

V is the phase-to-neutral voltage in volts,

R_g is the grid resistance to earth in ohms,

R₁ is the positive sequence system resistance in ohms,

R₂ is the negative sequence system resistance in ohms,

R₀ is the zero sequence system resistance in ohms,

X₁'' is the positive sequence subtransient system reactance in ohms,

X₂ is the negative sequence system reactance in ohms,

X₀ is the zero sequence system reactance in ohms.

This current will, in general, be a sinusoidal wave with a DC offset. Since DC current can also cause fibrillation, the current value I must be multiplied by a correction factor called the decrement factor to account for this effect. The exact value for the decrement factor D is given by the following equation:

$$D = \sqrt{\frac{1}{T} \left[T + \frac{1}{\omega} \cdot \frac{X}{R} \left(1 - e^{-\frac{2\omega T}{X/R}} \right) \right]}$$

where

T is the duration of fault in seconds,

ω is the system frequency in radians per second,

X is the total system reactance in ohms,

R is the total system resistance in ohms.

A common mistake in calculating ground mat current is to ignore alternate current paths. In most systems, only a portion of the ground fault current will return to the source through the earth. Because of the time and expense involved in running a full scale short-circuit study to accurately account for the division of fault current, the worst-case situation based upon the full short-circuit capability of the fault source is generally used.

To determine the fault duration, it is necessary to analyze the relaying scheme to find the interrupting time for the current. The choice of the clearing time of either the primary protective devices or the backup protection for the fault duration depends upon the individual system. Designers must choose between the two on the basis of the estimated reliability of the primary protection and the desired safety margin. Choice of backup device clearing time is more conservative, but it will result in a more costly ground mat installation.

27. Fault current—the role of grid resistance

In most power systems, the grid resistance is a significant part of the total ground fault impedance. Accurate calculation of ground fault currents requires an accurate and dependable value for the grid resistance. Equation below gives a quick and simple formula for the calculation of resistance when a minimum of design work has been completed.

$$R = \frac{\rho}{4r} + \frac{\rho}{L}$$

where

R is the grid resistance to ground in ohms,

ρ is the soil resistivity in ohm-meters,

L is the total length of grid conductors in meters,

r is the radius of a circle with area equal to that of the grid in meters.

The first term gives the resistance of a circular plate with the same area as the grid. The second term compensates for the grid's departure from the idealized plate model. The more the length of the grid conductors increases, the smaller this term becomes. This equation is surprisingly accurate and is ideal for the initial stages of a study where only the most basic data about the ground mat is available.

From the above equation it becomes evident that adding grid conductors to a mat to reduce its resistance eventually becomes ineffective. As the conductors are crowded together, their mutual interference increases to the point where new conductors tend only to redistribute fault current around the grid, rather than lower its resistance.

Any computer program that can calculate the grid voltage rise can also calculate the grid resistance (with greater accuracy than the method described immediately above). The grid resistance is simply the total grid voltage rise (relative to a "remote" ground reference) divided by the total fault current. In many cases, such programs perform this calculation automatically. This method can be applied to any grid configuration with any number of conductor elements. However, because the more advanced of these programs calculate grid voltages by solving hundreds of simultaneous equations, the same procedure is usually not practically achievable with hand calculations.

Since grid resistance is viewed as a measure of the grid's ability to disperse ground fault current, many designers are tempted to use resistance as an indicator of relative safety of a ground mesh. In general, however, there is no direct correlation between grid resistance and safety. At high fault currents, dangerous potentials exist within low resistance grids. The only occasion where a low grid

resistance can guarantee safety is when the maximum potential rise of the entire grid (that is, grid potential) is less than the allowable touch potentials. In these cases, the ground mat is inherently safe.

28. Grid geometry

The physical layout of the grid conductors plays a major role in ground mat analysis. The step and touch potentials depend upon grid burial depth, length and diameter of conductors, spacing between each conductor, distribution of current throughout the grid, location of the grid with respect to a different resistivity soil layer, and proximity of the fault electrode and the system grounding electrodes to the grid conductors, along with many other factors of lesser importance. A perfectly rigorous analysis of all these variables would require both simultaneous linear and complex differential equations to exactly describe the distribution of current throughout the grid.

IEEE Std 80-1986 provides the practical method for computing the effects of the grid geometry upon the step and touch potentials.

$$E_{mesh} = K_m K_i \rho \frac{I}{L}$$
$$E_{step} = K_s K_i \rho \frac{I}{L}$$

where

E_{mesh} is the worst-case touch potential at the surface above any individual grid area (i.e., “mesh”) within the mat,

E_{step} is the worst-case step potential anywhere above the mat,

ρ is the soil resistivity in ohm-meters, .

I is the maximum total fault current in amperes (adjusted for the decrement factor)

L is the total length of grid conductors in meters,

K_m is the mesh coefficient,

K_s is the step coefficient,

K_i is the irregularity factor.

Coefficients K_m and K_s are calculated by two reasonably simple equations based upon the number of grid elements, their spacing and diameters, and the burial

depth of the grid.

Because these equations do not take into account the many other factors that influence grid voltages, they are not meant to rigorously model a grid design, but are instead intended to make hand calculation of touch and step potentials feasible. Equations above incorporate an irregularity factor K_i to compensate for the inaccuracies introduced by these simplifying assumptions. Except for applications involving very simple grid configurations, proper selection of a value for K_i is dependent upon the experience and judgment of the designer. K_m and K_s can only be calculated for regular grid designs and must be estimated for irregular grid geometries. Most often, a high value picked for all these factors in the interest of conservatism usually results in an overdesigned mat. Conversely, there is no way to determine if the selected values are too low, resulting in an unsafe ground mat design.

The values of E_{mesh} and E_{step} calculated by above equations must be compared to the tolerable touch and step potentials, $E_{touch-tolerable}$ and $E_{step-tolerable}$ in order to establish whether or not the design is safe. If, in fact, one of the tolerable voltage limits is exceeded, it is sometimes possible, by inspection of the grid, to determine mesh locations where additional cross-conductors should be added in order to achieve a safe design. The more general approach, however, is to uniformly increase the number of grid conductors.

Although this traditional hand calculation method for determining step and mesh potentials was considered acceptable in the past, modern ground mat studies normally use one of the new generation of computer programs. There are two types of computer programs available for ground mat studies. One type performs the aforementioned traditional hand calculations for empirically determining step and mesh potentials, but does it faster and more efficiently than possible by hand. The other type of program calculates the step and touch potentials for each individual grid (i.e., “mesh”) within the overall ground mat. The results, therefore, allow a more detailed analysis of ground mat design effectiveness, pinpointing any mesh locations where shock hazards may exist. The discussion that follows will concentrate on the latter of the two program types.

29. Advanced grid modelling

The key to an accurate ground grid analysis is the individual modelling of each single grid element, rather than the en masse treatment. For example, Figure 11 shows a single grid element located at depth h below the earth's surface in a homogenous medium.

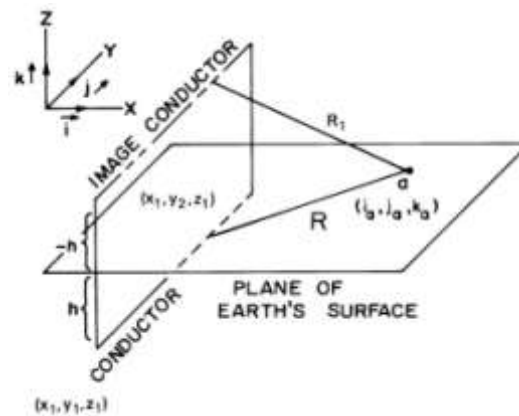

Figure 11. Modelling of single grid element

The element runs from point (x_1, y_1, z_1) to (x_1, y_2, z_1) and is radiating current to the surrounding earth at the linear current density σl (the current per unit length). By integrating σl over the length of the grid element, the current flux ξ can be found at any desired point (a) as follows:

$$\xi = \int_{y_1}^{y_2} \frac{\sigma_1 dy}{4\pi R^2 r}$$

where

ξ is the current per unit area at any point,

σl is the current flowing to ground per unit length of conductor (current density),

$$R = \sqrt{(i - x_1)^2 + (j - y_1)^2 + (k - z_1)^2}$$

$$r = \frac{(i - x_1)i + (j - y_1)j + (k - z_1)k}{\sqrt{(i - x_1)^2 + (j - y_1)^2 + (k - z_1)^2}}$$

NOTE—For the purposes of illustration, Equation above shows a special-case expression that is only valid for lines running parallel to the y axis. The more general form is derived in the same manner, but is much more difficult to follow.

30. Physical model used in calculating voltage at point (a) due to a single conductor

Once ξ has been determined, the E field at the same point can be expressed as follows (assuming a homogeneous soil):

$$E = \rho \xi$$

where ρ is the soil resistivity.

From this, the voltage at point (a) can be obtained by performing the following integration:

$$V_{a1} = - \int_{\infty}^a E dl$$

or

$$V_{a1} = \frac{\rho \sigma_1}{4\pi} \ln \left[j_a - y_2 + \sqrt{(i_a - x_1)^2 + (j_a - y_2)^2 + (k_a - z_1)^2} \right] \\ + \ln \left[j_a - y_1 + \sqrt{(i_a - x_1)^2 + (j_a - y_1)^2 + (k_a - z_1)^2} \right]$$

where

V_{a1} is the absolute potential at any point (a) due to line 1. This process must be repeated for every element in the grid.

This process is complicated somewhat by the presence of the “current density” factor σl in the equations. Although above equations treat σl as a constant, in actuality it varies continuously along the length of each grid element, as well as from element to element. In practice, the variation of σl along the length of an element has little effect upon the calculated voltages, especially when calculating mesh potentials. The variation between elements is very significant, however, and must be obtained by solving a set of simultaneous equations.

When the variation of current density along an element is important, it can be approximated by modelling the element as several segments, each with its own value of σl . Finally, the individual contribution of each grid element can be summed to determine the total voltage at point (a).

An extension of this same basic approach involving multiple images of each conductor is used to perform calculations for multilayer (typically two layer)

soils. The number and complexity of the equations that must be solved is greater, but they can be readily managed using the computer solution methods. The advantages of this analytical method are immediately apparent.

This technique automatically accounts for the finite length of each element, a particularly important consideration when finding the potential at points near the end of an element. It can handle grid designs with large degrees of asymmetry with no sacrifice in accuracy. In cases involving multilayer soils, the effect of the resulting redistribution of currents within such soil systems on touch and step potentials is accurately quantified. Furthermore, since point a can be located anywhere and any number of points can be examined, detailed analysis of the grid design is possible.

The grid layout also determines which points should be checked for touch and step potentials. Touch potentials are normally calculated at the mesh centers, at control stations (where operators may be present), at the entrances to the facility, and at the corners of the grid. Step potentials are rarely a problem inside the grid. However, they may be a danger in the areas just outside the grid, such as the exterior of a perimeter switchyard adjacent to the fence. The worst step potentials usually occur along a diagonal line at the corners of a grid. Shock hazard voltages can be accurately determined at all such critical locations using these calculating procedures. In addition, the absolute (earth) surface potentials and the ground potential rise (EPR) of the grid is an automatic by-product.

31. Input/output techniques

The increased use of personal computers in the workplace has led to higher expectations for all software. Ground mat analysis programs are no exception. Since the grid layout is so important to this class of programs, they are especially well suited to graphical input/output methods. First generation programs typically required the user to input the end coordinates of each grid element, and simply printed the calculated voltages at user-designated coordinates. Although the basic calculations are correct, interpretation is difficult and checking the data entry is laborious and time-consuming.

Most modern ground-mat analysis programs support some form of graphical output, either two-dimensional or three-dimensional. Many programs allow the user to draw the grid design and then calculate the endpoints internally. With

proper preparation, others are capable of reading the grid design directly from CAD drawing files. Some programs can select the points to calculate automatically or plot equipotential lines. Ground mat programs can also do material take-offs as well as material and labor cost estimates. The latest programs not only calculate raw voltages, they compute the mesh and touch potentials and compare them to the limits (also automatically calculated). New programs can also manage multiple surface materials and soil layers. They can also store intermediate calculations for later use. Advanced programs can edit their input data, ignoring unimportant detail.

32. Conclusion

The adaptation of classical analytical techniques and calculating procedures to the digital computer has made ground mat analysis much more precise, reliable, and useful. Many ground mat analysis programs can all but eliminate unnecessary grid overdesign and, if properly applied, all ground mat analysis programs can detect unsafe conditions that might otherwise go undiscovered until made apparent by serious mishap.

A ground mat study requires, as a minimum, the following data:

- Soil resistivity, both at the level of the grid and (if appropriate) at any other soil layer
- Resistivity of any special soil surface dressing material
- Estimated duration of a ground fault
- System frequency
- System X/R ratio
- Maximum symmetrical ground fault current, both future and present
- Grid layout showing the precise location of every conductor
- Coordinates where the potential rise must be calculated

Consideration of all this information will lead to a reliable, accurate, and useful study.

Although ground mat analysis programs provide an invaluable design tool, they are by no means infallible. If at all possible, a followup investigation should be made of each grid after it has been installed. This should include a measurement of grid resistance at the very least, and preferably the measurement of the AC mesh potential at several locations within the grid. If these measured values differ

appreciably from the calculated ones, the results of the grid study should be rechecked and supplemental rods or buried conductors provided as required to establish safe conditions.