



PDHonline Course M208 (4 PDH)

Overview of General Purpose & Industrial Ventilation Systems

Instructor: A. Bhatia, B.E.

2020

PDH Online | PDH Center

5272 Meadow Estates Drive
Fairfax, VA 22030-6658
Phone: 703-988-0088
www.PDHonline.com

An Approved Continuing Education Provider

Overview of General Purpose & Industrial Ventilation Systems

Course Content

Ventilation can simply be described as the process of changing air in the enclosed space. Fresh air is introduced and circulated throughout the building and the vitiated or stale air is removed or diluted. Ventilation is necessary in:

- 1) Preventing depletion of the oxygen content of the air;
- 2) Preventing undue accumulation of carbon dioxide and moisture;
- 3) Preventing an undue concentration of body odours and other contaminants such as kitchen or tobacco smoke;
- 4) Preventing an undue concentration of particles carrying bacteria;
- 5) Removing body heat and heat liberated by the operation of electrical, mechanical and process equipment (e.g. artificial lighting and machinery)

The rate of ventilation, measured in cubic foot per minute (CFM) or liters of air per second (lps) must be sufficient to satisfy the following three requirements:

- 1) Sufficient air movement throughout the space to prevent the formation of pockets of stale air
- 2) Sufficient fresh air supply and foul air exhaust to limit the level of air pollution from all sources in the building, including humidity
- 3) Reduction of air temperature, within the limits set by the climate, by the removal of heat generated within the building or supplied by the sun

General Purpose Ventilation

General Purpose Ventilation involves removing heat, odours, and/or contaminated air from inside the building and replacing it with outside air. It may be provided by natural draft, by exhaust fans, by supply fans or by a combination of supply and exhaust fan/s. Although natural ventilation is often relied, its effects are uncertain, unreliable and difficult to control. Mechanical ventilation system using fans have become an essential part of good ventilating systems for the following reasons:

- 1) They operate irrespective of internal temperature and external winds.
- 2) They can be more easily and accurately controlled.
- 3) They can often be used for either extract or intake, and therefore cater for a wider variety of winter and summer conditions more easily.
- 4) On extract much smaller inlet openings are necessary in building structures for air replacement, due to the greater suction pressure provided by a fan.
- 5) On intake they give positive air movement for relief from radiant heat, can incorporate filters for use in dusty atmospheres, and heaters if required during cold weather to augment the normal heating system of the building.

General or dilution ventilation is not an adequate alternative to containment of an impurity at source. This is done by local exhaust ventilation. However, it may be necessary to dilute the impurity to an acceptable level where complete control at source is not reasonably practical. These aspects are discussed in detail in section# 5.

Factors Affecting Ventilation Rates

The need for fresh air in the workplace is influenced by a number of factors; in particular the space available per occupant, the work activity, the habits of the occupants (e.g. smoking) and the presence of other sources of airborne contaminants such as process plant, heaters etc.

Quantity and Distribution of Air: The fresh air supply is required to maintain an acceptably non-odorous atmosphere (by diluting body odours and tobacco smoke) and to dilute the carbon dioxide exhaled. The quantity may be quoted per person and is related to the occupation density and activity within the space. The proportion of fresh air introduced into a building may be varied to achieve economical operation. When the fresh air can provide a useful cooling effect, the quantity is controlled to balance the cooling demand. However, when the air is too cool, the quantity is reduced to a minimum to limit the heating load. Similarly, when the air is too warm or humid, the quantity is reduced to minimum to reduce the cooling load.

Transfer of heat/moisture: Air circulation is required to transfer the heat and humidity generated within the building. In simple systems, the heat generated by the occupants, solar heat and heat from electrical and mechanical equipment may be removed by the introduction and extraction of large quantities of fresh air. In more elaborate systems air may be recirculated through conditioning equipment to maintain the desired temperature and humidity. The air circulation rates are decided in relation to the thermal or moisture loads and the practical cooling or heating range of the air.

Air movement: Air movement is desirable, as it contributes a feeling of freshness, although excessive movement should be avoided as this leads to complaints of draughts. The speed of an air current becomes more noticeable as the air temperature falls, owing to its increased cooling effect. The design of the air-distribution system therefore has a controlling effect on the quantity and temperature of the air that can be introduced into the space. The quantity of fresh air should not be increased solely to create air movement; this should be affected by air recirculation within the space or inducing movement with the ventilation air stream.

Air flows within the building should be controlled to minimize transfer of fumes and smells, e.g. from kitchens to restaurants and the like. This is achieved by creating air pressure gradients within the building, by varying the balance between the fans introducing fresh air and those extracting the stale air. For example, the pressure should be reduced in a kitchen below that of the adjacent restaurant. Care should be taken, however, to avoid excessive pressure differences that can cause difficulty in opening doors or cause them to slam. In other cases, such as computer rooms, the area may be pressurized to minimize the introduction of dust from adjacent areas.

Fire and smoke control: Air circulation system may be designed to extract smoke in the event of a fire, to assist in the fire fighting operations and to introduce fresh air to pressurize escape routes.

Air purity and filtration: A ventilation or air-condition system installed in a building should clean, freshen or condition the air within the space. Special air filters may be required to remove contaminants or smells when air is recirculated. Positions of air inlets and extracts to the system are most important and care should be taken in their location. Inlets should not be positioned near to any flue outlets, dry cleaning or washing machine extraction outlets, kitchens, WC's etc. When possible, air inlets should be at high level so as to induce air from as clean an area as possible. If low level intakes are used, care should be taken to see that they are positioned well away from roadways and car parks.

Climatic Conditions: Ventilation systems must be considered for three climatic conditions that occur during the year--winter, summer, and spring-fall. A high rate of ventilation is required in summer to deal with the build-up of heat from solar radiation, production processes and high internal heat load, whereas in winter a very low air changes per hour (ACH*) is required, simply to prevent vitiation of the air and to remove odours and water vapor. This variation in requirements may range from 6-15 ACH in summer and 2 ACH in winter.

* ACH - The number of air changes per hour is the number of times one volume of air is replaced in the space per hour.

Winter Ventilation

A heating system with adequate capacity is needed in the winter to maintain environmental conditions inside the building. Even during the coldest part of the winter, when the heating system is running at full capacity, some ventilation is still required. Fresh, outside air must be introduced into the building to remove the warm, moisture-laden air. If moist air is not removed, high humidities and excessive condensation will occur. Studies have shown that humidities over 90% foster rapid deterioration of structural components, and damp, uncomfortable environmental conditions.

Condensation occurs when warm, humid air comes into contact with a cold surface, such as glass or structural members. The air in contact with the cold surface is cooled to the temperature of the surface. If the surface temperature is below the dewpoint temperature of the air, then water vapor in the air will condense onto the surface. For example, condensation occurs, if indoor air at 70° F and 70% relative humidity comes in contact with a surface that is 60° F or colder. *This tendency is increased with low ambient temperatures, high wind velocities and high internal humidities.*

Exhausting moist air and replacing it with heated outside air is effective in eliminating condensation and other problems resulting from high humidities. *Whenever ventilation rates are increased in the winter, the heating requirements also increase. Consequently, it is necessary to determine a ventilation rate that will maintain humidities below the damaging level and, at the same time, keep the heating requirements as low as possible. Ventilation requirements in winter are generally on the order of two to three air changes per hour. The higher the inside temperature, the lower shall be the air exchange rate that is required to maintain humidities below the damaging level.* Besides controlling humidity, this minimum ventilation rate is required to remove any gases of combustion that may be present as a result of leakages around the heater and ducting when a direct-fired heating system is used.

To conserve energy in winter, the ventilation shall operate under reduced flow to take advantage of increased air infiltration. The ventilation fans could be equipped with a flow controller such as a two-speed fan. A manual switch or an indoor humidistat could be used to increase flow for quick removal of odours, moisture, and fumes. In addition, an outdoor temperature controller could be installed to increase air flow in mild weather.

Summer Ventilation

The main purpose of a ventilation system during the summer is to prevent the air temperature rising too high above the outside air temperature. The reason for the higher air temperature indoors may be because of the large influx of solar radiation and large dissipation of heat by power and process equipment. The amount of sensible heat gain is essentially from four components:

- Q1 = Solar heat gain through structure
- Q2 = Heat from the electrical apparatus/machinery
- Q3 = Heat dissipation from other equipment/processes
- Q4 = Body heat of occupants

The total heat gain is $\Sigma Q = Q1 + Q2 + Q3 + Q4$

The ventilation rate can then be calculated from equation:

$$V = Q / (1.08 * \Delta T)$$

Where:

- 1) Q = sensible heat load (Btu/h)
- 2) V = volume flow rate of outdoor air introduced in cubic feet per minute (cfm)
- 3) ΔT = temperature difference between outdoor and indoor air °F
- 4) 1.08 = A constant derived from the density of air at 0.075 lb/cu ft under average conditions, multiplied by the specific heat of air (heat required to raise 1 lb of air 1°F), which is 0.24 Btu/lb°F, and by 60 min/h. The units of this constant are Btu min/cu ft °F h.

The ventilation calculation is an iterative process as there are two variables V and ΔT . Setting different values of ΔT will provide different cfm values. Fixing ΔT is basically setting the value of indoor air temperatures as the design outdoor air temperatures can be obtained from ASHRAE handbook of fundamentals, which provides weather data for various geographical location. As the temperature difference between outside and inside air temperature decreases the ventilation rates increases. *Regardless of how high the ventilation rate is in the summer, the inside air temperature during the day will never be as low as the outside air temperature.* The inside air temperature can at the best approach outdoor ambient temperature at very high ventilation rates. But the disadvantage of increased ventilation rate is the increased cost for fans and accessories, as well as increased operating costs. If one is interested in maintaining an inside air temperature below outside air temperature, then evaporative cooling or some other means of refrigeration must be used.

A generally accepted ventilation rates for temperature control in the summer range from one air change every three minutes to three air changes per minute.

Spring-Fall Ventilation

The recommended ventilation rates for the spring-fall seasonal periods will be somewhere between rates required for summer temperature control and those required for winter-humidity control. The spring-fall periods are characterized by some times that are relatively cool and cloudy and other times that are warm and sunny. No special provisions are necessary for maintaining ventilation rates during this period except for the temperature and humidity controls that will determine the amount of ventilation necessary.

Ventilation for Air Quality

The sources for odour are many: body odours, tobacco smoke, vehicle exhaust, food preparation, garbage, finishing materials, furnishings and even the wetted coils of air conditioning systems as they become dirty. There are a number of other items that can affect indoor air quality. From cigarette smoke to ozone from laser printers all of these can add to the challenges of maintaining good indoor air quality. A variety of airborne particles, such as dust, smoke, pollens and organisms are contained in the outdoor air and are brought indoors along with the ventilation air. Lot of contaminants are generated indoors by the activities of the occupants. Limiting the concentrations of these contaminants is an important aspect of air quality control.

There are two basic methods of ventilation for air quality control. The simplest and most widely accepted technique for controlling odours is to dilute them with outdoor air. A sufficient amount of fresh air is brought into the space, adequately mixed with the room air to reduce the concentration, and then exhausted from the room in the mixed condition.

If the source of the contaminant can be isolated, a second approach may use the dilution as well as isolation or removal of particles through dedicated exhaust systems. This is the

approach used with kitchen range hoods and in venting fuel-fired systems, where the products of combustion are captured and exhausted with draft control air up the chimney.

A modification of the dilution approach involves recycling and conditioning the air by passing it through a device that will remove the offending contaminant or odour, and return the freshened air to the occupied space. A common example of this approach is the recirculation of indoor air through a filter or gaseous filtration based on principle of adsorption. The adsorbent material is usually activated charcoal, which is very effective in removing the volatile organic compounds (VOC's). This technique is much more effective compared to dilution when the nature of contaminant is known. This is discussed further in detail in section# 3.

Ventilation for Humidity Control

Buildings, like our bodies, exchange moisture and air with the environment, as well as exchanging heat. Although most of this moisture exchange occurs during the exchange of fresh air, some exchange occurs through a building's skin. This can cause problems in either hot, humid climates or very cold ones.

In hot, humid conditions, as hot and humid air contacts cold surfaces; condensation can occur. Almost all common building materials, including gypsum board, concrete, clay masonry, wood etc. are easily permeated by moisture. Most surface finishes are also permeable. The moisture vapor in the air condenses to form visible droplets of water on the ceiling. A much less visible moisture threat occurs within walls, ceilings, or floors. The results can be annoying and more serious damage to the building structure can result.

In cold climates, the air outside contains relatively little moisture, even though the RH may be high. By contrast, inside air contains much more moisture per unit of volume, despite its probably lower RH. The result is a flow of vapor from high vapor pressure to low vapor pressure (typically warm to cold). Such a flow occurs when the temperature within the wall (floor, etc.) drops low enough for this vapor to condense. Insulation can then become wet and thereby less effective, since water conducts heat far better than the air pockets. Worse yet, moisture damage can occur, such as dry rot in wood structural members. The usual remedy for such a potential problem is to install a vapor barrier within the building envelope. These barriers are commonly made of plastic film installed with as few holes as possible.

Outdoor air is always infiltrating a building, gradually replacing the indoor air. This unintentional source of fresh air becomes a problem when temperatures outside are very different from those inside, especially when strong winds force outdoor air indoors fast enough to produce noticeably cold (or hot) drafts. Some fresh air is always desirable in buildings, but it should be the user's control of how and where it is admitted.

Humidity control strategies will depend on the climate of the region and its seasonal and daily cycles. Surface condensation is sensitive to daily variations in climate and operation.

Ventilation for humidity control is least effective in the fall, because the drying capacity of the outside air is at a minimum and the moisture supply rate is highest, due to moisture given off from storage in furnishings and building materials.

Lowering the relative humidity inside the house in summer, using an air conditioner or dehumidifier, will lower the moisture content of the interior materials and thus the moisture supply from storage in fall and winter.

Introducing colder, drier outside air to the space in winter serves to dilute the water vapor, enabling the drier mixture to pick up moisture produced in the space, and to exhaust the mixture either up the chimney through an exhaust fan or by exfiltrating through the house envelope. The rate of moisture removal by this means will depend on the moisture content of the outdoor air and the rate of flow of the room air to the outside.

In general, a minimum continuous ventilation rate of 35 liters per second is recommended to maintain air quality in houses under normal circumstances, with a capability of 75 liters per second or more for intermittent use for humidity control and contaminant removal. Natural forces cannot be relied upon to provide such rates under all circumstances and a positive, mechanical system is desirable.

Always provide a dedicated exhaust fans in high moisture production areas such as the bathroom and the kitchen. It is also the principle employed in the automatic clothes dryer, where room air is brought in to pick up moisture from the wet clothes and exhausted to the outside. Another approach to indoor humidity control would be to use a device to remove moisture from the air by absorption or condensation and return the dried air to the space. A typical example of this is the indoor dehumidifier. Since its capacity is markedly reduced at low humidities, it is not capable of removing much moisture below indoor relative humidities of 40%. It could, however, be effective in helping to control indoor humidity levels in those areas where 40% can be tolerated and where higher humidities are experienced.

Section# 2 TYPE OF VENTILATION SYSTEM

Three common ventilation system designs are

- 1) Mechanical Ventilation, which can be further classified as extract system, intake supply system and the balanced ventilation system.
- 2) Displacement Ventilation, which either uses the principle of natural ventilation of supplying fresh air at lower levels and exhausting at higher elevations or mechanically introducing air at lower levels and exhausting at higher elevations.
- 3) Natural Ventilation using principles of building stack effect

In the interest of efficient use of energy, health & safety and comfort of the occupants, it is imperative that all systems of ventilation should be considered in relation to the thermal characteristics of the building.

Mechanical Ventilation

There are three primary types of mechanical ventilation systems; 1) Mechanical extract/natural supply system, 2) Mechanical supply/natural extract system and 3) Combined mechanical supply/extract system or balanced ventilation system.

- 1) **Mechanical extract/natural supply** – or simply an “*extract system*” is designed to remove foul air, usually at high level, unless the fumes are heavier than air, when extraction would take place near floor level. This extraction creates an area of *negative pressure* causing the fresher replacement air to flow into the room through doors, windows, or through suitably spaced low level intake grilles.

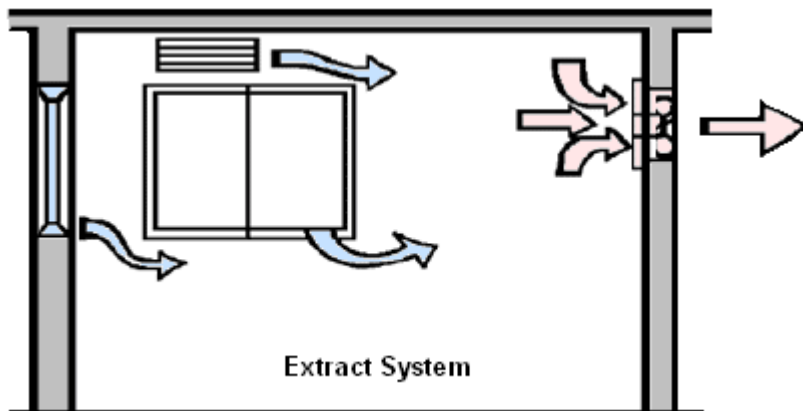

The simplest form of extract system comprises of one or more fans, usually of the propeller, axial flow or mixed flow type, installed in outside walls or in the roof. The discharge usually terminates in louvers or a cowl or a combination of both. Alternatively, the system may comprise a range of ductwork arranged for general extraction of the vitiated air or for extraction from localized sources of heat, moisture, odours, fumes and dust. Such ductwork may be connected to centrifugal or axial flow fans that discharge through the wall or roof, terminating in louvers or cowls or combination of both. The ductwork includes suitable extract points and dampers.

Exhaust ventilation system requires the replacement of exhausted air by way of make-up air. Replacement air can be supplied naturally by atmospheric pressure through open doors, windows, wall louvers, and adjacent spaces (acceptable), as well as through cracks in walls and windows, beneath doors, and through roof vents (unacceptable). Make-up air can also be provided through dedicated replacement air systems.

The exhaust system reduces the potential for wall and roof moisture problems but it shouldn't be used if filtered air is required in the space, as it would not be possible to filter all incoming air due to any uncontrolled leakage through cracks around doors and windows. This system can increase the potential for cold drafts, due to its depressurization effect, and, unless exhaust pickups are judiciously placed, tends to likewise provide poor air distribution.

An extract system can also be regarded as a palliative measure to meet the need for ventilation in particularly crowded rooms, offices or restricted areas in which local conditions are likely to prove objectionable as for example toilets, kitchens, plant rooms, workshops or laboratories or where there is a statutory requirement for exhaust ventilation.

- 2) **Mechanical supply/natural extract system** – This system is similar in form to the extract system but arranged to deliver fresh air into the enclosed space. Such a system necessitates provision for the discharge of vitiated air by natural means. Where there is a requirement for the enclosed space to be at a slightly higher (positive) pressure than its surroundings (to exclude dust or smoke, for example), the discharge may be through natural leakage paths or balanced pressure relief valves.

Careful location and speed control of intake fans and evenly distributed air supply diffusers are necessary to prevent draughty conditions. Ducted supply systems can provide better control of air movement and reasonable control of comfort conditions.

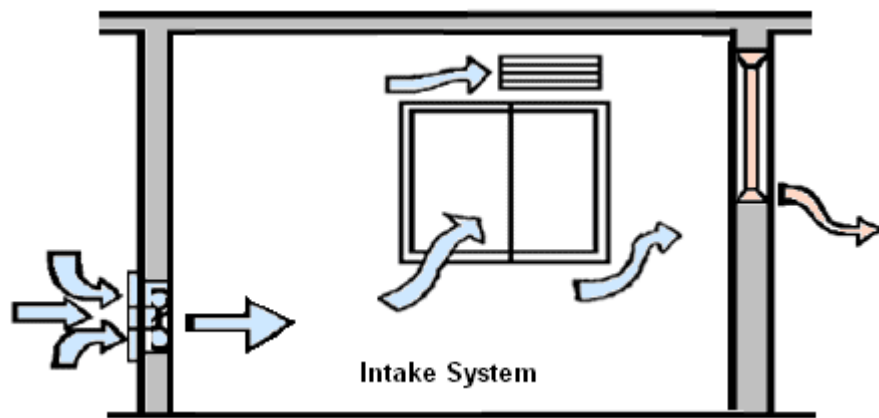

Mechanical supply system is essential where area is to be maintained at positive pressure and/or if the filtered air is required. This system tends to pressurize the building interior and lower the neutral pressure level*. By lowering the neutral pressure level, it reduces both the envelope area subject to infiltration and the inward pressures that drive infiltration airflow. However, the outward pressures and the envelope area subject to exfiltration are increased, which tends to increase the total exfiltration airflow.

The serious disadvantage of this approach is its increased potential for driving moisture-laden interior air into the wall and roof cavities, where it can condense and cause problems such as mould growth, rot, and peeling paint. This system should therefore only be used in a building with a very good air barrier. In colder regions of the country, the fresh air supply duct may require a duct heater to preheat the fresh air to prevent condensation on the furnace heat exchanger and cold drafts on the building's occupants. If the supply inlet is improperly located, sound can be transmitted into the building through the ventilation system.

* Neutral pressure level is a level in a building where the interior and exterior pressures are equal.

- 3) **Combined mechanical supply/extract system** – A combined system draws in fresh air from the exterior and discharge stale air from the interior in equal amounts. The balanced flow supply-exhaust ventilation system incorporates a central supply fan and a central exhaust fan. Balanced systems are only suitable for more airtight buildings where mechanical assistance is required to both supply and exhaust air; that is, where the building envelope is sufficiently tight to reduce air leakage to a level where it cannot provide adequate supply air by infiltration or exhaust flow by exfiltration.

When this type of system operates in a balanced condition, it has no net effect on the building's pressure distribution or the neutral pressure level, neither raising nor lowering it. However, conditions often result in a "balanced" system operating in an unbalanced way, as a net-exhaust or net supply system. For example, if the inlet screens of the supply fan become partially blocked, a net-exhaust situation may result. If the incoming air is very cold, it will warm up and expand as it enters the living space, resulting in a larger effective supply flow rate and a net-supply situation. Where the exhaust duct of an air-to-air heat exchanger becomes partially obstructed by frost build-up, the exhaust flow rate would be reduced and a net-supply situation would also result. Generally, exhaust systems are interlocked with a dedicated make-up air system.

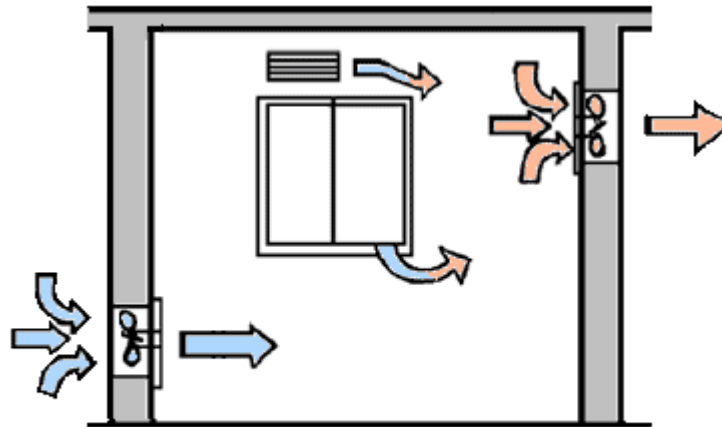

Combined System
(Forced Intake & Forced Exhaust)

Advantages of balanced combined systems

- 1) This type of system can provide high ventilation rates without large heating costs, if heat recovery ventilators are incorporated in the ventilation system.
- 2) Though the system does not affect the building's pressure balance, the larger ventilation rates possible with this type of system can reduce the indoor humidity levels and thus the potential for wall and roof moisture problems.
- 3) The larger and continuous ventilation rates can also help reduce the potential hazard from radon entry and chimney spillage, should they occur, by diluting the resulting indoor air contaminants.
- 4) This type of system provides very good air distribution, and is particularly suitable for automatic controls.
- 5) A balanced ventilation system has no additional need for a make-up air supply, so extra penetrations of the envelope are not necessary.

Disadvantages of balanced systems

- 1) The system is difficult to balance and may require a certified installer, further increasing the cost. Its maintenance requirements (inspection and cleaning) are extensive so operating costs can also be quite high.
- 2) This system is suitable primarily for new building construction; the envelopes of older buildings tend to be sufficiently leaky that natural infiltration and exfiltration would short-circuit the mechanical system. Its installation as a retrofit measure is usually not practical.

Choice of Mechanical System

Supply-only (intake-only) systems are more susceptible to condensation problems. The exfiltration of warm, humid air from these buildings occurs mainly through unintentional leakage paths in the building envelope. As a result, excess moisture can condense and be absorbed by the building materials at the lower temperatures encountered outside the vapor barrier. For this reason a supply-only system is not recommended.

The choice is essentially between a balanced system and an exhaust-only system. Normally, a balanced system is suited to houses with fireplaces or fuel-fired heating appliances, or where radon gas or other contaminants may collect in the building structure. Otherwise, because of its low initial cost an exhaust-only system is quite satisfactory unless the house is too tight?

Displacement Ventilation

Displacement ventilation, as illustrated in figure below is an alternative to conventional methods of dilution ventilation. Fresh air at, or slightly below, the desired room temperature is introduced at low level through diffusers to replace rising warm air. Because inlet air velocities are low, air disturbance and mixing in the room is small and the cool air displaces the warmer room air rather than diluting it. This system is claimed to be more efficient than dilution ventilation because contaminated air is displaced and removed rather than diluted.

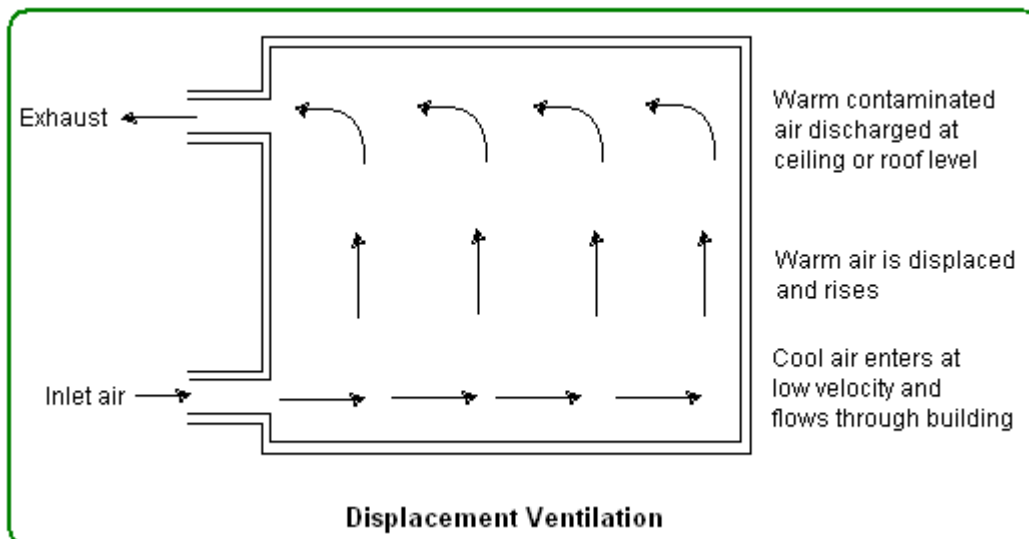

Displacement Ventilation Principle

The principle behind natural air displacement can be readily observed on a psychrometric chart. One pound of dry air at 80°F occupies 13.36 ft³ whereas 60°F air occupies 13.20 ft³. Inverting these quantities, one cubic foot of 80°F dry air weighs 0.0735 lb/ft³ and 60°F air weighs 0.0763 lb/ft³; the pressure exerted by the 60°F dry air is greater than the 80°F air. The magnitude of this air pressure difference can be illustrated by imagining a 10 ft X 10 ft air opening with still 60°F air pushing with 7.63 lbs, but the same 80°F air pushing with only 7.37 lbs. The cooler air flows in a stream to the warmer air in a natural attempt to equalize pressure. These conditions often exist in high bay industrial plants. Provided fans or open doors do not blow or mix the plant air, this still air seeks its own thermal level with 80°F air at the ceiling and 60°F air on the floor. Then when a 10 ft X 10 ft opening placed low near the floor let's tempered 60°F outdoor air slowly flow in, a standing pool of fresh air above the floor level will form. As heat from processes, people or heaters increase the air temperature, this heated air at say 80°F flows to the peak of the ceiling where a stack or roof opening vents this warm air outdoors. This natural draught system is powered solely by the heat added in the plant to increase the air temperature resulting in a lower air pressure at the ceiling than at the floor. These natural convection and air displacement systems work well when 1.) Cool air enters low at floor level where it stays, 2) Fresh air enters slowly to prevent mixing with plant air and 3) Heat from any source is added within the ventilated area.

Displacement Ventilation - Benefits

No Drafts- Air is typically supplied near the floor in the space at extremely low velocity, which results in no "throw" of air and subsequently little risk of "drafts".

Stratified Room Air- Supply air is purposely not uniformly mixed throughout the space. It is intentionally stratified vertically to provide a better quality of air in the occupied part of the facility. Supply air is delivered during occupancy at temperatures slightly lower than desired area temperature. The supply air moves horizontally across the floor until it naturally rises, driven by convective currents as it warms due to internal heat from the process, people, lights, computers, etc.

The space achieves superior flushing of room generated contaminants with an overall room ventilation rate of only 1.5 air changes per hour. This is less than half the ventilation rate that would be needed with a conventional mixing design, drastically lowering electrical energy use through reduced fan horsepower consumption due to less air movement.

Improved Effective Ventilation- Because of both people and process convective currents, in a high density or industrial application, there is a general upward flow of effluents above the occupied zone, as long as it is not greatly disturbed by fan forced air streams (as happens in conventional mixing distribution systems). Air rises from the lower level of the room around stationary processes due to the development of convective currents over power consuming machinery. This means that occupants located in the lower levels of a room will breathe air closer to supply air conditions, rather than the air being exhausted from the space at the ceiling level, improving ventilation effectiveness.

Individual Room VAV Not Needed- When there are few or no internal loads, such as an unoccupied area with the lights off and little solar gain, the area air will be slowly displaced upward by the air beneath it. In this case, the area will eventually be approximately the same temperature as the supplied air, which is only slightly cooler than the desired temperature, thus the need for individual area (variable air volume) VAV to prevent overcooling is virtually eliminated. "Demand control" of the total air supply to particular areas via temperature and Carbon Dioxide sensors is utilized to minimize energy use and fan horsepower during cold weather or low occupant density, and to supply higher rates of ventilation only when needed.

Reduced Cooling Capacity Needed - Thermal stratification also allows for some reduction of internal cooling requirements, because about 50% of the heat from the lights and other sources

located above the occupants does not reach the occupied zone and, in this design, is exhausted outdoors when not needed.

Less Fan Horsepower Needed- In this design approach, supply airflows needed to achieve adequate temperature control and provide adequate ventilation are often lower than conventional system. Thus, typically lower fan horsepower than conventional mixing type systems is needed.

Less Room Noise- Low velocity supply of air cannot be accomplished using conventional ceiling mounted mixing type diffusers, conventional heating ventilators (air make-up units), or non-ducted fan coils. With reduced total air flow quantities and low exit velocities, there is reduced noise when compared to mixing type systems because there is no need to forcefully mix air in the room and less total airflow is needed.

Less Inter-zone Pollutant Transport- The supply air "quality" to individual areas is also improved because, with a 100% outdoor air, the supply air is not already premixed with contaminated air which has been transported from other areas or zones of the building.

Displacement Ventilation – Limitations

Several practical difficulties exist for displacement ventilation systems, including:

- 1) In some cases, larger quantities of supply air may be required.
- 2) Because of the high supply air temperature, indoor humidity must be carefully controlled.
- 3) Displacement ventilation systems may not be appropriate when contaminants are heavier than air, or not associated with heat sources.
- 4) When very high loads exist, a displacement system will require uncomfortably cold supply air. Therefore, displacement ventilation may not be appropriate in extremely warm climates.
- 5) Performance of the displacement system is dependent upon ceiling height. Displacement ventilation may not be appropriate in spaces with low ceilings.

Natural Ventilation – Building Stack Effect

Many buildings use the principles of buoyancy or stack effect for air movement. When there is a difference in height between inlet openings situated low in the wall (or in floors) and outlets through roofs, and when outdoor air is cooler than indoor air, natural ventilation will occur through the stack effect of warm air rising and leaving through the higher openings. The warm air rises naturally, producing air movement through the building. As heated air escapes from upper levels of the building, indoor air moves from lower to upper floors, and replacement outdoor air is drawn into openings at the lower levels of buildings. Without mechanical ventilation (refer figure below), the outdoor air pressure is greater than the indoor pressure at the lower levels; the reverse is true at the upper levels.

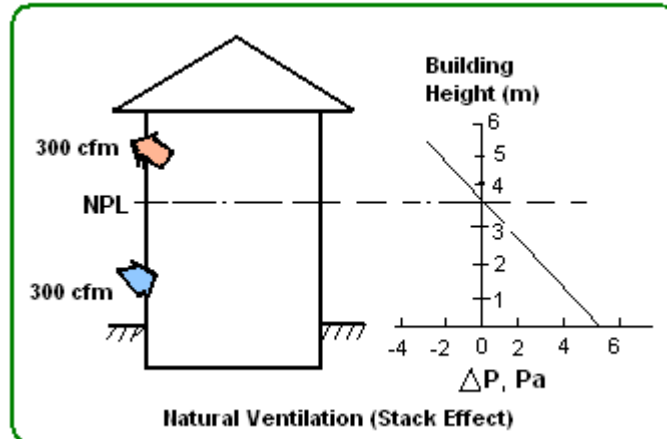

There is a level in a building where the interior and exterior pressures are equal and is called the neutral pressure level; below it, air infiltration occurs and above it, air exfiltration. *Measurements indicate that the total ventilation air supply rate increases as the outdoor air temperature decreases. It also increases with wind speed, but in cities with cold climates this effect is masked by the large indoor-outdoor temperature difference during the winter months.* Natural ventilation systems are most applicable when internal heat loads are high, and the building is tall enough to produce a significant stack effect.

The equation below is used in calculating ventilation (or infiltration) due to the stack effect.

$$Q = C \times A \times \frac{h \times (t_i - t_o)}{t_i}$$

In this equation:

Q = air flow (cfm)

C = constant of proportionality = 313 (This assumes a value of 65 percent of the maximum theoretical flow, due to limited effectiveness of actual openings. With less favorable conditions, due to indirect paths from openings to the stack, etc., the effectiveness drops to 50 percent, and C = 240.)

A = area of cross-section through stack or outlets in *sq ft*. (Note: Inlet area must be at least equal to this amount)

t_i = (higher) temperature inside (°F), within the height h

t_o = (lower) temperature outside (°F)

h = height difference between inlets and outlets.

The real advantages of a natural ventilation system are related to economics:

- (1) No expenses for ventilation equipment, electrical operation, and maintenance
- (2) No problems created by "brown-outs" or "black-outs," caused by storms or insufficient generation capabilities.

Stack effect in buildings can have negative effects on IAQ viz. the temperature differences, uncontrolled interior pressure differentials, reduced ventilation. Stack effect airflow can transport contaminants between floors by way of stairwells, elevator shafts, utility chases, or other openings. The building and system design should be able to counterbalance this effect.

Natural Ventilation – Wind Effect

Wind velocity and direction tend to be uncontrollable factors. Air flow due to wind around or over a building will create areas in which static pressure will be different than the pressure of the undisturbed air flow. Wind effects are transient, creating local areas of high pressure (on *the windward side*) and low pressure (*on the leeward side*) of buildings. On the remaining sides, static pressures will be positive or negative to lesser degrees depending upon the direction of air flow. The terrain surrounding the building can also create wind flow changes affecting building pressures. Surface roughness of the surrounding terrain (the size and location of surrounding buildings) influences the relationship of wind velocity to building height, which will affect the pressure patterns around the building's exterior, including the roof.

Depending on the leakage openings in the building exterior, wind can affect the pressure relationships within and between rooms. Even when the building as a whole is maintained under positive pressure, there is always some location (for example, the outdoor air intake) that is under negative pressure relative to the outdoors. Entry of contaminants may be intermittent, occurring only when the wind blows from the direction of the pollutant source. The interaction between pollutant pathways and intermittent or variable driving forces can lead to a single source causing IAQ complaints in areas of the building that are distant from each other and from the source.

In buildings employing natural ventilation systems, sidewall vents and continuous ridge vents for the full length of the building can be opened as far as desired to allow air to move through the building. To be ventilated satisfactorily, the building must have both sidewall and ridge vents. If a building has only side vents, then it can only be ventilated during periods of wind movement outside. Using ridge vents and side vents permits the building to be vented by both wind pressure and thermal gradients.

Thermal gradients generally are created within the building by heat loads inside the building, which in turn heat the air. As air is heated, it becomes lighter and rises through the ridge vents, with the makeup air coming from outside through the sidewall vents. If sidewall and ridge vents are properly sized, quite satisfactory ventilation rates can be achieved with some degree of temperature control. A natural ventilation system will not be as dependable or satisfactory as a mechanical ventilation system in terms of providing continuous, uniform ventilation.

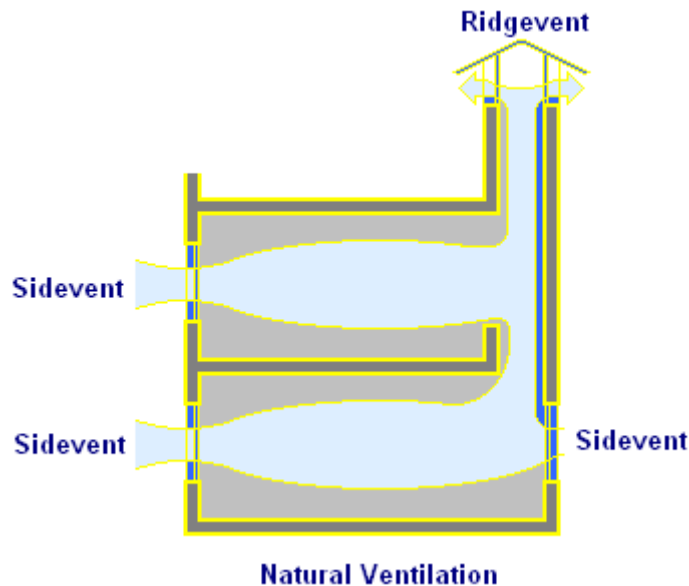

Natural ventilation and infiltration rates are governed by wind pressure on the building and by internal temperature differences which create an upward movement of warm, buoyant air. Natural ventilation will vary according to the weather conditions, and the ventilation rates are not always predictable or reliable. It may fail altogether in unfavorable conditions of wind and weather and thus can not be regarded as a suitable method for all applications.

Natural Ventilation Guidelines

Several general guidelines should be followed when designing for natural ventilation:

- 1) In hot, humid climates, maximize air velocities in the occupied zones for bodily cooling. In hot, arid climates, maximize air flow throughout the building for structural cooling, particularly at night when temperatures are low.
 - 2) Take advantage of topography, landscaping, and surrounding buildings to redirect airflow and give maximum exposure to breezes. Use vegetation to funnel breezes and avoid wind dams that reduce the driving pressure differential around the building. Site objects should not obstruct inlet openings.
 - 3) The stack effect requires vertical distances between openings to take advantage of the effect; the greater the vertical distance, the greater the ventilation.
 - 4) Openings with areas much larger than calculated are sometimes desirable when anticipating increased occupancy or very hot weather.
 - 5) Horizontal windows are generally better than square or vertical windows. They produce more airflow over a wider range of wind directions and are most beneficial in locations where prevailing wind patterns shift.
 - 6) Window openings should be accessible to and operable by occupants. Vertical air shafts or open staircases can be used to increase and take advantage of stack effects. However, enclosed staircases intended for evacuation during a fire should not be used for ventilation.
-

Section# 3 VENTILATION STRATEGIES FOR INDOOR AIR QUALITY

Indoor air quality (IAQ) refers to the quality of air within a space while ventilation is the method of diluting indoor air with air from outdoors. Ventilation is a key principle of improving IAQ. This approach can be effective either where buildings are under ventilated or where a specific contaminant source cannot be identified. Ventilation can be used to control indoor air contaminants by:

- 1) ***Diluting contaminants with outdoor air***
 - a. Increase the total quantity of supply air (including outdoor air)
 - b. Increase the proportion of outdoor air to total air
 - c. Improve air distribution
- 2) ***Isolating or removing contaminants by controlling air pressure relationships***
 - a. Install effective local exhaust at the location of the source
 - b. Avoid recirculation of air that contains contaminants
 - c. Locate occupants near supply diffusers and sources near exhaust registers
 - d. Use air-tightening techniques to maintain pressure differentials and eliminate pollutant pathways
 - e. Make sure that doors are closed where necessary to separate zones

Diluting contaminants with outdoor air

One of the most effective techniques for controlling contaminants particularly odours is to dilute them by increasing the flow of outdoor air. This can be accomplished by increasing the total supply airflow in the complaint area (e.g., opening supply diffusers, adjusting dampers) or at the air handling unit, (e.g., cleaning the filter on the supply fan). An alternative is to increase the proportion of outdoor air (e.g., adjusting the outdoor air intake damper, installing minimum stops on variable air volume (VAV) boxes so that they satisfy the outdoor air requirements of 20cfm per person in accordance to ASHRAE 62-1989).

Besides inadequate quantities of outdoor air most ventilation deficiencies appear to be linked to improper air distribution, which can also produce IAQ problems. Positions of inlet and extracts are most important and the care should be taken in their location. Care should be given to relatively nearby buildings and any contaminant discharges from those buildings. Inlet should not be positioned near to any flue outlets, dry cleaning or washing machine extraction outlets, kitchens, WC's etc. Diffusers should be properly selected, located, installed, and maintained so that supply air is evenly distributed and blends thoroughly with room air in the breathing zone. Short-circuiting occurs when clean supply air is drawn into the return air plenum before it has mixed with the dirtier room air and therefore fails to dilute contaminants. Mixing problems can be aggravated by temperature stratification. Stratification can occur, for example, in a space with high ceilings in which ceiling-mounted supply diffusers distribute heated air.

Note the side effects of increased ventilation:

1. Mitigation by increasing the circulation of outdoor air requires good outdoor air quality
2. Increased supply air at the problem location might mean less supply air in other areas
3. Increased total air in the system and increased outdoor air will both tend to increase energy consumption and may require increased equipment capacity
4. Any approach which affects airflow in the building can change pressure differences between rooms (or zones) and between indoors and outdoors, and might lead to increased infiltration of unconditioned outdoor air

5. Increasing air in a VAV system may overcool an area to the extent that terminal reheat units are needed

Note: Because of the high ventilation rates, the cost of conditioning outdoor air goes up significantly. Increasing a building's ventilation rate to speed up the removal of localized air-borne contaminants, even when energy use is not a concern, is not a solution to every problem. The most efficient strategy to improve air quality is to remove the contaminants at the source by local exhaust and then to rely on ventilation for the rest of the building. In the case of an identifiable contaminant source such as laboratory equipment, the exhaust from the source should be connected directly to the outside.

The designer may wish to give consideration to the conditioning of indoor air with odour removing equipment as an alternative to ventilation with outdoor air. This can take a number of forms, the one most widely applied to building air conditioning being adsorption by activated charcoal. This material is supplied in pellet form and applied as a bed through which the air stream passes. Performance can be varied through the design of the bed and the selection of the material. When the charcoal has adsorbed its full capacity of odourants, it is usually returned to the manufacturer for regeneration and replaced with fresh charcoal. The design of such a system would normally be based on established requirements for outdoor air. For example, if outdoor air requirements for odour control amount to 20 per cent of the air being circulated, processing all of the circulating indoor air with an odour controlling device that is 20 per cent effective would give comparable results. Outdoor air would, however, normally be required in sufficient quantity to maintain CO₂ levels within acceptable limits. In unusual situations where outdoor air is not available, such as in submarines, the CO₂ levels can be controlled by chemical treatment.

Isolating or removing contaminants by controlling air pressure relationships

A variety of airborne particles, such as dust, smoke, pollens and organisms are contained in the outdoor air and are brought indoors along with the ventilation air. Lot of contaminants are generated indoors by the activities of the occupants. *If the contaminant source has been identified, the "Isolation or Removal" can be more effective than "Dilution".* The term "ventilation efficiency" is used to describe the ability of the ventilation system to distribute supply air and remove internally generated pollutants. Researchers are currently studying ways to measure ventilation efficiency and interpret the results of those measurements.

Limiting the concentrations of contaminants could use any of the following techniques depending on the nature and severity of the contaminant:

- 1) The first technique for isolating odours and contaminants is to design and operate the HVAC system so that pressure relationships between rooms are controlled. This control is accomplished by adjusting the air quantities that are supplied to and removed from each room.

If more air is supplied to a room than is exhausted, the excess air leaks out of the space and the room is said to be under *positive pressure*. If less air is supplied than is exhausted, air is pulled into the space and the room is said to be under *negative pressure*.

Control of pressure relationships is critically important in mixed use buildings or buildings with special use areas. Lobbies and buildings in general are often designed to operate under positive pressure to prevent or minimize the infiltration of unconditioned air, with its potential to cause drafts and introduce dust, dirt, and thermal discomfort. Without proper operation and maintenance, these pressure differences are not likely to remain as originally designed.

- 2) The second technique is to use local exhaust systems (sometimes known as dedicated exhaust ventilation systems) to isolate and remove contaminants by maintaining negative

pressure in the area around the contaminant source. It also dilutes the contaminant by drawing cleaner air from surrounding areas into the exhaust airstream.

Local exhaust can be linked to the operation of a particular piece of equipment (such as a kitchen range) or used to treat an entire room (such as a smoking lounge or custodial closet). Air should be exhausted to the outdoors, not recirculated, from locations which produce significant odours and high concentrations of contaminants (such as copy rooms, bathrooms, kitchens, and beauty salons).

Spaces where local exhaust is used must be provided with make-up air and the local exhaust must function in coordination with the rest of the ventilation system. Under some circumstances, it may be acceptable to transfer conditioned air from relatively clean parts of a building to comparatively dirty areas and use it as make-up air for a local exhaust system. It may be necessary to add door or wall louvers in order to provide a path for the make-up air. (Make sure that this action does not violate fire codes.)

Such a transfer can achieve significant energy savings.

Correct identification of the pollutant source and installation of the local exhaust is critically important. For example, an improperly designed local exhaust can draw other contaminants through the occupied space and make the problem worse.

The physical layout of grilles and diffusers relative to room occupants and pollutant sources can be important. If supply diffusers are all at one end of a room and returns are all at the other end, the people located near the supplies may be provided with relatively clean air while those located near the returns breathe air that has already picked up contaminants from all the sources in the room that are not served by local exhaust.

- 3) The third technique is to use HVAC designs that introduce 100% outdoor air or that simply transfer air within the building. In hospitals for instance, where the control of infection from airborne sources is of special importance, ventilation is used to provide positive pressures in spaces containing patients prone to infection and negative pressures in spaces containing patients with highly communicable diseases. It is common practice also to circulate a high proportion of outdoor air, up to 100 per cent, in areas such as operating rooms. This results in a particularly high heating and cooling load for ventilation and leads designers to consider the economics of heat recovery devices in the exhaust air

Air Quality Control

Most indoor air pollution problems can be lessened or solved by increased air mixing by ventilation, by eliminating indoor sources and adjusting our activities, or by cleaning recirculated air. There is no sure or easy way to find the best mix. The foremost consideration in all buildings is to provide adequate transfer of oxygen and metabolic products.

In public places, like shopping malls, theaters, court rooms etc. the primary concern is the adequate ingress of outside air based on the occupancy levels. A person, when seated, usually inhales about 18 cu ft of air per hr. The exhaled air contains about 16 per cent O₂ and about 4 per cent CO₂. Thus, if only 18 cu ft per hr of fresh air were provided for each person in a continuously occupied space, the concentrations of CO₂ would exceed the permissible levels (ASHARE recommends the CO₂ levels should not exceed 1000ppm). Consumption of O₂ and production of CO₂ increase with activity, and ventilation requirements increase correspondingly. For people who are standing, the values are about 50 per cent higher than for those seated. Therefore supplies of outside air in excess of that required controlling the effect of respiration on O₂ and CO₂ levels plus for pressurization of the building are required. The building need to be positive pressurized so that uncontrolled infiltration is prevented.

In residential buildings, the main problem is humidity control. In reality, the water is produced during the two short mealtime and bathing peaks; instead of vanishing slowly, it migrates to cold spots where it condenses and remains stubbornly hidden in the form of moisture in the building materials, while most of the indoor air rapidly becomes normal or dry.

Condensation is a very serious problem if buildings designed for freely flowing air are suddenly retrofitted with insulation or vapor barriers to reduce heating costs. This condensation threatens the health of both the basic building structure and the occupants. The only adequate solution is to 'seal' the building and to provide intentional forced or natural ventilation at a rate adequate to mix air fully and remove excess moisture. Furthermore, buildings that rely on mechanical ventilation should not rely on uncontrolled infiltration, but should provide either natural cross-draught ventilation, or forced air circulation or both. Further, it is vital that such buildings have an appropriately placed air intake through which air may be admitted, either continually or in batches, as desired. In any case, natural ventilation should always be provided.

Natural forces exert an important influence on air movement between zones and between the building's interior and exterior. Both the stack effect and wind can overpower a building's mechanical system and disrupt air circulation and ventilation, especially if the building envelope is leaky.

Air - Cleaning

The third IAQ control strategy is to clean the air. Air cleaning is usually most effective when used in conjunction with either source control or ventilation; however, it may be the only approach when the source of pollution is outside of the building. Efficient air filtration prevents fouling of the system and is of special importance in urban areas, where damage is likely to be caused to decorations and fittings by discoloration owing to airborne dust particles. In order to obtain maximum filtration efficiency with the minimum capital and maintenance expenditure, the utmost care should be given to the location of the air intake in relation to the prevailing wind, the position of chimneys and the relative atmospheric dust concentration in the environs of the building.

Airborne dust and dirt can be generated within the building from the personnel and their movements as well as by machines, such as those used for card sorting. The degree of filtration necessary will depend on the use of the building or the conditioned space. The choice of filtration systems will depend on the degree of contamination of the air and on the cleanliness required. A combination of filter types may well give the best service and minimum operation costs. There are four technologies that remove contaminants from the air:

- 1) Particulate filtration
- 2) Electrostatic precipitation
- 3) Negative ion generation
- 4) Gas sorption

The first three approaches are designed to remove particulates, while the fourth is designed to remove gases.

*P*articulate filtration:

Particulate Filtration removes suspended liquid or solid materials whose size, shape and mass allow them to remain airborne for the air velocity conditions present. Filters are available in a range of efficiencies, with higher efficiency indicating removal of a greater proportion of particles and of smaller particles. Moving to medium efficiency pleated filters is advisable to improve IAQ and increase protection for equipment. However, the higher the efficiency of the filter, the more it will increase the pressure drop within the air distribution system and reduce total airflow (unless other adjustments are made to compensate). It is important to select an appropriate filter for the specific application and to make sure that the HVAC system will continue to perform as designed. Filters are rated by different standards (e.g., arrestance and dust spot) which measure different aspects of performance. The HEPA (high efficiency particulate air) filters are recommended for maintaining absolutely clean environments.

*E*lectrostatic Precipitation:

Electrostatic Precipitation is another type of particulate control. It uses the attraction of charged particles to oppositely charged surfaces to collect airborne particulates. In this process, the particles are charged by ionizing the air with an electric field. The charged particles are then collected by a strong electric field generated between oppositely-charged electrodes. This provides relatively high efficiency filtration of small respirable particles at low air pressure losses.

Electrostatic precipitators may be installed in air distribution equipment or in specific usage areas. As with other filters, they must be serviced regularly. Note, however, that electrostatic precipitators produce some ozone. Because ozone is harmful at elevated levels, EPA has set standards for ozone concentrations in outdoor air, and NIOSH and OSHA have established guidelines and standards, respectively, for ozone in indoor air. The amount of ozone emitted from electrostatic precipitators varies from model to model.

*N*egative ion generators:

Negative ion generators use static charges to remove particles from the indoor air. When the particles become charged, they are attracted to surfaces such as walls, floors, table tops, draperies, and occupants.

Some designs include collectors to attract the charged particles back to the unit.

Negative ion generators are not available for installation in ductwork, but are sold as portable or ceiling-mounted units. As with electrostatic precipitators, negative ion generators may produce ozone, either intentionally or as a by-product of use.

*G*as sorption:

Fumes and smells can be removed from air by chemical processes such as “gas sorption” which control compounds that behave as gases rather than as particles (e.g., gaseous contaminants such as formaldehyde, sulfur dioxide, ozone, and oxides of nitrogen). These may be essential when the ambient air is heavily polluted, although it may be possible to limit operating costs by minimizing the thermal loads caused by the introduction of large quantities of fresh air. The decision to use odour removing equipment will normally be made on economic grounds, but the arguments in its favor will be increased by the currently rising cost of energy. Once this equipment is installed, it should be regularly serviced to ensure satisfactory performance.

Gas sorption involves one or more of the following processes with the sorption material (e.g., activated carbon, chemically treated active clays):

- 1) A chemical reaction between the pollutant and the sorbent,
- 2) A binding of the pollutant and the sorbent, or
- 3) Diffusion of the contaminant from areas of higher concentration to areas of lower concentration

Gas sorption units are installed as part of the air distribution system. Each type of sorption material performs differently with different gases. Gas sorption is not effective for removing carbon monoxide. There are no standards for rating the performance of gaseous air cleaners, making the design and evaluation of such systems problematic.

Operating expenses of these units can be quite high, and the units may not be effective if there is a strong source nearby.

*U*se carbon dioxide sensors for demand control ventilation:

Carbon dioxide-based demand- controlled ventilation systems vary the ventilation rate based on carbon dioxide (CO₂) levels in the building. For spaces with extreme variations in occupancy, such as banquet halls or meeting rooms, carbon dioxide sensors located in each zone adjacent to the room thermostat or in the common return air automatically control the amount of outside air. The controls are set such that the CO₂ level do not exceed ASHRAE permissible levels of 1000ppm.

The equation for calculating outdoor quantities using carbon dioxide measurements is:

$$\text{Outdoor air (in percent)} = \frac{C_s - C_r}{C_o - C_r} \times 100$$

Where:

C_s= ppm of carbon dioxide in the mixed air (if measured at an air handler) or in supply air (if measured in a room)

C_r= ppm of carbon dioxide in the return air

C_o= ppm of carbon dioxide in the outdoor air

The auto-controller ensures that the increased ventilation is supplied only when required or needed for higher occupancies. This benefit in the energy cost savings because of reduced cooling and heating of outdoor air during reduced occupancy rates.

Building Pressurization

A common cause of IAQ problems in hot and humid climates is negative building pressure. Negative building pressure can occur through the improper design and operation of the exhaust systems in a building. Operating exhaust fans without the outside air being compensated through the air-handling system will result in negative pressure in the building. Negative pressure in a building allows uncontrolled infiltration through doors and the exterior envelope of the building. This will typically make the building feel drafty and difficult to heat in cold climates and muggy or musty in hot and humid climates since unconditioned outside air is being constantly introduced into the building through uncontrolled infiltration.

The basic principle of air movement from areas of relatively higher pressure to areas of relatively lower pressure can produce many patterns of contaminant distribution, including:

1. Local circulation in the room containing the pollutant source
2. Air movement into adjacent spaces that are under lower pressure (*Note: even if two rooms are both under positive pressure compared to the outdoors, one room is usually at a lower pressure than the other*)
3. Recirculation of air within the zone containing the pollutant source or in adjacent zones where return systems overlap
4. Movement from lower to upper levels of the building
5. Air movement into the building through either infiltration of outdoor air or re-entry of exhaust air

The HVAC system is generally the predominant pathway and driving force for air movement and distribution of contaminants. The large buildings are divided into multiple zones each having independent HVAC system or control. But still the contaminants can flow from one zone to another because of building obstructions and people movement. For example, as air moves from supply registers or diffusers to return air grilles, it is diverted or obstructed by partitions, walls, and furnishings, and redirected by openings that provide pathways for air movement. On a localized basis, the movement of people has a major impact on the movement of pollutants. Some of the pathways change as doors and windows open and close. It is useful to think of the entire building — the rooms and the connections (e.g., chases, corridors, stairways, elevator

shafts) between them — as part of the air distribution system. Air moves from areas of higher pressure to areas of lower pressure through any available openings. A small crack or hole can admit significant amounts of air if the pressure differentials are high enough (which may be very difficult to assess). Theoretically, one-inch water gauge pressure is equivalent to wind velocity of 4005 feet per minute (~45 miles/hr). The amount of expected leakage can be calculated from the following:

$$\text{Leakage in CFM} = \sqrt{\text{Room Pressure in wg}} \times 4005$$

Assuming 0.05" wg,

$$\begin{aligned} \text{Leakage} &= 0.223 \times 4005 \\ &= 895 \text{ feet per minute} \end{aligned}$$

With a total of ½ square feet opening size

$$\text{Leakage} = \frac{1}{2} \times 895 = \sim 450 \text{ CFM}$$

With higher pressurization the leakage velocity, leakage rates and the processing costs shall also increase. The room pressure should be limited to 0.03" to 0.05" (~0.75 to 1.25mm) as pressure above this not only entails high capital costs but also increases the operating costs.

Positive pressurization can be maintained only if the sealing integrity of the building is maintained. The building should be air tight for low air leakage performance. There are areas within the facility that require negative exhausts such as toilets, pantry, laboratory or battery room but these are controlled ventilation areas having fixed amount of exhaust. Uncontrolled leakage areas in the building are door undercuts; pass through, walls, ceilings and duct joints etc; that should be restricted as far as possible. Remember a slogan;

“Build tight –ventilate right”

The building shall be optimally pressurized to achieve low capital costs, overall energy conservation and treatment costs on filtration.

Section# 4 ESTIMATING VENTILATION RATES

To satisfy the ventilation requirement a mechanical ventilation system should be capable of delivering the design ventilation rate. The ventilation rate can be estimated using various techniques:

Air Quality Method

ASHRAE Standard 62-1999: "Ventilation for Acceptable Indoor Air Quality" is a nationally accepted standard that provides acceptable ventilation rates per person and is related to the occupational density and activity within the space. The table below provide snapshot of the outside air recommendations and the procedure is as follows:

- 1) Determine the number of people occupying the respective building spaces; $People = \frac{Occupancy}{1000} \times Floor\ Area\ (ft^2)$
- 2) Find the Ventilation Rates for Acceptable Indoor Air Quality; $Q = (cfm\ outdoor\ air\ person) \times (number\ of\ people)$

Q is the desired flow rate. The "cfm outdoor air person" is ASHRAE's recommended design outdoor airflow rates. (Refer table below)

Alternatively ventilation rate can be estimated directly based on the sq-ft area;

$Q = (cfm/sq\ ft\ floor\ area) \times (sq\ ft\ floor\ area)$

The "cfm/sq-ft floor area" is ASHRAE's recommended design values.

Ventilation Recommendations

<i>Application</i>		<i>Occupancy (people/1000ft²)</i>	<i>Cfm/person</i>	<i>Cfm/ft²</i>
Food and Beverage Service	Dining rooms	70	20	
	Cafeteria, fast food	100	20	
	Bars, cocktail lounges	100	30	
	Kitchen (cooking)	20	15	
Offices	Office space	7	20	
	Reception areas	60	15	
	Conference rooms	50	20	
Public Spaces	Smoking lounge	70	60	
	Elevators			1.00
Retail stores, Showrooms	Basement & Street	30		0.30
	Upper floors	20		0.20
	Malls and arcades	20		0.20
	Smoking lounges	70	60	
	Beauty shops	25	25	
	Hardware stores	8	15	
Sports and Amusements	Spectator areas	150	15	
	Games rooms	70	25	

Application		Occupancy (people/1000ft²)	Cfm/person	Cfm/ft²
	Playing rooms	30	20	
	Ballrooms and discos	100	25	
Theaters	Lobbies	150	20	
	Auditorium	150	15	
Education	Classroom	50	15	
	Music rooms	50	15	
	Libraries	20	15	
	Auditoriums	150	15	
Hotels, Motels Resorts, Dormitories	Bedrooms			30cfm/room
	Living rooms			30cfm/room
	Lobbies	30	15	
	Conference rooms	50	20	
	Assembly rooms	120	15	
	Dry cleaning, laundry	30	30	
	Gambling casinos	120	30	
Health Care Facilities	Hospital operating rooms	20	30	
	Hospital patient rooms	10	25	
	Laboratories	30	20	
	Medical procedure rooms	20	15	
	Pharmacies	20	15	
	Physical therapy	20	15	

Source: ASHRAE Standard 62-1989 "Ventilation for acceptable indoor air quality"

The ventilation rates specified by ASHRAE effectively dilutes the carbon dioxide and other contaminants created by respiration and other activities; it supplies adequate oxygen to the occupants; and it removes contaminants from the space. The ventilation rates greater than by ASHARE criteria are sometime required controlling odours and where cooling is not provided to offset heat gains.

Air Change Method

The most common method used to calculate ventilation air requirements is based on complete changes of air in a structure or room in a given time period. To determine the airflow required to adequately ventilate an area,

- 1) Calculate the Room Volume to be ventilated Width x Length x Height = ft³ (cubic feet).
- 2) Calculate the Air Volume requirement by multiplying the Room Volume by the Air Change Rate per hour = ft³/h.

The equation below is used in calculating cubic feet per minute of ventilation air.

$$Q = \frac{(ACH) \times (room\ volume)}{60\ min/h} = cu\ ft/min$$

In this equation,

Q is the volume flow rate of air being calculated, and ACH is the number of air changes per hour expected, based on the type of construction (tight, medium, or loose) under the given conditions.

Alternatively divide the room volume (in cubic ft.) by the appropriate "Minutes per Air Change" as shown in the chart below. **Note that Air Changes per Hour = 60/ minutes per air change*

Additional considerations when determining the number of air changes are:

- 1) Local code requirements on air changes
- 2) Specific use of the space
- 3) The type of climate in the area

In the most severe conditions select the lower number (in the series shown) to change the air more frequently. For moderate conditions, select the mid range. For less severe conditions in cool climates, the higher number will provide adequate ventilation.

Suggested Air Changes for Good Ventilation

Type of Space	Minutes per Air Change	Type of Space	Minutes per Air Change
Assembly Halls	3 - 10	Heat Treat Rooms	1 - 2
Attic	2 - 4	Hospital	4 - 6
Auditoriums	4 - 15	Kitchens	2 - 4
Bakeries	1 - 3	Laboratory	2 - 5
Banks	3 - 10	Laundries	2 - 5
Banquet Halls	3 - 4	Locker Rooms	2 - 5
Bar/Lounge	2 - 5	Lodge Rooms	3 - 5
Barns	10 - 15	Machine Shops	3 - 5
Beauty Parlors	2 - 5	Meeting Rooms	4 - 6
Boiler Rooms	2 - 5	Mill (General)	3 - 8
Bowling Alleys	2 - 8	Mills (Paper)	2 - 3

Type of Space	Minutes per Air Change	Type of Space	Minutes per Air Change
Cafeteria	3 - 5	Mills (Textile)	5 - 15
Church	4 - 10	Office	2 - 8
Schools/Classroom	4 - 6	Packing Houses	2 - 5
Club Room	3 - 7	Plating Rooms	1 - 5
Corridors/Halls	6 - 20	Printing Plants	3 - 8
Dairies, Creameries	2 - 5	Projection Room	1 - 2
Dance Hall	3 - 7	Recreation Rooms	2 - 8
Dining Rooms	3 - 6	Residences	3 - 6
Dormitories	5 - 8	Restaurants/Dining Rooms	3 - 7
Dry Cleaners	2 - 5	Restrooms	3 - 6
Engine Rooms	1 - 2	Retail Stores	3 - 8
Factories (Light)	5 - 10	Ship Holds	8 - 10
Factories (Heavy)	2 - 6	Shops (General)	3 - 10
Forge Shops	1 - 3	Theaters	3 - 8
Foundries	1 - 4	Transfer Room	1 - 5
Garages	2 - 10	Transformer Rooms	1 - 5
Generator Room	2 - 5	Tunnels	6 - 10
Glass Plants	1 - 2	Turbine Rooms	2 - 6
Gymnasiums	3 - 8	Warehouses	3 - 10

Heat Removal Method

When the temperature of a space is higher than the ambient outdoor temperature, general ventilation may be utilized to provide "free cooling". In air-conditioned buildings, winter heat loss (and summer heat gain in closed, cooled buildings) occurs when fresh outdoor air enters a building to replace stale indoor air. This heat exchange must be calculated when sizing heating or cooling equipment or when estimating energy use per season. Air exchange increases a building's thermal load in three ways.

- 1) First, the incoming air must be heated or cooled from the outdoor air temperature to the indoor air temperature.
- 2) Second, air exchange increases a building's moisture content, which means humid outdoor air must be dehumidified.
- 3) Third, air exchange can increase a building's thermal load by decreasing the performance of the envelope insulation system.

The calculation of the heat lost (or gained) by the introduction of outdoor air into spaces is:

$$q = 1.08 * V * \Delta t$$

Where:

q = sensible heat exchange due to ventilation (Btu/h)

V = volume flow rate, in cubic feet per minute (cfm) of outdoor air introduced

ΔT = temperature difference between outdoor and indoor air °F

1.08 = A constant derived from the density of air at 0.075 lb/cu ft under average conditions, multiplied by the specific heat of air (heat required to raise 1 lb of air 1°F), which is 0.24 Btu/lb°F, and by 60 min/h. The units of this constant are Btu min/cu ft °F h.

For example, if the total heat gain is say 82500 BTU/Hr, the outside shade temperature 70 °F and the maximum inside temperature required 85°F then the volume of air required is:

$$82500 / [1.1 * (85 - 70)] = 5000 \text{ CFM}$$

Note that a small reduction in the temperature difference makes a considerable increase in the volume of air required. For instance, if in the example above the temperature difference is reduced by say 5°F, i.e., required inside temperature 80°F, then the volume of air required would be increased to:

$$82500 / [1.1 * (80 - 70)] = 7500 \text{ CFM}$$

Section# 5 **INDUSTRIAL VENTILATION**

Industrial ventilation is a method of controlling worker exposure to airborne toxic chemicals or flammable vapors by exhausting contaminated air away from the work area and replacing it with clean air. It is one alternative to control employee exposure to air contaminants in the workplace. Other alternatives include process changes, work practice changes, substitution with less toxic chemicals, or elimination of the use of toxic chemicals. Industrial ventilation is typically used to remove welding fumes, solvent vapors, oil mists or dusts from a work location and exhaust these contaminants outdoors. The requirement for ventilation in industrial situations is normally connected with the process requirements.

Regulatory Information

Various regulations require that, as far as practicable, employers must reduce the risks from hazardous substances. The regulation also requires that control measures such as ventilation be used in preference to personal protective equipment. There are various regulations and standards pertaining to adequacy of ventilation. Foremost are those recommended by the Air Movement and Control Association (AMCA), the American Society of Heating, Refrigerating, and Air-Conditioning Engineers (ASHRAE), the American National Standards Institute (ANSI), the Sheet Metal and Air Conditioning Contractors National Association (SMACNA), the National Fire Protection Association (NFPA), and the American Conference of Governmental Industrial Hygienists (ACGIH). AMCA is a trade association that has developed standards and testing procedures for fans.

- 1) ASHRAE is a society of heating and air conditioning engineers that has produced, through consensus, a number of standards related to indoor air quality, filter performance and testing, and HVAC systems.
- 2) ANSI has produced several important standards on ventilation, including ventilation for paint spray booths, grinding exhaust hoods, and open-surface tank exhausts. Four ANSI standards were adopted by OSHA in 1971 and are codified in 29 CFR 1910.94; these standards continue to be important as guides to design. ANSI has recently published a new standard for laboratory ventilation (ANSI Z9.5).
- 3) SMACNA is an association representing sheet metal contractors and suppliers. It sets standards for ducts and duct installation.
- 4) NFPA has produced a number of recommendations (which become requirements when adopted by local fire agencies), e.g., NFPA 45 lists a number of ventilation requirements for laboratory fume hood use.
- 5) The ACGIH has published widely used guidelines for industrial ventilation.
- 6) OSHA REGULATIONS Ventilation criteria or standards are included in OSHA regulatory codes for job- or task-specific worker protection. In addition, many OSHA health standards include ventilation requirements. The four standards in 29 CFR 1910.94 deal with local exhaust systems, and OSHA's construction standards (29 CFR 1926) contain ventilation standards for welding. OSHA's compliance policy regarding violation of ventilation standards is set forth in the Field Inspection Reference Manual.

The ventilation system should comply with the requirements laid down in the current statutory legislation or any revisions currently in force, and consideration should also be given to any relevant insurance company requirements.

Exhaust Ventilation System

Exhaust ventilation systems are used to remove airborne contaminants consisting of dusts, fumes, mists, fibers, vapors, and gases that can create an unsafe, unhealthy, or undesirable atmosphere. Replacement air, which is usually filtered and/or conditioned, provides air to the

work space, which replaces exhausted air. A complete industrial ventilation program includes replacement air systems that provide a total volumetric flow rate equal to the total exhaust rate. If insufficient replacement air is provided, the pressure of the building will be negative relative to local atmospheric pressure. Negative pressure allows air to infiltrate through open doors, window cracks, and combustion equipment vents.

There are two types of exhaust systems:

- 1) General Exhaust or Dilution system in which an entire work space is exhausted without considering specific operations.
- 2) Local Exhaust, in which the contaminant is controlled at its source.

General Exhaust (or Dilution) Ventilation System

The terms “general exhaust” and “dilution ventilation” are often used interchangeably.

This type of exhaust refers to dilution of contaminated air in a general area, room, or building and is usually accomplished with the use of large exhaust fans in the walls or roof of a building or room. Opening doors or windows can be used as dilution ventilation, but this is not always a reliable method since air movement is not controlled. Cooling fans (floor fans) are also sometimes used as a method of ventilation, but these fans usually just blow the contaminant around the work area without effectively controlling it. In general, dilution ventilation is not as satisfactory for health hazard control as is local exhaust. In some cases, dilution ventilation must be used because the operation or process prohibits local exhaust. Circumstances may be found in which dilution ventilation provides an adequate amount of control more economically than a local exhaust system. Economical considerations should not be based entirely upon the first cost of the system because dilution ventilation frequently exhausts large volumes of heat from a building and can easily be a troublesome factor.

General exhaust ventilation (dilution ventilation) is appropriate when:

- 1) Emission sources contain materials of relatively low hazard. (The degree of hazard is related to toxicity, dose rate, and individual susceptibility);
- 2) Emission sources are primarily vapors or gases, or small, respirable-size aerosols (those not likely to settle);
- 3) Emissions occur uniformly;
- 4) Emissions are widely dispersed;
- 5) Moderate climatic conditions prevail;
- 6) Heat is to be removed from the space by flushing it with outside air;
- 7) Concentrations of vapors are to be reduced in an enclosure; and
- 8) Portable or mobile emission sources are to be controlled.
- 9) Local exhaust ventilating is appropriate when:
 - 10) Emission sources contain materials of relatively high hazard;
 - 11) Emitted materials are primarily larger-diameter particulates (likely to settle);
 - 12) Emissions vary over time;
 - 13) Emission sources consist of point sources;
 - 14) Employees work in the immediate vicinity of the emission source;
 - 15) The plant is located in a severe climate; and
 - 16) Minimizing air turnover is necessary.

Dilution ventilation is most often used to advantage to control the vapors from organic liquids such as the less toxic solvents. To successfully apply the principles of dilution to such a problem, factual data are needed on the rate of vapor generation or on the rate of liquid evaporation. To determine the correct volume flow rate for dilution (Q_d), it is necessary to estimate the evaporation rate of the contaminant (q_d) according to the following equation:

$$q_d = \frac{(387)(lbs)}{(MW)(min)(d)}$$

Where

q_d = Evaporation rate in ACFM

387 = Volume in cubic feet formed by the evaporation of one lb-mole of a substance, e.g. a solvent

MW = Molecular weight of the emitted material

lbs = Pounds of evaporated material

Min = time of evaporation in minutes

d = density correction factor

The appropriate dilution volume flow rate for toxics is:

$$Q_d = \frac{(q_d)(K_m)(10^6)}{C_a}$$

Where

Q_d = Volume flow rate of air, in ACFM

q_d = Evaporation rate in ACFM

K_m = Mixing factor to account for poor or random mixing (note $K_m = 2$ to 5 ; $K_m = 2$ is optimum)

C_a = Accessible airborne concentration of the material (typically half of the PEL)

Dilution Ventilation - Limiting Factors

The use of dilution ventilation has four limiting factors:

- 1) The quantity of contaminant generated must not be too great or the air volume necessary for dilution will be impractical.
- 2) Workers must be far enough away from contaminant evolution, or evolution of contaminant must be in sufficiently low concentrations so workers will not have an exposure in excess of the established Threshold Limit Values (TLVs).
- 3) The toxicity of the contaminant must be low.
- 4) The evolution of contaminants must be reasonably uniform.

Dilution ventilation is seldom applied to fumes and dusts because the high toxicities often encountered require too great a quantity of dilution air, velocity and rate of evolution are usually very high, and data on the amount of fumes and dust production are very difficult, if not impossible, to obtain.

Effectiveness of Dilution Ventilation

Dilution ventilation can be more effective if the exhaust fan is located close to exposed workers and the makeup air is located behind the worker so that contaminated air is drawn away from the worker's breathing zone. In cases where the source of contamination is widely scattered or is from a mobile source, like carbon monoxide from a forklift, large wall or roof exhaust fans can be effective. Makeup air to replace the air exhausted is necessary for the best control. Simple openings in walls or doors can be sources of makeup air, or a second fan can draw makeup air into the building or room. However, makeup air may require heating in the winter resulting in increased heating bills. In practice, replacement depends on mixing efficiency. Some basic principles to be applied to a dilution ventilation system are as follows:

- 1) From factual data, select the amount of air required for satisfactory dilution of the contaminant.
- 2) Locate the exhaust openings near the sources of contaminant if possible, in order to obtain the benefit of spot ventilation.
- 3) For dilution methods to be effective, the exhaust outlet and air supply must be located so that all the air used in the ventilation passes through the zone of contamination.
- 4) Replace exhausted air by a make-up air system. Make-up air should be heated during cold weather. Dilution ventilation systems usually handle large quantities of air by means of propeller fans. Make-up air usually must be provided if the ventilation is to be adequate and the system is to operate satisfactorily.
- 5) The general air movements in the room caused by suction at the exhaust opening should keep the contaminated air between the operator and the exhaust opening, and not draw contaminants across the operator.
- 6) A combined supply and exhaust system is preferred with a slight excess of exhaust if there are adjoining occupied spaces, and a slight excess of supply if there are no such spaces.
- 7) Avoid re-entrance of the exhausted air by discharging the exhaust high above the roof line, or by assuring that no window, outside air intakes, or other such openings are near the exhaust discharge.

Local Exhaust Ventilation Systems

Local exhaust ventilation captures air contaminants at their source.

Local exhaust ventilation unlike dilution ventilation is designed to capture an emitted contaminant at or near its source, before the contaminant has a chance to disperse into the workplace air. Local exhaust ventilation operates on the principle that air moves from an area of high pressure to an area of low pressure and the difference in pressure is created by a fan that draws or sucks air through the ventilation system. A local exhaust system operates in the same manner as a household vacuum cleaner.

Local exhaust ventilation is needed when employees are exposed to high toxicity chemicals, when large amounts of dusts or welding fumes are generated, or when increased heating costs from ventilation in cold weather are a concern. It is necessary when:

- 1) the contaminant is toxic or corrosive (such as lead fumes, acid mist, solvent vapor)
- 2) contaminant levels are high
- 3) contaminants must be filtered out before release into the air
- 4) The process gives off heat.

It is most effective because:

- 1) It minimizes employee exposure to contaminants
- 2) The volume of exhaust air is much less than for general ventilation

- 3) The contaminant can be collected for disposal or recovery
 - 4) Equipment in the workplace is protected from heat and corrosive substances
 - 5) Employees may not have to wear respiratory protection.
-

System Configuration

A typical local exhaust ventilation system is composed of five parts:

- 1) A fan that moves the air through the system and discharges (blows) it outdoors,
- 2) A "hood" or opening that captures the contaminant at the source,
- 3) Ducts that transport the airborne chemicals through the system,
- 4) An air cleaning device (not always required) that removes the contaminant from the moving air in the system,
- 5) An exhaust stack through which the contaminated air is discharged.

The figure below illustrates the basic components of local exhaust system.

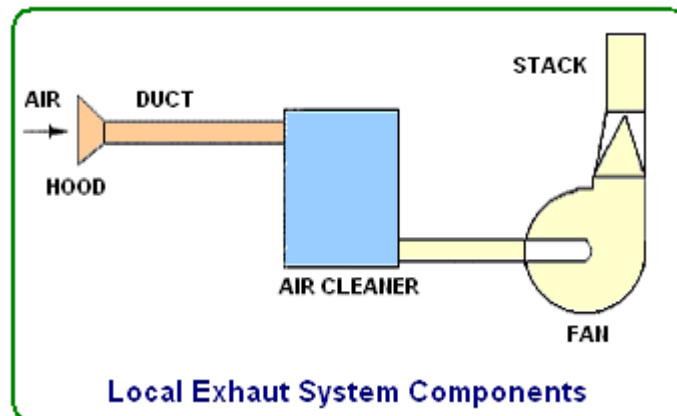

As with dilution ventilation, makeup air must be provided to replace the air exhausted in order for the system to operate properly.

Fan

The fan is the heart of the system, creating movement of air to shift the contaminants. These must provide enough air pressure difference ("suction") to capture contaminants at the source, draw them through the hood, carry them through the ducting and exhaust them outdoors.

To choose the proper fan for a ventilation system, the following information must be known:

- 1) Air volume to be moved;
- 2) Fan static pressure;
- 3) Type and concentration of contaminants in the air (because this affects the fan type and materials of construction); and
- 4) The importance of noise as a limiting factor.

Once this information is available, the type of fan best suited for the system can be chosen. Many different fans are available, although they all fall into one of two classes: axial flow fans and centrifugal fans. Axial or propeller fans are most commonly used for dilution ventilation or

for cooling. They can move large amounts of air if there is little resistance, but are not suited for local exhaust ventilation because they do not provide enough suction to draw air through the system.

Centrifugal fans can operate at against a high resistance and are typically used in local exhaust ventilation systems. There are several types of centrifugal fans. The rugged radial blade centrifugal fans are the best type for exhausting heavy amounts of dust because they are less likely to become clogged or abraded by the dust.

Fans carrying corrosive materials must be lined with or constructed of corrosive-resistant materials. Fans carrying combustible materials must be explosion proof and have wheels and housings constructed of nonferrous or non-sparking materials. Motors mounted in the air stream must also be explosion proof. When flammable, combustible, or other harmful materials or substances are conveyed, fans must be placed outside of buildings.

Hoods

The hood captures, contains, or receives contaminants generated at an emission source. Hoods come in a variety of designs. The one you choose should enclose or be located as close as possible to the contaminant source and be matched to the particular process. The hood should be designed so it captures contaminants as they are given off. Examples of different types of hoods are illustrated in figure below.

- 1) Enclosure - contains contaminants released inside the hood.
- 2) Receiving hood - catches contaminants that rise or are thrown into it.
- 3) Capturing hood - reaches out to draw in contaminants
- 4) Downdraft hood

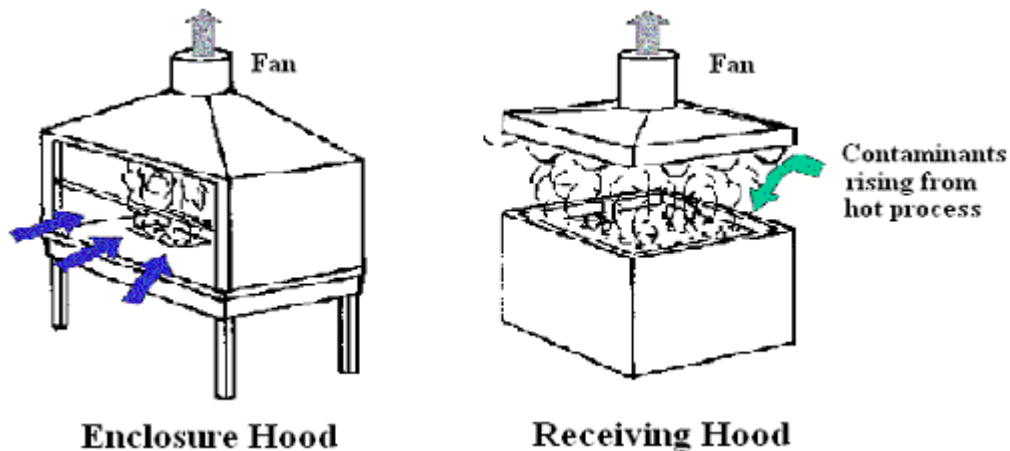

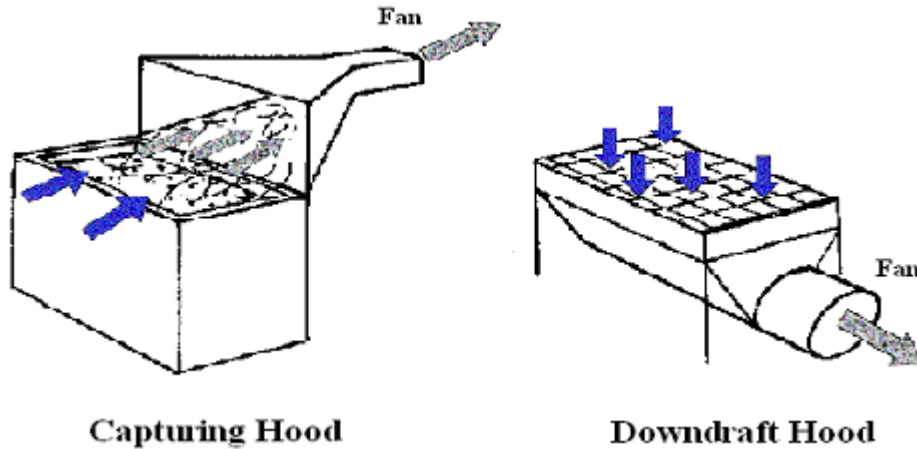

The hoods are made of various materials, such as epoxy-coated steel, stainless steel, fiberglass, epoxy resin, polypropylene, and PVC. The front of the hood is called the face and is usually equipped with a movable, transparent sash. Enclosing hoods provide the best control but they are often not feasible because they would interfere with the work being done by the employee. In those cases, a capture exhaust hood can only be located near the source of the contaminant. These types of hoods "reach out" to capture the contaminant much like a vacuum cleaner sucking dirt off a floor.

Hoods: Basic Design Principles

The basic goal of industrial hood design is to enclose the industrial process as completely as possible, allowing only enough access for the user and for maintenance. When complete enclosure is not practical, the hood should be designed to accommodate the work process while remaining as closed as possible. The hood should be located close to the work process to minimize air volume. The access openings of well-designed and built hoods minimum are located away from the natural path of contaminant travel to eliminate or minimize air motion around the work process. The hood should also be positioned so contaminants are removed away from the user.

Velocity

Proper hood design includes components to provide necessary air velocity. Velocity is the speed of the air through the various exhaust components, given in feet per minute (fpm). Capture velocity is the air velocity at any point in front of the hood or at the hood opening necessary to overcome opposing air currents and to capture contaminated air at that point by causing it to flow into the hood.

Generally Accepted Face Velocites

Hood Class	Velocity fpm
Class A	125-150
Class B	100
Class C	80

The air velocity at the hood opening and inside the hood must be sufficient to capture and carry the air contaminants. The hood should enclose the source of contaminant as much as possible or be placed as close to the source as possible.

The conventional hood has a movable, vertical or combination horizontal and vertical sash. In the full open vertical position of the sash, the free area of the hood face is generally about 10 to 13 square feet. The volume of air exhausted is calculated using: $Q = A \times V$, where Q is air volume in cfm; A is face area in square feet; and V is face velocity in fpm. Therefore, a Class B laboratory fume hood with a minimum average face velocity of 100 fpm would exhaust 1,000 to 1,300 cfm of air through the hood.

Velocity Range

Lower velocities are acceptable when minimal room air currents are present. Lower velocities are also acceptable when there are other conditions that are favorable to capture contaminants or when the contaminants are of low toxicity. Additionally, lower velocities are used when the work process is intermittent or there is a low production of contaminants and the hood is large with a large air volume.

Higher velocity ranges are needed for high velocity room air currents or for other conditions that are unfavorable to the capture of contaminants. Higher velocities are required when contaminants have a high toxicity or when the work process has a high production of contaminants or the hood is small.

The exhaust system design must also account for duct velocity, face velocity, slot velocity, and plenum velocity. Duct velocity is the air velocity through the duct. Minimum duct velocity is the minimum air velocity required to move particles or contaminants through the duct. Face velocity is the air velocity at the hood opening. Slot velocity is the air velocity through the openings in a slotted hood, and plenum velocity is the air velocity in the plenum.

Minimum Duct Velocities

Contaminant	Velocity Range (fpm)
Fine, light dust	2000-2500
Dry dust	2500-3500
Industrial dust such as sawdust	3500-4000
Heavy dust such as metal dust	4000-4500
Moist, heavy dust such as moist cement dust	4500-5000

Volume

Air volume through the fume hood and exhaust system is measured in cubic feet per minute (cfm). The volume of exhaust air necessary to safely remove contaminants from the work process must be adequate but should not be excessive. A high volume of air may increase velocities to an extent that the effectiveness and safety of the hood is compromised. Increased air volume increases horsepower requirements by as much as the cube of the volume. Therefore, the hood should be as close to the work as possible, *as the volume of the exhaust air varies with the square of the distance from the process*. For example, a work process requiring 1,000 cfm of exhaust air would actually need 4,000 cfm of exhaust air if the process were twice the distance from the hood.

System Pressure

The pressure inside a local exhaust system is slightly negative compared to the pressure outside the system and is measured in units called "inches of water". This negative pressure

varies through the system and is usually measured to determine how well the system is functioning.

The hood converts duct static pressure to velocity pressure the hood's ability to convert static pressure to velocity pressure is given by the coefficient of entry (C_e), as follows:

$$C_e = (VP/SP_h)^{0.5} = [1/(1+K)]^{0.5}$$

Where

K = Loss factor

VP = Velocity pressure in duct

SP_h = Absolute static pressure about 5 duct diameters down the duct from the hood

Design Points to Note

- 1) The hood should be designed to achieve good air distribution into the hood openings so that all the air drawn into the hood helps to control contaminants.
- 2) High capture velocity with low air volume is desirable. To minimize air-flow requirements, the operation should be enclosed as much as possible, either with a ventilated enclosure, side baffles, or curtains. This helps both to contain the material and to minimize the effect of room air currents.
- 3) Reducing the amount of contaminants generated or released from the process reduces ventilation requirements.
- 4) The purpose of most ventilation systems is to prevent worker inhalation of contaminants. For this reason, the hood should be located so that contaminants are not drawn through the worker's breathing zone. This is especially important where workers lean over an operation such as an open-surface tank or welding bench.
- 5) Hoods must meet the design criteria in the ACGIH *Industrial Ventilation Manual* or applicable OSHA standards. Most hood design recommendations account for cross-drafts that interfere with hood operation. Strong cross-drafts can easily reduce a hood's effectiveness by 75%. Standard hood designs may not be adequate to contain highly toxic materials.

Rules of Thumb for Hoods Application

1) Distance between Source and the Hood

The distance between the face of the hood and source must be short to effectively capture the contaminant. A hood moved from two inches away from a source to four inches away from a source will require four times the amount of air volume through the system to provide the same degree of capture. Adding a flange to the edges of the capturing hood provides more efficient capture of contaminants. Place hood as close to the source of the contaminant as possible. *The required air volume varies with the square of the distance to the source.*

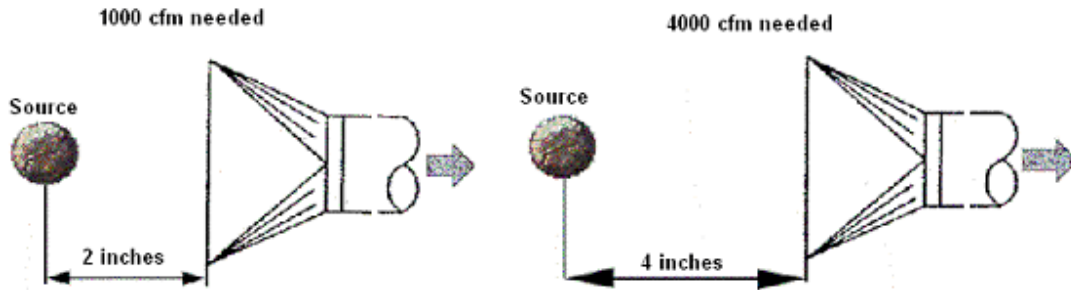

Flow Rate as distance from Hood

2) **Relationship of Capture Velocity (V_c) to Duct Velocity (V_d)**

Hood placement must be close to the emission source to be effective. Maximum distance from the emission source should not exceed 1.5 duct diameters.

The approximate relationship of capture velocity (V_c) to duct velocity (V_d) for a simple plain or narrow flanged hood is illustrated in figure below. For example, if an emission source is one duct diameter in front of the hood and the duct velocity (V_d) = 3,000 feet per minute (fpm), then the expected capture velocity (V_c) is 300 fpm. At two duct diameters from the hood opening, capture velocity decreases by a factor of 10 to 30 fpm.

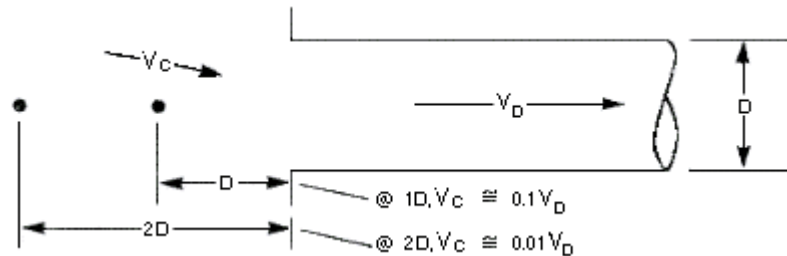

3) **Maximum Capture distance should not be more than 1.5 times the duct diameter.**

Figure below shows a rule of thumb that can be used with simple capture hoods. If the duct diameter (D) is 6 inches, then the maximum distance of the emission source from the hood should not exceed 9 in. Similarly, the minimum capture velocity should not be less than 50 fpm.

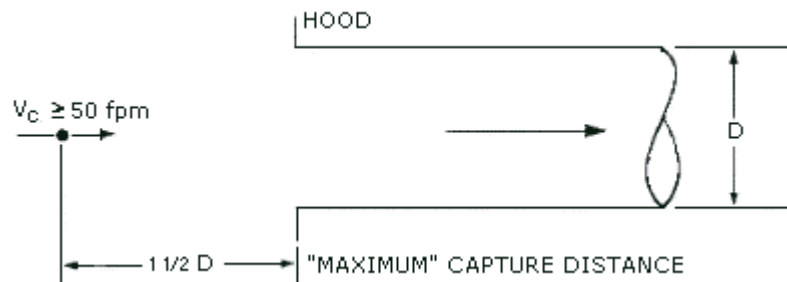

4) Figure below provides guidance for determining an **effective flange width (W)**.

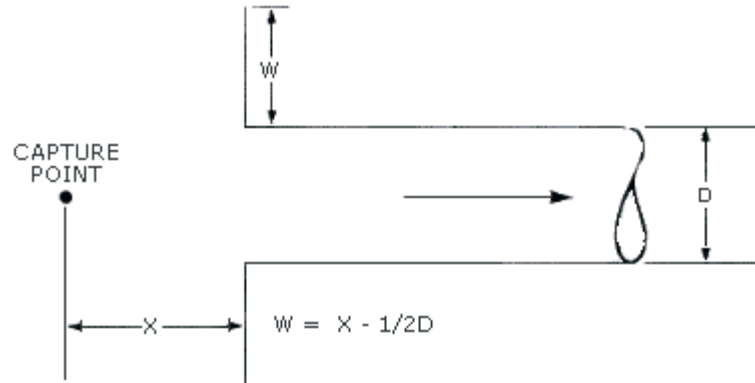

Ductwork

Ducts carry the contaminants from their source to an outlet point. To do this effectively, the types of effluents or waste materials that will be in the hood and exhaust ducts and discharged into the atmosphere must be known when designing ductwork. Note the key design features as below:

- 1) Air velocity in the ducting must be high enough to prevent contaminants settling in the system, but not so high that it causes vibration and noise problems. Air flows turbulently through ducts at between 2,000-6,000 feet per minute (fpm).
- 2) Smooth, round ducts are recommended for local exhaust systems. Dust can get trapped in the corners of square ducts, and air turbulence is higher inside them, reducing air velocity.
- 3) There should be as little resistance in the form of turbulence or friction as possible. Friction losses vary according to ductwork type, length of duct, velocity of air, duct area, density of air, and duct diameter. Sharp bends or tees should be avoided in ducts as well as abrupt changes in diameter. Also, smaller diameter duct will have greater friction than larger diameter ductwork.
- 4) Ducting should be straight at least two duct diameters before entering the fan to maintain smooth airflow into the fan. Duct connections must also be as tight as possible to prevent a reduction in air velocity at the hood because of leaks at joints.
- 5) The ambient temperature of the space in which the ductwork is installed is also important because temperature affects the condensation of the vapors in the exhaust system, and condensation can cause corrosion of ductwork metals. Consideration must also be given to the length and arrangement of duct runs. The longer the duct the longer shall be the exposure to effluents and, therefore, more condensation. When condensation is likely, sloped ductwork and condensate drains should be provided. Condensate drains that may accumulate hazardous materials must be given special consideration.
- 6) Exhaust ductwork should be of adequate strength and construction to accommodate the type of waste material flowing through the duct and the air pressures generated by the fan system.
- 7) Ducts can be made of galvanized metal, fiberglass, plastic, and concrete. Proper design does not use flexible duct connectors in hidden spaces or with corrosive materials.

System Effect Loss

System effect loss, which occurs at the fan, can be avoided if the necessary ductwork is in place. Use of the six-and-three rule ensures better design by providing for a minimum loss at

six diameters of straight duct at the fan inlet and a minimum loss at three diameters of straight duct at the fan outlet (refer figure below).

An illustration of the “Six and Three Rule”

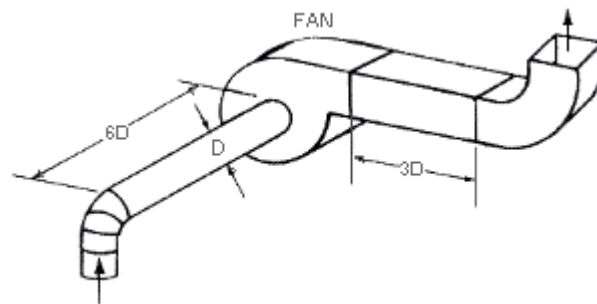

System effect loss is significant if any elbows are connected to the fan at inlet or outlet. For each $2\frac{1}{2}$ diameters of straight duct between the fan inlet and any elbow, CFM loss will be 20%.

Air Cleaners

Air cleaning devices on ventilation systems are sometimes necessary to capture large amounts of dust. In some instances, they may be required by air pollution regulations. The type of air cleaner depends on the type of contaminant being removed, its concentration in the air, the amount of contaminant that must be removed, and other factors.

The types of air cleaning equipment in common use are settling chambers, cyclones, filter panels of various types, electrostatic precipitators, carbon filters, gas scrubbers and air sterilizers (for bacteria). Dust filters are the most common type of air cleaners found in industry. The selection of equipment suitable for a particular job depends on the degree of fineness of the dust (particle size), the required efficiency of collection (the percentage of the finer particles to be removed), and the amount of dust to be collected. Local air pollution regulations dictate the type of air cleaner required. The cost and extra resistance that these air cleaners add to an exhaust ventilation system must be considered in the design. Regular maintenance of air cleaners increases their efficiency and minimizes worker exposure.

Exhaust Stacks

Stacks disperse exhaust air into the ambient environment. It must be high enough to avoid gas re-entering the workplace and make sure contaminant levels on the ground are within clean air standards. The amount of re-entrainment depends on exhaust volume, wind speed and direction, temperature, location of intakes and exhausts, etc. Exhaust stacks also need to be designed and located properly for the most efficient operation of a local exhaust system. A common mistake is to locate them too close to building fresh air intakes. When installing stacks:

- 1) Locate stacks on the highest roof of the building so that exhausts are discharged above the building envelope and not on the side of the building. Provide ample stack height (a minimum of 10 ft above adjacent rooflines or air intakes);
- 2) Place stack downwind of air intakes;
- 3) Provide a stack velocity of a minimum of 1.4 times the wind velocity;
- 4) Air velocity out of the stack should be at least 3000 feet per minute to overcome the effects of downdrafts from wind blowing over the building.
- 5) Place the stack as far from the intake as possible to prevent re-circulation of contaminants (50 ft is recommended);
- 6) Stacks work best when they are tall, usually at least 10 feet above the roof line; and

- 7) Rain caps should not be used on exhaust stacks, as they tend to deflect air downward, increasing the chances that contaminated air would lay on the roof and circulate into the building. Additionally, rain caps have high friction losses and may actually provide less rain protection than a properly designed stack head.

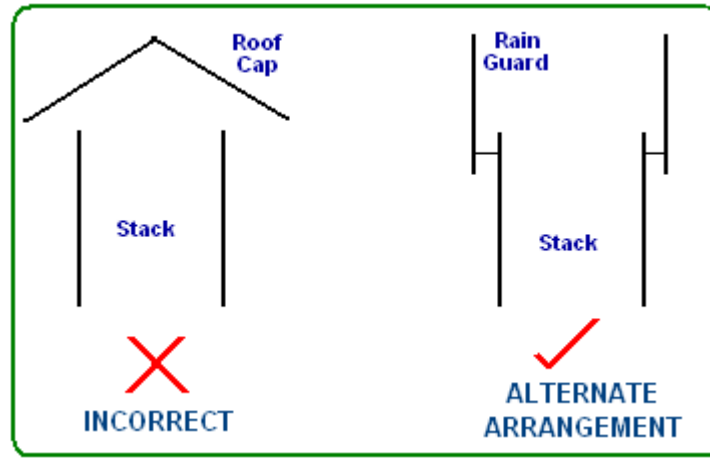

Type of Local Exhaust System

Local exhaust systems can be classified as: (1) Constant Air Volume or (2) Variable Air Volume, based on the method of system operation and control. Each of these classifications can be further broken down into individual or central systems based on the arrangement of the major system components such as the fans, plenums, or duct mains and branches.

Constant Air Volume Systems

This type of system exhausts a fixed quantity of air from each safety cabinet, fume hood, or room module. Constant air volume systems will handle the same exhaust air quantity for any condition. For this reason, the capacities of the exhaust air and supply air systems will limit the total number of fume hoods and room modules to be installed. This type of system is flexible with respect to location of hoods but may incur high ownership and operating costs because of the large air volumes handled. These high costs may impose a limitation on the total number of hoods or modules that can be installed in the building.

Constant air volume systems are highly stable in operation and simple to balance.

In most installations, there is no need for continuous adjustment of air balance during normal operation.

Variable Air Volume Systems

Variable air volume systems can shut down inactive fume hoods and room modules.

This capability results in an economic system that reduces the air flow during periods when some of the hoods and room modules are not in use, and the exhaust air system is operated at less than full capacity. More freedom in the installation of the hoods and room modules is possible since the total number of units that may be connected does not entirely depend on the capacity of the exhaust system.

Variable air volume systems are not as stable in operation as constant air volume systems are. They are also more difficult to balance and control. Sensitive instrumentation and controls are required, which result in high initial and maintenance costs. Reliability in a corrosive atmosphere is highly questionable.

For some applications, the use of balancing dampers in exhaust air ducts is prohibited by codes. One problem associated with the variable air volume system is the regulation of the total simultaneous operating usage to match design usage factors. If the collective area of operating hood openings at any one time exceeds design opening diversity values, the proper face velocity requirements will not be achieved and personnel could be endangered. Visual and audible alarms should be equipped on hoods to warn workers of unsafe air flows.

Individual Exhaust Systems

Individual exhaust air systems use a separate exhaust air fan, exhaust connection, and discharge duct for each hood or module. These are used in selective applications requiring special exhaust filtration, special duct or fan construction for corrosive elements, or to exhaust fumes that have very hazardous elements.

Each fume hood has its own exhaust connection, duct, and fan, which does not directly affect the operation of any other area of the building, which permits selective operation of individual hoods and modules by starting or stopping the fan motor. Normally, the exhaust fan is always on and is interlocked electrically with the supply fan so that when the exhaust goes off the supply fan does too.

Although more fans are used than for central systems, the overall space requirements are usually less for individual systems because of the small, direct duct connection. Individual fume hood exhaust systems are inexpensive for small systems having only a few fans. However, if the system is large, the initial investment and the operating costs are high because of the greater number of fans, roof penetrations, and controls, and the more extensive ductwork and wiring that must be installed and maintained. The maintenance costs are also high but since each hood has its own ductwork, exhausted air from fume hoods does not mix and shutdowns for repairs or maintenance are localized.

The shutdown of individual exhaust air systems will upset the proper directional air flow and may cause potentially hazardous contaminants and odours to flow into the corridor and adjacent rooms. If this type of system is used, precautions to reverse air flow (such as air locks) should be provided.

Central Exhaust Systems

Facilities that use many fume hoods usually have a central exhaust system. Central exhaust air systems consist of a common suction plenum, a primary fan, a standby fan and branch connections to multiple exhaust terminals. Grouping exhaust devices by type, proximity, fire pressurization, or contamination zones minimizes cost.

Compared to an individual system of equivalent size, a central exhaust system requires a smaller initial investment and has a lower operating cost. The air is more diluted before being exhausted into the atmosphere. The central system has a standby fan for safety and provides greater flexibility for future expansion.

Central systems are more difficult to balance and require frequent periodic re-balancing to ensure proper airflow. Air balancing of central systems is more difficult when there are various types of exhaust devices installed on common duct runs.

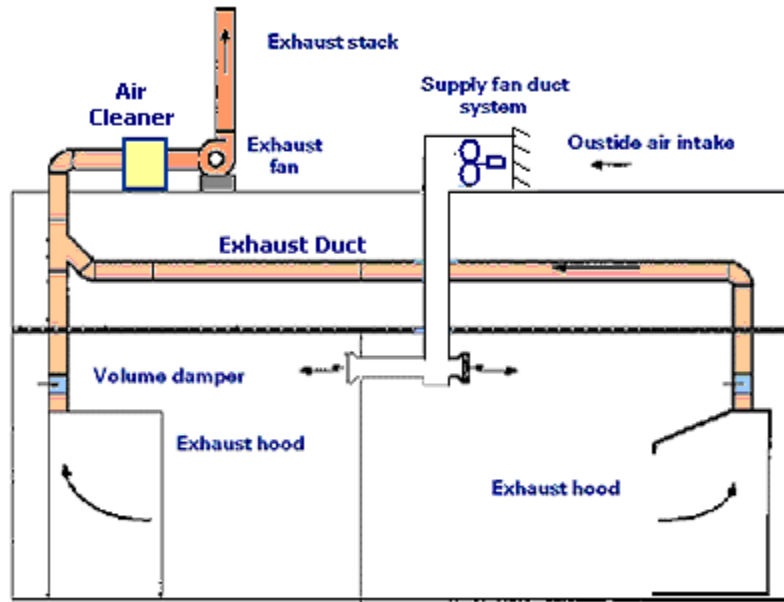

Central Exhaust System

Section# 6 General System Design Considerations

- 1) Aim for full cross-ventilation of the space. The cross-ventilation is based on the natural tendency of the air to move from high to low pressures. The warm air moves naturally, producing air displacement through the building (natural ventilation).
- 2) Air replacement should be provided at the minimum rate of 1 sq-ft of free area per 600 CFM of air moved. Air replacement grilles usually have a free area of approximately 60%. For example - a 12" square grille will have a face area of $12 \times 12 = 144$ sq-ft, therefore 60% of 144 sq-ft = 86.4 sq-ft free area. This means that this grille will provide air replacement for the rate of $86.4 \times 600 = 51,840$ CFM. Use sufficient correctly sized grilles to keep supply and extract air velocities between 300 feet per minute and 600 feet per minute, if possible.
- 3) Locate units at high level, and inlet grilles usually just above head level to avoid uncomfortable draughts to the occupants. The natural upward convection currents and the secondary entrained air movements caused by the "jet" of air, more or less horizontal, from the inlet grilles will give sufficient gentle air turbulence around breathing level to maintain a feeling of freshness.
- 4) Locate intake and exhaust fans to make use of prevailing winds. Locate fans and intake ventilators for maximum sweeping effect over the working area. If filters are used on gravity intake, size intake ventilator to keep intake losses below 1/8 in-wg.
- 5) In larger industrial buildings, temperature differences encourage the upward flow of air. If the building contains the hot processes, dusts and fumes are carried rapidly up to be discharged through roof ventilators or fans. Always extract from as high as possible to prevent the collection of heated air under the roof or ceiling from extending downwards to near breathing level. Fans at or near the ridge in such cases are ideal, with air replacement from side windows above the head level. This method assists the natural tendency for warmer air to rise and the quicker this 'fug' is removed from high level the better will be the conditions at breathing level.
- 6) When considering air replacement, the location of suitable air intake points is as important as the location of the extract units. Note that with ventilation alone, the temperature inside a room cannot be reduced to the outside shade temperature - it will always be a few degrees above. *However, it is worth considering pulling the replacement air from the "cold" side of the building - the north facing (north of the equator).*
- 7) Air movement from inlets is directional, maintaining high velocities for a considerable distance, whereas air movement into extract openings is not directional, so air velocities close to extract openings are generally low. The fast moving airstream from the inlet therefore has more influence on air movement in the room or workplace, entraining air and causing turbulence over a wide area. This principle sometimes permit inlet and extract ports to be positioned close to each other over a limited area.
- 8) Supply and extract points external to the building should be a minimum of 6 feet apart. Figure below indicates the required separations and clearances for intake and exhaust vent openings. Vents should be at least 1 meter (40 inches) from any corner of the building to minimize wind effects. Intakes should be at least 450 mm (18 inches) and exhaust vents at least 200 mm (8 inches) above the ground to avoid snow blockage and contamination by ground care products such as herbicides. Intakes and exhaust vents should be separated vertically or horizontally by at least 1800 mm (6 feet) to minimize the potential for cross contamination.

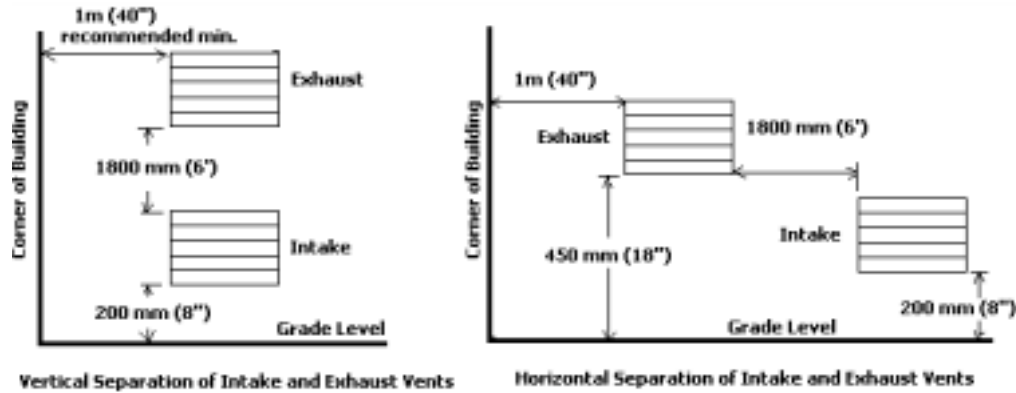

- 9) These vents should be located where they are shielded from the direct impact of the wind, and away from sources of potential contamination, such as vehicle parking, loading bays, and fuel or chemical storage. In addition, intake vents can conduct noise and so should be located away from sound sources, such as mechanical equipment, fans, air-conditioning condensing units and cooling towers.
- 10) Avoid fans blowing opposite each other, when necessary; separate by at least 6 fan diameters.
- 11) Exhaust ducts should be installed with backdraft dampers to prevent them from functioning as intakes when they are not powered. All intake and exhaust openings should be provided with hoods and non-corroding screens to protect them from weather and entry by insects and small animals.
- 12) Proper air distribution and circulation is very important. In spite of an adequate supply of ventilation air, there may be inadequate supply for some rooms because of poor distribution. Continuous positive air movement is highly desirable since it equalizes temperature, carbon dioxide, and humidity levels within the building. Though the optimum air velocity has never been thoroughly investigated, it is suggested that a minimum velocity of 40 FPM should be provided. Below this level, air flow is unpredictable, and mixing throughout will not be achieved.
- 13) The level of air motion at the worker is important. At fixed work positions with light activity, the velocity should not exceed 200 fpm for continuous exposure. With high work levels and intermittent exposures, velocities of 400 to 800 fpm may be used. When high-velocity air is used, it is important to avoid the undesirable effects of hot air convection and disturbance of local exhaust ventilation systems. Table below lists some acceptable air motion rates.

Exposure	Air Velocity, fpm
Continuous	
Air-conditioned space	50 to 75
Fixed workstation, general ventilation, or spot cooling	
Sitting	75 to 125
Standing	100 to 200
Intermittent, spot cooling, or relief stations	
Light heat loads and activity	1000 to 2000
Moderate heat loads and activity	2000 to 3000
High heat loads and activity	3000 to 4000

Acceptable Air Motion at the Worker

- 14) Use Class B insulated motors where ambient temperatures are expected to be high for air-over motor conditions.
- 15) If air moving over motors contains hazardous chemicals or particles, use explosion-proof motors mounted in or out of the airstream, depending on job requirements. For hazardous atmosphere applications use fans of non-sparking construction.
- 16) If the room is very wide, say over 80 ft it may be necessary to extract centrally and bring in replacement air along each side.
- 17) Design System for Zero Temperature Stratification- Temperature stratification in simple word means vertical temperature difference between feet and head. It is a common problem caused by convection, the tendency of light- warm air to rise and heavier-cooler air to sink. If air is not properly mixed by the ventilation system, the temperature near the ceiling can be several degrees warmer than at floor level.
- 18) Absence of Drafts: Large vertical surfaces can also produce a significant flow of naturally-convecting air, producing complaints of draftiness. As a rule of thumb, horizontal temperature differences should not exceed 10°C and vertical temperature differences should not exceed 5°C. To avoid draft, ASHRAE suggests that air speeds should be below 40 FPM with ventilation systems that create 30-60% turbulence intensity. Use ceiling diffusers with 45° or 90° angles over 10° angles because 10° angles can cause draught at the head; Circulated air should be no more than 2°F different from the ambient space temperature.
- 19) To provide effective general ventilation for heat relief by either natural or mechanical supply, the air must be delivered in the work zones (no more than 10 ft above the floor) with an appreciable air velocity. A sufficient exhaust volume is necessary to remove the heat liberated in the space. Local relief systems may require supplementary supply air for heat removal.
- 20) Modifications to a room or workplace, particularly the installation of internal partitions, may affect the circulation of air and reduce the effectiveness of ventilation. Where part of a workplace is blocked or partitioned off, for example, to create internal offices, it is important to ensure that the ventilation system extends to all areas and that suitably sized air grilles are incorporated in the partition walls or doors if necessary. In some cases, supplementary fans may be required to promote air movement and prevent localized stagnation.

Fire and Safety Considerations

The installation of mechanical installation system may affect the fire risk within the building, both as regards structural protection and means of escape in case of fire and may influence any necessary fire venting or fire fighting considerations.

The extent and detail of statutory control and other specialist interests may vary considerably according to the design, use, occupation and location of the building, and the type of system of mechanical ventilation proposed. It is particularly important that the appropriate authority be fully consulted at an early stage.

The degree of control and the requirements imposed vary according the circumstance of the case, depending on whether the control concerns means of escape (e.g. clearance for smoke in the event of fire), structural fire precautions (e.g. maintenance of structural fire separations), health of occupants, conservation of energy or any combination of these. Full details may have to be approved by the local authority in such cases as:

- 1) Buildings controlled from the point of view of the means of escape where recirculation of air is involved and/or where pressurized staircases are contemplated as part of the smoke control arrangements
- 2) Places of public gathering/entertainment
- 3) Flats and apartments where mechanical ventilation is necessary to lobby and corridors as part of the smoke control arrangements
- 4) Large garages and car parks, hotels, parts of buildings used for trades or processes involving a special risk, departmental stores and similar shop risks in large buildings
- 5) Certain areas of the building require separate and independent mechanical ventilation systems. These include: lavatories, toilets, garages, kitchens and car parks, staircases for control of smoke, boiler chambers, and areas containing oil immersed electric plant or hazardous materials.

Locker Room, Toilet, and Shower Space Ventilation

The ventilation of locker rooms, toilets, and shower spaces is important in removing odour and in reducing humidity. Legal minimum requirements should be consulted when designing these facilities. In toilets recommended rates of exhaust ventilation are 10 ACH or 2cfm /sq-ft whichever is higher. Supply air may be introduced through door or wall grilles. Toilets must be maintained at negative pressure.

When control of workroom contaminants is inadequate, the total exposure to employees can be reduced by making sure that the level of contamination in the locker rooms, lunchrooms, and break rooms is minimized by pressurizing these areas with excess supply air.

When mechanical ventilation is used, the supply system should have supply fixtures such as wall grilles, ceiling diffusers, or supply plenums to distribute the air adequately throughout the area. In locker rooms, the exhaust should be taken primarily from the toilet and shower spaces, as needed, and the remainder from the lockers and the room ceiling. Table below provides a guide for ventilation of these spaces.

Ventilation for Locker Rooms, Toilets and Shower Spaces

Description	Ventilation Rate
<p>Lockers Room</p> <ol style="list-style-type: none"> 1) Coat hanging or clean change room for non-laboring employees with clean work clothes 2) Change room for laboring employees with wet or sweaty clothes 3) Change room for heavy laborers or workers assigned to working and cleaning where clothes will be wet or pick up odours. 	<p>1cfm /sq-ft</p> <p>2cfm /sq-ft; 7cfm exhausted from each locker</p> <p>3cfm /sq-ft; 10cfm exhausted from each locker</p>
<p>Toilet Spaces</p>	<p>2cfm /sq-ft; at least 25cfm per toilet facility; 200cfm minimum</p>
<p>Shower Spaces</p>	<p>2cfm /sq-ft; at least 50cfm per shower head; 200cfm</p>

	per shower head; 200cfm minimum
--	---------------------------------

Process Ventilation

- 1) Collect fumes and heat as near the source of generation as possible.
- 2) Make all runs of ducts as short and direct as possible.
- 3) Keep duct velocity as low as practical considering capture for fumes or particles being collected.
- 4) When turns are required in the duct system use long radius elbows to keep the resistance to a minimum (preferably 2 duct diameters).
- 5) After calculating duct resistance, select the fan having reserve capacity beyond the static pressure determined.
- 6) Use same rationale regarding intake ventilators and motors as in General Ventilation guidelines above.
- 7) Install the exhaust fan at a location to eliminate any recirculation into other parts of the plant.
- 8) When hoods are used, they should be sufficient to collect all contaminating fumes or particles created by the process.

Kitchen Ventilation

Extract systems from kitchen equipment should be separate from any other and the extracted air should not be recirculated. The following design guidelines should be noted:

Hoods and Ducts

- 1) Duct velocity should be between 1500 and 4000 fpm
- 2) Hood velocities (not less than 50 fpm over face area between hood and cooking surface)
- 3) Extend hood beyond cook surface 0.4 x distance between hood and cooking surface
- 4) Canopy, ducting and lagging should be made from non-combustible material.

Filters

- 1) Select filter velocity between 100 - 400 fpm
- 2) Determine number of filters required from a manufacturer's data (usually 2 cfm exhaust for each sq. in. of filter area maximum)
- 3) Install at 45 - 60° to horizontal, never horizontal
- 4) Shield filters from direct radiant heat. Follow the following for the filter mounting height:
 - No exposed cooking flame—1-1/2' minimum to filter
 - Charcoal and similar fires—4' minimum to filter
 - Provide removable grease drip pan
 - Establish a schedule for cleaning drip pan and filters and follow it diligently

Commercial Kitchens

Efficient ventilation is an important factor in kitchen design. It must effectively remove cooking fumes and odours and the products of combustion given off by gas cooking apparatus, and ensure an adequate supply of comparatively fresh replacement air without creating uncomfortable draughts.

The main points when preparing a scheme are:

- 1) **Give an adequate air flow-** Use a minimum ventilation rate of 25 ACH for commercial kitchens, increasing these figures as necessary to deal with higher than average loading and cooking equipment. When calculating the amount of air necessary to give the selected ACH it is usual to base the volume of the kitchen on a height of 3m. This will automatically compensate for different ceiling or roof heights by increasing the ventilation rate for a low ceiling, and reducing it for a high ceiling.
- 2) **Specific Volumes for Cooking Equipment-** Current practice for commercial kitchen ventilation extends the guidelines for sizing ventilation schemes. Whilst retaining the minimum of 20-30 ACH, specific quantities of air to be provided for each piece of cooking apparatus are now available. Therefore, when the details of the equipment are known, a more accurate assessment of the air volume required can be made. These requirements can result in substantially higher rates of extraction than the minimum rates, and will take much of the uncertainty out of deciding by how much the minimum must be exceeded. The volumes can be used for determining both general extraction and canopy extraction requirements.

Kitchen Cooking Equipment Volume Requirements

Apparatus	m ³ /h	l/s	ft ³ /min (cfm)
Cookers per m ²	1080	300	640
Pastry ovens	1080	300	640
Fish fryers	1620	450	950
Grills	900-1080	250-300	530-640
Steak grills	1620	450	950
Salamanders	1620	450	950
Boiling pans (140-180 liter)	1080	300	640
Steamers	1080	300	640
Sink (sterilizing)	900	250	530
Bain Marie	720	200	420
Tea sets	540-900	150-250	320-530

Alternatively, calculations can be based on the number of meals prepared per hour, multiplied by 10-15, to give an extract volume in litres per second.

Locate extract units as high as possible and as near the source of the fumes as convenient. Hot moist fumes from cooking operations rise fast to ceiling level, and unless they are removed

quickly from that level they will spread over ceiling, walls and windows depositing the moisture content and grease as it condenses on the cooler surfaces. Roof lights and lantern lights are sometimes an ideal location for extract units in a commercial kitchen as they are usually over some cooking equipment at or near the centre of the kitchen, and it is a simple matter to fit roof fans in the glazing. If due to some obstruction it is not possible to site the unit at high level directly above the cooker, then keep it at high level and move it a foot or two to one side. This is better than putting the unit immediately above the cooker but only half way up the wall, as the velocity of the steam and fumes would carry them past the unit to ceiling level where they would spread horizontally and hang about for some time before cooling sufficiently to drop to the level of the extract point. This is a common fault in domestic kitchens, the low siting of the unit sometimes allowing cooking fumes to float through the top of a doorway before they can sink low enough to be extracted by the fan.

- 3) **Use canopies** over 'heavy' cooking equipment, particularly in commercial kitchens, to collect and 'hold' the fumes at source. The removal of fumes and steam from cooking and industrial processes should be done as near to the source as possible. Warm fumes and steam rises quickly and spread over a comparatively large area of the kitchen and must be 'picked up' and removed quickly. To deal with this sort of local problem by increasing the general ventilation rate of the room is not always economical or convenient due to the large volume of air extraction necessary to reduce the spread of the fumes. In such cases a canopy, or hood, would be fitted directly above the equipment and overlapping it by up to 300 mm all round to collect the fumes. The canopies and fans should be of sufficiently large capacity to 'hold' and carry away the fumes without undue spillage from the mouth of the canopy. To achieve this, the velocity of the air through the open area between the canopy and the equipment must be sufficiently high to draw in fumes near the edge of the equipment against the eddying effects of local draughts which could be caused by the movement of people around the equipment.

Estimating Air Volume

Where the items of cooking equipment to be placed under a canopy are known, the total of the volumes of air required for each piece of equipment will constitute the extract volume to be provided by the canopy extract fan/s. Where the equipment is not known, the formula shown below can be used. This formula uses the base area of the canopy, rather than the open perimeter area used in earlier formulae, and more closely matches the volume of hot air rising from the cooking equipment. The volumes obtained by this formula should be regarded as minimums and no harm will result if they are increased by 50%.

$$\text{Vol. m}^3/\text{s} = L \text{ (m)} \times W \text{ (m)} \times K,$$

Where

K =

- 0.25 for domestic
- 0.30 for Light Commercial
- 0.40 for Commercial and Light Industrial
- 0.50 for Heavy Commercial and Industrial

(The factor K represents the face velocity (m/s) of the airflow at the canopy)

Example

A canteen kitchen (equivalent to a light commercial kitchen having face velocity of 0.3 m/s) is to have a canopy 3 m x 1.25 m and covering cooking equipment not yet specified. Find the air volume required.

Solution

$$\text{Air req. m}^3/\text{s} = 3 \times 1.25 \times 0.3 = 1.125 \text{ m}^3/\text{s} \text{ (4050m}^3/\text{h)}$$

Other points to consider:

- 1) Minimum height from floor to underside of canopy 2m
- 2) Air replacement based on 75-85% of extracted air
- 3) Temperature of replacement air must not be below 10°C when coming into contact with cooked food
- 4) Maximum duct velocity 1200 feet per minute
- 5) Plastic flexible ducting should not be used to extract from kitchen canopies, as it is very difficult to clear and would constitute a fire hazard. Steel ductwork should be used, with adequate access panels for cleaning. In special cases, flexible metal ducting could be used, but only where it is short enough to be easily dismantled for cleaning or replacement. Canopy grease filters are necessary to remove the bulk of the oil and fat droplets from the air before it passes along ducting and through extract fans.
- 6) Ensure ample air replacement openings well distributed to eliminate local draughts and to spread the supply of fresh air. Some air replacement from adjoining rooms is not a disadvantage as the flow of air through the doorways will reduce the possibility of fumes from the kitchen passing through to these adjoining rooms. Extract units should be switched on as soon as any cooking apparatus is in use to prevent a build-up of hot fumes, and should be left running for 20 to 30 minutes after cooking is finished to clear away any residual fumes and hot air convected from the cooker surfaces.
- 7) Where a fish fryer is used no fire dampers should be fitted in the ventilation extract duct unless any statutory requirement exists otherwise but adequate cleaning facilities should be provided.
- 8) Canopy, ducting and lagging should be made from non-combustible material. Where ducting passes through other floors between the kitchen and the external weathering cowl, it should be enclosed in fire-resisting construction at least equal to the standard of fire resisting construction at least equal to the standard of fire resistance required in the floor.

Laboratory Ventilation & Chemical Storage Areas

- 1) Provide a minimum of ten air exchanges per hour.
- 2) The ventilation system should shut down when the fire alarm is activated and be capable of manual restarting.
- 3) Pressure differences should be maintained such that air flows from low to high hazard spaces.
- 4) Dilution ventilation systems should have the capacity to increase air flow under emergency conditions such as a spill.
- 5) All chemicals should be maintained in a properly designed chemical storage area. This includes flammables, poisons and corrosives cabinets. The venting of flammables cabinets is not recommended, unless local codes require it. The National Fire Protection Association standards do not require venting but if the cabinet is vented it must not compromise the cabinet. If you vent the cabinet be sure you consult with an engineer or industrial hygienist to avoid compromising the cabinet or violating the code.

Local Exhaust Ventilation for Fume hoods:

- 1) The chemical fume hood is the primary engineering control for limiting exposure in laboratories and often serves as the OSHA designated area
- 2) Locate the fume hood to avoid doorways, high traffic areas, windows or any other structure which might create disruptions in air flow. **Note:** A hood having a face velocity of 100 fpm is

equivalent to an air flow rate of 1 mile per hour. Opening or closing a door can create a 5 mph air flow and compromise the fume hood.

- 3) The hood should have a face velocity of 60-100 fpm of non turbulent air.
- 4) The hood should be equipped with an airfoil to reduce turbulence at the hood opening.
- 5) The top slot of the hood should be fixed at 0.5-0.75 inch open and the bottom slot should be full open. **Note:** Consult the manufacturer’s recommendations to achieve maximum efficiency.
- 6) The fan should be located outside the building.
- 7) Exhausts should be located away from air intakes and should project above the roofline. NFPA Standards require a minimum of 7 feet.
- 8) Fume hoods should be equipped with a velocity indicator. Ideally the hood should be equipped with a velocity alarm.
- 9) Fume hoods should not be used to store chemicals or equipment.
- 10) The minimum amount of equipment and/or chemicals for the specific procedure should be in the fume hood.
- 11) Locate equipment at least 6 inches behind the sash opening.
- 12) Never work in fume hood with the sash open more than the safe operating position. This should be clearly marked on the side of the hood.
- 13) When conducting demonstrations involving the sudden release of energy, be sure the sash is closed completely and that all cracks are covered.
- 14) Before using the fume hood, conduct a brief visual inspection to confirm that the slots are not blocked, that the hood is providing the required face velocity, that the sash is not cracked and that it slides freely and that no obvious defects are present.
- 15) The fume hood should be tested at least quarterly and an inspection sticker affixed to the side of the hood. Do not use fume hoods without inspection stickers or hoods having expired stickers.
- 16) Exhaust hoods and canopies should be designed to capture the unwanted fumes or dust irrespective of other air currents in the vicinity.
- 17) Because of the normally large volumes of ventilation air required all means of heat recovery should be considered.

Dilution Ventilation V/s Local Exhaust Systems – A Comparison

In general a system employing the dilution method will usually be indicated where the contaminant originates at scattered points dispersed generally throughout the area. A combination of local exhaust and dilution methods is often economical since well designed exhaust hoods or openings removing the bulk of the contamination will greatly reduce the air volumes required for dilution purposes. There are advantages and disadvantages to the use of either dilution ventilation or local exhaust ventilation in terms of costs and effectiveness. Table below compares the two types.

Dilution Ventilation		Local Exhaust Ventilation	
Advantages	Disadvantages	Advantages	Disadvantages
Usually lower	Does not completely	Captures	Higher cost for

Dilution Ventilation		Local Exhaust Ventilation	
Advantages	Disadvantages	Advantages	Disadvantages
equipment and installation costs.	remove contaminants.	contaminant at source and removes it from the workplace.	design, installation and equipment.
Requires less maintenance.	Cannot be used for highly toxic chemicals.	Only choice for highly toxic airborne chemicals.	Requires regular cleaning, inspection and maintenance.
Effective control for small amounts of low toxicity chemicals.	Ineffective for dusts or metal fumes or large amounts of gases or vapors.	Can handle all sorts of contaminants including dusts and metal fumes.	
Effective control for flammable or combustible gases or vapors.	Requires large amounts of heated or cooled makeup air.	Requires smaller amount of makeup air since smaller amounts of air are being exhausted.	
Best ventilation for small dispersed contaminant sources or mobile sources.	Ineffective for handling surges of gases or vapors or irregular emissions.	Less energy costs since less makeup air to heat or cool.	

Assessment

Various techniques can be used in the assessment of building ventilation systems and their effectiveness. These include:

- 1) Measurement of air velocities could be done either in the ductwork to enable air flows to be calculated or in the room to detect air movement. Measurement in the room is often difficult because velocities are low, typically less than 60 FPM.
- 2) The use of visualization techniques, for example, smokes generators, to show the pattern of air movement.
- 3) The use of tracers gases such as sulphur hexafluoride or particles such as potassium iodide to detect and trace air movement through a building. Tracer gases can also be used to measure actual ventilation air change rates in the building. This is done by releasing the tracer once and then measuring the rate of decay (i.e. fall in concentration) or by continuously releasing tracer gases at a known rate and measuring the equilibrium concentration.
- 4) Monitoring for airborne contaminants from a process or combustion equipment and monitoring for carbon dioxide from building occupants.

Note that for tracers or for airborne contaminants is a specialized technique and should be carried out by competent people with suitable equipment.
