



PDHonline Course M333 (4 PDH)

HVAC Design for Pharmaceutical Facilities (GMP's)

Instructor: A. Bhatia, B.E.

2020

PDH Online | PDH Center

5272 Meadow Estates Drive
Fairfax, VA 22030-6658
Phone: 703-988-0088
www.PDHonline.com

An Approved Continuing Education Provider

HVAC Design for Pharmaceutical Facilities (GMP's)

A. Bhatia, B.E.

In pharmaceutical manufacturing, how space conditions impact the product being made is of primary importance. The pharmaceutical facilities are closely supervised by the U.S. food and drug administration (FDA), which requires manufacturing companies to conform to cGMP (current Good Manufacturing Practices). These regulations, which have the force of law, require that manufacturers, processors, and packagers of drugs to take proactive steps to ensure that their products are safe, pure, and effective. GMP regulations require a quality approach to manufacturing, enabling companies to minimize or eliminate instances of contamination, mix ups, and errors.

The GMP for HVAC services embraces number of issues starting with the selection of building materials and finishes, the flow of equipment, personnel and products, determination of key parameters like temperature, humidity, pressures, filtration, airflow parameters and classification of cleanrooms. It also governs the level of control of various parameters for quality assurance, regulating the acceptance criteria, validation of the facility, and documentation for operation and maintenance.

Various countries have formulated their own GMPs. In the United States, it is regulated by several documents such as Federal Standard 209, code of Federal regulations CFR 210 & 211 etc, which are revised and updated from time to time. The European Community has a "Guide to Good Manufacturing Practice for Medicinal Products" and in the United Kingdom it is BS 5295. The World Health Organization (WHO) version of GMP is used by pharmaceutical regulators and the pharmaceutical industry in over one hundred countries worldwide, primarily in the developing world. In some countries, the GMP follows largely the country of the principal technology provider. All GMP's have one common theme.....

“CLEANLINESS, CLEANLINESS and CLEANLINESS”

What can HVAC do?

HVAC system performs four basic functions:

1. Control airborne particles, dust and micro-organisms – Thru air filtration using high efficiency particulate air (HEPA) filters.
2. Maintain room pressure (delta P) – Areas that must remain “cleaner” than surrounding areas must be kept under a “positive” pressurization, meaning that air flow must be from the “cleaner” area **towards** the adjoining space (through doors or other openings) to reduce the chance of airborne contamination. This is achieved by the HVAC system providing more air into the “cleaner” space than is mechanically removed from that same space.
3. Maintain space moisture (Relative Humidity) – Humidity is controlled by cooling air to dew point temperatures or by using desiccant dehumidifiers. Humidity can affect the efficacy and stability of drugs and is sometimes important to effectively mould the tablets.
4. Maintain space temperature - Temperature can affect production directly or indirectly by fostering the growth of microbial contaminants on workers.

Each of above parameter is controlled and evaluated in light of its potential to impact product quality.

What HVAC can't do?

1. HVAC can not clean up the surfaces of a contaminated surfaces, room or equipment
2. HVAC can not compensate for workers who do not follow procedures

We will learn about the specific design aspects later in this course, but first we will briefly discuss the generic pharmaceutical process.

PHARMACEUTICAL PROCESS

The task of the pharmaceutical manufacturer is to combine the medicinally active agents provided by a fine chemicals plant, or by extraction from vegetable, animal or other source, with suitable inactive ingredients so that the end product may be used in the correct dosage to produce the effect needed.

Simplified Process

Figure below illustrates a simplified diagram of the chemical synthesis process for pharmaceuticals. There are five primary stages in chemical synthesis: (1) reaction, (2) separation, (3) crystallization, (4) purification, and (5) drying. Each of these five stages is described below.

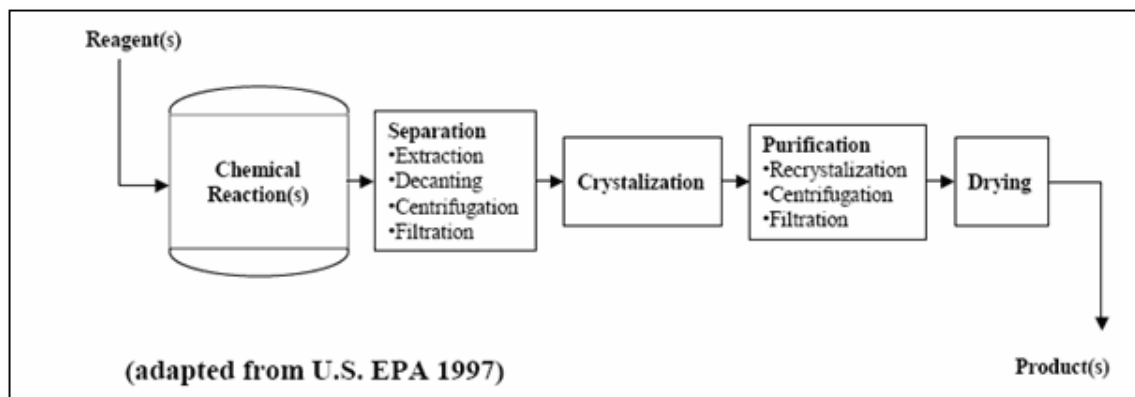

Reaction(s) –

In the reaction process, raw materials are fed into a reactor vessel, where reactions such as alkylations, hydrogenations, or brominations are performed. The most common type of reactor vessel is the kettle-type reactor generally made of stainless steel or glass-lined carbon steel, range from 50 to several thousand gallons in capacity. The reactors may be heated or cooled, and reactions may be performed at atmospheric pressure, at elevated pressure, or in a vacuum. Generally, both reaction temperature and pressure are monitored and controlled. Nitrogen may be required for purging the reactor, and some intermediates may be recycled back into the feed. Some reactions are aided via mixing action provided by an agitator. A condenser system may be required to control vent losses. Reactors are often attached to pollution control devices to remove volatile organics or other compounds from vented gases.

Separation –

The main types of separation processes are extraction, decanting, centrifugation, and filtration. The extraction process is used to separate liquid mixtures.

- Extraction process is used to separate liquid mixtures. It takes advantage of the differences in the solubility of mixture components i.e. a solvent that preferentially combines with only one of the mixture components is added to the mixture. Two

streams result from this process: the extract, which is the solvent-rich solution containing the desired mixture component, and the raffinate, which is the residual feed solution containing the non-desired mixture component(s).

- Decanting is a simple process that removes liquids from insoluble solids that have settled to the bottom of a reactor or settling vessel. The liquid is either pumped out of the vessel or poured from the vessel, leaving only the solid and a small amount of liquid in the vessel.
- Centrifugation is a process that removes solids from a liquid stream using the principle of centrifugal force. A liquid-solid mixture is added to a rotating vessel—or centrifuge—and an outward force pushes the liquid through a filter that retains the solid phase. The solids are manually scraped off the sides of the vessel or with an internal scraper. To avoid air infiltration, centrifuges are usually operated under a nitrogen atmosphere and kept sealed during operation.
- Filtration separates fluid/solid mixtures by flowing fluid through a porous media, which filters out the solid particulates. Batch filtration systems widely used by the pharmaceutical industry include plate and frame filters, cartridge filters, nutsche filters, and filter/dryer combinations.

Crystallization -

Crystallization is a widely used separation technique that is often used alone or in combination with one or more of the separation processes described above. Crystallization refers to the formation of solid crystals from a supersaturated solution. The most common methods of super saturation in practice are cooling, solvent evaporation, and chemical reaction. The solute that has crystallized is subsequently removed from the solution by centrifugation or filtration.

Purification -

Purification follows separation, and typically uses the separation methods described above. Several steps are often required to achieve the desired purity level.

Re-crystallization is a common technique employed in purification. Another common approach is washing with additional solvents, followed by filtration.

Drying -

The final step in chemical synthesis is drying the product (or intermediates). Drying is done by evaporating solvents from solids. Solvents are then condensed for reuse or disposal. The pharmaceutical industry uses several different types of dryers, including tray dryers, rotary dryers, drum or tumble dryers, or pressure filter dryers. Prior to 1980, the most common type of dryer used by the pharmaceutical industry was the vacuum tray dryer.

Today, however, the most common dryers are tumble dryers or combination filter/dryers. In the combination filter/dryer, input slurry is first filtered into a cake, after which a hot gaseous medium is blown up through the filter cake until the desired level of dryness is achieved. Tumble dryers typically range in capacity from 20 to 100 gallons. In tumble dryers, a rotating conical shell enhances solvent evaporation while blending the contents of the dryer. Tumble dryers utilize hot air circulation or a vacuum combined with conduction from heated surfaces.

Product Extraction

Active ingredients that are extracted from natural sources are often present in very low concentrations. The volume of finished product is often an order of magnitude smaller than the raw materials, making product extraction an inherently expensive process.

Precipitation, purification, and solvent extraction methods are used to recover active ingredients in the extraction process. Solubility can be changed by pH adjustment, by salt formation, or by the addition of an anti-solvent to isolate desired components in precipitation.

Solvents can be used to remove active ingredients from solid components like plant or animal tissues, or to remove fats and oils from the desired product. Ammonia is often used in natural extraction as a means of controlling pH.

Fermentation -

In fermentation, microorganisms are typically introduced into a liquid to produce pharmaceuticals as by-products of normal microorganism metabolism. The fermentation process is typically controlled at a particular temperature and pH level under a set of

aerobic or anaerobic conditions that are conducive to rapid microorganism growth. The process involves three main steps: (i) seed preparation, (ii) fermentation, and (iii) product recovery.

Seed preparation -

The fermentation process begins with seed preparation, where inoculum (medium containing microorganisms) is produced in small batches within seed tanks. Seed tanks are typically 1-10% of the size of production fermentation tanks (U.S. EPA 1997).

Fermentation -

After creating the inoculum at the seed preparation stage, the inoculum is introduced into production fermentors. In general, the fermentor is agitated, aerated, and controlled for pH, temperature, and dissolved oxygen levels to optimize the fermentation process. The fermentation process lasts from hours to weeks, depending on the product and process.

Product Recovery -

When fermentation is complete, the desired pharmaceutical byproducts need to be recovered from the fermented liquid mixture. Solvent extraction, direct precipitation, and ion exchange may be used to recover the product. Additionally, if the product is contained within the microorganism used in fermentation, heating or ultrasound may be required to break the microorganism's cell wall. In solvent extraction, organic solvents are employed to separate the product from the aqueous solution. The product can then be removed from the solvent by crystallization. In direct precipitation, products are precipitated out of solution using precipitating agents like metal salts. In ion exchange, the product adsorbs onto an ion exchange resin and is later recovered from the resin using solvents, acids, or bases.

Formulation of Final Products

The final stage of pharmaceutical manufacturing is the conversion of manufactured bulk substances into final, usable forms. Common forms of pharmaceutical products include tablets, capsules, liquids, creams and ointments, aerosols, patches, and injectable dosages. Tablets account for the majority of pharmaceutical solids.

To prepare a tablet, the active ingredient is combined with a filler (such as sugar or starch), a binder (such as corn syrup or starch), and sometimes a lubricant (such as magnesium stearate or polyethylene glycol). The filler ensures the proper concentration of the active ingredient; the purpose of the binder is to bond tablet particles together. The lubricant may facilitate equipment operation during tablet manufacture and can also help to slow the disintegration of active ingredients.

Tablets are produced via the compression of powders. Wet granulation or dry granulation processes may be used. In wet granulation, the active ingredient is powdered and mixed with the filler, wetted and blended with the binder in solution, mixed with lubricants, and finally compressed into tablets. Dry granulation is used when tablet ingredients are sensitive to moisture or drying temperatures. Coatings, if used, are applied to tablets in a rotary drum, into which the coating solution is poured. Once coated, the tablets are dried in the rotary drum; they may also be sent to another drum for polishing.

Capsules are the second most common solid oral pharmaceutical product in the United States after tablets (U.S. EPA 1997). Capsules are first constructed using a mold to form the outer shell of the capsule, which is typically made of gelatin. Temperature controls during the molding process control the viscosity of the gelatin, which in turn determines the thickness of the capsule walls. The capsule's ingredients are then poured (hard capsules) or injected (soft capsules) into the mold.

For liquid pharmaceutical formulations, the active ingredients are weighed and dissolved into a liquid base. The resulting solutions are then mixed in glass-lined or stainless steel vessels and tanks. Preservatives may be added to the solution to prevent mold and bacterial growth.

If the liquid is to be used orally or for injection, sterilization is required.

Ointments are made by blending active ingredients with a petroleum derivative or wax base. The mixture is cooled, rolled out, poured into tubes, and packaged.

Creams are semisolid emulsions of oil-in-water or water-in-oil; each phase is heated separately and then mixed together to form the final product.

In designing the air-conditioning system for pharmaceutical plants, it is very important to study the application, identify various factors affecting the particulate count and decide the level of contamination that can be permitted.

What is Particulate?

Simply stated, airborne particles are solids suspended in the air. The size of contaminants and particles are usually described in microns; one micron is one-millionth of a meter. In English units one micron equals 1/25,400 inch. To give a perspective, a human hair is about 75-100 microns in diameter.

Air, whether it is from outside or re-circulated, acts as a vehicle for bacterial and gaseous contaminants brought in by the movement of people, material, etc. Since many of these air borne contaminants are harmful to products and people, their removal is necessary on medical, legal, social or financial grounds. There are two main sources of particulates, external and internal sources.

External sources consist of the following:

- Outside make-up air introduced into the room: this is typically the largest source of external particulates
- Infiltration through doors, windows and other penetration through the cleanroom barriers

Control Action:

- Make-up air filtration
- Room pressurization
- Sealing of all penetrations into the space

Internal sources consist of the following:

- People in the clean area: people are potentially the largest source of internally generated particulates

- Cleanroom surface shedding
- Process equipment
- Material ingress
- Manufacturing processes

Control Action:

- Design airflow path to shield humans from surroundings
- Use of air showers [to continually wash occupants with clean air]
- Using hard-surfaced, non-porous materials such as polyvinyl panels, epoxy painted walls, and glass board ceilings
- Proper gowning procedures, head wear

A super clean environment with controlled temperature and relative humidity has now become an essential requirement for a wide range of applications in Pharmaceutical Plants.

What is a Cleanroom?

A cleanroom is defined as a room in which the concentration of airborne particles is controlled. The cleanrooms have a defined environmental control of particulate and microbial contamination and are constructed, maintained, and used in such a way as to minimize the introduction, generation, and retention of contaminants.

Cleanroom classifications are established by measurement of the number of particles 0.5 micron and larger that are contained in 1 ft³ of sampled air. Generally class 100 to 100,000 rooms are used in the pharmaceutical industry. [Note - rooms may be classified as clean at class 1 or 10 for other applications, particularly in the microchip /semiconductor industry].

Cleanrooms classified in the United States by Federal Standard 209E of September 1992 and by the European Economic Community (EEC) published guidelines "Guide to

Good Manufacturing Practice for Medical Products in Europe, which are more stringent than U.S. FDA regulations.

U.S FEDERAL STANDARD 209E

Table below derived from Federal Standard 209E shows the air cleanliness classes:

Class Names		Class Limits			
		0.5 Micron		5 Micron	
SI	English	m ³	ft ³	m ³	ft ³
M 3.5	100	3,530	100	-	-
M 4.5	1,000	35,300	1,000	247	7
M 5.5	10,000	353,000	10,000	2,470	70
M 6.5	100,000	3,530,000	100,000	24,700	700

Table Interpretation:

1. Class 100 (M 3.5) is the area where the particle count must not exceed a total of 100 particles per cubic foot (3,530 particles per m³) of a size 0.5 microns and larger.
2. Class 10,000 (M 5.5) is the area where the particle count must not exceed a total of 10,000 particles per cubic foot (353,000 particles per m³) of a size 0.5 microns and larger or 70 particles per cubic foot (2,470 particles per m³), of a size 5.0 microns and larger.
3. Class 100,000 (M 6.5) is the area where the particle count must not exceed a total of 100,000 particles per cubic foot (3,530,000 particles per m³) of a size 0.5 micron and larger or 700 particles per cubic foot (24,700 particles per m³) of a size 5.0 microns and larger.

4. All pharmaceutical facilities belong to one or other class of cleanroom. General acceptance is:

- Tableting facilities - Class 100,000
- Topical & oral liquids - Class 10,000
- Injectables class - Class 100

EUROPEAN COMMUNITY GUIDELINES

European Community defines cleanrooms in alpha Grades A, B, C and D. The classification is given on two different conditions: 1) "At-Rest" and 2) "In-Operation"

"At -Rest" - 'state of cleanrooms is the condition where the production equipment is installed and operating but without any operating personnel.

"In- Operation" - state of cleanrooms is the condition where the installation is functioning in the defined operating mode with the specified number of personnel working.

Grade	At Rest		In Operation	
	Maximum permitted number of particles per m ³ equal to or above <u>0.5 micron</u>	Maximum permitted number of particles per m ³ equal to or above <u>5 micron</u>	Maximum permitted number of particles per m ³ equal to or above <u>0.5 micron</u>	Maximum permitted number of particles per m ³ equal to or above <u>5 micron</u>
A (Laminar Airflow Workstation)	3500	0	3500	0

Grade	At Rest		In Operation	
	Maximum permitted number of particles per m ³ equal to or above <u>0.5 micron</u>	Maximum permitted number of particles per m ³ equal to or above <u>5 micron</u>	Maximum permitted number of particles per m ³ equal to or above <u>0.5 micron</u>	Maximum permitted number of particles per m ³ equal to or above <u>5 micron</u>
B	35,000	0	350,000	2,000
C	350,000	2,000	3,500,000	20,000
D	3,500,000	20,000	Not defined	Not defined

Notes

Grade-A classification is the most stringent of all. It requires air in the immediate proximity of exposed sterilized operations to be no more than 3500 particulates per cubic meter, in a size range of 0.5 micron and larger, when measured not more than one foot away from the work site and upstream of the air flow, during filling/closing operations. This applies both at “at rest” and “in-operation” condition. Grade-A areas are expected to be completely free from particles of size greater than or equal to 5 micron both “at rest” and “in-operation” condition.

Besides “at-rest” and “in-operation” cleanroom states, another condition most commonly used by HVAC contractors is “As – Built” condition. ‘As built’ cleanrooms are those which are ready with all services connected but without equipment and personnel.

The HVAC contractors responsibility generally lies up to the ‘as built’ or ‘at rest’ cleanroom stage and often the pharmaceutical companies specify higher cleanliness levels for these stages than the ‘operational’ stage.

Typical Examples

Typical examples of Grade- A areas include filling zone, Stopper bowls, Open ampoules and vials making aseptic connections

Typical examples of Grade-B areas are Aseptic preparation and filling area, Aseptic receiving area, Aseptic changing room and solution preparation room.

These are less critical areas. Typical examples of these areas are 1) Changing room, 2) Material Entry air locks

Comparison of US Federal standard 209E v/s EEC

Class 100 is equivalent to (Grades A and B)

Class 10,000 is equivalent to (Grade C)

Class 100,000 is equivalent to (Grade D)

FACILITY CLASSIFICATION

Pharmaceutical facility typically consists of a series of integrating classes of rooms to match with the requirements of the manufacturing process. There are some basic requirements that must be satisfied so that the air in the sterile rooms is correct for the activities related to the manufacturing process. Each sterile room must be clinically independent from the surrounding area and are produced by “aseptic” processing. Aseptic processing is a method of producing a sterile (absence of living organisms) product. The objective of aseptic processing methods is to assemble previously sterilized product, containers and closures within specially designed and controlled environments intended to minimize the potential of microbiological or particulate contamination.

Cleanrooms classifications differ for sterile and non-sterile areas. These are called by many names viz.:

Non-sterilized operation = controlled area = non-aseptic application

Sterilized operation = critical Area = aseptic application

Controlled Areas

U.S standards define the “controlled area” as the areas where Non-sterilized products are prepared. This includes areas where compounds are compounded and where components, in-process materials, drug products and contact surfaces of equipment, containers and closures, are exposed to the plant environment.

Requirement - Air in “controlled areas” is generally of acceptable particulate quality if it has a per cubic foot particle count of not more than 100,000 in size range of 0.5 micron and larger (Class 100,000) when measured in the vicinity of the exposed articles during periods of activity. With regard to microbial quality, an incidence of no more than 2.5 colony forming units per cubic foot is acceptable.

In order to maintain air quality in controlled areas... airflow sufficient to achieve at least 20 air changes per hour and, in general, a pressure differential of at least 0.05 inch of water gauge (with all doors closed) is recommended.

Critical Areas

U. S standards define “Critical Areas”, as the areas where Sterilized operations are carried out. These shall have aseptic cleanrooms.

Requirement - Air in “critical areas” is generally of acceptable particulate quality if it has a per cubic foot particle count of not more than 100 in size range of 0.5 micron and larger (Class 100) when measured in the vicinity of the exposed articles during periods of activity. With regard to microbial quality, an incidence of no more than 0.1 colony forming units per cubic foot is acceptable.

In order to maintain air quality in sterile areas... laminar airflow at velocity of 90 feet per minute \pm 20 and, in general, a pressure differential of at least 0.05 inch of water gauge (with all doors closed) is recommended. No specific air change rate is specified by Fed and EEU standards.

TYPES OF CLEANROOMS

Cleanrooms are also categorized by the way supply air is distributed. There are generally two air supply configurations used in cleanroom design: 1) Non-unidirectional and 2) Unidirectional.

Non-unidirectional air flow

In this airflow pattern, there will be considerable amount of turbulence and it can be used in rooms where major contamination is expected from external source i.e. the make up air. This turbulent flow enhances the mixing of low and high particle concentrations, producing a homogenous particle concentration acceptable to the process.

Air is typically supplied into the space by one of two methods. The first uses supply diffusers and HEPA filters. The HEPA filter may be integral to the supply diffuser or it may be located upstream in the ductwork or air handler. The second method has the supply air pre-filtered upstream of the cleanroom and introduced into the space through HEPA filtered work stations. Non-unidirectional airflow may provide satisfactory control for cleanliness levels of Class 1000 to Class 100,000.

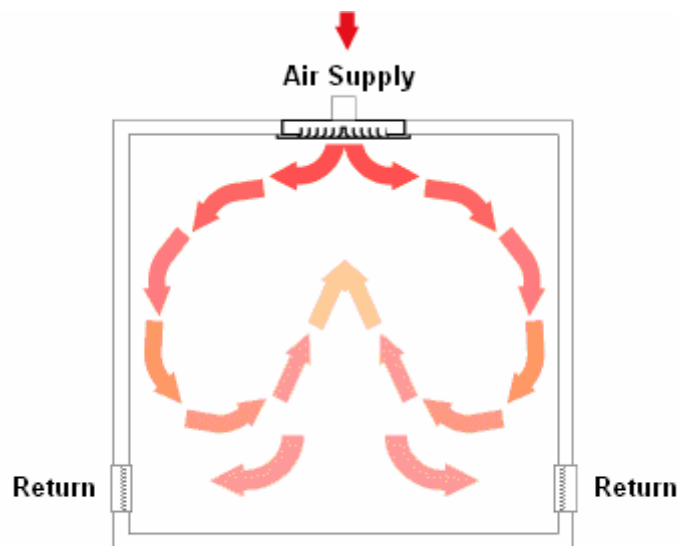

Non-Unidirectional Air Flow Pattern

Unidirectional air flow

The unidirectional air flow pattern is a single pass, single direction air flow of parallel streams. It is also called 'laminar' airflow since the parallel streams are maintained within 18 deg - 20 deg deviation. The velocity of air flow is maintained at 90 feet per minute ± 20 as specified in Federal Standard 209 version B although later version E does not specify any velocity standards.

Unidirectional cleanrooms are used where low air borne contaminant levels are required, and where internal contaminants are the main concern.

They are generally of two types:

1. Vertical down-flow cleanrooms where the air flow is vertical 'laminar' in direction.
2. Horizontal flow where the air flow is horizontal 'laminar' in direction.

In vertical down-flow arrangement, clean make-up air is typically introduced at the ceiling and returned through a raised floor or at the base of the side walls. Horizontal flow cleanrooms use a similar approach, but with a supply wall on one side and a return wall on the other.

Typically a down-flow cleanroom consists of HEPA filtered units mounted in the ceiling. As the class of the cleanroom gets lower, more of the ceiling consists of HEPA units, until, at Class 100, the entire ceiling will require HEPA filtration. The flow of air in a down-flow cleanroom bathes the room in a downward flow of clean air. Contamination generated in the room is generally swept down and out through the return.

The horizontal flow cleanroom uses the same filtration airflow technique as the down-flow, except the air flows across the room from the supply wall to the return wall.

Between the two, the vertical down-flow pattern yield better results and is more adaptable to pharmaceutical production.

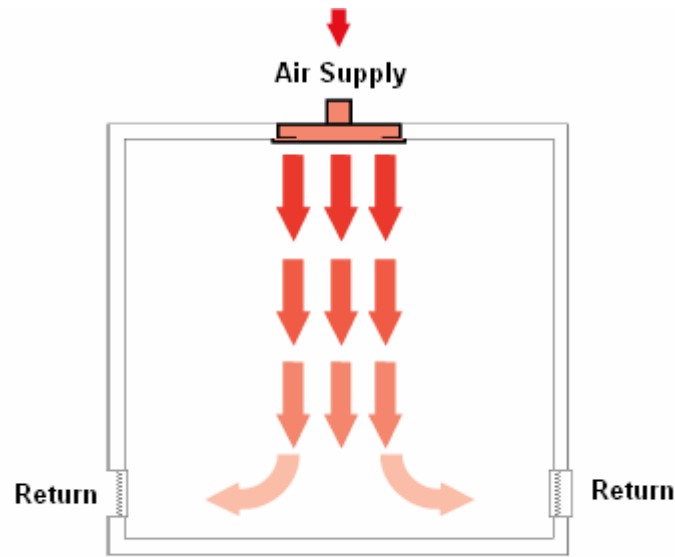

Unidirectional Air Flow Pattern (Vertical)

How do Cleanrooms HVAC different from a normal comfort air conditioned space?

A cleanroom requires a very stringent control of temperature, relative humidity, particle counts in various rooms, air flow pattern and pressure differential between various rooms of the clean air system. All this requires:

1. **Increased Air Supply:** Whereas comfort air conditioning would require about 2-10 air changes/hr, a typical cleanroom, say Class 10,000, would require 50 - 100 air changes. This additional air supply helps, to dilute the contaminants to an acceptable concentration.
2. **High Efficiency Filters:** The use of HEPA filters having filtration efficiency of 99.97% down to 0.3 microns is another distinguishing feature of cleanrooms.
3. **Terminal Filtration and Air Flow pattern:** Not only are high efficiency filters used, but a laminar flow is sought.
4. **Room Pressurization:** With the increased fresh air intake, cleanrooms are pressurized in gradients. This is important to keep external particulates out of clean spaces.

SYSTEM DESIGN

The HVAC design process begins with meetings with process engineers, architects, and representatives from the owner or facility user. The process and instrument diagrams (P&IDs) are reviewed, and a general understanding of the process is conveyed to all interested parties. Operation of the facility is reviewed, and any plans for future additions or modifications are discussed.

After the initial meeting, a written basis of design is produced that describes the regulations and codes that will govern the design. Spaces are defined by function, and temperature and humidity requirements are determined. Room classifications are listed and adjacency of spaces and pressure relationships are documented. Any unusual or unique facility requirements must also be designed into the HVAC system at this time, such as emergency backup or redundancy for HVAC systems. This is also the stage of the design process during which alternate studies are conducted to compare options for the HVAC system. The cost of a backup or redundant HVAC supply system may be compared with the cost of product loss or experiment interruption should temperatures or airflow go out of control or specification. Heat recovery from exhaust systems and thermal storage are examples of other potential areas for study. Airflow diagrams are produced that show areas served by a particular air handling system including supply, return, exhaust, and transfer air between spaces. The basis of design also describes major equipment to be used and the level of quality of components and construction material.

The efficacy of the system design is based on proper consideration of the following factors:

1. Building construction and layout design
2. Defining the HVAC requirements system-wise and then room-wise.
 - Cleanliness level
 - Room temperature, relative humidity

- Room pressure
 - Air flow pattern
3. Cooling load and Airflow compilation
 4. Selection of air flow pattern
 5. Pressurization of rooms
 6. Air handling system
 7. Duct system design and construction
 8. Selection, location and mounting of filtration system
 9. Defumigation requirement
 10. Commissioning, performance qualification and validation
 11. Testing and validation
 12. Documentation

BUILDING DESIGN, CONSTRUCTION AND LAYOUT

Proper building design and planning of the flow of personnel, material and equipment is essential for achieving and maintaining the design levels of cleanliness and pressure gradients. If the building layout and its construction are poor there is very little that an air-conditioning system designer can do to satisfy the end-user needs.

Building Layout

From an HVAC standpoint it is desirable to keep similarly classified areas as physically close to each other as possible so they can be connected to the same air handling system, thereby minimizing duct runs, cost, and air system complexity. It is also imperative that spaces be arranged to allow people to move around without disrupting the cleanliness or containment of the spaces.

It is NOT desirable to mix dirty and clean systems or suites that may allow the possibility of cross-contamination from one suite to another. Leaks can develop in a filter, or some source of contamination could find its way through the air supply or return systems, providing a source for cross-contamination.

Sterile zones are normally divided into three sub zones:

1. Main sterile zone or white zone
2. Cooling zone which is also a white zone
3. Set of three change rooms: black, grey and white in ascending order of cleanliness

In order to achieve a pressure gradient, it is imperative that zones are located such that the gradient is unidirectional, i.e. the room with the highest pressure should be located at one end and the room with the lowest pressure should be located near the opposite end. This type of planning can simplify balancing of system pressures to a great extent.

Entry for people to the main sterile room should be from a set of three change rooms: black, gray and white ...in that order. Entry for equipment and material must be through "AIRLOCKS". No area should directly open into the sterile room.

Building Construction

The internal particulate generation always is the focus of any cleanroom design. The internal generation consists of those from building elements such as walls, floor, ceiling, etc., from equipment, and most importantly from operators. The building construction itself has to be "tight" with minimum of uncontrolled infiltration and leakages. This is very important in the case of buildings for formulation and sterile production. Materials used in the construction of the pharmaceutical facilities should be hard-surfaced. There are few special points of interest as noted below:

1. All material used in construction should be non chipping and cleanable. Wall and floor finishes should not shed particulates and should provide self-cleaning surfaces.
2. All exposed surfaces should be smooth, impervious and unbroken

3. No un-cleanable recesses and a minimum of projecting ledges, shelves, cupboards and equipment
4. Sharp corners should be avoided between floors, walls and ceiling
5. False ceilings and the tile joints in the floor should be completely sealed
6. Pipes, ducts and other utilities should be installed so they do not create recesses
7. Sinks and drains should be prohibited in grade Class 100 areas
8. All doors in the sterile area should have airtight construction. Special gaskets should be provided on the door frame and drop seals provided at the bottom of the door, if necessary.
9. Epoxy painting should be carried out in these areas.

Areas w/o False Ceiling

Special attention should be given to the type of ceiling. The commonly followed trend is to eliminate false ceilings and to provide instead a concrete slab on top of which are located the air handling units and ducting. Cutouts in this slab are used for housing the terminal filters. Access to these filters is from top of the slab. Care should be taken to adequately reinforce this slab to accommodate the weight of the air handling units, piping and ducting.

In the case of NO false ceiling is considered, the air-conditioning system is required to be designed before slab construction is started. Make sure:

1. To correctly identify the location and size of the cutouts for terminal filters. Mounting frames for terminal filters/terminal filter boxes should be grouted at the time of casting the slab.
2. To correctly identify the location and size of the cutouts for return air risers and inserts in the slab.
3. To correctly identify additional cutouts required for other MEP services.

4. To correctly determine the air handling equipment size and location that should be matched with the cut-out location and size.
5. To provide curbing at the perimeter of the cutouts to prevent water seepage into the working area.
6. To correctly provide floor drain locations for air handling units.
7. To consider water proofing in areas where air handling units are located.

Areas with False Ceiling

In the case of a false ceiling in the sterile area, the following points should be considered:

1. Inserts should be provided for false ceiling supports and mounting of filters.
2. To prevent fungus growth and eliminate air leakage, the false ceiling should be of NON-shedding variety, such as aluminum or PVC coated CRCA sheet.
3. False ceiling members should be designed to support part of the weight of terminal filters.
4. Proper sealing must be provided between panels and between filters and panels to avoid air leakage.

Ceiling Construction

The ceiling of the cleanroom is another potential location for contaminants to enter the clean zone. Pressurization of the cleanroom helps to prevent this; however this can lead to contaminants from the processes in the cleanroom being forced out into the area surrounding the cleanroom. To reduce the chance of this happening, the cleanroom ceiling is sealed. The type of seal is determined by the cleanliness class of the cleanroom. For Class 1,000 and higher (less clean), the ceiling grid can be gasketed aluminum T-bar with a 1" face tee. A Class 100 cleanroom should have a gasketed aluminum T-bar grid with 2" face tees and Class 10 and cleaner should have a modular / T-bar ceiling grid with a gel seal.

The gasketed T-bar system has an integral vinyl, or similar material, gasket. The gasket is compressed between the base of the tee and the ceiling panel or diffuser. Hold down clips is used to maintain the compression on all non-access related panels.

The gel grid T-bar system has a groove running the full length of both sides of the tee. The groove is filled with a suitable sealing gel. This type of ceiling is typically used in cleanrooms where 100% of the ceiling consists of filters or fan filter units. The filters and/or fan filter units have a knife edge around the perimeter which goes into the gel forming a seal.

The type of ceiling panels used in a cleanroom ceiling also depends on the cleanliness class of the space. Class 1,000 and above (less clean) can have cleanroom approved, vinyl covered panels or blank aluminum panels while Class 100 and cleaner can only have blank aluminum panels.

Ceiling grid support is determined by cleanliness class as well. Class 100 and cleaner should have all-thread rod with strut and turnbuckles while Class 1,000 and above should have 12 ga hanger wires to the grid and 10 ga hanger wires to the filters. The hanger wires should be installed at the grid intersections.

Summarizing

Cleanroom Classification	Ceiling System
Class 100	2" T-bar with gasket, extruded aluminum
Class 1,000	1" T-bar with gasket, extruded aluminum
Class 10,000	1" T-bar with gasket, extruded aluminum
Class 100,000	Side access HEPA filter housings

HVAC REQUIREMENTS

Define the HVAC requirements system-wise and then room-wise. The requirements defined are: 1) room temperature, 2) relative humidity, 3) cleanliness level and 4) room pressure.

Room Temperature (T)

Room temperature (T) is not critical as long as it provides comfortable conditions. Generally areas are designed to provide room temperatures from 67 and 77°F with a control point of 72°F. Lower space temperatures may be required where people are very heavily gowned and would be uncomfortable at “normal” room conditions.

Relative Humidity (RH)

Relative humidity (RH) on the other hand, is of greater importance in all the production areas. While most of the areas could have a RH of $50 \pm 5\%$, facilities designed for handling hygroscopic powders need to be at $30 \pm 5\%$. Automatic control of the RH is essential for maintaining continued product quality. Control of humidity is necessary for personal comfort, to prevent corrosion, to control microbial growth, and to reduce the possibility of static electricity. We will discuss more about the RH control in the subsequent sections.

Control Airborne Particles (C)

Of all the design goals, it is the quality of air cleanliness of the space and prevention of contamination which are of utmost importance. Externally generated particulates are prevented from entering the clean space through the use of proper air filtration. The normally accepted air quality standards for both sterilized and non-sterilized areas are tabulated below:

Operation	Parameters	United States	European Economic Community

Operation	Parameters	United States	European Economic Community
Non-sterilized product or container (U.S : Controlled Area)	Cleanroom type	Class 100,000	Grade C
	Maximum particle size (0.5 micron or above)	100,000/ft ³	350,000/m ³
	Maximum viable organisms	2.5/ft ³	100/m ³
Sterilized product or container (U.S: Critical Area)	Cleanroom type	Class 100 in Class 10,000 background	Grade A in Grade B background
	Maximum particle size (0.5 micron or above)	100 /ft ³	3,500/m ³
	Maximum viable organisms	0.1 /ft ³	<u>Grade A</u> : 1 /m ³ <u>Grade B background</u> : 5/m ³

Room Pressure Differential (DP)

Cleanroom positive pressurization is desired to prevent infiltration of air from adjacent areas. The normally accepted air pressurization standards for both sterilized and non-sterilized areas are tabulated below:

Operation	Parameters	United States	European Economic Community
Non-sterilized product or container (U.S : Controlled Area)	Space pressurization	0.05 inch-w.g	Positive
Sterilized product or container (U.S: Critical Area)	Space pressurization	0.05 inch-w.g or higher	Positive

COOLING LOADS

Pharmaceutical buildings as a rule are totally enclosed without any fenestrations. This is to maintain a 'tight' building to minimize uncontrolled infiltration. As a result, the room sensible loads are essentially a contribution from process equipment, lighting and personnel. Fan heat from recirculating fans can also be a large heat contributor in clean spaces. The density of equipment loads is low excepting in the tablet manufacturing facility covering granulation, drying and tableting.

Heat-loss calculations must also be made to determine heat loss through walls, roof, and floor. No credit should be taken for process heat gain in this calculation, since the process could be dormant and the space would still need to be maintained at proper temperature.

A major contribution of the cooling load comes from outside air entering the air handling unit. There is also considerable diversity in the equipment loads based on the production

patterns. All these result in a low room sensible load density varying from as low as 15 Btu/hr sq-ft to 40 Btu/hr sq-ft. Hence the system design lays emphasis on control and maintenance of relative humidity. The room temperature is normally held at 70°F, whereas the relative humidity is held at $50 \pm 5\%$ in most of the areas. In a few areas it is maintained at $35 \pm 5\%$ or lower depending on the product characteristics.

Formulas to determine cooling loads are available from HVAC handbooks and ASHRAE standards.

AIRFLOW SHEETS

Once the cooling load is determined, the next step is to calculate the dehumidified airflow using psychrometric analysis or computer analysis. These results are compared with airflow quantities required to establish the minimum air required to satisfy both the space cooling load requirements and air cleanliness classification.

The airflow sheets should be developed on full-size drawings and should show air quantities supplied, returned, and exhausted from each space. They also must show air transferred into and out of spaces, and, while quantities should be shown, they will probably require field modification to attain pressurization. The airflow sheet is a useful tool for transfer of information to the owner or user, for agency reviews, for transmission of information to HVAC designers, and for other engineering disciplines. These documents are also invaluable to construction contractors and for system checking by construction managers and balancing contractors. Airflow sheets provide a pictorial description of each air system and show how the elements comprising the system are related.

AIRFLOW PATTERN

The air distribution has to be appropriate with the class of cleanroom. Air turbulence in the space can cause particulates which have settled onto the floor and work surfaces to become re-entrained in the air. Air turbulence is greatly influenced by the configuration of air supply and return grilles, people traffic and process equipment layout.

The following measures are normally taken to control the air flow pattern and hence the pressure gradient of the sterile area:

1. Class 100 and lower zones must necessarily have unidirectional (laminar) flow with 100% HEPA filter coverage in the ceiling or wall. Return must be picked up from the opposite side.
2. Air flow velocities of 90 fpm \pm 20 (70 fpm to 110 fpm) are recommended as standard design for Class 100 cleanroom systems.
3. The vertical down-flow configuration is preferred. Per EEC standards, laminar work station with vertical flow requires 0.3 m/s velocity whereas the horizontal work stations require 0.45 m/s velocity. When horizontal flow is used the work place must be immediately in front of the clean air source so that there is nothing in between which could emit or cause uncontrolled turbulence and consequent contamination.
4. Class 1000 and above are generally non-unidirectional with the supply air outlets at the ceiling level and the return air at the floor level.
5. This air should be supplied at a much higher volume than its surrounding area ensuring a higher velocity and pressure in the clean zone relative to the perimeter.

Return Air System

The air return system is another critical component of the cleanroom air distribution system. The return points shall be positioned low down near the floor in the walls and spaced as symmetrically as building construction allows. Return grilles shall be made as long as convenient to increase the collection of dust particles over a larger area.

Return air grilles in the main sterile zones should be located to avoid dead air pockets. While locating the return grille, care should be taken to avoid placing the grille near a door opening into an adjoining lower pressure room. This is done to prevent creation of a low pressure zone near the door, thus preventing air leakage from the low pressure to high pressure room at the time of door opening.

On each return air riser manually operated dampers shall be provided for control. These dampers should preferably be operated from the non-sterile areas.

Mixed Areas

It is possible to create Class 100 space within Class 10,000 areas at background. For example, if a small localized operation in big Class 10,000 volume requires Class 100 standard, there is no point to put the entire area as Class 100. This will be very expensive. For such areas, install “localized laminar flow workstations”, which are commercially available in horizontal or vertical flow patterns generally recirculating within the clean space.

AIR CHANGES

Air change rate is a measure of how quickly the air in an interior space is replaced by outside (or conditioned) air. For example, if the amount of air that enters and exits in one hour equals the total volume of the cleanroom, the space is said to undergo one air change per hour. Air flow rate is measured in appropriate units such as cubic feet per minute (CFM) and is given by

$$\text{Air flow rate} = \text{Air changes} \times \text{Volume of space} / 60$$

The normally accepted air change rates for both sterilized and non-sterilized areas are tabulated below:

Operation	Parameters	United States	European Economic Community
Non-sterilized product or container (U.S : Controlled Area)	Airflow rate	Minimum 20 air changes/hr	Higher than 20 air changes/hr
Sterilized product or container (U.S: Critical Area)	Airflow rate	90 ft/min \pm 20	<u>Grade A</u> : Laminar work station, vertical 0.3 m/s and

Operation	Parameters	United States	European Economic Community
			horizontal 0.45 m/s <u>Grade B</u> : Higher than 20 changes per hour

Even though various design guidelines and standards are available, there is no clear-cut guidance for air changes per hour especially for “sterilized areas”.

Table below indicates a typical range of air change rates generally used to achieve the desired room cleanliness classifications and to meet federal and local regulations. These air change rates vary widely in actual practice due to the level of activity, number and type of particulate generators in a room (such as people and equipment), and room size and quality of air distribution. It is generally best to use historic data to establish airflows, which is usually done with significant input from the owner based on past experience or preference. There is nothing sacred about an air change rate as long as minimum airflow rates required by code are maintained. The goal is to achieve desired particulate cleanliness levels and stay at or above a 20 air changes/h minimum.

Class	ACH	% HEPA Coverage	Air Velocity (FPM)
100,000	24 -50	10 - 20%	5 -10
10,000	50 - 100	20 - 40%	10 - 20
1,000	150 - 200	40 – 60%	25 - 35

100	270 - 330	80 – 100%	70 -110
-----	-----------	-----------	---------

How to estimate air change rate?

Most pharmaceutical cleanrooms depend on the principle of dilution to control their particles. The air-change rate leads to dilution of space. Simply put, the dilution rate in terms of air change rate per hour is given by following equation, assuming no infiltration as the room is pressurized:

$$v = g / (x - s)$$

Where

- s is the supply air particulate concentration in particles per ft
- v is the supply air volume flow rate in terms of air-change rate per hour
- g is the internal generation rate in particles per ft³ per hour
- x is room or return air concentration in particles per ft³

Example

For a typical Class 10,000 cleanroom space with a typical internal generation of approximately 5,000 per CFM, and supply air through 99.97% HEPA filters, what shall be the required air-change rate?

Solution

The supply rate can be estimated using equation:

$$v = g / (x - s)$$

Where

- $g = 5000 * 60 \text{ ft}^3$ per hour

- $x = 10,000$
- $s = 3$ for 99.97% efficient HEPA filters

$$v = 5000 * 60 / (10000 - 3) = 30 \text{ air changes per hour}$$

Of course, in the case that internal generation is significantly higher, more air changes would be required.

It is important to note that high air change rate (ACR) equate to higher airflows and more energy use. In most cleanrooms, human occupants are the primary source of contamination. Once a cleanroom is vacated, lower air changes per hour to maintain cleanliness are possible allowing for setback of the air handling systems. Variable speed drives (VSD) should be used on all recirculation air systems allowing for air flow adjustments to optimize airflow or account for filter loading. Where VSD are not already present, they can be added and provide excellent payback if coupled with modest turndowns. The benefits of optimized airflow rates are:

- 1) **Reduced Capital Costs** - Lower air change rates result in smaller fans, which reduce both the initial investment and construction cost. A 20 percent decrease in ACR will enable close to a 50 percent reduction in fan size.
- 2) **Reduced Energy Consumption** - The energy savings opportunities are comparable to the potential fan size reductions. According to the fan affinity laws, the fan power is proportional to the cube of air changes rates or airflow. A reduction in the air change rate by 30% results in a power reduction of approximately 66%. A 50 percent reduction in flow will result in a reduction of power by approximately a factor of eight or 87.5 percent.

Designing a flexible system with variable air flow can achieve the objectives of optimized airflow rates. Existing systems should be adjusted to run at the lower end of the recommend ACR range through careful monitoring of impact on the cleanroom processes.

PRESSURIZATION

Pressurization prevents the infiltration from adjacent spaces. Pressurization of clean

areas is required to keep products from being contaminated by particulate and/or to protect people from contact with harmful substances by physical means or inhalation. This can be easily accomplished by supplying more air than the cumulative of what is returned, exhausted or leaked from the room.

Standard 209E specifies that the minimum positive pressure between the cleanroom and any adjacent area with lower cleanliness requirements should be 0.05 in. w.g with all entryways closed. During facility operation as doors are opened, the design differential is greatly reduced, but air must continue to flow from the higher to lower pressure space, even though at a reduced flow rate. To maintain a differential of 0.05 in water, a velocity of approximately 900 ft/min (4.7 m/s) should be maintained through all openings or leaks in the room, such as cracks around door openings. In theory the actual required velocity is less, but in actual practice it is prudent to use 900 ft/min. *[Note that one-inch water gauge pressure is approximately equivalent to wind velocity of 4000 feet per minute].*

The amount of air being returned has a bearing on room pressurization and will depend on the process taking place within the clean space. For a space requiring positive pressurization, the return air volume is typically 15% less than the total supply air volume. While calculating supply air quantities for various rooms, allowances should be made for process equipments like tunnels that cross room pressure boundaries and open doors, if any. Of particular importance is exhaust air from equipment and hoods that may be on or off at different times during occupied periods. These variations must be dynamically compensated for to maintain room pressurization. To maintain the required balance, numerous systems are employed using manual and automatic dampers, constant and variable volume air control boxes, and elaborate airflow sensing devices. These components are combined with control systems and sensing devices to ensure that the room pressurization is maintained.

The pressure gradients are monitored with 'U' tube manometers or magnahelic gauges. Alarm and warning systems may also be provided when the pressure gradients are disturbed.

Pressure Gradient

There should be a net airflow from aseptic rooms to the non-aseptic areas. This is possible only if there is pressure gradient between two adjacent rooms. Air always flow from high pressure to low pressure region. Pressure between two rooms is differential pressure “DP”.

With reasonably good building construction and airtight doors and windows, it is normally possible to achieve and maintain the following pressures between various zones.

Atmosphere	0 Pa
Change rooms	25 Pa
Non-aseptic areas	25 Pa
Aseptic areas	
Cooling corridors	45 Pa
Access corridors	35 Pa
Manufacture laboratory	55 Pa
Filling rooms	55 Pa
Change rooms	25 Pa

Note: [10 Pa = 1 mm w.g. = 0.04 inch w.g.]

Where major demarcations of pressure are required, air locks are used. These are small rooms with controlled airflows acting as barriers between spaces. It minimizes the volume of contaminated air that is introduced into the cleaner room when its door is opened...remember, with ZERO pressure differential and on open door, the entire volume of the dirtier room can eventually find its way to the cleaner room. It is important that

- Doors open/close FAST (to minimize time of contamination). Both airlock doors should not be opened simultaneously.
- High air changes (high airflow or small volume room) to permit faster “recovery”.

- People use smaller airlock (faster recovery time = less time to wait in airlock)

The pressure differential exerts a force on the door. If the force is too great (0.15 in water/36 Pa), the door may not close fully or may be difficult to open. This is particularly important in large complex facilities where many levels of pressurization may be required. Many facilities now use sliding doors, and it is essential that the seals be carefully designed to allow minimum leakage and proper containment or pressurization.

Alarms that sound to indicate loss of pressurization are valuable features and essential in the HVAC design of critical areas.

Room Seals and Doors

In most facilities the openings around the doors between rooms are where leaks occur due to pressure differentials between rooms. In making rooms tight any room openings must be sealed with a proper sealant that will not promote growth of organisms and can be easily cleaned. Areas to be sealed include ceiling tiles, lighting fixtures, pipe penetrations, telephone outlet penetrations, and any cracks or openings that appear in the structure. A typical door would have the following dimensions and crack area at the perimeter: door size, 3 ft wide by 7 ft high; cracks at top and sides, 1/8 in with an undercut of 1/4 in. The calculated area around the door is equal to 0.24 ft². To achieve 0.05 in water pressure differential across the door, approximately 215 CFM of airflow through the cracks is required. Door seals around the top and sides are usually made of closed cell neoprene and should generally be used to reduce the crack area. To reduce the undercut, a drop type seal, which is commercially available, should be used. The drop type is preferred to a wipe type, since it will not mar or leave residue on the floor. Air used for pressurization must be accounted for in system calculations. Air through cracks or openings is accounted for as transfer air and shown in the HVAC room balance table.

FILTRATION

Proper air filtration is crucial for cleanroom controls. In dusty production areas such as grinding, granulation, coating, tableting etc., the filters not only control the atmosphere contamination but also hold the internally generated particulates.

Atmospheric dust is a mixture of dry particles, fibers, mist, smoke, fumes, live or dead organisms. The air-borne particle size varies from 0.01 micron to as much as 100 microns. Less than 2.5 micron particles are considered as fine and particles over 2.5 micron is regarded as “coarse”. Fine particles are airborne for a longer time and could settle on vertical surfaces. Coarse particles, products of mechanical abrasion like in grinding and granulation departments, have lower airborne life time and are subject to gravitational settlement. The air conditioning systems in the pharmaceutical industry have to handle both fine and coarse particulates depending on the production pattern and the filter regime has to be appropriate.

Air Filters

- Air filters capture solid materials
- Can be “roughing” filter to capture a significant percentage of total mass (30%)
- Can be “high efficiency” to capture a higher percentage of mass, plus some of the “weightless” fine particles (85% - 95%)
- Can be “high efficiency particulate” to remove virtually 100% of the material weight and 99.97% or more of all particles

Terminal HEPA Filters

HEPA (High efficiency particulate air) filters have 99.97% to 99.997% removal efficiency on 0.3 μ particles. In other words, only less than 0.03% of all particles of 0.3 microns or larger can get through such a filter. So if the return air contains 10,000 particles per ft³, its concentration would be reduced down to three particles per ft³ after it goes through the filter. Ultra low particulate air (ULPA) filters have 99.9997% removal efficiency on 0.12 μ particles, but these are generally recommended for cleanliness level of Class 10 and low (more cleaner classification), primarily for semi-conductor industry.

HEPA filters use sub-micron glass fiber media housed in an aluminum framework and are available in two types of constructions: 1) Box type and 2) Flanged type.

Box type filters are more suitable for housing within the ceiling slab cutout where removal of filter is from above. Whenever filter removal is not from above e.g. in case of

filter being mounted in false ceiling, flanged type of filters is required. With flanged type of filters, additional housing is also required to facilitate the mounting of filters and transfer the load to false ceiling members. Aluminum / stainless steel slotted type protective grilles can be provided under the terminal filters. The housing and grilles should be epoxy/stove enamel painted. Sealing of filters to frames is an installation problem and is best solved by using a filter frame with a gel-like seal into which the filter fits. The sealant selected should not promote growth of organisms and can be easily cleaned.

These filters are available in thicknesses of 6" and 12" and have pressure drop of 1 inch-w.g. when clean and generally need to be replaced when the pressure drop exceeds 2 inch-w.g. The most popular HEPA filter location is in the room ceiling using standard laminar flow outlets nominally 24" x 48".

Pre-filters to HEPA Filters

In order to prolong the service life of HEPA filters, pre-filters are recommended to filter out majority of particles above 1 micron. However, dust holding capacity of these filters is poor. Therefore, in case the application requires a filtration system with good dust holding capacity, bag type filters with fiberglass scrim cloth media are recommended to give efficiencies ranging from 85% (down to 20 microns) to 99.97% (down to 5 microns).

Pre-filters are available in various sizes with 6" and 12" thickness and with pressure drop in the range of 0.2 to 0.25 inch- w.g. Pre-filters are normally mounted in a separate plenum with access door after supply air fan discharge at an appropriate location. Normally flanged filters are used for mounting in such plenums. It should be convenient to clean and replace these filters without disturbing the rest of the filtration system.

Roughing Filter

These filters are normally provided before the cooling coil in the air handling unit and at fresh air intakes. Efficiency of these filters is in the range of 80% down to 20 microns and they can be easily cleaned by washing. Filters with synthetic media sandwiched between HDPE layers in thickness of 2 inches are highly suitable for such applications.

Filters Performance Ratings

Filters are distinguished by their efficiency, airflow resistance and dust holding capacity. Air filters are commonly described and rated on their collection efficiency, pressure drop (or airflow resistance), and particulate-holding capacity. The American Society of Heating, Refrigerating, and Air Conditioning Engineers (ASHRAE) have developed standards 52.1-1992 and 52.2-1999 that classify filters in terms of "Arrestance" and "Efficiency".

Per ASHRAE standards 52.1-1992, Arrestance means a filter's ability to capture dust and describes how well an air filter removes larger particles such as dirt, lint, hair, and dust. The dust holding capacity of a filter is the amount by weight of standard dust that the filter will hold without exceeding the resistance 0.18 inch-w.g. for low-resistance filters, 0.50 inch-w.g. for medium-resistance filters and 1.0 inch-w.g. for high-resistance filters. Be aware that arrestance values may be high; even for low-efficiency filters, and do not adequately indicate the effectiveness of certain filters for chemical or biological protection. Dust spot efficiency measures a filter's ability to remove large particles; those tend to soil building interiors. Dust arrestance can be expressed as

$$\mu_a = 1 - C_a / C_b$$

Where

- μ_a = dust arrestance
- C_a = dust concentration after filter
- C_b = dust concentration before filter

Since large particles make up most of the weight in an air sample, a filter could remove a fairly high percentage of those particles while having no effect on the numerous small particles in the sample. Thus, filters with an arrestance of 90 percent have little application in cleanrooms.

Per ASHRAE standards 52.2-1999, Efficiency measures the ability of the filter to remove the fine particles from an airstream by measuring the concentration of the material upstream and downstream of the device. If a supplier of filter only indicates efficiency as 95% or 99%, it does not really mean anything unless it specifies the particle size range.

The ASHRAE Standard 52.2-1999 quantifies filtration efficiency in different particle size ranges and rates results as MERV (Minimum Efficiency Reporting Value) between 1 and 16. This numbering system makes it easier to evaluate and compare mechanical air filters and eliminates some of the confusion regarding the overall effectiveness of any type of a mechanical air filter on removing airborne particulates, especially those that are less than 2 microns in size. A higher MERV indicates a more efficient filter.

Filter Testing

The efficiency of a filter is of paramount importance and must be measured in an appropriate way. The common tests on the filters include the dust spot test and DOP tests. The dust spot test is a measure of the ability of the filter to reduce soiling and discoloration. High efficiency filters are tested using Di-octyl Phthalate (DOP) method.

The DOP test is conducted by counting upstream and downstream particulates through a light scattering photometer or any other particulate counter. Test particulates are of uniform 0.3 micron diameter with a density of 80mg/cum produced by condensation of DOP vapor (Dioctyl phthalate or bis - 2 ethylexyl). In essence, if ten thousand (10,000) 0.3 micron sized particles are blown into a HEPA air filter, only 3 particles are allowed to pass through. Thus, you get the 99.97% at .3 micron rating.

Typically the filters are shop tested and the manufacturers typically provide the quality certification for required efficiency to the end user. Table below is a guide line to filter selection.

Areas	Efficiency	Arrestance	Type
Non-aseptic Areas			
Pre-filter 1	20-40% dust spot	75 to 85%	Panel or bag
Pre-filter 2	80-85 dust spot	98%	Panel
Final	95% DOP	-	Panel
Aseptic Areas			
Pre-filter 1	20-40% dust spot	75 to 85%	Panel or bag

Pre-filter 2	80-85% dust spot	98%	Panel
Final	99.97% DOP	-	Panel

All filters are dry type with synthetic and glass fiber. While pre-filters could be cleanable, the final filters are disposable.

BASIC HVAC SYSTEMS

1. Once –thru Air – Air is conditioned, enters the space and is discarded
2. Recirculated Air - Air is conditioned, enters the space and portion is reconditioned. Some may be discarded.

Once – Thru HVAC

What are the advantages of this system?

1. Fresh air – lots of it
2. Can handle hazardous materials, although will need to clean up air leaving the space
3. Exhaust duct is usually easy to route as high velocity = smaller diameter

Disadvantages

1. Expensive to operate, especially when cooling and heating
2. Filter loading very high = frequent replacement
3. Potential need for dust collection/scrubbers/cleanouts

Applications

1. Labs with hoods, potential hazards
2. Bulk Pharmaceutical Chemical (API) plants handling flammable materials
3. Oral Solid Dosage (OSD) plants where potent products/materials exposed

4. Where high potential of product cross-contamination – segregation
5. Some bio API facilities with exposed potent materials

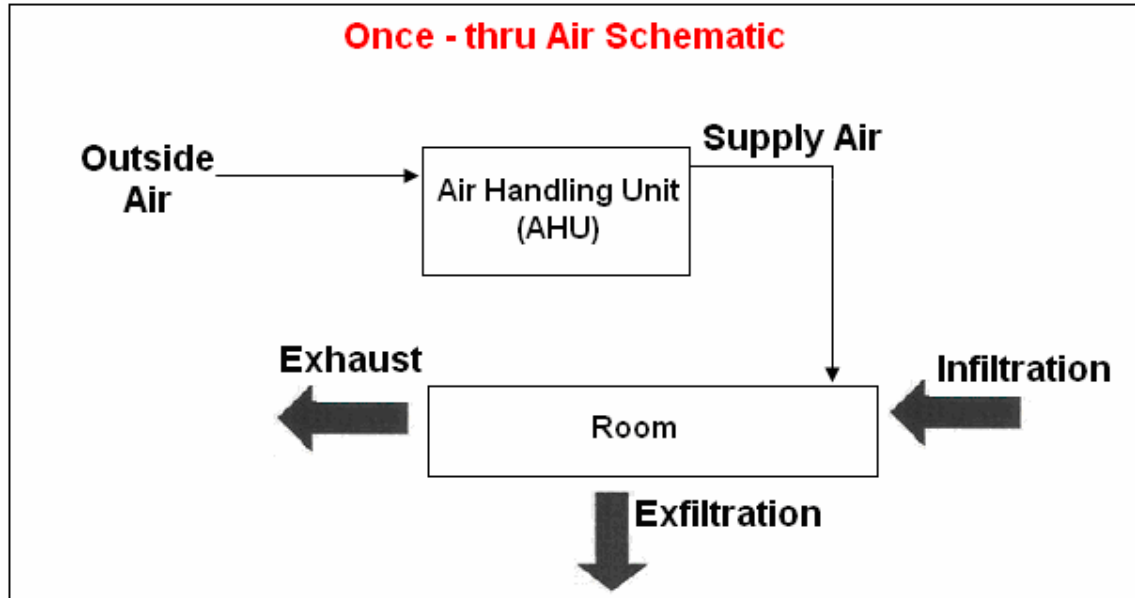

Recirculated HVAC

In pharmaceutical facilities large quantities of air may be required to promote unidirectional flow and air cleanliness. This is particularly true in a class 100 space. In many cases the large quantities of air exceed the requirements for cooling, so it is desirable and possible to recirculate air within the space and only pass enough air through the air handling unit to perform the heating or cooling.

What are advantages here?

1. Usually less air filter loading = lower filter maintenance and energy cost
2. Opportunity for better air filtration
3. Less challenge to HVAC = better control of parameters (T, RH, etc)
4. Less throw-away air = lower cooling/heating cost

Disadvantages

1. Return air ductwork routing to air handler may complicate above ceiling

2. Chance of cross contamination = requires adequate supply air filtration (and sometimes return air filtration)

Applications

1. Classified spaces such as sterile manufacture (few airborne materials, very clean return air)
2. Finished oral solid dosage (OSD) manufacture where product is not airborne with other products in the facility
3. Final bulk APIs, usually with dedicated air handler for each room

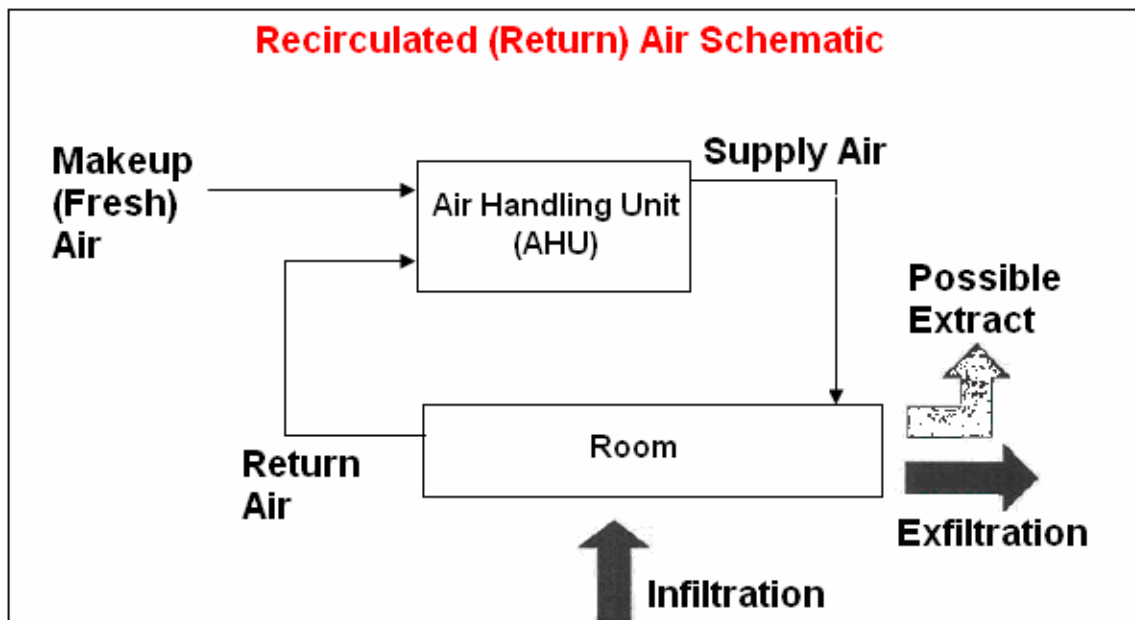

Constant Volume Systems

The most reliable system for pharmaceutical manufacturing areas is constant volume system with terminal reheat (CVRH). This is because; ensuring constant pressure gradient between the adjacent areas is of prime importance.

In a terminal reheat system the air leaving the cooling coil is set at a fixed temperature, and the terminal reheat responds to a space thermostat, turning on heat to satisfy the load. This can waste energy, since air is cooled and then reheated. Many energy codes prohibit this practice for comfort applications, however, where close control of

temperature and humidity is required for process areas the energy conservation requirement is waived. The advantages of reheat systems are that humidity is always controlled (since dehumidification always takes place at the cooling coil) and each space or zone that needs temperature control can easily be accommodated by adding a reheat coil and thermostat. Another advantage of the CVRH system is that airflow is constant, which makes balancing and pressurization easier to main maintain. A reheat system is probably the simplest and easiest of all systems to understand and maintain.

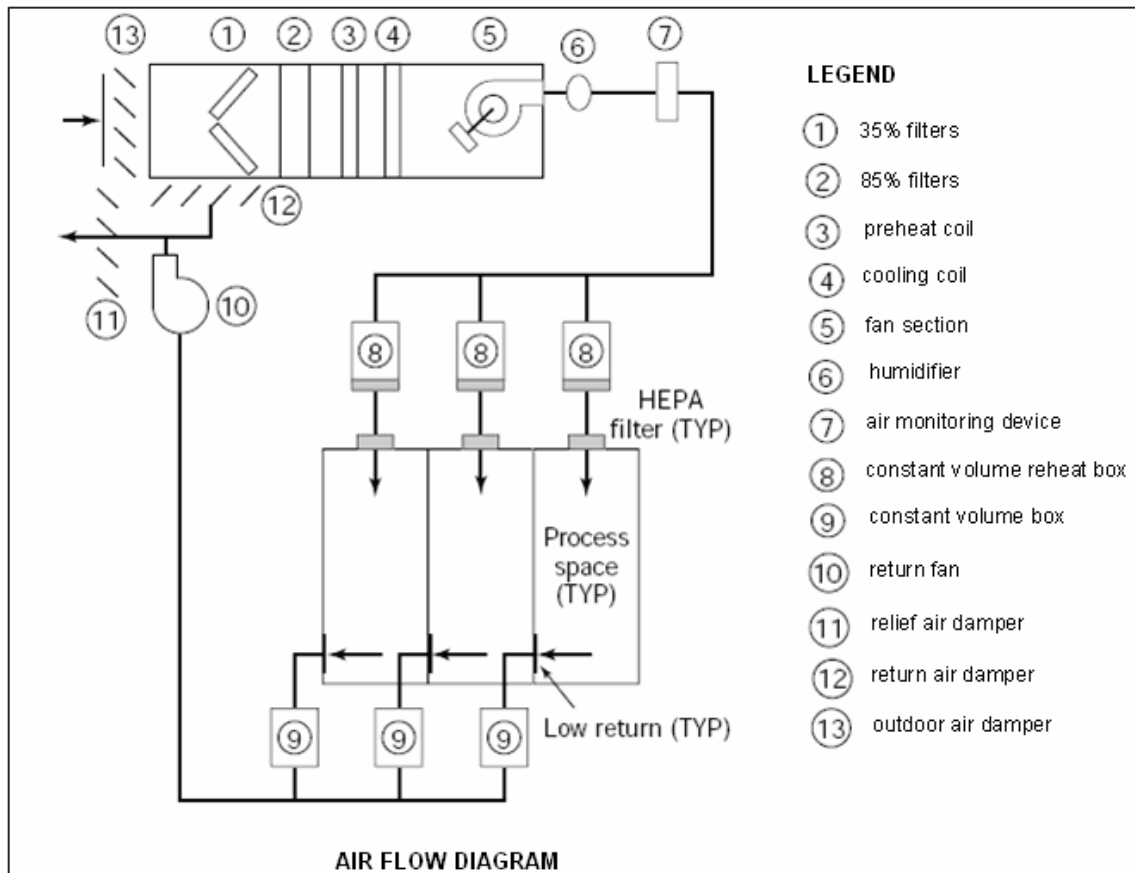

Variable Air Volume Systems

A variable air volume (VAV) system is generally used in administrative areas and some storage spaces where pressure control is not critical, humidity control is not essential, and some variations in space temperature can be tolerated. The VAV system works by delivering a constant temperature air supply to spaces with reductions in airflow as cooling loads diminish. This eliminates the energy used for reheat and saves fan energy, because the total amount of air moved is reduced.

Some form of perimeter heating must be supplied for spaces with exterior walls or large roof heat losses. The perimeter heating can be baseboard radiation or some form of air heating using heating coils. Finned radiation or convection heating devices should not be used in clean spaces, since they are not easily cleaned and allow places for unwanted particulate buildup. Combinations of systems can be used, especially if variable quantities of supply and exhaust air are required for fume hoods or intermittent exhausts.

HVAC EQUIPMENT SPECIFICATIONS

Air Handling Unit

Pharmaceutical air handling systems support clean aseptic environments, so the equipment must be air-tight and epoxy coated.

Conventional air handling units consist of filters, coils, and fans in a metal casing, with an insulation liner applied to the inside of the casing. For pharmaceutical applications the unit casing must be a double skin sandwich of metal with insulation between the metal sheets to provide a smooth, cleanable interior surface that does not foster the growth of organisms.

Units should contain good access doors, view ports, electrical convenience outlets, and interior lighting for maintenance. The casings should be tightly sealed and designed for pressures that are higher than commercial applications due to the generally high system air pressures required for pharmaceutical applications. All sealants and lubricants exposed to the airstream should be food grade to minimize the chance of air contamination.

Chilled water or propylene glycol solutions are generally used for cooling and dehumidification. Direct expansion refrigerant, in which the refrigerant is in the air unit coil, may be used, but these systems are less reliable than chilled water or glycol and are more difficult to control in the narrow air temperature ranges required.

Units designated as draw-through have the coils on the suction side of the fan. Blow-through units have the coils on the discharge side of the fan and have the advantage of a filter downstream of the coils, reducing potential contamination of the supply duct

system. On blow through units an air distribution plate must be installed to properly distribute air evenly over the filter and coils.

While selecting the fan, it should be ensured that at the lower speed the fan does not operate in the un-balanced region. Fans should be provided with a shaft seal near the bearings.

Cooling coil section should be provided with sandwich type of drain pan to collect condensate. It may also be necessary to provide an eliminator after the cooling coil in order to prevent water carry-over into the system.

In case of a heating coil, at least a 0.5 meter space should be kept between coils. All sections consisting of pre-filters, cooling coil, heating coil, etc should be mounted in between the SA and RA fans.

Two sets of fresh air dampers should be provided, one for 10% to 20% and the second for 100% of fan capacity. These dampers are located on the suction side of the return air fan. Proper access should be provided in each section of the air handling unit for routine maintenance and cleaning. 100% intake damper is especially useful during “defumigation” operation discussed later in the course.

Air Handling Unit Location

To avoid cross contamination independent air handling systems should be provided for various discrete operations like manufacturing, coating, tableting, inspection and packing. In some departments there is further segregation of operations which requires a certain degree of control, if not an altogether independent air handling unit.

Air handling systems should be located on a separate equipment floor or zone in order to facilitate service and maintenance without disturbance to the sterile room. They should also be located as close as possible to the main rooms they are serving to minimize larger and longer duct runs.

Location of outdoor air-inlet louvers must be carefully considered. Intakes should be located on the building sidewall high off the ground to minimize dust intake. Intakes should also be away from truck docks or parking lots, where undesirable fumes and particulate are generated. In locating inlets the prevailing winds should also be

considered, and any nearby exhausts or fume concentrations should be avoided to prevent recirculation of exhaust air back into the supply system.

Exhaust Fans Location

Building exhausts are generally collected and ducted to exhaust fans in groups or clusters. Exhaust fans should be located as near to the building discharge as possible since this keeps the duct under a negative pressure and any leaks will be into the duct, and not contaminated air from the duct into an occupied space or mechanical room. For this reason roof locations of fans are preferred, even though this may make service difficult in severe weather conditions. When fans are located in mechanical rooms or interstitial spaces, it is essential to tightly seal the discharge duct before it exits the building in a roof vent or wall louver. Roof penetrations should be kept to a minimum to prevent leaks. Fumes and toxic exhausts should be extended through the roof and terminated well above the roof line in a suitable stack head.

Extremely toxic or dangerous active biological agents may require HEPA filtration or other treatment, such as incineration, before exhaust to the atmosphere.

Return Fans

Return fans are recommended on systems with long duct returns where pressure drops greater than 0.5 in water (120 Pa) are expected. This allows proper total system balance and minimizes suction pressure required from the supply fan. If a return fan is not used, the capacity of the supply fan can be overextended and it may be difficult to limit and properly control the amount of outside air being admitted to the unit. Outside air fluctuations are also more susceptible to exterior wind conditions.

Return fans are also needed when required to provide a negative pressure in rooms that require containment. Return fans can be of standard centrifugal type or an in-line type, which works nicely for installation directly into return ducts in crowded equipment rooms. Return fans may also be required to handle varying quantities of air or provide a constant flow of air at varying pressure conditions. To achieve these conditions some form of damper control, inlet vane, or variable frequency drive motor control is generally used.

Redundancy

If return or exhaust fans are used as part of maintaining containment, it may be desirable to have a backup fan or redundant system. This is essential, if loss of containment can be harmful to humans or would result in an expensive loss of product. Airflow switches, which give a warning in case of fan system failures, are also desirable options for critical systems. The airflow sensing method to prove flow is preferred to an electrical motor indication since the motor could be running with a broken fan belt and the operator would not know that the fan is not moving air.

Dehumidifiers

Dehumidifiers are used to control relative humidity (RH) to lower levels. RH of $50\pm 5\%$ can be achieved by cooling the air to the appropriate dewpoint temperature. When chilled water is supplied at 42–44°F to the cooling coils, a minimum dew point of about 50–52°F can be obtained. This results in a minimum room relative humidity of approximately 50% at 70°. Spaces with high moisture content, it is important to use a cooling coil that is deeper i.e. with higher number of rows. Sometimes additional brine cooling coil is incorporated to further dehumidify the supply air. This will lead to lowering of supply air temperatures downstream the cooling coil, which is reheated by hot water coil or electrical strip heaters before dumped into the space.

In some cases where hygroscopic (products sensitive to moisture) materials are handled, the room RH requirement may be as low as 30 to 35% and may require the use of chemical dehumidifiers. Chemical dehumidifiers are commercially available air handling units that contain a sorbent material (desiccant) that can be a solid or liquid. Wet dehumidifiers use absorbents that change physically during the process. Lithium salt solutions are generally used to remove moisture from conditioned air and are then regenerated by heat, usually using a steam heat exchanger. Dry dehumidifiers use adsorbents that do not experience phase changes during the process. Silica gel and activated alumina are generally used. A rotating wheel is commonly used to remove moisture from the conditioned air. The wheel is regenerated by passing heated outdoor air over the wheel to dry it out. Steam or electric coils are usually employed for regeneration. Depending on the amount of dehumidification required and the amount of outdoor air (usually with a high moisture content), it may be best to combine the dehumidifier with a conventional air handling unit and only dehumidify a small portion of the air or just the outdoor air. The dehumidifier has a high initial cost compared with a

conventional air handling unit. The size should be optimized to do only the required duty with an appropriate safety factor. Knowledgeable vendors in this specialized area should be consulted to find the best combination of dehumidification equipment, system arrangement, and control for the application. These systems also require considerable physical space, energy consumption, and service—important criteria to be considered in system selection.

Humidifiers

In drier locations, makeup air may require the addition of moisture for RH control. There are many commercially available humidifiers, but the most commonly used is “steam grid” humidifier. These are controlled by modulation of a steam valve at the humidifier, and include a chamber to prevent condensation and water droplets in the duct. The valve is controlled by a signal located in the return or exhaust airstream or in a room humidistat. A high-limit stat is placed in the duct downstream of the humidifier to override the controlling stat and prevent condensation in the duct. Placement of the humidifier in the duct is critical and must follow the manufacturer’s recommendations to prevent condensation and provide proper dispersion space. It is important to use clean steam, not plant steam, which may contain boiler chemicals and impurities from deteriorating piping and equipment.

Ductwork Design, Materials & Cleanability

Duct Pressures

Ductwork in pharmaceutical facilities tends to have higher system pressure due to extensive use of filters, volume control devices, and physically complex arrangements. The duct system pressures must be calculated and clearly stated on the contract documents to allow the fabricator to provide the proper metal thickness and construction methods for the required system pressures. System pressures will also change as the system is operated with filters that get dirty or space pressure conditions that vary. Duct systems must allow for these pressure fluctuations and the fans may require speed controls, inlet vanes, or variable pitch blades to match the varying flow and pressure conditions.

Duct materials and shape

Unlined galvanized steel, stainless steel or aluminum ductwork is used in rectangular, round, and elliptical (or flat oval) configurations for the majority of the systems. Round ducting is a natural choice, being self cleaning in shape, wherever space permits.

Because galvanized duct can flake off or rust, it should not be used downstream of the HEPA filters to avoid contamination from the duct system itself. When the HEPA filter is located upstream of the room terminal and a long run of duct is present, the material of choice for the duct is stainless steel, but this is expensive and its use should be minimized. Many systems may also be fumigated or cleaned in place, and the duct material chosen should not be affected by the cleaning agent.

Cleanability

Cleanability of duct systems is important to ensure that if an installed system gets dirty or contaminated it can be cleaned. In the design stage care must be taken to locate access doors in the duct, where they can be easily reached without compromising a process or violating a controlled space. All sealed duct shipped to the site should have only end seals broken, and then quickly resealed, during final installation. In very critical applications the duct is factory cleaned and sealed before shipment to the site. This step removes the oil and other contaminant present during duct construction but is expensive. It may be difficult to find sheet-metal fabricators willing to do this work, since they are not always set up for such procedures.

Following precautions should be taken:

1. Ducts should be sealed with silicone sealant at longitudinal joints in order to make the system airtight. Rubber gaskets should be used at transverse joints.
2. GI flanged joints must be avoided and instead pocket slips or angle iron flanged joints should be used.
3. No acoustic insulation should be provided inside the ducts.
4. Dampers provided in the system should be of compatible duct materials and should have extended handle to accommodate insulation thickness.

5. Return air risers should be designed for velocities not exceeding 1800 fpm with a minimum velocity of 1200 fpm at the highest point in order to carry particulate matter along with return air. However, the inlet velocity at the return grille should be in the range of 300 to 400 fpm gradually increasing the same to 1200 to 1800 fpm.
6. Grilles and diffusers should be flush mounted into ceiling, walls or duct work and all such grilles shall be fabricated from stainless steel or stove enamel/epoxy coated construction.
7. Whenever terminal filters are mounted in the false ceiling, proper sealed access door should be provided to reach the dampers above each filter.

Supply Terminals

In clean spaces, the desired distribution of air is unidirectional. This carries particulate from the ceiling to the floor return and helps to prevent airborne particulate matter from recirculating and contaminating the work space. In most cases it is desirable to recirculate air within a space through a filter since the return air has less particulate than typical outdoor air and does not require extensive heating and cooling. Air terminals should be selected of materials that are non-flaking, non-oxidizing, and are easily wiped clean.

Return Terminals

Return terminals are also an important consideration and are generally located low in the walls for cleanrooms. In class 10,000 to 100,000 rooms low cleanable wall registers are generally used. In cleaner areas low return wall systems, termed *air walls*, are used. The air wall is an almost continuous opening at the base of the wall with the air ducted up in the wall system and collected for return to the air handling system. Air wall inlets are generally located not more than 15 ft in plain view from a supply terminal to reduce the likelihood of turbulence.

The material of construction for the return grilles will be determined by the process taking place in the clean space, though stainless steel is used quite often for its appearance and cleanability. Due to its corrosion resistance, the use of stainless steel grilles also allows for processes to be changed periodically without changing grilles.

Defumigation

Sterile areas are periodically fumigated with formaldehyde vapor that is circulated through areas and air-conditioning equipment in order to sterilize the system. However, formaldehyde vapor must be removed effectively after fumigation is over before starting the actual operations. During defumigation 100% fresh air is provided and this is fully exhausted to remove formaldehyde vapor. The fresh air and exhaust air ducting should be designed for 100% air volume with appropriate dampers to re-set at normal position during normal operation sequence.

The procedures must be developed to accommodate a product spill or accident in a contained space. The ramifications of a spill on the air system, controlled space, and adjacent operations must be evaluated. Cleanup procedures could include fumigation of the air system, which would require operation of a relief connection to the ductwork for venting the fumigant.

EMERGENCY ELECTRICAL POWER

An essential step in the HVAC design process is coordination with the electrical design team. Motor lists for HVAC equipment must be prepared and reviewed with the electrical design team. The need for motors designated for emergency power, variable speed, reduced voltage starting, or other special characteristics must be communicated to the electrical designers early in the design process. The sizing of the emergency generator can be greatly affected by motors required on emergency power from the HVAC system. Fans, equipment, or sensing devices that require interlocks must also be picked up by the electrical designers. The motor list must be kept up to date from project inception through commissioning. The motor list is useful for a reviewing agency, a valuable tool in training plant operators, and a great aid in understanding the HVAC system.

BUILDING CONTROL AND AUTOMATION SYSTEMS

The automatic control system that controls and monitors the HVAC system is called by many names: the automatic temperature control system (ATC), the energy management and control system (EMCS), the building automation system (BAS), or the building management system (BMS).

The control system of choice for major facilities, and even for some small systems, is a direct digital control (DDC) system. Most major control system vendors and many of the smaller vendors offer DDC systems that are similar but contain internal differences. The systems are computer based and have the ability to communicate within and outside the system by coded digital signals. System architecture refers to the major components of the DDC system and their interrelationship. The architecture is developed by determining what components are initially required, what may be required in the future, and how the system may expand as additional requirements are added.

Sequence of Operations

The first element in the design of the system is the development of a sequence of operation, which is a written description of the HVAC and related systems operation. A separate sequence is usually written for each air handling system, describing the complete operation of the system from control of coils and humidifiers to control of the room temperature and humidity. Starting and stopping of the air handling unit fans is outlined, along with interlocking of exhaust or return fans in relation to the main air system fan operation. Generally all fans operate at the same time, which is necessary to maintain pressurization. The sequence also addresses abnormal occurrences such as a smoke detection alarm or failure of an exhaust fan. The sequence describes what happens to system components during an abnormal occurrence. It may be necessary to shut a supply fan down if a major exhaust fan should fail to prevent or minimize the loss of pressurization. The sequence also describes any energy management strategies to be included in the system, such as a night temperature setback or reduced ventilation and exhaust rates during unoccupied periods.

Points List

After the sequence of operation is completed and the airflow diagrams are defined, the next step is to develop the alarm, control, and monitoring points list. This is an all inclusive list of points that are to be connected to the DDC system. There are two major types of points: digital and analog.

A digital point is simpler, generally less expensive, and works on a simple on-off or contact principle. Digital points are used to start and stop fans, indicate an on-off condition, or anything that requires only a single contact.

An analog point is used to measure variables such as temperature, pressure, and flow rate. These points generally use 4- to 20-mA signals that provide varying signals in response to the parameter measured.

The electronic signals used by the BAS may be transduced from variable pneumatic or pressure signals. The points list should include analog control points such as cooling coil valves and room temperatures. Monitoring points can be digital or an analog, and can include fan run, room temperature indication, damper position, and room pressure indication.

Alarm points can be either digital or analog and can include smoke detection in an air handling unit system, high or low environmental chamber temperature, high room humidity, or loss of room pressurization.

Estimate of System Cost

The automatic control and monitoring system is a major cost element in the overall HVAC system for a pharmaceutical facility. After the points list is developed a good estimate can be made for the system cost. Several estimating numbers can be used in providing an educated guess of the cost, with a general range from a low of \$500/point to as high as \$1,200/point.

TESTING, BALANCING, AND CLEANING

For pharmaceutical facilities, establishing pressure differentials between adjacent spaces is the most critical and is very tedious to balance. These differentials are obtained by adjusting airflows, smoke tests, taking pressure readings, and setting controls. This effort can take some time as each facility is different and each room has different leakage characteristics that affect pressurization.

As part of the balancing, you may find that the duct systems or rooms are not as tight as designed and may require additional sealing to obtain the required pressure differentials. Recall that airflows shown on drawings are design values and generally require minor adjustment to achieve the required pressure differentials. A simple solution to many pressurization problems is to keep increasing outdoor air to the system. This can lead to

problems, if design values are exceeded, with heating or cooling coils not meeting this need, resulting in off-design room temperatures and humidity levels. The air handling unit coils will use available cooling capacity to condition excessive quantities of outdoor air, resulting in room supply temperature higher than as designed. Therefore, the best solution first is to tighten the spaces. The optimum time to balance is when few construction workers or facility personnel are in the spaces. The balance should be done with all doors closed, since opening and closing results in system pressure upsets and make balancing difficult.

In general, testing and pre-commissioning test procedures cover the following parameters:

1. HEPA filter integrity by DOP testing for pinhole leaks in the filter media, across sealants and frame gaskets, supporting frame and wall.
2. Air stream velocity under each filter panel. Airflow measurements should be made at supply, return and exhaust outlets, as well as traverses across the face of hoods, to verify proper flows and capture patterns.
3. Establish a spectrum of particulates from appropriate air samples.
4. Smoke testing for establishing flow patterns if possible and if required similar test are desirable with the cleanroom in operation and at rest for a complete validation.
5. Pressure differentials between rooms to passage to change rooms.
6. Pressure drop across the final filters.
7. Room temperatures and relative humidity. Temperature and humidity sensors at critical areas should also be checked for accuracy at this time by actually reading space conditions and checking against values reported by the BMS.
8. A comprehensive documentation of the testing procedures and test readings is prepared before the facility is handed over for production.

For proper evaluation of the facility, the system should be tested while at rest, and during production.

VALIDATION

NO production can start until the cleanroom is validated.

When a pharmaceutical facility is to be validated, the validating agency will peruse the HVAC documentation and should communicate with the design engineers to establish the validation protocol as it relates to the HVAC system. If the design is proper, the system is properly installed, and the components perform as specified, the systems should be easily validatable. The validator will follow a master plan and protocols to verify the actual system installation and operation against design values and intent. The physical parameters reported by the BMS system shall be verified by measurements using calibrated instruments to verify accuracy.

DOCUMENTATION

Good manufacturing practices govern the level of control of various parameters for quality assurance, regulating the acceptance criteria, validation of the facility, and documentation for operation and maintenance. The documentation should cover design, operation and performance qualifications of the system.

Design Qualification

The design qualification document should cover all the following issues:

1. Identification of various systems, their functions, schematics & flow diagrams, sensors, dampers valves etc., critical parameters & fail-safe positions.
2. Layout plans showing various rooms & spaces and the critical parameters like:
 - Room temperature
 - room humidity
 - Room pressures and differential pressures between room and room and passages
 - Process equipment locations and power inputs
 - Critical instruments, recorders and alarms, if any

3. Equipment performance and acceptance criteria for fans, filters, cooling coils, heating coils, motors & drives.
4. Duct & pipe layouts showing air inlets, outlets air quantities, water flows and pressures.
5. Control schematics and control procedures.

Operation Qualification

This is a commissioning documentation which shall provide all the details of equipment various points of performance, test readings, statement of compliance and noncompliance with the acceptance criteria. Broadly the features are as follows:

1. Installation date showing manufacturers, model no., ratings of all equipment such as fans, motors, cooling & reheat coils, filters, HEPA filters, controls etc.
2. As-built drawings showing equipment layouts, duct and pipe runs, control & fire dampers, settings of various sensors and controllers.
3. Contractor's test readings covering rotation tests, megger readings, air quantities, temperatures and RH pressures of each space, dry & wet run of controls, air and water balance, HEPA filter integrity tests at final operating velocities testing of limits & alarms.
4. Identification of items spaces, parameters not meeting the acceptance criteria but cannot be corrected.

Performance Qualification

This is essentially for the system operating under full production conditions and covers among others:

1. Identification of agency for commissioning, for equipment and instruments and their calibration.

2. Test readings of all critical parameters under full operating conditions and full production, modification of readings in the contractors test results, acceptable and unacceptable departures from design qualification and acceptance criteria.

SUMMARY

HVAC systems in manufacturing portions of facilities are closely supervised by the FDA and must meet other global current good manufacturing practices (cGMP's). Per US GMP, Design and Construction Features Standard (211.42), sterile area cleanrooms have the following distinct characteristics:

1. Air should be of a high microbial quality.
2. Air handling system is provided with a central HEPA filter bank along with mandatory terminal filters in order to extend the life of terminal filters.
3. The filtration regime is generally three stages with two stages of pre-filters, 10 micron (EU 4), 3 micron (EU 8) and one central final filter 0.3 micron (EU 12) along with terminal HEPA filter.
4. All sterile critical operations shall be in a laminar flow work station.
5. Critical areas should have a positive pressure differential relative to adjacent LESS clean areas: a positive pressure differential of 0.05 inch of water (12.5 Pa) is acceptable.
6. Supply air outlets are provided flush at the ceiling level with perforated stainless steel grilles and terminal absolute filters. Return air grilles to be provided at the floor level with a return air riser for better scavenging
7. Walls, floors, and ceilings for cGMP areas are to be constructed of smooth, cleanable surfaces, impervious to sanitizing solutions and resistant to chipping, flaking, and oxidizing.

Maintaining proper pressurization gradient between adjacent spaces is important to prevent infiltration and cross-contamination. Air filtration techniques and air conditioning components shall be constantly monitored and upgraded in order to improve the finished product and reduce energy consumption.

Remember, overstating quality requirements and tolerances may result in unnecessary costs. Higher air flows and pressures require more HVAC capacity. Since most engineering decisions will have an impact on HVAC systems, it is important to recognize opportunities to seek the best engineering solutions.
