



PDHonline Course M338 (5 PDH)

Fluid Power Systems (Part 3) – Hydraulic Components

Instructor: A. Bhatia, B.E.

2020

PDH Online | PDH Center

5272 Meadow Estates Drive
Fairfax, VA 22030-6658
Phone: 703-988-0088
www.PDHonline.com

An Approved Continuing Education Provider

Naval Education and
Training Command

NAVEDTRA 12964
July 1990
0502-LP-213-2300

Training Manual
(TRAMAN)



Fluid Power

DISTRIBUTION STATEMENT A: Approved for public release; distribution is unlimited.

Nonfederal government personnel wanting a copy of this document must use the purchasing instructions on the inside cover.



0502LP2132300

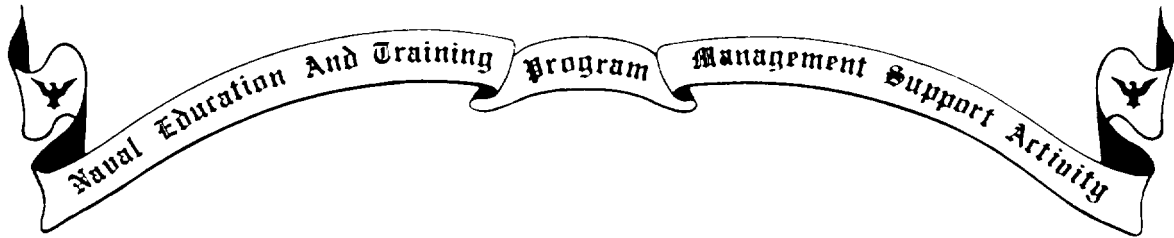

FLUID POWER

NAVEDTRA 12964

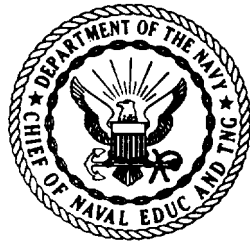

*1990 Edition Prepared by
MWC Albert Beasley, Jr.*



CHAPTER 8

MEASUREMENT AND PRESSURE CONTROL DEVICES

For safe and efficient operation, fluid power systems are designed to operate at a specific pressure and/or temperature, or within a pressure and/or temperature range.

You have learned that the lubricating power of hydraulic fluids varies with temperature and that excessively high temperatures reduce the life of hydraulic fluids. Additionally, you have learned that the materials, dimensions, and method of fabrication of fluid power components limit the pressure and temperature at which a system operates. You have also learned of means of automatically controlling pressure in both hydraulic and pneumatic systems.

Most fluid power systems are provided with pressure gauges and thermometers for measuring and indicating the pressure and/or the temperature in the system. Additionally, various temperature and pressure switches are used to warn of an adverse pressure or temperature condition. Some switches will even shut the system off when an adverse condition occurs. These devices will be discussed in this chapter.

PRESSURE GAUGES

Many pressure-measuring instruments are called gauges. However, this section will be restricted to two mechanical instruments that contain elastic elements that respond to pressures found in fluid power systems—the Bourdon-tube and bellows gauges.

BOURDON TUBE GAUGES

The majority of pressure gauges in use have a Bourdon-tube as a measuring element. (The gauge is named for its inventor, Eugene Bourdon, a French engineer.) The Bourdon tube is a device that senses pressure and converts the pressure to displacement. Since the Bourdon-tube displacement is a function of the pressure applied, it may be mechanically amplified and indicated by a

pointer. Thus, the pointer position indirectly indicates pressure.

The Bourdon-tube gauge is available in various tube shapes: curved or C-shaped, helical, and spiral. The size, shape, and material of the tube depend on the pressure range and the type of gauge desired. Low-pressure Bourdon tubes (pressures up to 2000 psi) are often made of phosphor bronze. High-pressure Bourdon tubes (pressures above 2000 psi) are made of stainless steel or other high-strength materials. High-pressure Bourdon tubes tend to have more circular cross sections than their lower-range counterparts, which tend to have oval cross sections. The Bourdon tube most commonly used is the C-shaped metal tube that is sealed at one end and open at the other (fig. 8-1).

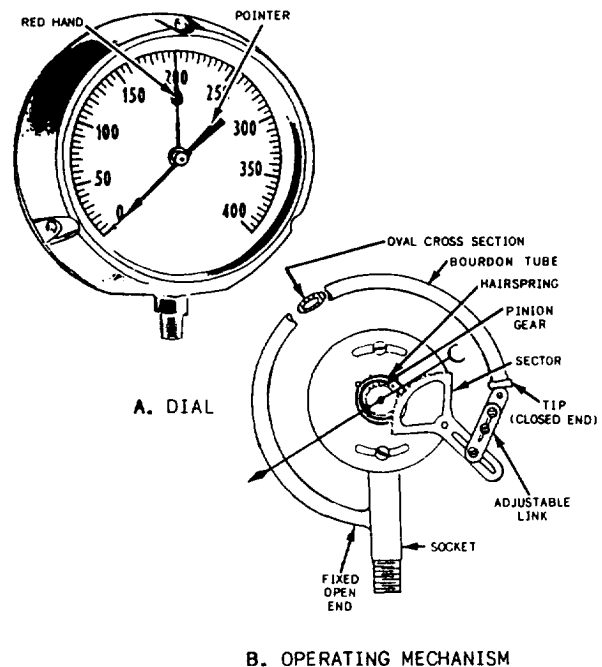

Figure 8-1.—Simplex Bourdon-tube pressure gauge.

C-shaped Bourdon Tube

The C-shaped Bourdon tube has a hollow, elliptical cross section. It is closed at one end and is connected to the fluid pressure at the other end. When pressure is applied, its cross section becomes more circular, causing the tube to straighten out, like a garden hose when the water is first turned on, until the force of the fluid pressure is balanced by the elastic resistance of the tube material. Since the open end of the tube is anchored in a fixed position, changes in pressure move the closed end. A pointer is attached to the closed end of the tube through a linkage arm and a gear and pinion assembly, which rotates the pointer around a graduated scale.

Bourdon-tube pressure gauges are often classified as simplex or duplex, depending upon whether they measure one pressure or two pressures. A simplex gauge has only one Bourdon tube and measures only one pressure. The pressure gauge shown in figure 8-1 is a simplex gauge. A red hand is available on some gauges. This hand is manually positioned at the maximum operating pressure of the system or portion of the system in which the gauge is installed.

When two Bourdon tubes are mounted in a single case, with each mechanism acting

independently but with the two pointers mounted on a common dial, the assembly is called a duplex gauge. Figure 8-2 shows a duplex gauge with views of the dial and the operating mechanism. Note that each Bourdon tube has its own pressure connection and its own pointer. Duplex gauges are used to give a simultaneous indication of the pressure from two different locations. For example, it may be used to measure the inlet and outlet pressures of a strainer to obtain the differential pressure across it.

Differential pressure may also be measured with Bourdon-tube gauges. One kind of Bourdon-tube differential pressure gauge is shown in figure 8-3. This gauge has two Bourdon tubes but only one pointer. The Bourdon tubes are connected in such a way that they indicate the pressure difference, rather than either of two actual pressures.

As mentioned earlier, Bourdon-tube pressure gauges are used in many hydraulic systems. In this application they are usually referred to as hydraulic gauges. Bourdon-tube hydraulic gauges are not particularly different from other types of Bourdon-tube gauges in how they operate; however, they do sometimes have special design features because of the extremely high system pressures to which they may be exposed. For

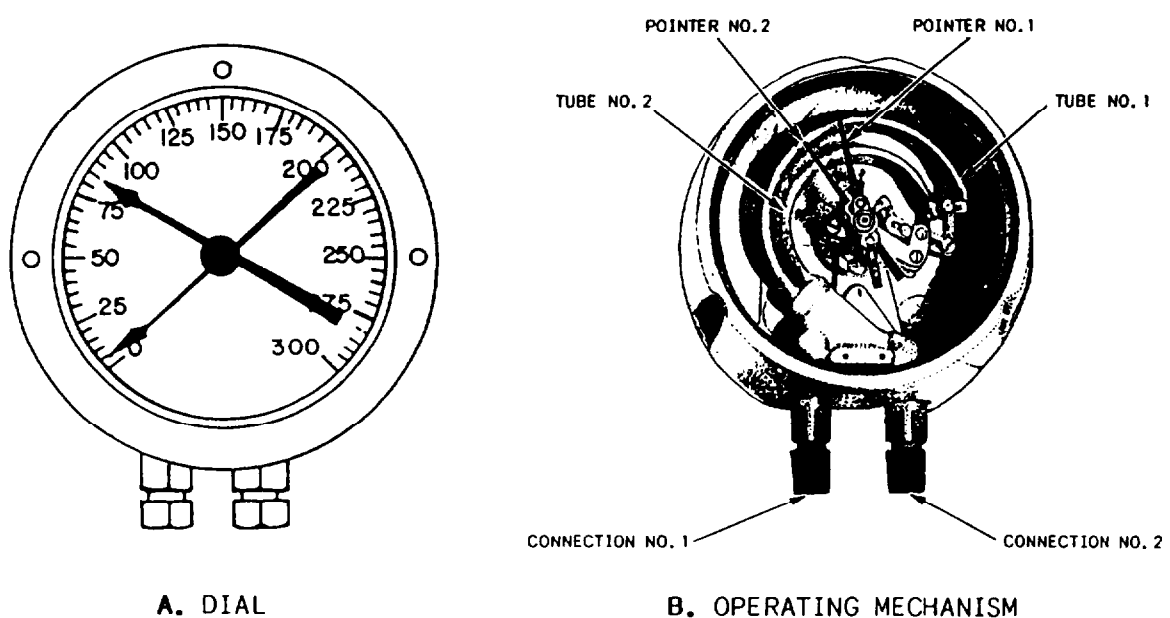
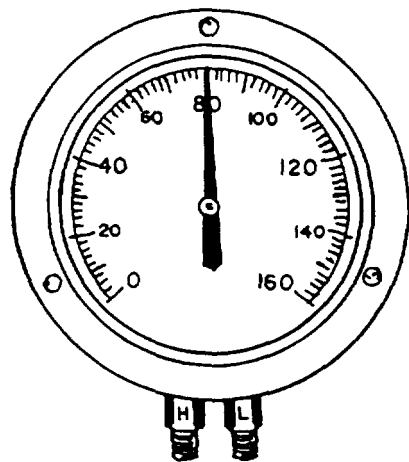
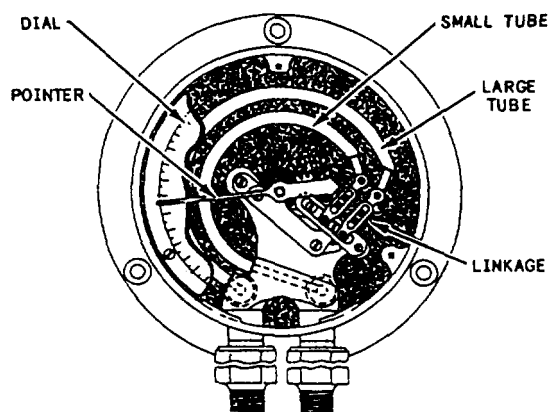

Figure 8-2.—Duplex Bourdon-tube pressure gauge.



A. DIAL



B. OPERATING MECHANISM

Figure 8-3.—Bourdon-tube differential pressure gauge.

example, some hydraulic gauges have a special type of spring-loaded linkage that is capable of taking overpressure and underpressure without damage to the movement and that keeps the pointer from slamming back to zero when the pressure is suddenly changed. A hydraulic gauge that does not have such a device must be protected by a suitable check valve. Some hydraulic gauges may also have special dials that indicate both the pressure (in psi) and the corresponding total force being applied, for example tons of force produced by a hydraulic press.

Spiral and Helical Bourdon Tubes

Spiral and helical Bourdon tubes (figs. 8-4 and 8-5) are made from tubing with a flattened cross

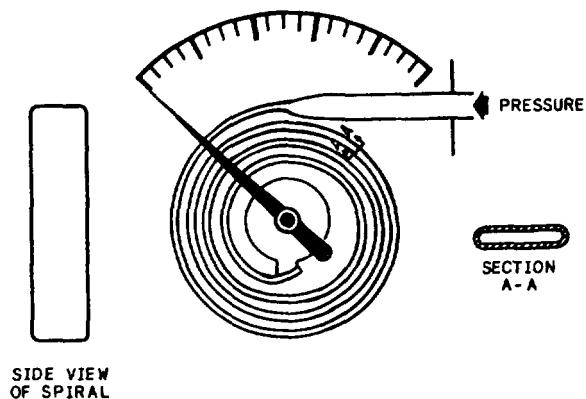

Figure 8-4.—Spiral Bourdon tube.

section. Both were designed to provide more travel of the tube tip, primarily for moving the recording pen of pressure recorders.

BELLOWS ELASTIC ELEMENTS

A bellows elastic element is a convoluted unit that expands and contracts axially with changes in pressure. The pressure to be measured can be applied to either the outside or the inside of the bellows; in practice, most bellows measuring

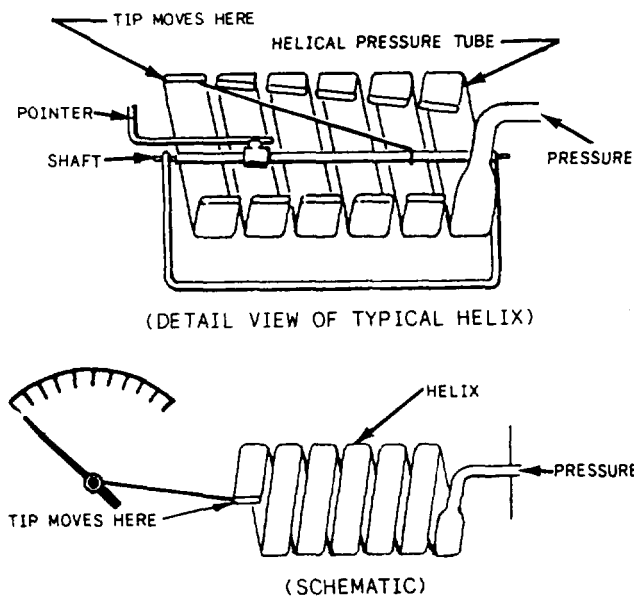

Figure 8-5.—Helical Bourdon tube.

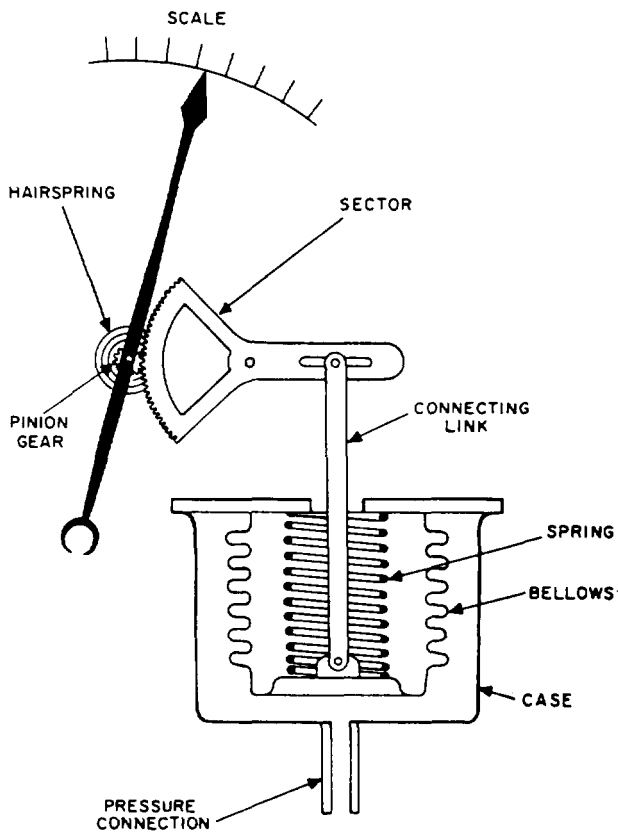

Figure 8-6.—Simple bellows gauge.

devices have the pressure applied to the outside of the bellows (fig. 8-6).

Simple Bellows Elements

Bellows elastic elements are made of brass, phosphor bronze, stainless steel, beryllium-copper, or other metal suitable for the intended service of the gauge. Motion of the element (bellows) is transmitted by suitable linkage and gears to a dial pointer. Most bellows gauges are spring-loaded—that is, a spring opposes the bellows and thus prevents full expansion of the bellows. Limiting the expansion of the bellows in this way protects the bellows and prolongs its life. Because of the elasticity in both the bellows and the spring in a spring-loaded bellows element, the relationship between the applied pressure and bellows movement is linear.

Dual Bellows Indicators

Another type of bellows element is the dual-bellows element. Figure 8-7 is a schematic diagram of this indicator. Dual-bellows element pressure indicators are used throughout the Navy as flow-measuring, level-indicating, or pressure-indicating devices.

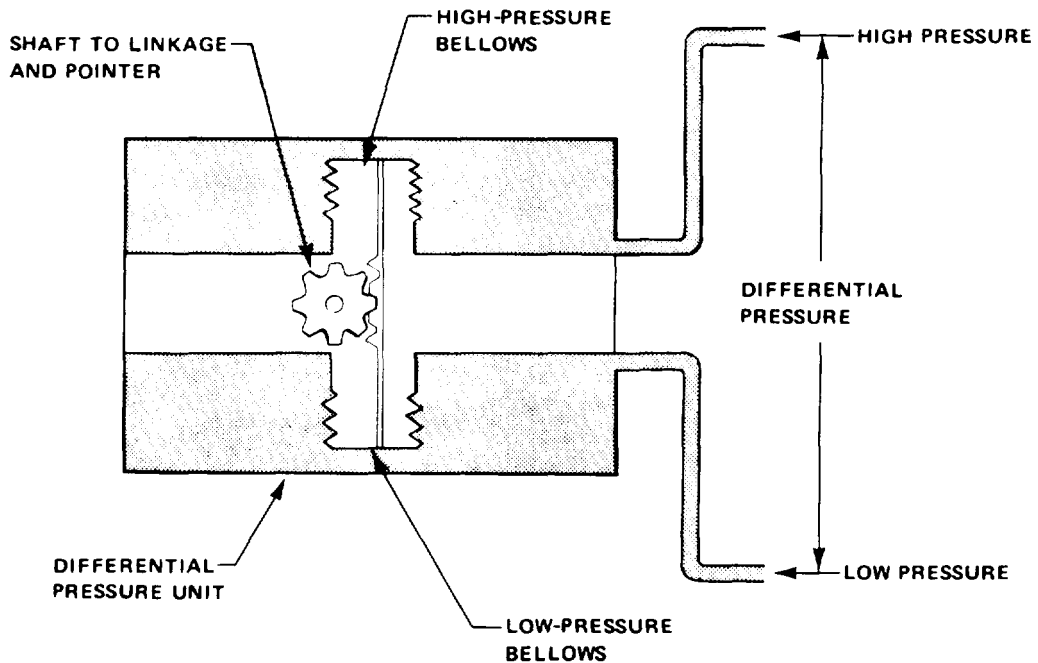

Figure 8-7.—Differential pressure sensor dual bellows.

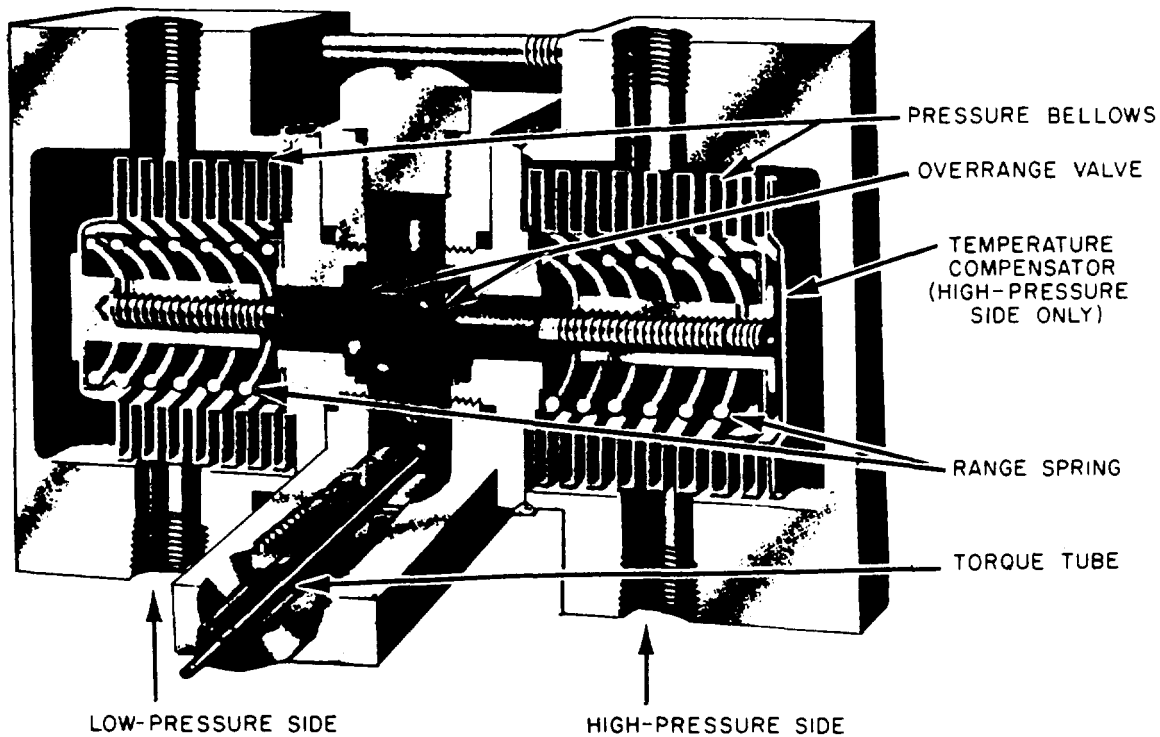

Figure 8-8.—Dual bellows assembly.

When in operation, the bellows will move in proportion to the difference in pressure applied across the bellows unit assembly. The linear motion of the bellows is picked up by a drive arm and transmitted as a rotary motion through a torque tube assembly (fig. 8-8). The indicating mechanism multiplies rotation of the torque tube through a gear and pinion to the indicating pointer.

Bellows elements are used in various applications where the pressure-sensitive device must be powerful enough to operate not only the indicating pointer but also some type of recording device.

PRESSURE SWITCHES

Often when a measured pressure reaches a certain maximum or minimum value, it is desirable to have an alarm sound a warning, a light to give a signal, or an auxiliary control system to energize or de-energize. A pressure switch is the device commonly used for this purpose.

One of the simplest pressure switches is the single-pole, single-throw, quick-acting type shown in figure 8-9. This switch is contained in a metal

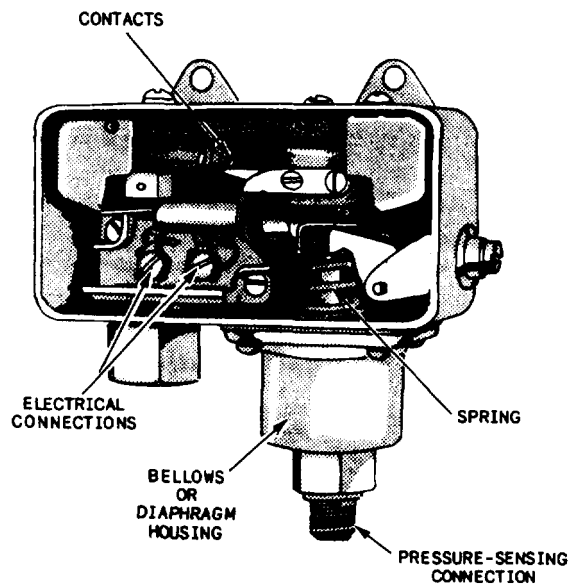

Figure 8-9.—Typical pressure switch.

case that has a removable cover, an electrical connection, and a pressure-sensing connection. The switch contains a seamless metallic bellows located in its housing. Changes in the measured pressure causes the bellows to work against an adjustable spring. This spring determines the pressure required to actuate the switch. Through suitable linkage, the spring causes the contacts to open or close the electrical circuit automatically when the operating pressure falls below or rises above a specified value. A permanent magnet in the switch mechanism provides a positive snap on both the opening and closing of the contacts. The switch is constantly energized. However, it is the closing of the contacts that energizes the entire electrical circuit.

Another pressure switch is an electric-hydraulic assembly that is used for shutting off the pump's motor whenever the system pressure exceeds a pre-determined maximum value (fig. 8-10). The switch is mounted on the pump housing so that the former's low pressure ports drain directly into the pump housing.

This pressure switch principally consists of a flange-mounted hydraulic valve to which is fixed a normally closed electrical limit switch.

The valve consists of two hydraulically interconnected components, the pilot valve sub-assembly, which bolts on the bottom of the body (1), functions to sense system pressure continuously and initiates pressure switch action whenever this pressure exceeds the adjusted setting of the pilot adjustment. System pressure is directed into the bottom port and is applied against the exposed tip of the pilot piston (5). This piston is held on its seat by compression from the piston spring (6) which is dependent on the position of the adjusting screw (8). Whenever the pressure causes a force sufficiently large enough to raise the pilot piston from its seat, fluid flows through an interconnecting passage to the actuating piston (2) chamber. The accompanying fluid force raises the actuating piston against the force of spring 3 and causes depression of the extended switch plunger. This, in turn, disconnects the contained electrical switch, which may be connected into the pump motor's electric supply system.

Pressure switches come in many sizes and configurations depending on how they will be used.

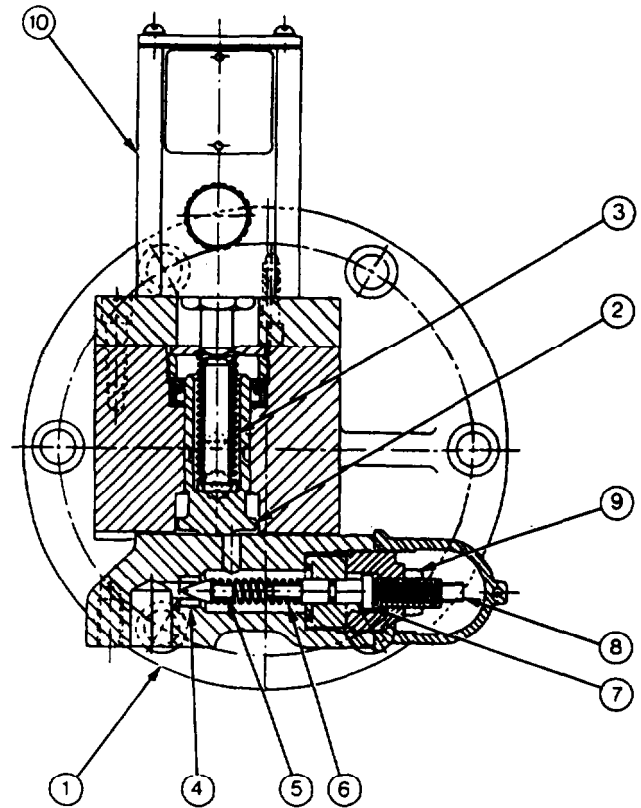

- | | |
|---------------------|-----------------------------|
| 1. Body | 6. Piston Spring |
| 2. Actuating Piston | 7. Plunger-Adjustment Screw |
| 3. Spring | 8. Adjusting Screw |
| 4. Seat | 9. Adjusting Screw Lock Nut |
| 5. Pilot Piston | 10. Limit Switch |

Figure 8-10.—Electric-hydraulic pressure switch.

TEMPERATURE-MEASURING INSTRUMENTS

Temperature is the degree of hotness or coldness of a substance measured on a definite scale. Temperature is measured when a measuring instrument, such as a thermometer, is brought into contact with the medium being measured.

All temperature-measuring instruments use some change in a material to indicate temperature. Some of the effects that are used to indicate temperature are changes in physical properties and altered physical dimensions. One of the more important physical properties used in temperature-measuring instruments is the change in the length of a material in the form of expansion and contraction.

Consider the uniform homogeneous bar illustrated in figure 8-11. If the bar has a given

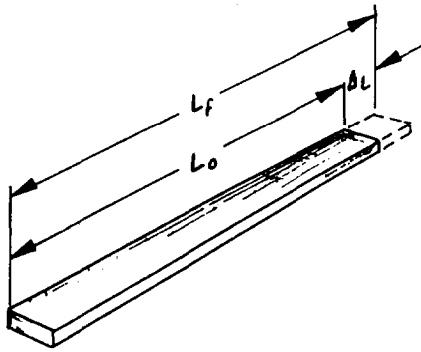

Figure 8-11.—Expansion of a bar.

length (L_o) at some temperature and is heated, it will expand (L_f). The amount of expansion (ΔL) is a function of the original length and the temperature increase. The amount a material changes in length with temperature is called the linear coefficient of expansion.

The linear coefficient of expansion for a material is a physical property of that material and describes its behavior with respect to temperature.

BIMETALLIC EXPANSION THERMOMETER

If two materials with different linear coefficients are bonded together, as the temperature changes their rate of expansion will be different. This will cause the entire assembly to bend in an arc as shown in figure 8-12.

When the temperature is raised, an arc is formed around the material with the smaller expansion coefficient. Since this assembly is formed by joining two dissimilar materials, it is known as a bimetallic element.

A modification of this bimetallic strip serves as the basis for one of the simplest and most commonly encountered temperature-measuring instruments, the bimetallic thermometer.

Figure 8-13 shows a bimetallic thermometer. In it, a bimetallic strip is wound in the form of a long helix. One end of the helix is held rigid. As the temperature varies, the helix tries to wind or unwind. This causes the free end to rotate. The

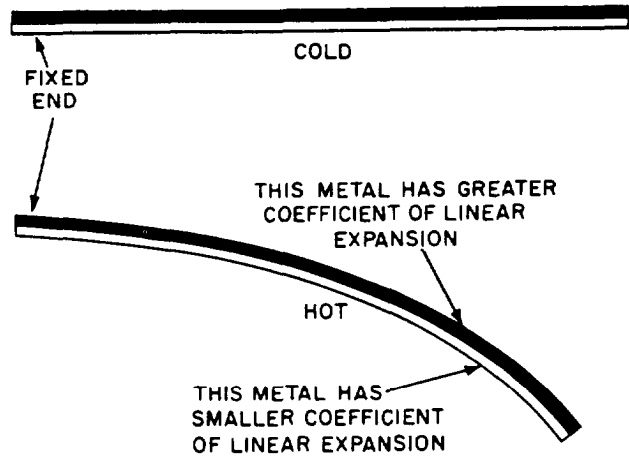

Figure 8-12.—Effect of unequal expansion of a bimetallic strip.

free end is connected to a pointer. The pointer actually indicates angular rotation of the helix; however, since the rotation is linear and a function of temperature, the scale is marked in units of temperature.

DISTANT-READING THERMOMETERS

Distant-reading dial thermometers are used when the indicating portion of the instrument must be placed at a distance from where the temperature is being measured. The distant-reading thermometer has a long capillary, some

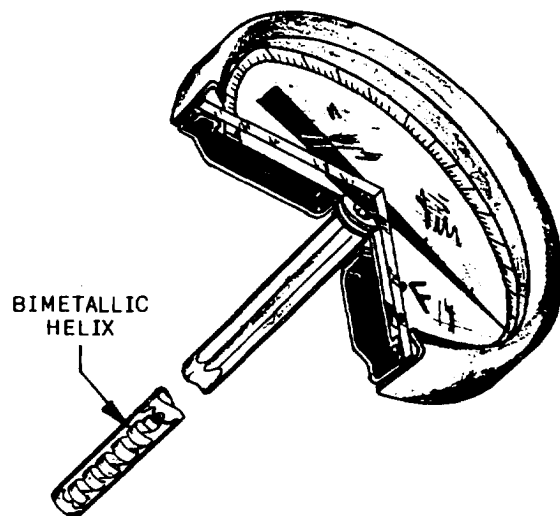

Figure 8-13.—Bimetallic thermometer.

as long as 125 feet, which separates the sensing bulb from the Bourdon tube and dial (fig. 8-14).

There are three basic types of distant-reading thermometers: the liquid filled, the gas filled, and the combination liquid-vapor filled. The thermometers are filled with fluid (liquid or gas) at some temperature and sealed. Almost the entire volume of the fluid is in the sensing bulb.

As the temperature of the bulb changes, the volume of the fluid tries to change. Since the volume of the thermometer (sensing bulb, capillary, and Bourdon tube) is constant, a pressure change occurs within the thermometer. This pressure change causes the Bourdon tube to straighten out (with an increase in pressure), working a system of levers and gears, which causes the thermometer pointer to move over the dial and register temperature.

TEMPERATURE SWITCHES

Temperature switches operate from temperature changes occurring in an enclosure, or in the air surrounding the temperature-sensing element. The operation of the temperature switch is similar to the operation of the pressure switch shown in figure 8-9; both switches are operated by changes in pressure. The temperature element is arranged so a change in temperature causes a change in the internal pressure of a sealed-gas or air-filled bulb

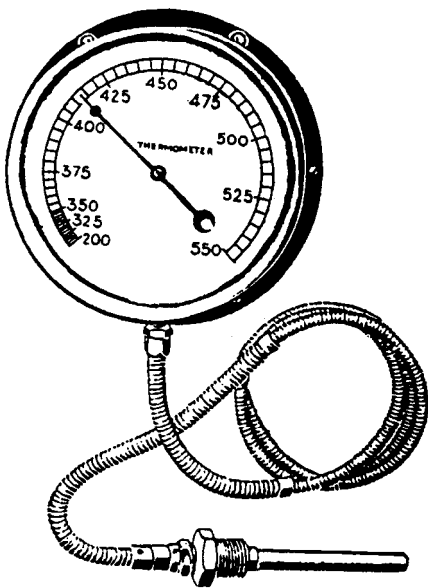

Figure 8-14.—Distant-reading, Bourdon-tube thermometers.

or helix, which is connected to the actuating device by a small tube or pipe. Figure 8-15 shows a temperature switch and two types of sensing elements.

A temperature change causes a change in the volume of the sealed-in gas, which causes movement of a bellows. The movement is transmitted by a plunger to the switch arm. The moving contact is on the arm. A fixed contact may be arranged so the switch will open or close on a temperature rise. This allows the switch contacts to be arranged to close when the temperature drops to a predetermined value and to open when the temperature rises to the desired value. The reverse action can be obtained by a change in the contact positions.

GAUGE SNUBBERS

The irregularity of impulses applied to the fluid power system by some pumps or air compressors causes the gauge pointer to oscillate violently. This makes reading of the gauge not only difficult but often impossible. Pressure oscillations and other sudden pressure changes existing in fluid power systems will also affect the delicate internal mechanism of gauges and cause either damage to or complete destruction of the

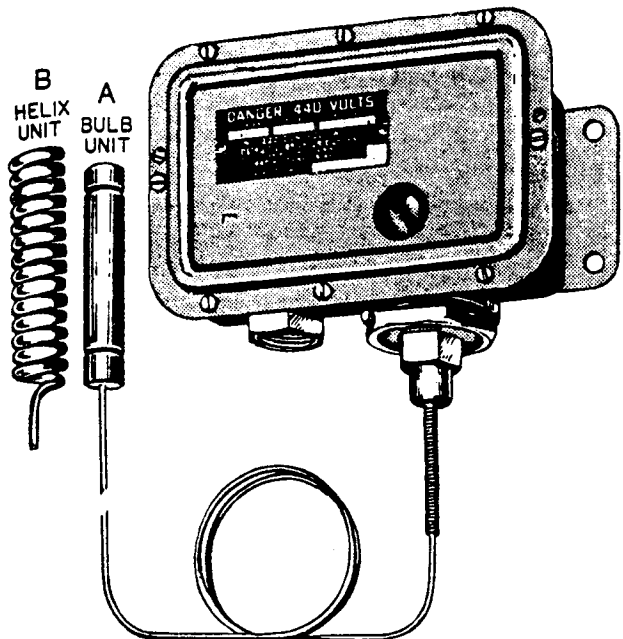

Figure 8-15.—Temperature switch with two types of sensing elements. A. Bulb unit. B. Helix unit.

gauge. A pressure gauge snubber is therefore installed in the line that leads to the pressure gauge.

The purpose of the snubber is to dampen the oscillations and thus provide a steady reading and protection for the gauge. The basic components of a snubber are the housing, fitting assembly with a fixed orifice diameter, and a pin and plunger assembly (fig. 8-16). The snubbing action is obtained by metering fluid through the snubber. The fitting assembly orifice restricts the amount of fluid that flows to the gauge, thereby snubbing the force of a pressure surge. The pin is pushed and pulled through the orifice of the fitting assembly by the plunger, keeping it clean and at a uniform size.

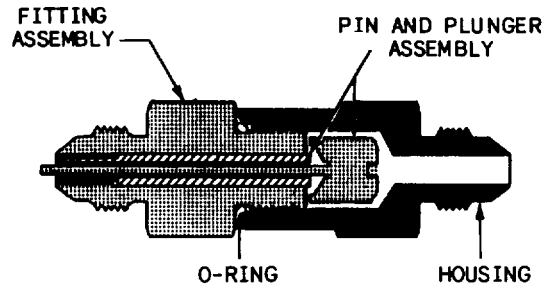

Figure 8-16.—Pressure gauge snubber.

CHAPTER 9

RESERVOIRS, STRAINERS, FILTERS, AND ACCUMULATORS

Fluid power systems must have a sufficient and continuous supply of uncontaminated fluid to operate efficiently. As stated in chapter 3 and emphasized throughout this manual, the fluid must be kept free of all foreign matter.

This chapter covers hydraulic reservoirs, various types of strainers and filters, and accumulators installed in fluid power systems.

RESERVOIRS

A hydraulic system must have a reserve of fluid in addition to that contained in the pumps, actuators, pipes, and other components of the system. This reserve fluid must be readily available to make up losses of fluid from the system, to make up for compression of the fluid under pressure, and to compensate for the loss of volume as the fluid cools. This extra fluid is contained in a tank usually called a reservoir. A reservoir may sometimes be referred to as a sump tank, service tank, operating tank, supply tank, or base tank.

In addition to providing storage for the reserve fluid needed for the system, the reservoir acts as a radiator for dissipating heat from the fluid and as a settling tank where heavy particles of contamination may settle out of the fluid and remain harmlessly on the bottom until removed by cleaning or flushing of the reservoir. Also, the reservoir allows entrained air to separate from the fluid.

Most reservoirs have a capped opening for filling, an air vent, an oil level indicator or dip stick, a return line connection, a pump inlet or suction line connection, a drain line connection, and a drain plug (fig. 9-1). The inside of the reservoir generally will have baffles to prevent excessive sloshing of the fluid and to put a partition between the fluid return line and the pump suction or inlet line. The partition forces the returning fluid to travel farther around the tank before being drawn back into the active

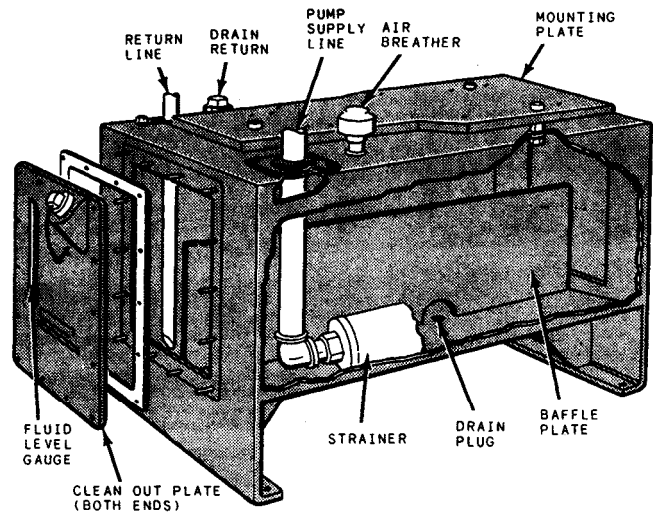

Figure 9-1.—Nonpressurized reservoir (ground or ship installation).

system through the pump inlet line. This aids in settling the contamination and separating the air from the fluid.

Large reservoirs are desirable for cooling. A large reservoir also reduces recirculation which helps settle contamination and separate air. As a “thumb rule,” the ideal reservoir should be two to three times the pump output per minute. However, due to space limitations in mobile and aerospace systems, the benefits of a large reservoir may have to be sacrificed. But, they must be large enough to accommodate thermal expansion of the fluid and changes in fluid level due to system operation. Reservoirs are of two general types—nonpressurized and pressurized.

NONPRESSURIZED RESERVOIRS

Hydraulic systems designed to operate equipment at or near sea level are normally equipped with nonpressurized reservoirs. This includes the hydraulic systems of ground and ship

installations. A typical reservoir for use with ground and ship installations is shown in figure 9-1. This type of reservoir is made of hot rolled steel plates and has welded seams. The ends extend below the bottom of the reservoir and serve as supports. The bottom of the reservoir is convex, and a drain plug is incorporated at the lowest point.

Nonpressurized reservoirs are also used in several transport-, patrol-, and utility-type aircraft. These aircraft are not designed for violent maneuvers and, in some cases, do not fly at high altitude. Those aircraft that have nonpressurized reservoirs installed and that fly at high altitudes have the reservoirs installed within a pressurized area. (High altitude in this situation means an altitude where atmospheric pressure is inadequate to maintain sufficient flow of fluid to the hydraulic pumps.)

Most nonpressurized aircraft reservoirs are constructed in a cylindrical shape (fig. 9-2). The outer housing is manufactured from a strong corrosion-resistant metal. Filter elements are normally installed internally within the reservoir to clean returning system hydraulic fluid. Some of the older aircraft have a filter bypass valve installed to allow fluid to bypass the filter if the filter becomes clogged. Reservoirs that are filled by pouring fluid directly into them have a filler (finger) strainer assembly installed in the filler well to strain out impurities as the fluid enters the reservoir.

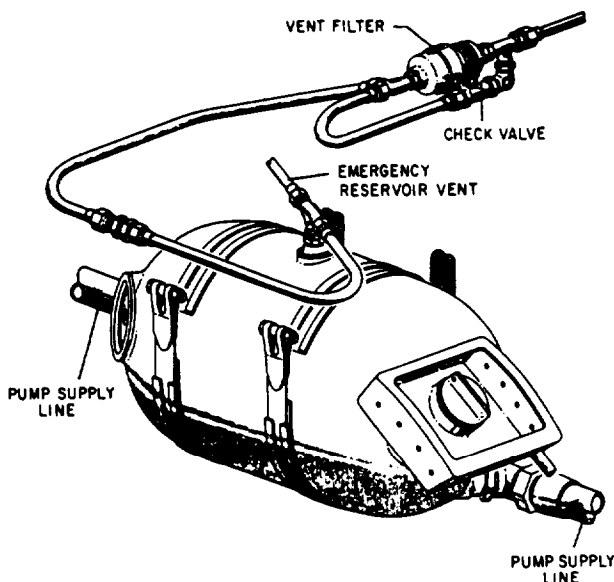

Figure 9-2.—Nonpressurized aircraft reservoir.

The quantity of fluid in the reservoir is indicated by either a glass tube, a directing gauge, or a float-type rod, which is visible through a transparent dome installed on the reservoir.

PRESSURIZED RESERVOIRS

A pressurized reservoir is required in hydraulic systems where atmospheric pressure is insufficient to maintain a net positive suction head (NPSH) to the pump. There are two common types of pressurized reservoirs—fluid-pressurized and air-pressurized.

Fluid-Pressurized Reservoir

Some aircraft hydraulic systems use fluid pressure for pressurizing the reservoir. The reservoir shown in figure 9-3 is of this type. This reservoir is divided into two chambers by a floating piston. The piston is forced downward in the reservoir by a compression spring within the pressurizing cylinder and by system pressure entering the pressurizing port of the cylinder.

The pressurizing port is connected directly to the pressure line. When the system is pressurized, pressure enters the pressure port, thus pressurizing the reservoir. This pressurizes the pump suction line and the reservoir return line to the same pressure.

The reservoir shown in figure 9-3 has five ports—pump suction, return, pressurizing, overboard drain, and bleed. Fluid is supplied to the pump through the pump suction port. Fluid returns to the reservoir from the system through the return port. Pressure from the pump enters the pressurizing cylinder in the top of the reservoir through the pressurizing port. The overboard drain port is used to drain the reservoir while performing maintenance, and the bleed port is used as an aid when servicing the reservoir.

Air-Pressurized Reservoirs

Air-pressurized reservoirs, such as the one shown in figure 9-4, are currently used in many high-performance naval aircraft. The reservoir is cylindrical in shape and has a piston installed internally to separate the air and fluid chambers. Air pressure is usually provided by engine bleed air. The piston rod end protrudes through the reservoir end cap and indicates the fluid quantity. The quantity indication may be seen by inspecting the distance the piston rod protrudes from the reservoir end cap. The reservoir is provided with

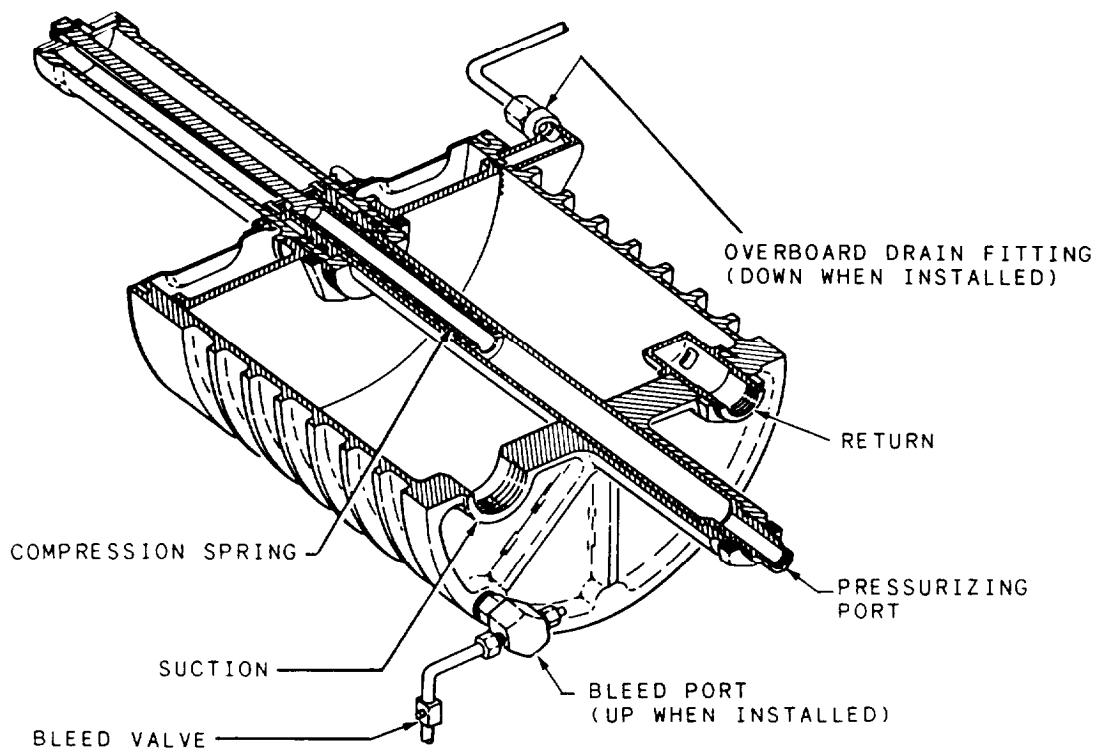

Figure 9-3.—Typical fluid-pressurized reservoir.

threaded openings for connecting fittings and components. Figure 9-4 shows several components installed in lines leading to and from the reservoir; however, this may not be the case in actual installation. The air relief valve, bleeder valve, and soon, may be reinstalled directly on the reservoir.

Because the reservoir is pressurized, it can normally be installed at any altitude and still maintain a positive flow of fluid to the pump.

Some air-pressurized reservoirs also have direct contact of fluid to gas. These reservoirs are installed in large systems and may be cylindrical or rectangular in shape. They contain an oil level indicator, a pump inlet or suction line connection, a return line, a gas pressurization and venting connection, and a drain line connection or a drain plug. These reservoirs are pressurized by air from the ship's service air system or nitrogen banks. These reservoirs are found on board aircraft carriers and submarines.

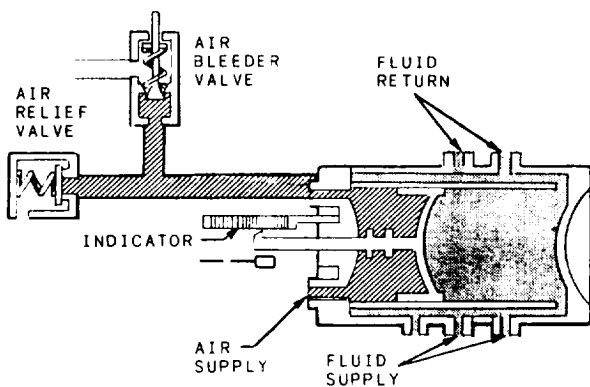

Figure 9-4.—Air-pressurized reservoir.

ACCUMULATORS

An accumulator is a pressure storage reservoir in which hydraulic fluid is stored under pressure from an external source. The storage of fluid under pressure serves several purposes in hydraulic systems.

In some hydraulic systems it is necessary to maintain the system pressure within a specific pressure range for long periods of time. It is very difficult to maintain a closed system without some leakage, either external or internal. Even a small leak can cause a decrease in pressure. By using an accumulator, leakage can be compensated for

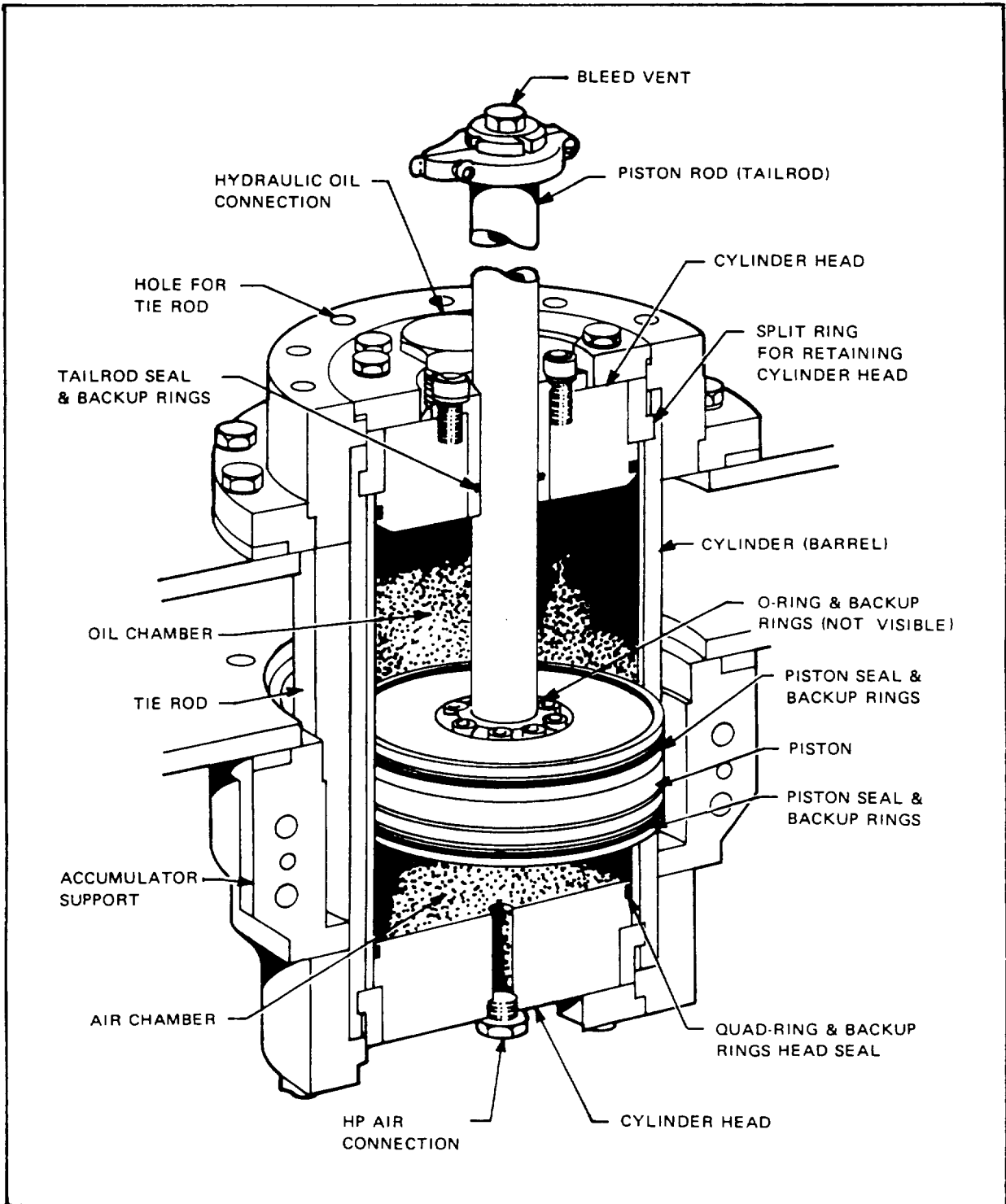

Figure 9-5.-Cross-section view of a piston-type accumulator with a tailrod.

and the system pressure can be maintained within an acceptable range for long periods of time. Accumulators also compensate for thermal expansion and contraction of the liquid due to variations in temperature.

A liquid, flowing at a high velocity in a pipe will create a backward surge when stopped suddenly by the closing of a valve. This sudden stoppage causes instantaneous pressures two to three times the operating pressure of the system. These pressures, or shocks, produce objectional noise and vibrations which can cause considerable damage to piping, fittings, and components. The incorporation of an accumulator enables such shocks and surges to be absorbed or cushioned by the entrapped gas, thereby reducing their effects. The accumulator also dampens pressure surges caused by pulsating delivery from the pump.

There are times when hydraulic systems require large volumes of liquid for short periods of time. This is due to either the operation of large cylinders or the necessity of operating two or more circuits simultaneously. It is not economical to install a pump of such large capacity in the system for only intermittent usage, particularly if there

is sufficient time during the working cycle for an accumulator to store up enough liquid to aid the pump during these peak demands.

The energy stored in accumulators may be also used to actuate hydraulically operated units if normal hydraulic system failure occurs.

Four types of accumulators used in Navy hydraulic systems are as follows:

1. Piston type
2. Bag or bladder type
3. Direct-contact gas-to-fluid type
4. Diaphragm type

PISTON-TYPE ACCUMULATORS

Piston-type accumulators consist of a cylindrical body called a barrel, closures on each end called heads, and an internal piston. The piston may be fitted with a tailrod, which extends through one end of the cylinder (fig. 9-5), or it may not have a tailrod at all (fig. 9-6). In the latter case, it is referred to as a floating piston. Hydraulic fluid is pumped into one end of the cylinder and the piston is forced toward the opposite end of the cylinder against a captive

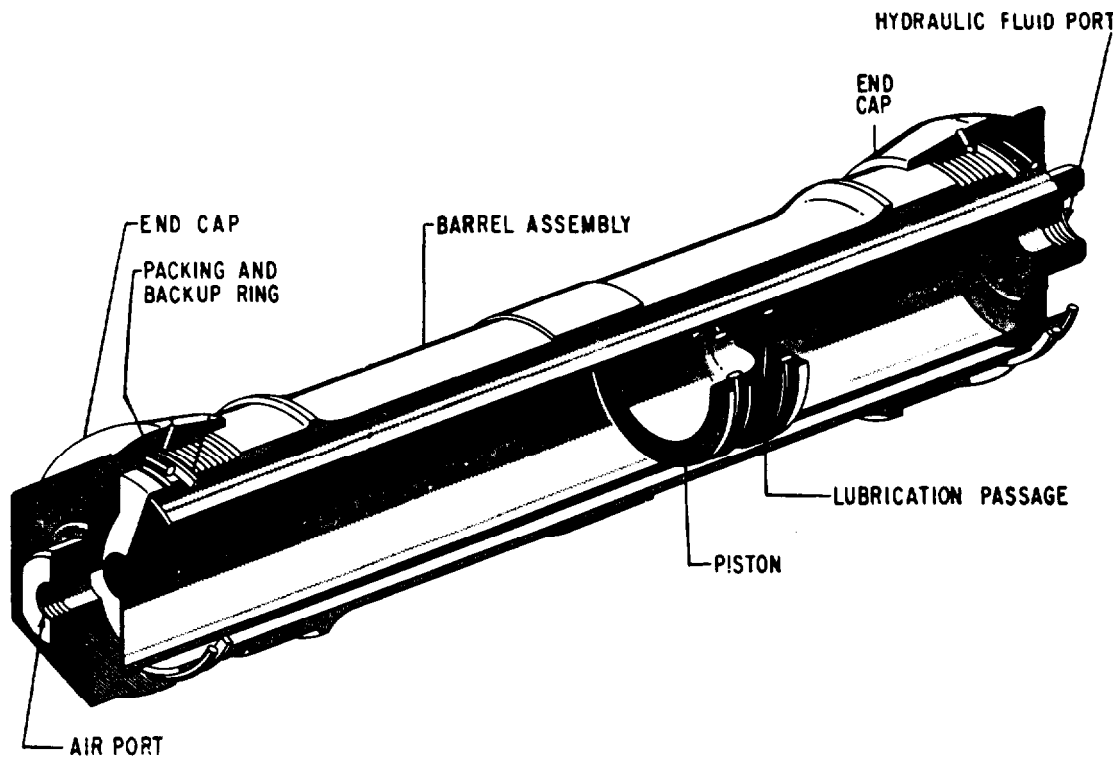

Figure 9-6.—Floating piston-type accumulator.

charge of air or an inert gas such as nitrogen. Sometimes the amount of air charge is limited to the volume within the accumulator; other installations may use separate air flasks which are piped to the air side of the accumulator. Piston accumulators may be mounted in any position.

The gas portion of the accumulator may be located on either side of the piston. For example, in submarine hydraulic systems with tailrod pistons, the gas is usually on the bottom and the fluid on top; in surface ships with floating pistons, the gas is usually on the top. The orientation of the accumulator and the type of accumulator are based upon such criteria as available space, maintenance accessibility, size, need for external monitoring of the piston's location (tailrod indication), contamination tolerance, seal life, and safety. The purpose of the piston seals is to keep the fluid and the gas separate.

Usually, tailrod accumulators use two piston seals, one for the air side and one for the oil side, with the space between them vented to the atmosphere through a hole drilled the length of the tailrod. When the piston seals fail in this type of accumulator, air or oil leakage is apparent. However, seal failure in floating piston or nonvented tailrod accumulators will not be as obvious. Therefore, more frequent attention to venting or draining the air side is necessary. An indication of worn and leaking seals can be detected by the presence of significant amounts of oil in the air side.

BLADDER-TYPE ACCUMULATORS

Bladder- or bag-type accumulators consist of a shell or case with a flexible bladder inside the shell. See figure 9-7. The bladder is larger in diameter at the top (near the air valve) and gradually tapers to a smaller diameter at the bottom. The synthetic rubber is thinner at the top of the bladder than at the bottom. The operation of the accumulator is based on Barlow's formula for hoop stress, which states: "The stress in a circle is directly proportional to its diameter and wall thickness." This means that for a certain thickness, a large diameter circle will stretch faster than a small diameter circle; or for a certain diameter, a thin wall hoop will stretch faster than a thick wall hoop. Thus, the bladder will stretch around the top at its largest diameter and thinnest wall thickness, and then will gradually stretch downward and push itself outward against the walls of the shell. As a result, the bladder is capable of squeezing out all the liquid from

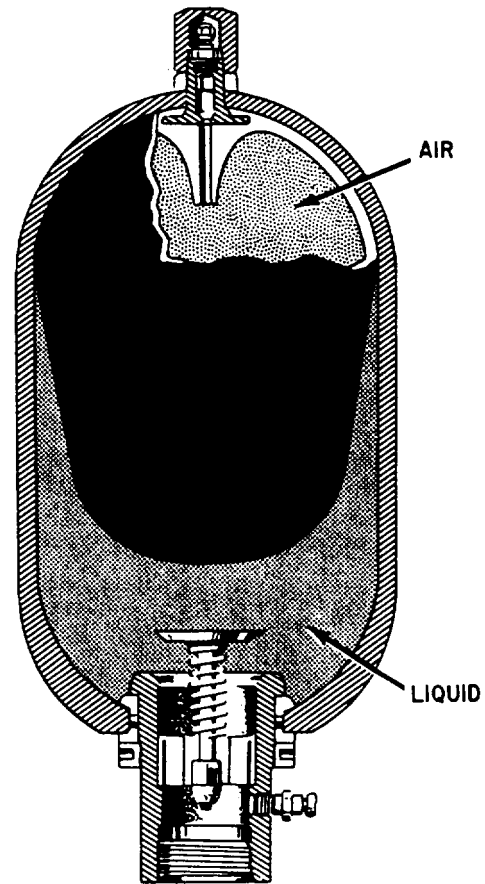

Figure 9-7.—Bladder-type accumulator.

the accumulator. Consequently, the bladder accumulator has a very high volumetric efficiency. In other words, this type of accumulator is capable of supplying a large percentage of the stored fluid to do work.

The bladder is precharged with air or inert gas to a specified pressure. Fluid is then forced into the area around the bladder, further compressing the gas in the bladder. This type of accumulator has the advantage that as long as the bladder is intact there is no exposure of fluid to the gas charge and therefore less danger of an explosion.

DIRECT-CONTACT GAS-TO-FLUID ACCUMULATORS

Direct-contact gas-to-fluid accumulators generally are used in very large installations where it would be very expensive to require a piston- or bladder-type accumulator. This type of accumulator consists of a fully enclosed cylinder, mounted in a vertical position, containing a liquid

port on the bottom and a pneumatic charging port at the top (fig. 9-8). This type of accumulator is used in some airplane elevator hydraulic systems where several thousand gallons of fluid are needed to supplement the output of the hydraulic pumps for raising the elevator platform. The direct contact between the air or gas and the hydraulic fluid tends to entrain excessive amounts of gas in the fluid. For this reason, direct contact accumulators are generally not used for pressures over 1200 psi. The use of this type of accumulator with flammable fluid is dangerous because there is a possibility of explosion if any oxygen is present in the gas, and pressure surges generate excessive heat. For this reason, safety fluids are used in this type of installation.

DIAPHRAGM ACCUMULATORS

The diaphragm-type accumulator is constructed in two halves which are either screwed or bolted together. A synthetic rubber diaphragm is installed between both halves, making two chambers. Two threaded openings exist in the assembled component. The opening at the top, as shown in figure 9-9, contains a screen disc which prevents the diaphragm from extruding through the threaded opening when system pressure is depleted, thus rupturing the diaphragm. On some designs the screen is replaced by a button-type protector fastened to the center

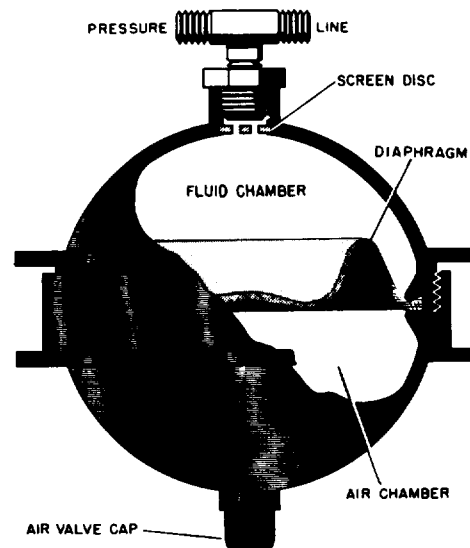

Figure 9-9.—Diaphragm accumulator.

of the diaphragm. An air valve for pressurizing the accumulator is located in the gas chamber end of the sphere, and the liquid port to the hydraulic system is located on the opposite end of the sphere. This accumulator operates in a manner similar to that of the bladder-type accumulator.

FILTRATION

You have learned that maintaining hydraulic fluids within allowable limits is crucial to the care and protection of hydraulic equipment. While every effort must be made to prevent contaminants from entering the system, contaminants which *do* find their way into the system must be removed. Filtration devices are installed at key points in fluid power systems to remove the contaminants that enter the system along with those that are generated during normal operations.

Filtration devices for hydraulic systems differ somewhat from those of pneumatic systems. Therefore, they will be discussed separately.

The filtering devices used in hydraulic systems are commonly referred to as strainers and filters. Since they share a common function, the terms *strainer* and *filter* are often used interchangeably. As a general rule, devices used to remove large particles of foreign matter from hydraulic fluids are referred to as strainers, while those used to remove the smallest particles are referred to as filters.

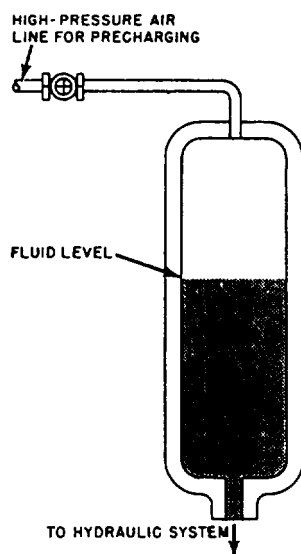

Figure 9-8.—Direct-contact gas-to-fluid accumulator.

STRAINERS

Strainers are used primarily to catch only very large particles and will be found in applications where this type of protection is required. Most hydraulic systems have a strainer in the reservoir at the inlet to the suction line of the pump. A strainer is used in lieu of a filter to reduce its chance of being clogged and starving the pump. However, since this strainer is located in the reservoir, its maintenance is frequently neglected. When heavy dirt and sludge accumulate on the suction strainer, the pump soon begins to cavitate. Pump failure follows quickly.

FILTERS

The most common device installed in hydraulic systems to prevent foreign particles and contamination from remaining in the system are referred to as filters. They may be located in the reservoir, in the return line, in the pressure line, or in any other location in the system where the designer of the system decides they are needed to safeguard the system against impurities.

Filters are classified as full flow and proportional or partial flow. In the full-flow type of filter, all the fluid that enters the unit passes through the filtering element, while in the proportional-flow type, only a portion of the fluid passes through the element.

Full-Flow Filter

The full-flow filter provides a positive filtering action; however, it offers resistance to flow, particularly when the element becomes dirty. Hydraulic fluid enters the filter through the inlet port in the body and flows around the filter element inside the filter bowl. Filtering takes place as the fluid passes through the filtering element and into the hollow core, leaving the dirt and impurities on the outside of the filter element. The filtered fluid then flows from the hollow core through the outlet port and into the system (fig. 9-10).

Some full-flow filters are equipped with a contamination indicator (fig. 9-11). These indicators, also known as differential pressure indicators, are available in three types—gauge indicators, mechanical pop-up indicators, and electrical with mechanical pop-up indicators. As contaminating particles collect on the filter element, the differential pressure across the element increases. In some installations using

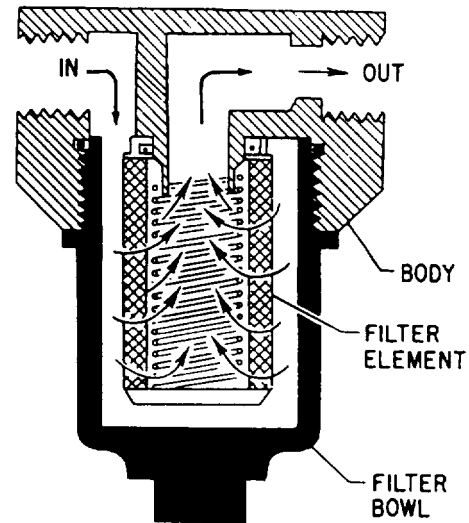

Figure 9-10.—Full-flow hydraulic filter.

gauges as indicators, the differential pressure must be obtained by subtracting the readings of two gauges located somewhere along the filter inlet and outlet piping. For pop-up indicators, when the increase in pressure reaches a specific value, an indicator (usually in the filter head) pops out, signifying that the filter must be cleaned or replaced. A low-temperature lockout feature is installed in most pop-up types of contamination indicators to eliminate the possibility of false indications due to cold weather because the pressure differential may be much higher with a cold fluid due to increased viscosity.

Filter elements used in filters that have a contamination indicator are not normally removed or replaced until the indicator is actuated. This decreases the possibility of system contamination from outside sources due to unnecessary handling.

The use of the nonbypassing type of filter eliminates the possibility of contaminated fluid bypassing the filter element and contaminating the entire system. This type of filter will minimize the necessity for flushing the entire system and lessen the possibility of failure of pumps and other components in the system.

A bypass relief valve is installed in some filters. The bypass relief valve allows the fluid to bypass the filter element and pass directly through the outlet port in the event that the filter element becomes clogged. These filters may or may not be equipped with the contamination indicator. Figure 9-11 shows a full-flow bypass-type

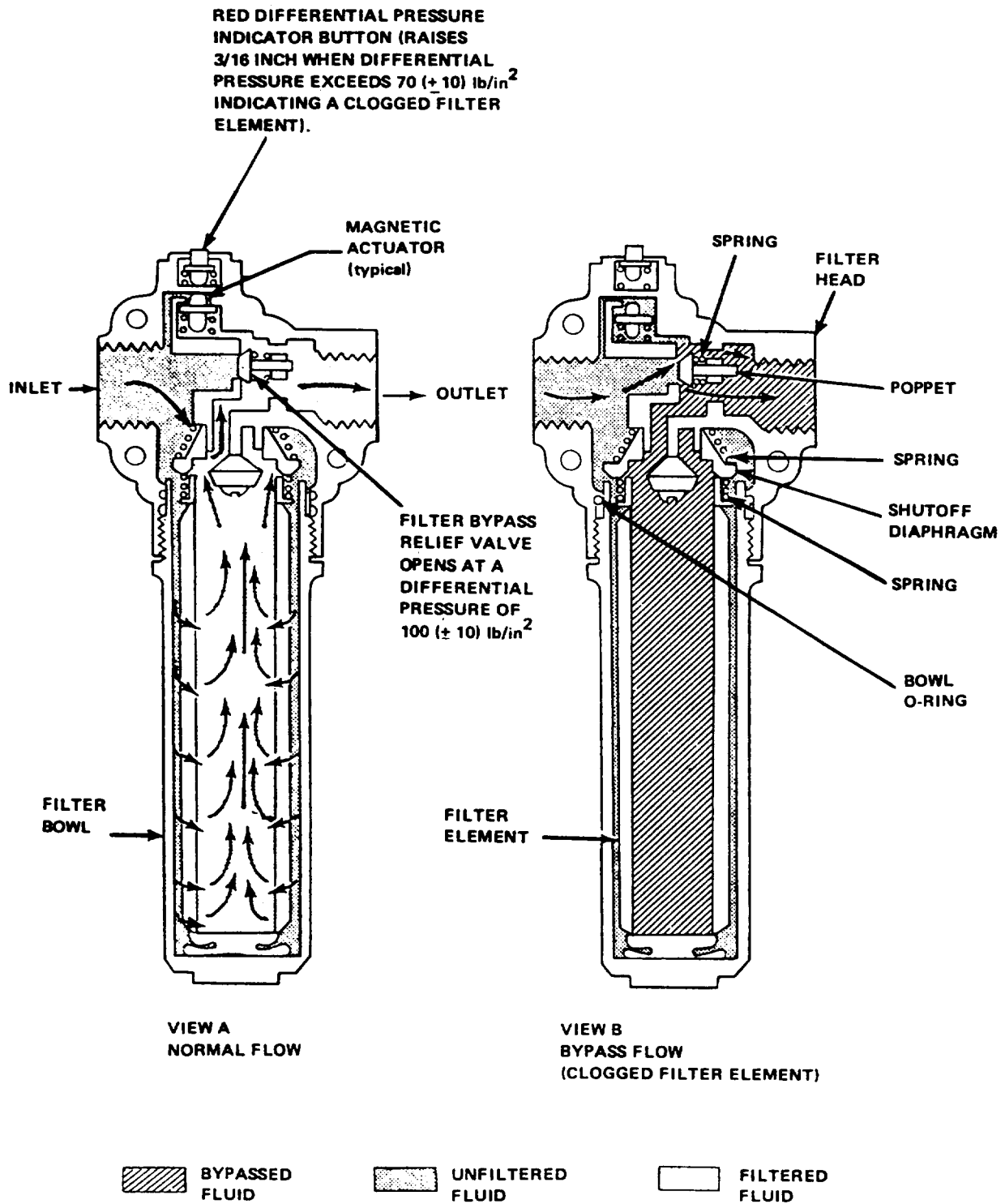

Figure 9-11.—Full-flow bypass-type hydraulic filter (with contamination indicator).

hydraulic filter with a contamination indicator. Figure 9-12 shows a full-flow bypass-type hydraulic filter without a contamination indicator.

A filter bypass indicator provides a positive indication, when activated, that fluid is bypassing the filter element by flowing through the bypass relief valve. This indicator should not be confused with the pop-up differential pressure indicator previously discussed which simply monitors the pressure across the element. With the bypass indicator, a similar pop-up button is often used to signal that maintenance is needed. However, the bypass indicators further signal that, as a result of the high differential pressures across the element, an internal bypass relief valve has lifted and some of the fluid is bypassing the element.

Identification of the type of installed indicator can be obtained from filter manifold drawings or related equipment manuals. Both a fluid bypass indicator and a differential pressure indicator or gauge may be installed on the same filter assembly.

As with differential pressure indicators, bypass relief indicators can be activated by pressure surges, such as may develop during cold starts or rapid system pressurization. On some relief indicators, the pop-up button, or whatever signal device is used, will return to a normal position when the surge passes and pressure is reduced. Other relief indicators may continue to indicate a bypass condition until they are manually reset.

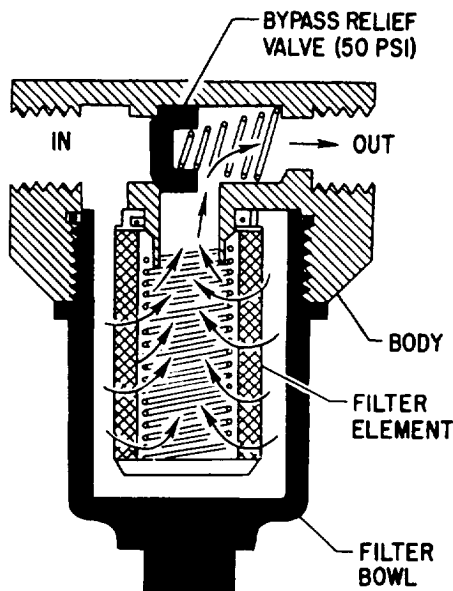

Figure 9-12.—Full-flow bypass-type hydraulic filter.

Before corrective action is taken based on indicator readings, the bypass condition should be verified at normal operating temperature and flow conditions by attempting to reset the indicator.

Proportional-Flow Filter

This type of filter operates on the venturi principle. (See glossary.) As the fluid passes through the venturi throat a drop in pressure is created at the narrowest point. See figure 9-13. A portion of the fluid flowing toward and away from the throat of the venturi flows through the passages into the body of the filter. A fluid passage connects the hollow core of the filter with the throat of the venturi. Thus, the low-pressure area at the throat of the venturi causes the fluid under pressure in the body of the filter to flow through the filter element, through the hollow core, into the low-pressure area, and then return to the system. Although only a portion of the fluid is filtered during each cycle, constant recirculation through the system will eventually cause all the fluid to pass through the filter element.

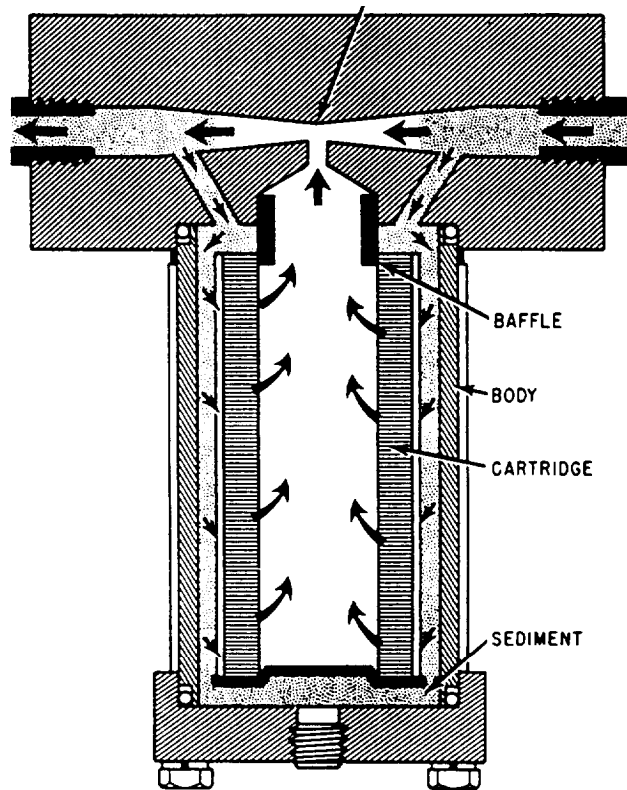

Figure 9-13. Proportional-flow filter.

Filter Rating

Filters are rated in several ways—absolute, mean, and nominal. The absolute filtration rating is the diameter in microns of the largest spherical particle that will pass through the filter under a certain test condition. This rating is an indication of the largest opening in the filter element. The mean filtration rating is the measurement of the average size of the openings in the filter element. The nominal filtration rating is usually interpreted to mean the size of the smallest particles of which 90 percent will be trapped in the filter at each pass through the filter.

Filter Elements

Filter elements generally may be divided into two classes—surface and depth. Surface filters are made of closely woven fabric or treated paper with a uniform pore size. Fluid flows through the pores of the filter material and contaminants are stopped on the filter's surface. This type of element is designed to prevent the passage of a high percentage of solids of a specific size. Depth filters, on the other hand, are composed of layers of fabric or fibers which provide many tortuous paths for the fluid to flow through. The pores or passages must be larger than the rated size of the filter if particles are to be retained in the depth of the media rather than on the surface. Consequently, there is a statistical probability that a rather large particle may pass through a depth-type filter.

Filter elements may be of the 5-micron, woven mesh, micronic, porous metal, or magnetic type. The micronic and 5-micron elements have noncleanable filter media and are disposed of when they are removed. Porous metal, woven mesh, and magnetic filter elements are usually designed to be cleaned and reused.

5-MICRON NONCLEANABLE FILTER ELEMENTS.— The most common 5-micron filter medium is composed of organic and inorganic fibers integrally bonded by epoxy resin and faced with a metallic mesh upstream and downstream for protection and added mechanical strength. Filters of this type are not to be cleaned under any circumstances and will be marked Disposable or Noncleanable.

Another 5-micron filter medium uses layers of very fine stainless-steel fibers drawn into a random but controlled matrix. Filter elements

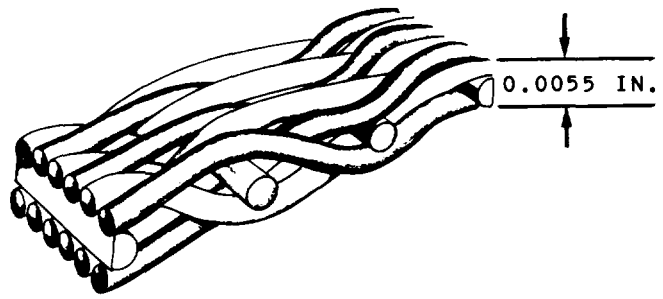

Figure 9-14.—Cross-section of a stainless steel hydraulic filter element.

of this material may be either cleanable or noncleanable, depending upon their construction.

WOVEN WIRE-MESH FILTER ELEMENTS.— Filters of this type are made of stainless steel and are generally rated as 15 or 25 micron (absolute). Figure 9-14 shows a magnified cross section of a woven wire-mesh filter element. This type of filter is reusable.

MICRONIC HYDRAULIC FILTER ELEMENT.— The term *micronic* is derived from the word *micron*. It could be used to describe any filter element; however, through usage, this term has become associated with a specific filter with a filtering element made of a specially treated cellulose paper (fig. 9-15). The filter shown in figure 9-10 is a typical micronic hydraulic filter. This filter is designed to remove 99 percent of all particles 10 to 20 microns in diameter or larger.

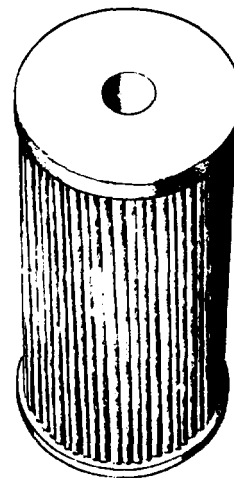

Figure 9-15.—Micronic filter element.

The replaceable element is made of specially treated convolutions (wrinkles) to increase its dirt-holding capacity. The element is noncleanable and should be replaced with a new filter element during maintenance inspections.

MAGNETIC FILTERS.— Some hydraulic systems have magnetic filters installed at strategic points. Filters of this type are designed primarily to trap any ferrous particles that may be in the system.

PNEUMATIC GASES

Clean, dry gas is required for the efficient operation of pneumatic systems. Due to the normal conditions of the atmosphere, free air seldom satisfies these requirements adequately. The atmosphere contains both dust and impurities in various amounts and a substantial amount of moisture in vapor form.

Solids, such as dust, rust, or pipe scale in pneumatic systems, may lead to excessive wear and failure of components and, in some cases, may prevent the pneumatic devices from operating. Moisture is also very harmful to the system. It washes lubrication from moving parts, thereby aiding corrosion and causing excessive wear of components. Moisture will also settle in low spots in the system and freeze during cold weather, causing a stoppage of the system or ruptured lines.

An ideal filter would remove all dirt and moisture from a pneumatic system without causing a pressure drop in the process. Obviously, such a condition can only be approached; it cannot be attained.

Removal of Solids

The removal of solids from the gas of pneumatic systems is generally done by screening (filtering), centrifugal force, or a combination of the two. In some cases, the removal of moisture is done in conjunction with the removal of solids.

Some types of air filters are similar in design and operation to the hydraulic filters discussed earlier. Some materials used in the construction of elements for air filters are woven screen wire, steel wool, fiber glass, and felt fabrics. Elements made of these materials are often used in the unit that filters the air as it enters the compressor.

Porous metal and ceramic elements are commonly used in filters that are installed in the compressed air supply lines. These filters also use a controlled air path to provide some filtration. Internal design causes the air to flow in a circular path within the bowl (fig. 9-16). Heavy particles and water droplets are thrown out of the airstream

and drop to the bottom of the bowl. The air then flows through the filter element, which filters out most of the smaller particles. This type of filter is designed with a drain valve at the bottom of the bowl. When the valve is opened with air pressure in the system, the accumulation of solids and water will be blown out of the bowl.

An air filter that uses moving mechanical devices as an element is illustrated in figure 9-17. As compressed air passes through the filter the force revolves a number of multi-blade rotors at high speed. Moisture and dirt are caught on the blades of the rotors. The whirling blades hurl the impurities by centrifugal force to the outer rims of the rotors and to the inner walls of the filter housing. Here, contaminating matter is out of the airstream and falls to the bottom of the bowl where it must be drained at periodic intervals.

Removal of Moisture

The removal of moisture from compressed air is important for a compressed air system. If air at atmospheric pressure, even at a very low relative humidity, is compressed to 3000 or 4500 psi, it becomes saturated with water vapor. Some moisture is removed by the intercoolers and aftercoolers (see glossary). Also, air flasks, receivers, and banks are provided with low point drains to allow periodic draining of any collected moisture. However, many uses of air require air with an even smaller moisture content than can be obtained through these methods. Moisture in

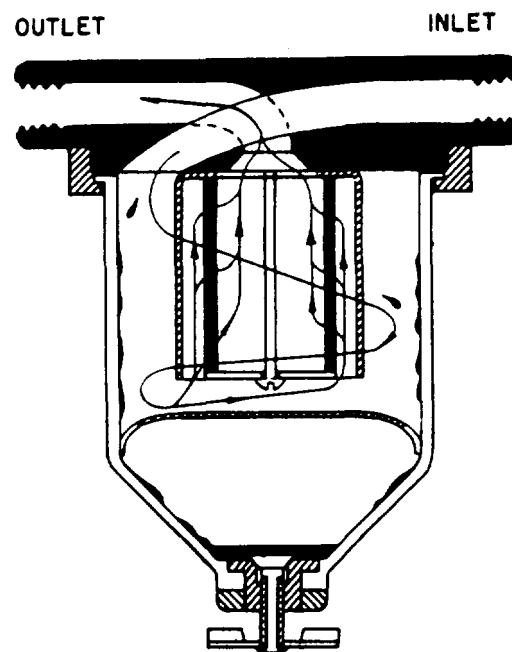

Figure 9-16.—Air filter.

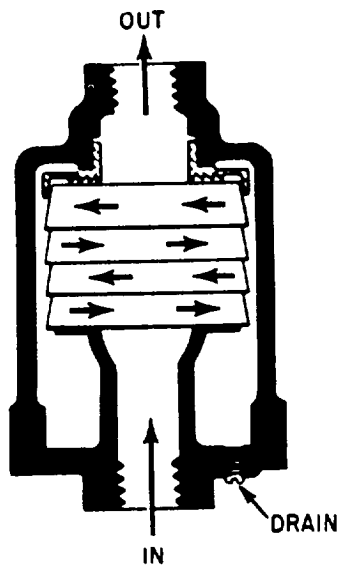

Figure 9-17.—Air filter using rotating blades as element.

air lines can create problems which are potentially hazardous, such as the freezing of valves and controls. This can occur, for example, if very high pressure air is throttled to a very low pressure at a high flow rate. The venturi effect of the throttled air produces very low temperatures which will cause any moisture in the air to freeze into ice. This makes the valve (especially an automatic valve) either very difficult or impossible to operate. Also, droplets of water can cause serious water hammer in an air system which has high pressure and a high flow rate and can cause corrosion, rust, and dilution of lubricants within the system. For these reasons, air driers

(*dehydrator, air purifier, and desiccator* are all terms used by different manufacturers to identify these components) are used to dry the compressed air. Some water removal devices are similar in design and operation to the filters shown in figures 9-16 and 9-17. Two basic types of air dehydrators are the refrigerated-type and the desiccant-type.

REFRIGERATED-TYPE DEHYDRATORS.—

In refrigerated-type dehydrators, compressed air is passed over a set of refrigerated cooling coils. Oil and moisture vapors condense from the air and can be collected and removed via a low point drain.

DESICCANT-TYPE DEHYDRATORS.—

A desiccant is a chemical substance with a high capacity to absorb water or moisture. It also has the capacity to give off that moisture so that the desiccant can be reused.

Some compressed air system dehydrators use a pair of desiccant towers (flasks full of desiccant). One is kept in service dehydrating the compressed air, while the other one is being reactivated. A desiccant tower is normally reactivated by passing dry, heated air through it in the direction opposite the normal dehydration airflow.

Another type of chemical drier is shown in figure 9-18. This unit consists of the housing, a cartridge containing a chemical agent, a filter (sintered bronze), and a spring. Various types of absorbent chemicals are used by the different manufacturers in the construction of the cartridges. To ensure proper filtering, the air must pass through the drier in the proper direction. The correct direction of flow is indicated by an arrow and the word *FLOW* printed on the side of the cartridge.

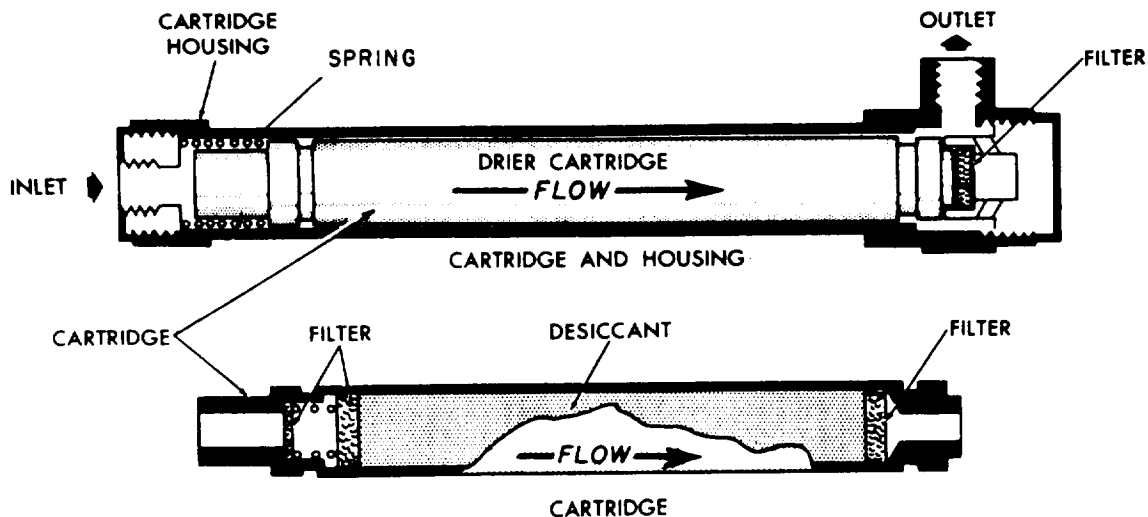

Figure 9-18.—Chemical drier.

CHAPTER 10

ACTUATORS

One of the outstanding features of fluid power systems is that force, generated by the power supply, controlled and directed by suitable valving, and transported by lines, can be converted with ease to almost any kind of mechanical motion desired at the very place it is needed. Either linear (straight line) or rotary motion can be obtained by using a suitable actuating device.

An actuator is a device that converts fluid power into mechanical force and motion. Cylinders, motors, and turbines are the most common types of actuating devices used in fluid power systems.

This chapter describes various types of actuating cylinders and their applications, different types of fluid motors, and turbines used in fluid power systems.

CYLINDERS

An actuating cylinder is a device that converts fluid power to linear, or straight line, force and motion. Since linear motion is a back-and-forth motion along a straight line, this type of actuator is sometimes referred to as a reciprocating, or linear, motor. The cylinder consists of a ram or piston operating within a cylindrical bore. Actuating cylinders may be installed so that the cylinder is anchored to a stationary structure and the ram or piston is attached to the mechanism to be operated, or the piston or ram may be anchored to the stationary structure and the cylinder attached to the mechanism to be operated.

Actuating cylinders for pneumatic and hydraulic systems are similar in design and operation. Some of the variations of ram- and piston-type actuating cylinders are described in the following paragraphs.

RAM-TYPE CYLINDERS

The terms *ram* and *piston* are often used interchangeably. However, a ram-type cylinder is

usually considered one in which the cross-sectional area of the piston rod is more than one-half the cross-sectional area of the movable element. In most actuating cylinders of this type, the rod and the movable element have equal areas. This type of movable element is frequently referred to as a plunger.

The ram-type actuator is used primarily to push rather than to pull. Some applications require simply a flat surface on the external part of the ram for pushing or lifting the unit to be operated. Other applications require some mechanical means of attachment, such as a clevis or eyebolt. The design of ram-type cylinders varies in many other respects to satisfy the requirements of different applications.

Single-Acting Ram

The single-acting ram (fig. 10-1) applies force in only one direction. The fluid that is directed into the cylinder displaces the ram and forces it outward, lifting the object placed on it. Since there

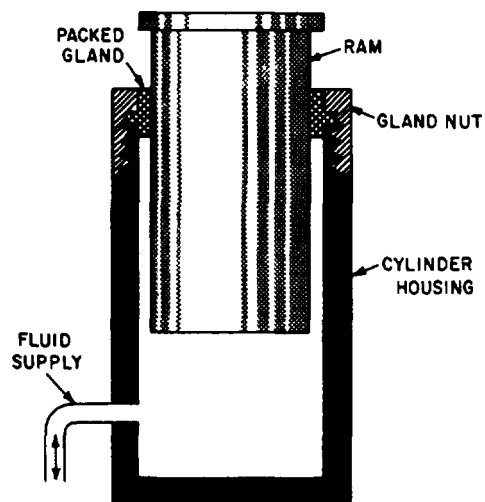

Figure 10-1.—Single-acting ram-type actuating cylinder.

is no provision for retracting the ram by fluid power, when fluid pressure is released, either the weight of the object or some mechanical means, such as a spring, forces the ram back into the cylinder. This forces the fluid back to the reservoir.

The single-acting ram-type actuating cylinder is often used in the hydraulic jack. The elevators used to move aircraft to and from the flight deck and hangar deck on aircraft carriers also use cylinders of this type. In these elevators, the cylinders are installed horizontally and operate the elevator through a series of cables and sheaves. Fluid pressure forces the ram outward and lifts the elevator. When fluid pressure is released from the ram, the weight of the elevator forces the ram back into the cylinder. This, in turn, forces the fluid back into the reservoir.

Double-Acting Ram

A double-acting ram-type cylinder is illustrated in figure 10-2. In this cylinder, both strokes of the ram are produced by pressurized fluid. There are two fluid ports, one at or near each end of the cylinder. Fluid under pressure is directed to the closed end of the cylinder to extend the ram and apply force. To retract the ram and reduce the force, fluid is directed to the opposite end of the cylinder.

A four-way directional control valve is normally used to control the double-acting ram. When the valve is positioned to extend the ram, pressurized fluid enters port A (fig. 10-2), acts on

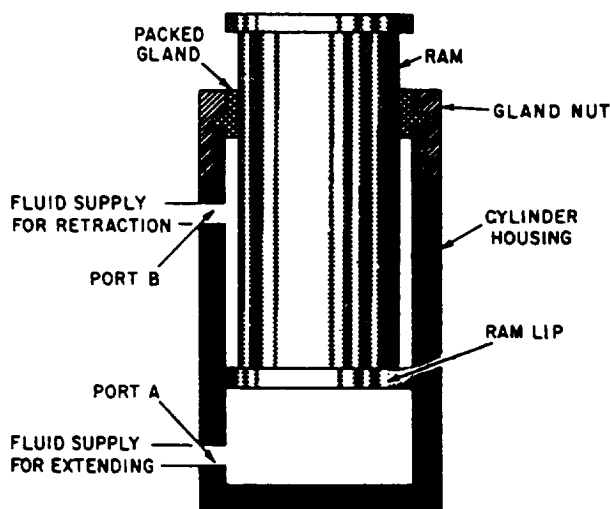

Figure 10-2.—Double-acting ram-type actuating cylinder.

the bottom surface of the ram, and forces the ram outward. Fluid above the ram lip is free to flow out of port B, through the control valve, and to the return line in hydraulic systems or to the atmosphere in pneumatic systems.

Normally, the pressure of the fluid is the same for either stroke of the ram. Recall from chapter 2 that force is equal to pressure times area ($F = PA$). Notice the difference of the areas upon which the pressure acts in figure 10-2. The pressure acts against the large surface area on the bottom of the ram during the extension stroke, during which time the ram applies force. Since the ram does not require a large force during the retraction stroke, pressure acting on the small area on the top surface of the ram lip provides the necessary force to retract the ram.

Telescoping Rams

Figure 10-3 shows a telescoping ram-type actuating cylinder. A series of rams is nested in the telescoping assembly. With the exception of the smallest ram, each ram is hollow and serves as the cylinder housing for the next smaller ram. The ram assembly is contained in the main cylinder assembly, which also provides the fluid ports. Although the assembly requires a small space with all the rams retracted, the telescoping action of the assembly provides a relatively long stroke when the rams are extended.

An excellent example of the application of this type of cylinder is in the dump truck. It is used to lift the forward end of the truck bed and dump the load. During the lifting operation, the greatest force is required for the initial lifting of the load.

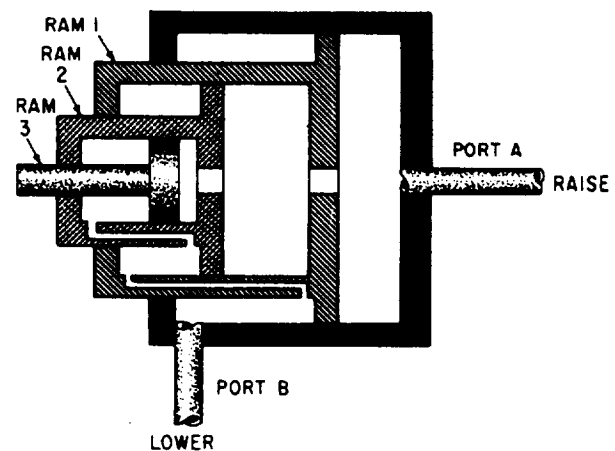

Figure 10-3.—Telescoping ram-type actuating cylinder.

As the load is lifted and begins to dump, the required force becomes less and less until the load is completely dumped. During the raise cycle, pressurized fluid enters the cylinder through port A (fig. 10-3) and acts on the bottom surface of all three rams. Ram 1 has a larger surface area and, therefore, provides the greater force for the initial load. As ram 1 reaches the end of its stroke and the required force is decreased, ram 2 moves, providing the smaller force needed to continue raising the load. When ram 2 completes its stroke, a still smaller force is required. Ram 3 then moves outward to finish raising and dumping the load.

Some telescoping ram-type cylinders are of the single-acting type. Like the single-acting ram discussed previously, these telescoping ram-type cylinders are retracted by gravity or mechanical force. Some hydraulic jacks are equipped with telescoping rams. Such jacks are used to lift vehicles with low clearances to the required height.

Other types of telescoping cylinders, like the one illustrated in figure 10-3, are of the double-acting type. In this type, fluid pressure is used for both the extension and retraction strokes. A four-way directional control valve is commonly used to control the operation of the double-acting type. Note the small passages in the walls of rams 1 and 2. They provide a path for fluid to flow to and from the chambers above the lips of rams 2 and 3. During the extension stroke, return fluid flows through these passages and out of the cylinder through port B. It then flows through the directional control valve to the return line or reservoir.

To retract the rams, fluid under pressure is directed into the cylinder through port B and acts against the top surface areas of all three ram lips. This forces the rams to the retracted position. The displaced fluid from the opposite side of the rams flows out of the cylinder through port A, through the directional control valve to the return line or reservoir.

Dual Rams

A dual ram assembly consists of a single ram with a cylinder at either end (fig. 10-4). Fluid can be directed to either cylinder, forcing the ram to move in the opposite direction. The ram is connected through mechanical linkage to the unit to be operated. A four-way directional control valve is commonly used to operate the dual ram. When the control valve is positioned to direct fluid under pressure to one of the cylinders (let's say the left one), the ram is forced to the right. This

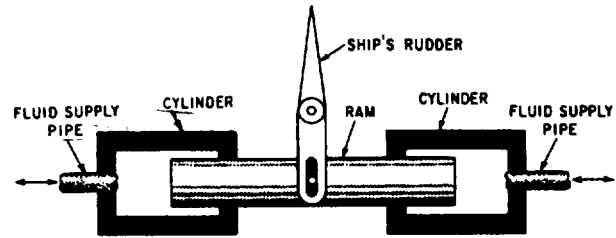

Figure 10-4.-Dual ram actuating assembly.

action displaces the fluid in the opposite cylinder. The displaced fluid flows back through the directional control valve to the return line or reservoir in hydraulic systems or to the atmosphere in pneumatic systems.

Dual ram actuating assemblies are used in steering systems of most ships. In some systems, one assembly is used to actuate the rudder in either direction; while in other systems, two assemblies are used for the same purpose.

PISTON-TYPE CYLINDERS

An actuating cylinder in which the cross-sectional area of the piston is less than one-half the cross-sectional area of the movable element is referred to as a piston-type cylinder. This type of cylinder is normally used for applications that require both push and pull functions. The piston-type cylinder is the most common type used in fluid power systems.

The essential parts of a piston-type cylinder are a cylindrical barrel, a piston and rod, end caps, and suitable seals. The end caps are attached to the ends of the barrel. These end caps usually contain the fluid ports. The end cap on the rod end contains a hole for the piston rod to pass through. Suitable seals are used between the hole and the piston rod to keep fluid from leaking out and to keep dirt and other contaminants from entering the barrel. The opposite end cap of most cylinders is provided with a fitting for securing the actuating cylinder to some structure. This end cap is referred to as the anchor end cap.

The piston rod may extend through either or both ends of the cylinder. The extended end of the rod is normally threaded so that some type of mechanical connector, such as an eyebolt or a clevis, and a locknut can be attached. This threaded connection of the rod and mechanical connector provides for adjustment between the rod and the unit to be actuated. After the correct

adjustment is made, the locknut is tightened against the connector to prevent the connector from turning. The other end of the connector is attached, either directly or through additional mechanical linkage, to the unit to be actuated.

In order to satisfy the many requirements of fluid power systems, piston-type cylinders are available in various designs.

Single-Acting Cylinder

The single-acting piston-type cylinder is similar in design and operation to the single-acting ram-type cylinder. The single-acting piston-type cylinder uses fluid pressure to provide the force in one direction, and spring tension, gravity, compressed air, or nitrogen is used to provide the force in the opposite direction. Figure 10-5 shows a single-acting, spring-loaded, piston-type actuating cylinder. In this cylinder the spring is located on the rod side of the piston. In some spring-loaded cylinders the spring is located on the blank side, and the fluid port is on the rod side of the cylinder.

A three-way directional control valve is normally used to control the operation of the single-acting piston-type cylinder. To extend the piston rod, fluid under pressure is directed through the port into the cylinder (fig. 10-5). This pressure acts on the surface area of the blank side of the piston and forces the piston to the right. This action moves the rod to the right, through the end of the cylinder, thus moving the actuated unit in one direction. During this action, the spring is compressed between the rod side of the piston and the end of the cylinder. The length of the stroke depends upon the physical limits within the cylinder and the required movement of the actuated unit.

To retract the piston rod, the directional control valve is moved to the opposite working position, which releases the pressure in the

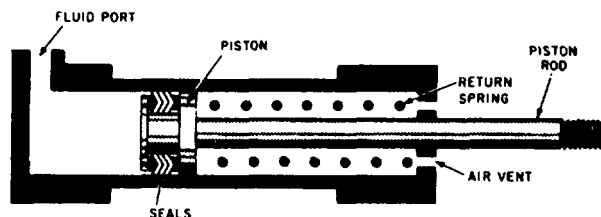

Figure 10-5.—Single-acting, spring-loaded, piston-type actuating cylinder.

cylinder. The spring tension forces the piston to the left, retracting the piston rod and moving the actuated unit in the opposite direction. The fluid is free to flow from the cylinder through the port, back through the control valve to the return line in hydraulic systems or to the atmosphere in pneumatic systems.

The end of the cylinder opposite the fluid port is vented to the atmosphere. This prevents air from being trapped in this area. Any trapped air would compress during the extension stroke, creating excess pressure on the rod side of the piston. This would cause sluggish movement of the piston and could eventually cause a complete lock, preventing the fluid pressure from moving the piston.

The spring-loaded cylinder is used in arresting gear systems on some models of carrier aircraft. To raise (retract) the arresting hook, fluid pressure is directed through the arresting hook control valve to the rod side of the cylinder. This force moves the piston, which, through the rod and mechanical linkage, retracts the arresting hook. The arresting hook extends when fluid pressure is released from the rod side of the cylinder, allowing the spring to expand.

Leakage between the cylinder wall and piston is prevented by adequate seals. The piston in figure 10-5 contains V-ring seals.

Double-Acting Cylinder

Most piston-type actuating cylinders are double-acting, which means that fluid under pressure can be applied to either side of the piston to apply force and provide movement.

One design of the double-acting cylinder is shown in figure 10-6. This cylinder contains one piston and piston rod assembly. The stroke of the piston and piston rod assembly in either direction is produced by fluid pressure. The two fluid ports, one near each end of the cylinder, alternate as inlet and outlet ports, depending on the direction of

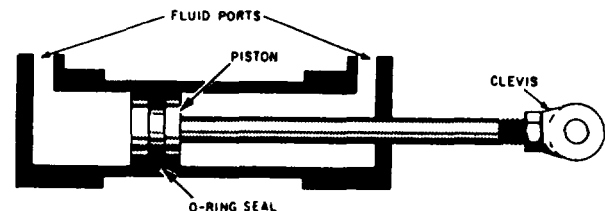

Figure 10-6.—Double-acting piston-type actuating cylinder.

flow from the directional control valve. This actuator (fig. 10-6) is referred to as an unbalanced actuating cylinder because there is a difference in the effective working areas on the two sides of the piston. Therefore, this type of cylinder is normally installed so that the blank side of the piston carries the greater load; that is, the cylinder carries the greater load during the piston rod extension stroke.

A four-way directional control valve is normally used to control the operation of this type of cylinder. The valve can be positioned to direct fluid under pressure to either end of the cylinder and allow the displaced fluid to flow from the opposite end of the cylinder through the control valve to the return line in hydraulic systems or to the atmosphere in pneumatic systems.

There are applications where it is necessary to move two mechanisms at the same time. In this case, double-acting piston-type actuating cylinders of different designs are required. See figures 10-7 and 10-8.

Figure 10-7 shows a three-port, double-acting piston-type actuating cylinder. This actuator contains two pistons and piston rod assemblies. Fluid is directed through port A by a four-way directional control valve and moves the pistons outward, thus moving the mechanisms attached to the pistons' rods. The fluid on the rod side of each piston is forced out of the cylinder through ports B and C, which are connected by a common line to the directional control valve. The displaced fluid then flows through the control valve to the return line or to the atmosphere.

When fluid under pressure is directed into the cylinder through ports B and C, the two pistons move inward, also moving the mechanisms attached to them. Fluid between the two pistons is free to flow from the cylinder through port A and through the control valve to the return line or to the atmosphere.

The actuating cylinder shown in figure 10-8 is a double-acting balanced type. The piston rod extends through the piston and out through both ends of the cylinder. One or both ends of the



Figure 10-7.—Three-port, double-acting actuating cylinder.

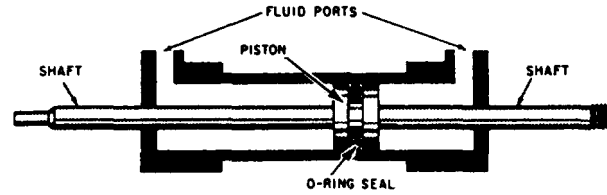

Figure 10-8.—Balanced, double-acting piston-type actuating cylinder.

piston rod may be attached to a mechanism to be operated. In either case, the cylinder provides equal areas on each side of the piston. Therefore, the same amount of fluid and force is used to move the piston a certain distance in either direction.

Tandem Cylinders

A tandem actuating cylinder consists of two or more cylinders arranged one behind the other but designed as a single unit (fig. 10-9). This type of actuating cylinder is used in applications that require two or more independent systems; for example, power-operated flight control systems in naval aircraft.

The flow of fluid to and from the two chambers of the tandem actuating cylinder is provided from two independent hydraulic systems and is controlled by two sliding spool directional control valves. In some applications, the control valves and the actuating cylinder are two separate units. In some units, the pistons (lands) of the two sliding spools are machined on one common shaft. In other applications, the valves and the actuator are directly connected in one compact unit. Although the two control valves are hydraulically independent, they are interconnected mechanically. In other units, the two sliding spools are connected through mechanical linkages with a synchronizing rod. In either case, the movement of the two sliding spools is synchronized, thus equalizing the

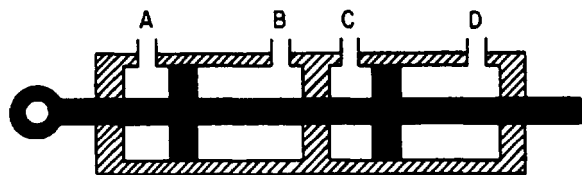

Figure 10-9.—Tandem actuating cylinder.

flow of fluid to and from the two chambers of the actuating cylinder.

Since the two control valves operate independently of each other as far as hydraulic pressure is concerned, failure of either hydraulic system does not render the actuator inoperative. Failure of one system does reduce the output force by one-half; however, this force is sufficient to permit operation of the actuator.

RACK-AND-PINION PISTON-TYPE ROTARY ACTUATORS

The rack-and-pinion-type actuators, also referred to as limited rotation cylinders, of the single or multiple, bidirectional piston are used for turning, positioning, steering, opening and closing, swinging, or any other mechanical function involving restricted rotation. Figure 10-10 shows a typical rack-and-pinion double-piston actuator.

The actuator consists of a body and two reciprocating pistons with an integral rack for rotating the shaft mounted in roller or journal bearings. The shaft and bearings are located in a central position and are enclosed with a bearing cap. The pistons, one on each side of the rack, are enclosed in cylinders machined or sleeved into the body. The body is enclosed with end caps and static seals to prevent external leakage of pressurized fluid.

Only a few of the many applications of actuating cylinders were discussed in the preceding paragraphs. Figure 10-11 shows additional types of force and motion applications.

In addition to its versatility, the cylinder-type actuator is probably the most trouble-free component of fluid power systems. However, it is very important that the cylinder, mechanical linkage, and actuating unit are correctly aligned. Any misalignment will cause excessive wear of the piston, piston rod, and seals. Also, proper adjustment between the piston rod and the actuating unit must be maintained.

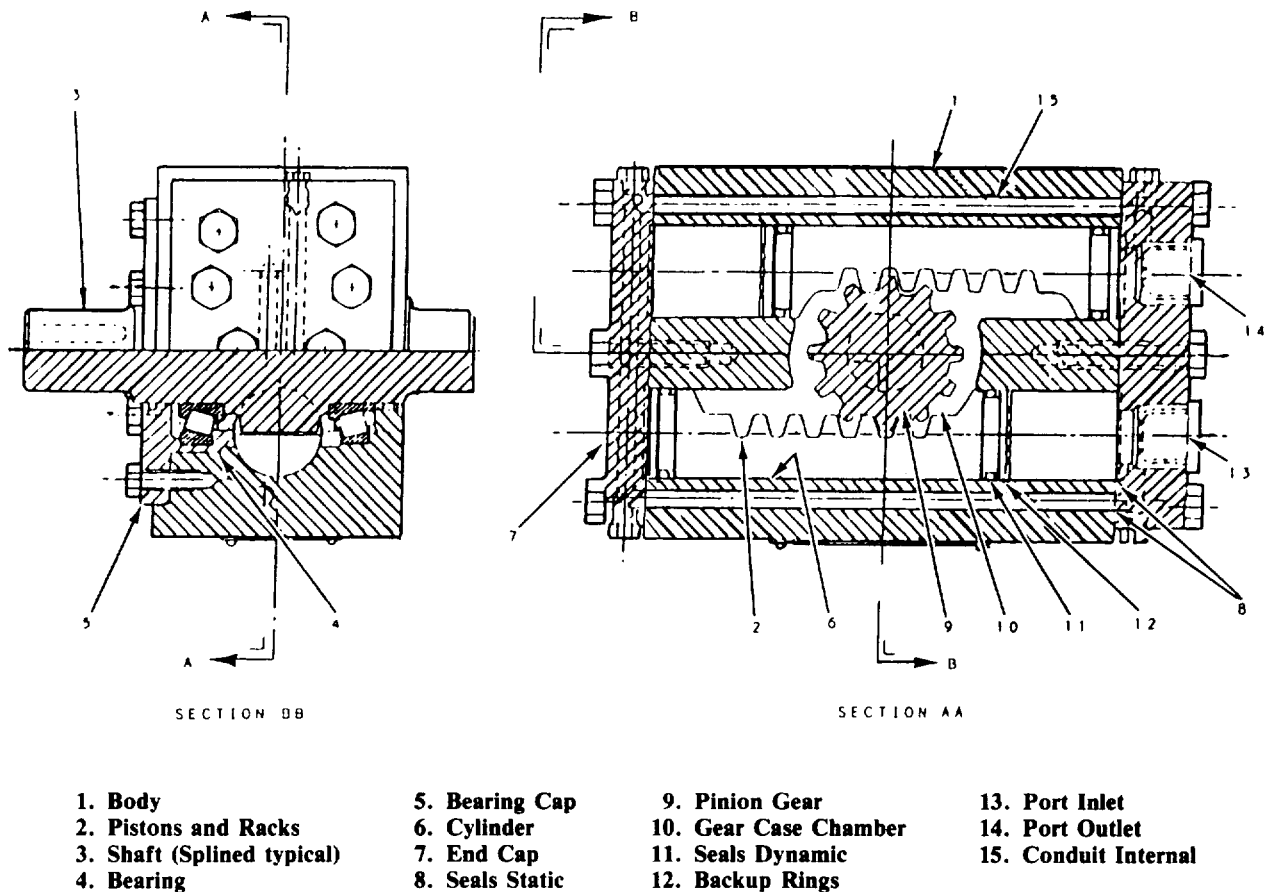

Figure 10-10.—Rack-and-pinion double-piston rotary actuator.

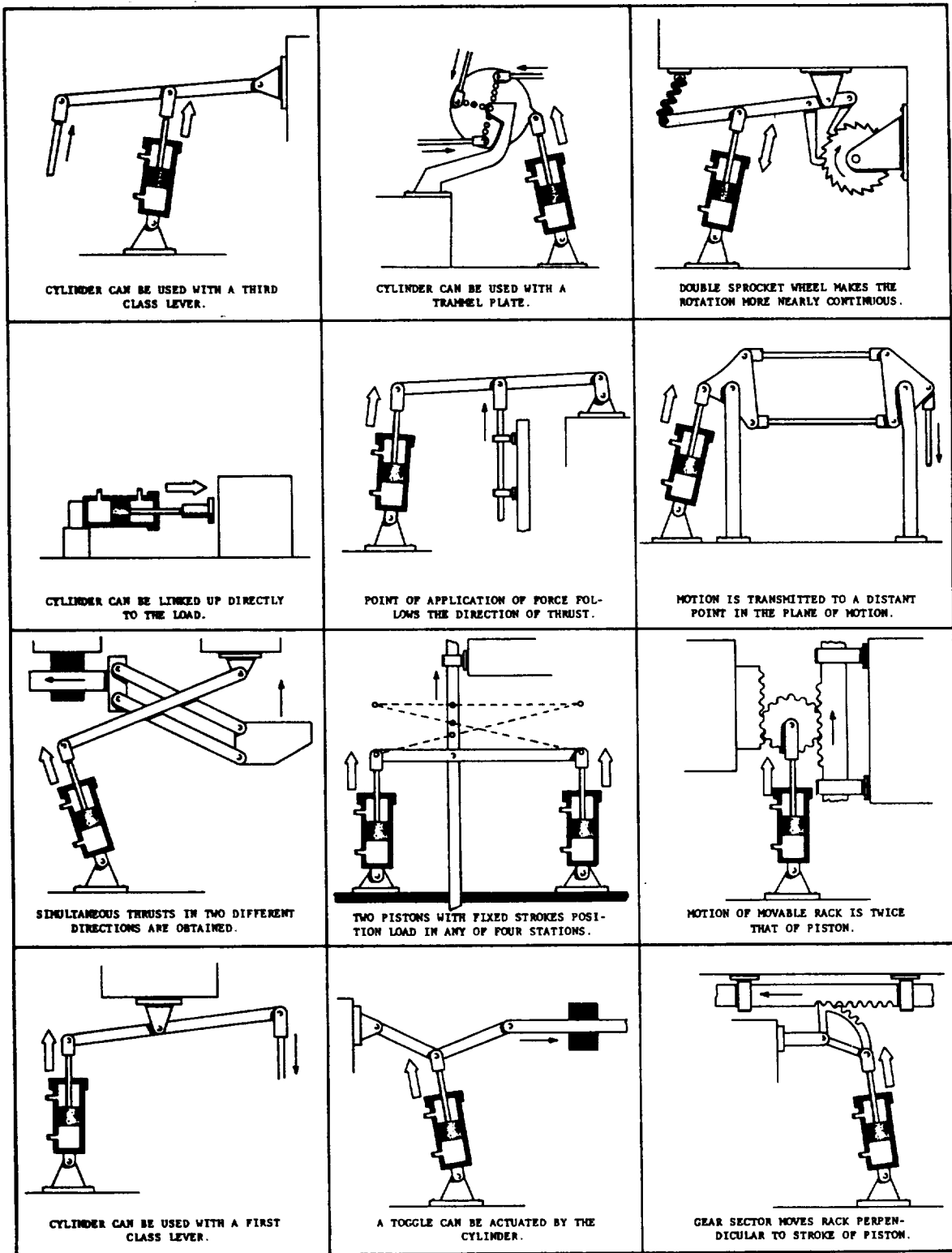

Figure 10-11.—Applications of actuating cylinders.

MOTORS

A fluid power motor is a device that converts fluid power energy to rotary motion and force. The function of a motor is opposite that of a pump. However, the design and operation of fluid power motors are very similar to pumps. Therefore, a thorough knowledge of the pumps described in chapter 4 will help you understand the operation of fluid power motors.

Motors have many uses in fluid power systems. In hydraulic power drives, pumps and motors are combined with suitable lines and valves to form hydraulic transmissions. The pump, commonly referred to as the A-end, is driven by some outside source, such as an electric motor. The pump delivers fluid to the motor. The motor, referred to as the B-end, is actuated by this flow, and through mechanical linkage conveys rotary motion and force to the work. This type of power drive is used to operate (train and elevate) many of the Navy's guns and rocket launchers. Hydraulic motors are commonly used to operate the wing flaps, radomes, and radar equipment in aircraft. Air motors are used to drive pneumatic tools. Air motors are also used in missiles to convert the kinetic energy of compressed gas into electrical power, or to drive the pump of a hydraulic system.

Fluid motors may be either fixed or variable displacement. Fixed-displacement motors provide constant torque and variable speed. The speed is varied by controlling the amount of input flow. Variable-displacement motors are constructed so that the working relationship of the internal parts can be varied to change displacement. The majority of the motors used in fluid power systems are the fixed-displacement type.

Although most fluid power motors are capable of providing rotary motion in either direction, some applications require rotation in only one direction. In these applications, one port of the motor is connected to the system pressure line and the other port to the return line or exhausted to the atmosphere. The flow of fluid to the motor is controlled by a flow control valve, a two-way directional control valve, or by starting and stopping the power supply. The speed of the motor may be controlled by varying the rate of fluid flow to it.

In most fluid power systems, the motor is required to provide actuation power in either direction. In these applications the ports are referred to as working ports, alternating as inlet and outlet ports. The flow to the motor is usually

controlled by either a four-way directional control valve or a variable-displacement pump.

Fluid motors are usually classified according to the type of internal element, which is directly actuated by the flow. The most common types of elements are the gear, the vane, and the piston, AU three of these types are adaptable for hydraulic systems, while only the vane type is used in pneumatic systems.

GEAR-TYPE MOTORS

The spur, helical, and herringbone design gears are used in gear-type motors. The motors use external-type gears, as discussed in chapter 4.

The operation of a gear-type motor is shown in figure 10-12. Both gears are driven gears; however, only one is connected to the output shaft. As fluid under pressure enters chamber A, it takes the path of least resistance and flows around the inside surface of the housing, forcing the gears to rotate as indicated. The flow continues through the outlet port to the return. This rotary motion of the gears is transmitted through the attached shaft to the work unit.

The motor shown in figure 10-12 is operating in one direction; however, the gear-type motor is capable of providing rotary motion in either direction. To reverse the direction of rotation, the ports may be alternated as inlet and outlet. When fluid is directed through the outlet port (fig. 10-12) into chamber B, the gears rotate in the opposite direction.

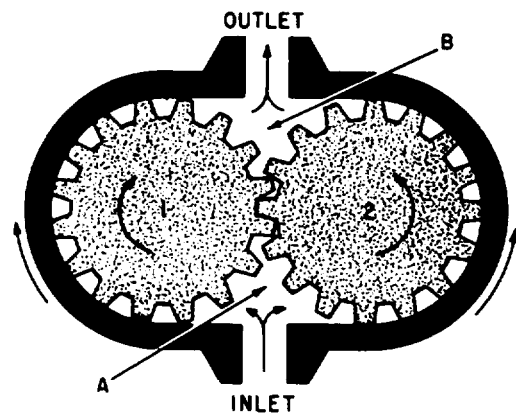

Figure 10-12.—Gear-type motor.

VANE-TYPE MOTORS

A typical vane-type air motor is shown in figure 10-13. This particular motor provides rotation in only one direction. The rotating element is a slotted rotor which is mounted on a drive shaft. Each slot of the rotor is fitted with a freely sliding rectangular vane. The rotor and vanes are enclosed in the housing, the inner surface of which is offset from the drive shaft axis. When the rotor is in motion, the vanes tend to slide outward due to centrifugal force. The distance the vanes slide is limited by the shape of the rotor housing.

This motor operates on the principle of differential areas. When compressed air is directed into the inlet port, its pressure is exerted equally in all directions. Since area A (fig. 10-13) is greater than area B, the rotor will turn counterclockwise. Each vane, in turn, assumes the No. 1 and No. 2 positions and the rotor turns continuously. The potential energy of the compressed air is thus converted into kinetic energy in the form of rotary motion and force. The air at reduced pressure is exhausted to the atmosphere. The shaft of the motor is connected to the unit to be actuated.

Many vane-type motors are capable of providing rotation in either direction. A motor of this design is shown in figure 10-14. This motor operates on the same principle as the vane motor shown in figure 10-13. The two ports may be alternately used as inlet and outlet, thus providing rotation in either direction. Note the springs in the slots of the rotor. Their purpose is to hold the vanes against the housing during the initial

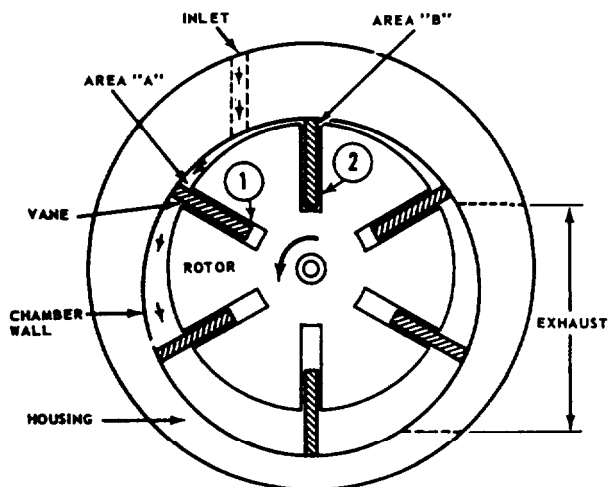

Figure 10-13.—Vane-type air motor.

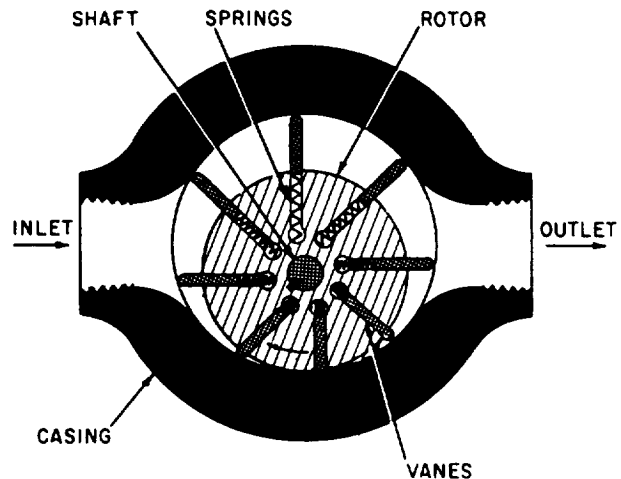

Figure 10-14.—Vane-type motor.

starting of the motor, since centrifugal force does not exist until the rotor begins to rotate.

PISTON-TYPE MOTORS

Piston-type motors are the most commonly used in hydraulic systems. They are basically the same as hydraulic pumps except they are used to convert hydraulic energy into mechanical (rotary) energy.

The most commonly used hydraulic motor is the fixed-displacement piston type. Some equipment uses a variable-displacement piston motor where very wide speed ranges are desired.

Although some piston-type motors are controlled by directional control valves, they are often used in combination with variable-displacement pumps. This pump-motor combination is used to provide a transfer of power between a driving element and a driven element. Some applications for which hydraulic transmissions may be used are speed reducers, variable speed drives, constant speed or constant torque drives, and torque converters. Some advantages of hydraulic transmission of power over mechanical transmission of power are as follows:

1. Quick, easy speed adjustment over a wide range while the power source is operating at a constant (most efficient) speed. Rapid, smooth acceleration or deceleration.
2. Control over maximum torque and power.
3. Cushioning effect to reduce shock loads.
4. Smoother reversal of motion.

Radial-Piston Motor

The radial-piston motor operates in reverse of the radial-piston pump. In the radial-piston pump, as the cylinder block rotates, the pistons press against the rotor and are forced in and out of the cylinders, thereby receiving fluid and pushing it out into the system. In the radial motor, fluid is forced into the cylinders and drives the pistons outward. The pistons pushing against the rotor cause the cylinder block to rotate.

The operation of a radial-piston motor is shown in figure 10-15. This motor is shown with three pistons for simplicity. Normally it contains seven or nine pistons. When liquid is forced into the cylinder bore containing piston 1, the piston moves outward since the liquid cannot be compressed. This causes the cylinder to rotate in a clockwise direction. As the force acting on piston 1 causes the cylinder block to rotate, piston 2 starts to rotate and approach the position of piston 3. (Note that the distance between the cylinder block and the reaction ring of the rotor gets progressively shorter on the top and right half of the rotor.)

As piston 2 rotates, it is forced inward and, in turn, forces the fluid out of the cylinder. Since there is little or no pressure on this side of the pintle valve, the piston is easily moved in by its contact with the reaction ring of the rotor. The fluid is easily forced out of the cylinder and back to the reservoir or to the inlet side of the pump. As the piston moves past the midpoint, or past the shortest distance between the cylinder block and the rotor, it enters the pressure side of the pintle valve and fluid is forced into the cylinder. Piston 3 then becomes the pushing piston and in turn rotates the cylinder block. This action

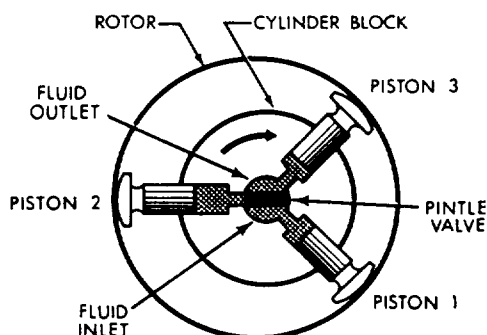

Figure 10-15.—Operation of a radial-piston motor.

continues as long as fluid under pressure enters the cylinders.

The direction of rotation of the motor (fig. 10-15) is changed by reversing the flow of fluid to it. Admitting fluid under pressure on the top side of the pintle valve forces piston 3 out of the cylinder block. This causes the cylinder to rotate in the counterclockwise direction.

Axial-Piston Motor

The variable-stroke axial-piston pump is often used as a part of variable speed gear, such as electrohydraulic anchor windlasses, cranes, winches, and the power transmitting unit in electrohydraulic steering engines. In those cases, the tilting box is arranged so that it may be tilted in either direction. Thus it may be used to transmit bidirectional power hydraulically to pistons or rams, or it may be used to drive a hydraulic motor. In the latter use, the pump is the A-end of the variable speed gear and the hydraulic motor is the B-end.

The B-end of the hydraulic unit of the hydraulic speed gear is exactly the same as the A-end of the variable-stroke pump mentioned previously. However, it generally does not have a variable-stroke feature. The tilting box is installed at a permanently fixed angle. Thus, the B-end becomes a fixed-stroke axial-piston motor. Figure 10-16 illustrates an axial-piston hydraulic speed gear with the A-end and B-end as a single unit. It is used in turrets for train and elevation driving units. For electrohydraulic winches and cranes, the A-end and B-end are in separate housings connected by hydraulic piping.

Hydraulic fluid introduced under pressure to a cylinder (B-end) tries to push the piston out of the cylinder. In being pushed out, the piston, through its piston rod, will seek the point of greatest distance between the top of the cylinder and the socket ring. The resultant pressure of the piston against the socket ring will cause the cylinder barrel and the socket ring to rotate. This action occurs during the half revolution while the piston is passing the intake port of the motor, which is connected to the pressure port of the pump. After the piston of the motor has taken all the hydraulic fluid it can from the pump, the piston passes the valve plate land and starts to discharge oil through the outlet ports of the motor

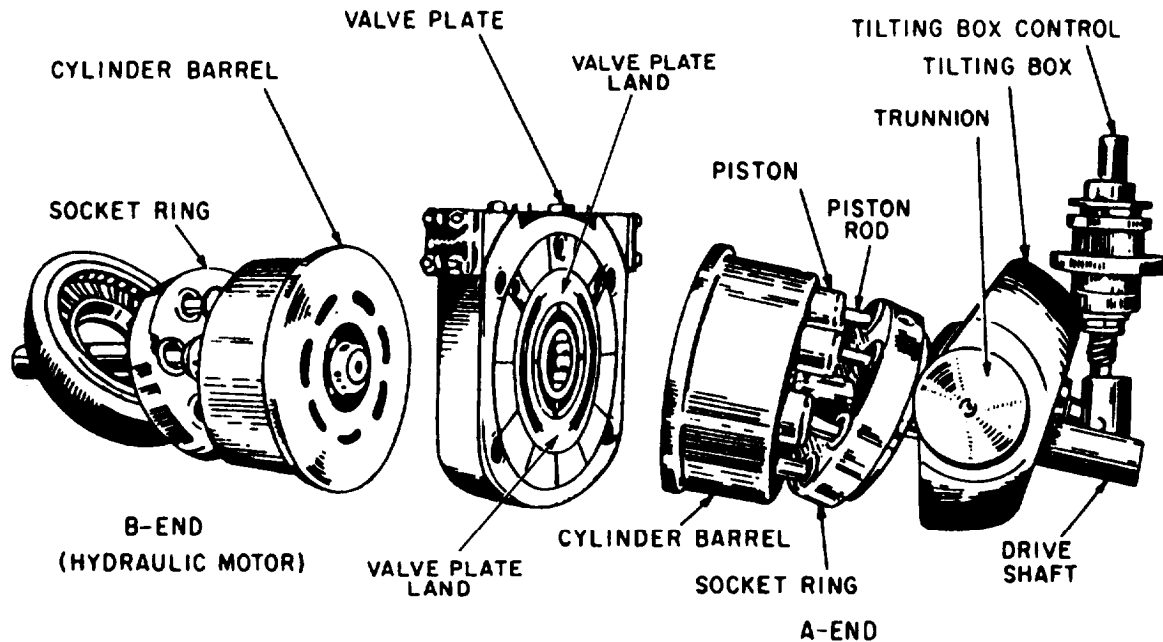

Figure 10-16.—Exploded view of a axial-piston hydraulic speed gear.

to the suction pistons of the pump. The pump is constantly putting pressure on one side of the motor and receiving hydraulic fluid from the other side. The fluid is merely circulated from pump to motor and back again.

Both of the axial-piston motors described in this section may be operated in either direction. The direction of rotation is controlled by the direction of fluid flow to the valve plate. The direction of flow may be instantly reversed without damage to the motor.

TURBINES

Turbines are used in pneumatic systems to convert kinetic energy of gases to mechanical energy. Turbines are used to drive electric generators, to convert mechanical energy into electrical energy, and to drive pumps to supply fluid flow in hydraulic systems.

The basic parts of a turbine are the rotor, which has blades projecting radially from its periphery; and nozzles, through which the gas is expanded and directed. The conversion of kinetic energy to mechanical energy occurs on the blades.

The basic distinction between types of turbines is the manner in which the gas causes the turbine rotor to move. When the rotor is moved by a direct push or "impulse" from the gas impinging upon the blades, the turbine is said to be an impulse turbine. When the rotor is moved by force of reaction, the turbine is said to be a reaction turbine.

Although the distinction between impulse turbines and reaction turbines is a useful one, it should not be considered as an absolute distinction in real turbines. An impulse turbine uses both the impulse of the gas jet and, to a lesser extent, the reactive force that results when the curved blades cause the gas to change direction. A reaction turbine is moved primarily by reactive force, but some motion of the rotor is caused by the impact of the gas against the blades.

IMPULSE TURBINE

The impulse turbine consists essentially of a rotor mounted on a shaft that is free to rotate in a set of bearings. The outer rim of the rotor carries a set of curved blades, and the whole assembly is enclosed in an airtight case. Nozzles direct the

rapidly moving fluid against the blades and turn the rotor (fig. 10-17).

REACTION TURBINE

The reaction turbine, as the name implies, is turned by reactive force rather than by a direct push or impulse. In reaction turbines, there are no nozzles as such. Instead, the blades that project radially from the periphery of the rotor are formed and mounted so that the spaces between the blades have, in cross section, the shape of nozzles. Since these blades are mounted on the revolving rotor, they are called moving blades.

Fixed or stationary blades of the same shape as the moving blades (fig. 10-18) are fastened to

the stator (casing) in which the rotor revolves. The fixed blades guide the gas into the moving blade system and, since they are also shaped and mounted to provide nozzle-shaped spaces between the blades, the fixed blades also act as nozzles.

A reaction turbine is moved by three main forces: (1) the reactive force produced on the moving blades as the gas increases in velocity as it expands through the nozzle-shaped spaces between the blades; (2) the reactive force produced on the moving blades when the gas changes direction; and (3) the push or impulse of the gas impinging upon the blades. Thus, as previously noted, a reaction turbine is moved primarily by reactive force but also to some extent by direct impulse.

Impulse and reaction blades can be combined to form an impulse-reaction turbine. This turbine combines the rotational forces of the previously described turbines; that is, it derives its rotation from both the impulse of the gas striking the turbine blades and the reactive force of the gas changing direction.

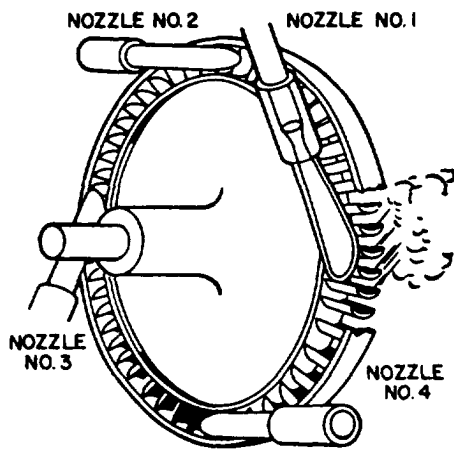

Figure 10-17.—Impulse turbine.

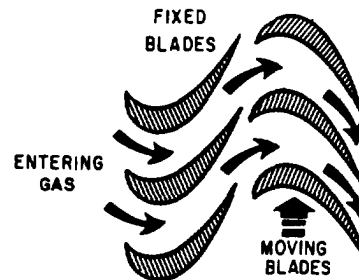

Figure 10-18.—Reaction turbine blading.

CHAPTER 11

PNEUMATICS

The word *pneumatics* is a derivative of the Greek word *pneuma*, which means air, wind, or breath. It can be defined as that branch of engineering science that pertains to gaseous pressure and flow. As used in this manual, pneumatics is the portion of fluid power in which compressed air, or other gas, is used to transmit and control power to actuating mechanisms.

This chapter discusses the origin of pneumatics. It discusses the characteristics of gases and compares them with those of liquids. It also explains factors which affect the properties of gases, identifies and explains the gas laws, and identifies gases commonly used in pneumatics and their pressure ranges. It also discusses hazards of pneumatic gases, methods of controlling contamination, and safety precautions associated with compressed gases.

DEVELOPMENT OF PNEUMATICS

There is no record of man's first uses of air to do work. Probably the earliest uses were to separate chaff from grain and to move ships. One of the first pneumatic devices was the blow gun used by primitive man. In the latter part of the eighteenth century, heated air was used to carry the first balloon aloft. The heated air, being lighter than the surrounding air, caused the balloon to rise.

Every age of man has witnessed the development of devices which used air to do work. However, man used air to do work long before he understood it.

Many of the principles of hydraulics apply to pneumatics. For example, Pascal's law applies to gases as well as liquids. Also, like hydraulics, the development of pneumatics depended on closely fitted parts and the development of gaskets and packings. Since the invention of the air compressor, pneumatics has become a very reliable way to transmit power.

Probably one of the most common uses of pneumatic power is in the operation of pneumatic tools. However, you should understand that pneumatics is also of great importance in large and complex systems such as the controls of vital propulsion and weapon systems.

CHARACTERISTICS OF GASES

Recall from chapter 1 that gas is one of the three states of matter. It has characteristics similar to those of liquids in that it has no definite shape but conforms to the shape of its container and readily transmits pressure.

Gases differ from liquids in that they have no definite volume. That is, regardless of the size or shape of the containing vessel, a gas will completely fill it. Gases are highly compressible, while liquids are only slightly so. Also, gases are lighter than equal volumes of liquids, making gases less dense than liquids.

DENSITY

Early experiments were conducted concerning the behavior of air and similar gases. These experiments were conducted by scientists such as Boyle and Charles (discussed later in this chapter). The results of their experiments indicated that the gases' behavior follows the law known as the *ideal-gas law*. It states as follows: *For a given weight of any gas, the product of the absolute pressure and the volume occupied, divided by the absolute temperature, is constant.* In equation form, it is expressed as follows:

$$\frac{p_1 V_1}{T_1} = \frac{p_2 V_2}{T_2} = \frac{pV}{T} \quad \text{Equation 11-1}$$

For 1 pound of gas,

$$\frac{p_1 V_1}{T_1} = \frac{p_2 V_2}{T_2} = \frac{pV}{T} = R \text{ (a constant),} \quad \text{Equation 11-2}$$

also,

$$pv = RT, \quad \text{Equation 11-}$$

where:

p = absolute pressure

V = total volume

v = specific volume

T = absolute temperature

R = gas constant.

The specific volume (v) is expressed in cubic feet per pound.

For any weight of a gas this equation maybe modified as follows:

W = weight of the gas in pounds,

V = volume of W pounds of the gas in cubic feet.

The volume of 1 pound would then be V/W . If we substitute this for v in equation 11-3, it then becomes

$$p \frac{V}{W} = RT \text{ or } pV = WRT. \quad \text{Equation 11-4}$$

Solving equation 11-4 for pressure,

$$p = \frac{WRT}{V}. \quad \text{Equation 11-5}$$

In chapter 2 we defined density as the mass per unit volume. In equation 11-5,

$$\frac{W}{V}$$

represents density. (Notice that this is the reverse of the specific volume.) We can now say that pressure is equal to the density of the gas times the gas constant times the absolute temperature of the gas. (The gas constant varies for different gases.) From this equation we can show how density varies with changes in pressure and temperature. Decreasing the volume, with the weight of the gas and the temperature held constant, causes the pressure to increase.

NOTE: During the compression of the gas, the temperature will actually increase; however, the explanation is beyond the scope of this text.

Also, since density equals

$$\frac{W}{V},$$

a decrease in volume with the weight held constant will cause density to increase.

TEMPERATURE

As indicated previously, temperature is a dominant factor affecting the physical properties of gases. It is of particular concern in calculating changes in the states of gases.

Three temperature scales are used extensively in gas calculations. They are the Celsius (C), the Fahrenheit (F), and the Kelvin (K) scales. The Celsius (or centigrade) scale is constructed by identifying the freezing and boiling points of water, under standard conditions, as fixed points of 0° and 100° , respectively, with 100 equal divisions between. The Fahrenheit scale identifies 32° as the freezing point of water and 212° as the boiling point, and has 180 equal divisions between. The Kelvin scale has its zero point equal to -273°C , or -460°F .

Absolute zero, one of the fundamental constants of physics, is commonly used in the study of gases. It is usually expressed in terms of the Celsius scale. If the heat energy of a gas sample could be progressively reduced, some temperature should be reached at which the motion of the molecules would cease entirely. If accurately determined, this temperature could then be taken as a natural reference, or as a true absolute zero value.

Experiments with hydrogen indicated that if a gas were cooled to -273.16°C (-273° for most calculations), all molecular motion would cease and no additional heat could be extracted. Since this is the coldest temperature to which an ideal gas can be cooled, it is considered to be absolute zero. Absolute zero may be expressed as 0°K , -273°C , or -459.69°F (-460°F for most calculations).

When you work with temperatures, always be sure which system of measurement is being used and how to convert from one to another. The conversion formulas are shown in figure 11-1. For purposes of calculations, the Rankine (R) scale illustrated in figure 11-1 is commonly used to

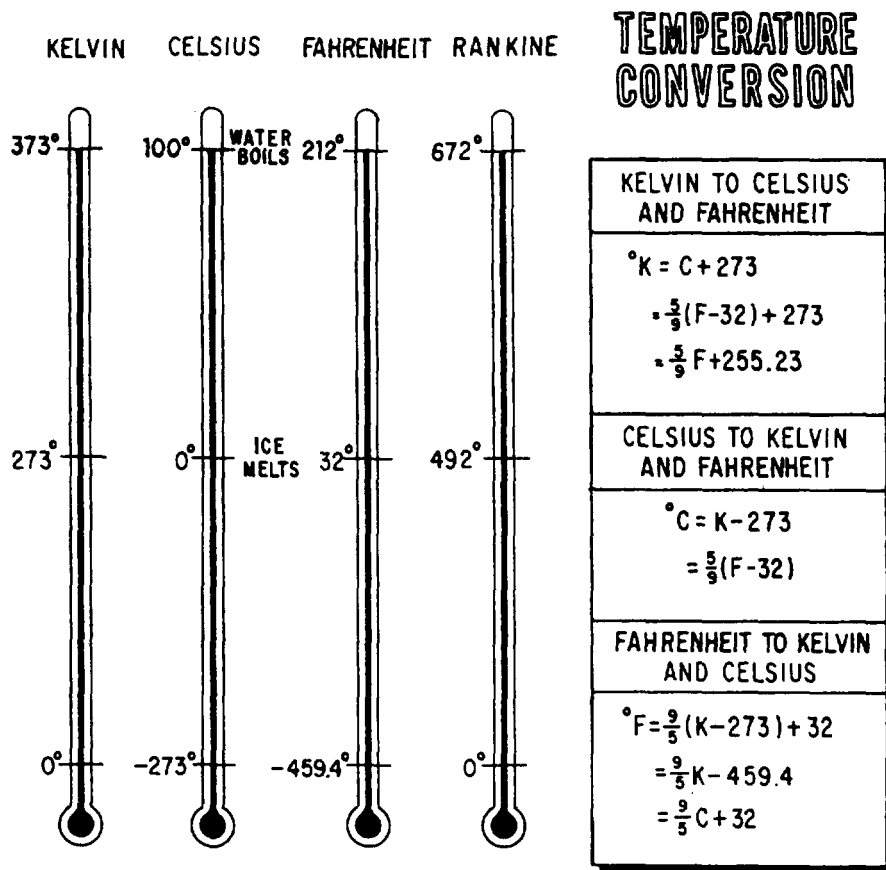

Figure 11-1.-Comparison of Kelvin, Celsius, Fahrenheit, and Rankine temperature.

convert Fahrenheit to absolute. For Fahrenheit readings above zero, 460° is added. Thus, 72°F equals 460° plus 72°, or 532° absolute (532°R). If the Fahrenheit reading is below zero, it is subtracted from 460°. Thus, -40°F equals 460° minus 40°, or 420° absolute (420°R).

The Kelvin and Celsius scales are used internationally in scientific measurements; therefore, some technical manuals may use these scales in directions and operating instructions. The Fahrenheit scale is commonly used in the United States; therefore, it is used in most areas of this manual.

PRESSURE

We defined pressure in chapter 2 as force per unit area. Remember, liquids exert pressure on all surfaces with which they come in contact. Gases, because of their ability to completely fill containers, exert pressure on all sides of a container.

In practice, we may be interested in either of two pressure readings. We may desire either the gauge pressure or the absolute pressure.

Absolute pressure is measured from absolute zero pressure rather than from normal or atmospheric pressure (approximately 14.7 psi). Gauge pressure is used on all ordinary gauges, and indicates pressure in excess of atmospheric pressure. Therefore, absolute pressure is equal to atmospheric pressure plus gauge pressure. For example, 100 psi gauge pressure (psig) equals 100 psi plus 14.7 psi or 114.7 psi absolute pressure (psia). Whenever gas laws are applied, absolute pressures are required.

COMPRESSIBILITY AND EXPANSION OF GASES

Gases can be readily compressed and are assumed to be perfectly elastic. This combination of properties gives a gas the ability to yield to a

force and return promptly to its original condition when the force is removed. These are the properties of air that is used in pneumatic tires, tennis balls and other deformable objects whose shapes are maintained by compressed air.

KINETIC THEORY OF GASES

In an attempt to explain the compressibility of gases, Bernoulli proposed the hypothesis that is accepted as the *kinetic theory of gases*. According to this theory, the pressure exerted by a gas on the walls of a closed container is caused by continual bombardment of the walls by molecules of the gas.

Consider the container shown in figure 11-2 as containing a gas. At any given time, some molecules are moving in one direction, some are traveling in other directions; some are traveling fast, some slow, and some may even be in a state of rest. The average effect of the molecules bombarding each container wall corresponds to the pressure of the gas.

As more gas is pumped into the container, more molecules are available to bombard the walls; thus the pressure in the container increases.

The gas pressure in a container can also be increased by increasing the speed with which the molecules hit the walls. If the temperature of the gas is raised, the molecules move faster causing an increase in pressure. This can be shown by considering the automobile tire. When you take a long drive on a hot day, the pressure in the tires increases and a tire which appeared to be somewhat "soft" in cool morning temperature may appear normal at a higher midday temperature.

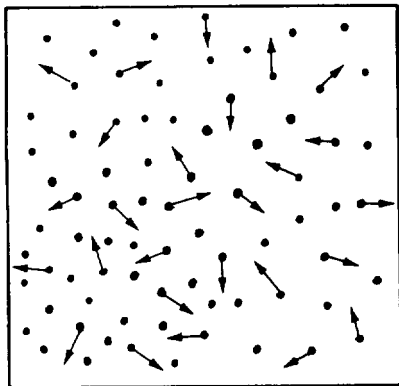

Figure 11-2.—Molecular bombardment creating pressure.

BOYLE'S LAW

When the automobile tire is initially inflated, air which normally occupies a specific volume is compressed into a smaller volume inside the tire. This increases the pressure on the inside of the tire.

Charles Boyle, an English scientist, was among the first to experiment with the pressure-volume relationship of gas. During an experiment when he compressed a volume of air he found that the volume decreased as the pressure increased, and by doubling the force exerted on the air he could decrease the volume of the air by half. See figure 11-3. Recall from the example of the automobile tire that changes in temperature of a gas also change the pressure and volume. Therefore, the experiment must be performed at a constant temperature. The relationship between pressure and volume is known as *Boyle's law*. It states: *When the temperature of a gas is kept constant, the volume of an enclosed gas varies inversely with its pressure.*

In equation form, this relationship may be expressed as either

$$V_1 P_1 = V_2 P_2$$

or

Equation 11-6

$$\frac{V_1}{V_2} = \frac{P_2}{P_1},$$

where V_1 and P_1 are the original volume and pressure, and V_2 and P_2 are the final volume and pressure (P_1 and P_2 are absolute pressures).

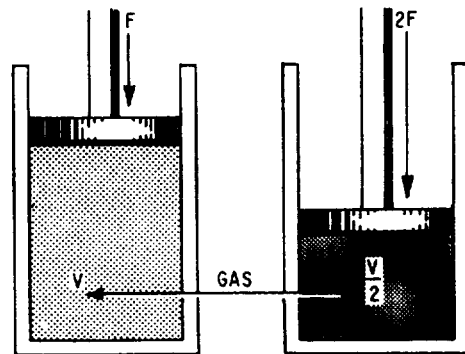

Figure 11-3.—Gas compressed to half its original volume by a doubled force.

Example of Boyle's law: 4 cubic feet of nitrogen are under a pressure of 100 psi (gauge). The nitrogen is allowed to expand to a volume of 6 cubic feet. What is the new gauge pressure? Remember to convert gauge pressure to absolute pressure by adding 14.7.

Using equation 11-6, $V_1P_1 = V_2P_2$, where V_1 is 4 ft³, V_2 is 6 ft, and P_1 is 100 psig:

Solution:

$$V_1P_1 = V_2P_2$$

$$P_2 = \frac{V_1P_1}{V_2}$$

Substituting:

$$P_2 = \frac{4(100 + 14.7)}{6}$$

$$= 76.47 \text{ psia}$$

Converting absolute pressure to gauge pressure:

$$\begin{array}{r} 76.47 \\ -14.7 \\ \hline 61.77 \text{ psi gauge pressure} \end{array}$$

CHARLES'S LAW

Boyle's law assumes conditions of constant temperature. In actual situations this is rarely the case. Temperature changes continually and affects the volume of a given mass of gas.

Jacques Charles, a French physicist, provided much of the foundation for the modern kinetic theory of gases. Through experiments, he found that all gases expand and contract proportionally to the change in the absolute temperature, providing the pressure remains constant. The relationship between volume and temperature is known as *Charles's law*. It states: *The volume of a gas is proportional to its absolute temperature, if constant pressure is maintained.* In equation form, this relationship may be expressed as

$$\text{Equation 11-7}$$

or

$$\frac{V_1}{V_2} = \frac{T_1}{T_2},$$

where V_1 and V_2 are the original and final volumes, and T_1 and T_2 are the original and final absolute temperatures.

Since an increase in the temperature of a gas causes it to expand if the pressure is kept constant, it is reasonable to expect that if a given sample is heated within a closed container and its volume remains constant, the pressure of the gas will increase. Experiments have proven this to be true. In equation form, this becomes

$$P_1T_2 = P_2T_1 \quad \text{Equation 11-8}$$

or

$$\frac{P_1}{P_2} = \frac{T_1}{T_2}.$$

This equation states that for a constant volume, the absolute pressure of a gas varies directly with the absolute temperature.

Example: A cylinder of gas under a pressure of 1800 psig at 70°F is left out in the sun in the tropics and heats up to a temperature of 130°F. What is the new pressure within the cylinder? (Remember that both pressure and temperature must be converted to absolute pressure and absolute temperature.)

Using equation 11-8, $P_1T_2 = P_2T_1$, when P_1 is 1800 psig, T_1 is 70°F, and $T_2 = 130°F$:

Solution:

$$P_1T_2 = P_2T_1; \quad P_2 = \frac{P_1T_2}{T_1}$$

Substituting:

$$P_2 = \frac{(1800 + 14.7) \times (130^\circ + 460^\circ)}{70^\circ + 460^\circ}$$

$$= \frac{1814.7 \times 590}{530}$$

$$P_2 = 2020 \text{ psia}$$

Converting absolute pressure to gauge pressure:

$$\begin{array}{r} 2020.0 \\ -14.7 \\ \hline 2005.3 \text{ psig} \end{array}$$

GENERAL GAS LAW

We have learned that Boyle's law pertains to situations in which the temperature remains constant (fig. 11-4), and that Charles's law pertains to situations in which pressure remains constant (fig. 11-4). It is usually not possible to control pressure or temperature in tanks or bottles of gas subject to the weather and shipboard demands. Boyle's and Charles's laws are combined to form the *general gas law*. This law states: *The product of the initial pressure, initial volume, and new temperature (absolute scale) of an enclosed gas is equal to the product of the new pressure, new volume, and initial temperature.* It is a mathematical statement which allows many gas problems to be solved by using the principles of Boyle's law and/or Charles's law. The equation is expressed as

$$P_1 V_1 T_2 = P_2 V_2 T_1 \quad \text{Equation 11-9}$$

or

$$\frac{P_1 V_1}{T_1} = \frac{P_2 V_2}{T_2}.$$

(P and T represent absolute pressure and absolute temperature, respectively.)

You can see by examining figure 11-4 that the three equations are special cases of the general equation. Thus, if the temperature remains constant, T_1 equals T_2 and both can be eliminated from the general formula, which then reduces to the form shown in part A. When the volume remains constant, V_1 equals V_2 , thereby reducing

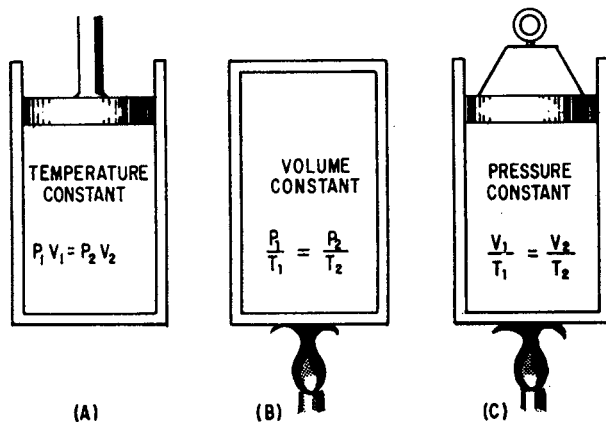

Figure 11-4.—The general gas law.

the general equation to the form given in part B. Similarly, P_1 is equated to P_2 for constant pressure, and the equation then takes the form given in part C.

The general gas law applies with exactness only to "ideal" gases in which the molecules are assumed to be perfectly elastic. However, it describes the behavior of actual gases with sufficient accuracy for most practical purposes.

Two examples of the general equation follow:

1. Two cubic feet of a gas at 75 psig and 80°F are compressed to a volume of 1 cubic foot and then heated to a temperature of 300°F. What is the new gauge pressure?

Using equation 11-9, $P_1 V_1 T_2 = P_2 V_2 T_1$, where V_1 is 2 ft³, P_1 is 75 psig, T_1 is 80°F, V_2 is 1 ft³ and T_2 is 300°F:

Solution:

$$P_1 V_1 T_2 = P_2 V_2 T_1$$

$$P_2 = \frac{P_1 V_1 T_2}{V_2 T_1}$$

Substituting:

$$\begin{aligned} P_2 &= \frac{(75 + 14.7) (2) (300 + 460)}{(1) (80 + 460)} \\ &= \frac{(89.7) (2) (760)}{(1) (540)} \\ &= \frac{(179.4) (760)}{(540)} \end{aligned}$$

$$P_2 = 252.5 \text{ psia}$$

Converting absolute pressure to gauge pressure:

$$\begin{array}{r} 252.5 \\ -14.7 \\ \hline 237.8 \text{ psig} \end{array}$$

2. Four cubic feet of a gas at 75 psig and 80°F are compressed to 237.8 psig and heated to a temperature of 300°F. What is the volume of the gas resulting from these changes? Using equation 11-9, $P_1 V_1 T_2 = P_2 V_2 T_1$, where V_1 is 4 ft³, P_2 is

75 psig, T_1 is 800, P_1 is 237.8 psig, and T_2 is 300°F:

Solution:

$$P_1 V_1 T_2 = P_2 V_2 T_1$$

$$V_2 = \frac{P_1 V_1 T_2}{P_2 T_1}$$

Substituting:

$$\begin{aligned} V_2 &= \frac{(75 + 14.7) (4) (300 + 460)}{(237.8 + 14.7) (80 + 460)} \\ &= \frac{(89.7) (4) (760)}{(252.5) (540)} \end{aligned}$$

$$V_2 = 2 \text{ cubic feet}$$

PNEUMATIC GASES

In chapter 1, you learned that many factors are considered in determining whether to use hydraulics or pneumatics as a power source in a fluid power system. Once it is determined that pneumatics will be used as the source of power, some of the same factors are considered in selecting the pneumatic gas.

QUALITIES

The ideal fluid medium for a pneumatic system is a readily available gas that is nonpoisonous (nontoxic), chemically stable, free from any acids that cause corrosion of system components, and nonflammable. It also will not support combustion of other elements.

Gases that have these desired qualities may not have the required lubricating power. Therefore, lubrication of the components of some pneumatic systems must be arranged by other means. For example, some air compressors are provided with a lubricating system, some components are lubricated upon installation or, in some cases, lubrication is introduced into the air supply line.

Two gases meeting these qualities and most commonly used in pneumatic systems are compressed air and nitrogen.

COMPRESSED AIR

Compressed air is a mixture of all gases contained in the atmosphere. In this manual,

compressed air is referred to as a gas when it is used as a fluid medium.

The unlimited supply of air and the ease of compression make compressed air the most widely used fluid for pneumatic systems. Although moisture and solid particles must be removed from the air, it does not require the extensive distillation or separation process required in the production of other gases.

Compressed air has most of the desired properties and characteristics of a gas for pneumatic systems. It is nonpoisonous and nonflammable but does contain oxygen, which supports combustion. One of the most undesirable qualities of compressed air as a fluid medium for pneumatic systems is moisture content. The atmosphere contains varying amounts of moisture in vapor form. Changes in the temperature of compressed air will cause condensation of moisture in the pneumatic system. This condensed moisture can be very harmful to the system, as it increases corrosion, dilutes lubricants, and may freeze in lines and components during cold weather. Moisture separators and air driers (dehydrators) are installed in the compressed air lines to minimize or eliminate moisture in systems where moisture would deteriorate system performance.

The supply of compressed air at the required volume and pressure is provided by an air compressor. (For information on air compressors, refer to *Naval Ships' Technical Manual*, chapter 551.) In most systems the compressor is part of the system with distribution lines leading from the compressor to the devices to be operated. In these systems a receiver is installed in-line between the compressor and the device to be operated to help eliminate pulsations in the compressor discharge line, to act as a storage tank during intervals when the demand for air exceeds the compressor's capacity, and to enable the compressor to shut down during periods of light load. Other systems receive their supply from cylinders which must be filled at a centrally located air compressor and then connected to the system.

Compressed air systems are categorized by their operating pressures as follows: high-pressure (HP) air, medium-pressure (MP) air, and low-pressure (LP) air.

High-Pressure Air Systems

HP air systems provide compressed air at a nominal operating pressure of 3000 psi or 5000 psi and are installed whenever pressure in excess

of 1000 psi is required. HP compressed air plants support functions which require high pressures and high flow rates of compressed air by the addition of HP storage flasks to the system. An example of such a system is one that provides air for starting diesel and gas turbine engines. Reduction in pressure, if required, is done by using specially designed pressure-reducing stations.

Medium-Pressure Air

MP air systems provide compressed air at a nominal operating pressure of 151 psi to 1000 psi. These pressures are provided either by an MP air compressor or by the HP air system supplying air through an air bank and pressure-reducing stations.

Low-Pressure Air

LP air systems provide compressed air at a nominal operating pressure of 150 psi and below. The LP air system is supplied with LP air by LP air compressors or by the HP air system supplying air through an air bank and pressure-reducing stations. LP air is the most extensive and varied air system used in the Navy.

In addition to being used for various pneumatic applications, LP and HP compressed air are used in the production of nitrogen.

NITROGEN

For all practical purposes, nitrogen is considered to be an inert gas. It is nonflammable, does not form explosive mixtures with air or oxygen, and does not cause rust or decay. Due to these qualities, its use is preferred over compressed air in many pneumatic systems, especially aircraft and missile systems, and wherever an inert gas blanket is required.

Nitrogen is obtained by the fractional distillation of air. Oxygen/nitrogen-producing plants expand compressed air until its temperature decreases to -196°C (-320°F), the boiling point of nitrogen at atmospheric pressure. The liquid nitrogen is then directed to a storage tank. A liquid nitrogen pump pumps the low-pressure liquid nitrogen from the storage tank and discharges it as a high-pressure (5000 psi) liquid to the vaporizer where it is converted to a gas at 5000 psi. Oxygen/nitrogen-producing plants are located at many naval installations and on submarine tenders and aircraft carriers.

CONTAMINATION CONTROL

As in hydraulic systems, fluid contamination is also a leading cause of malfunctions in pneumatic systems. In addition to the solid particles of foreign matter which find a way to enter the system, there is also the problem of moisture. Most systems are equipped with one or more devices to remove this contamination. These include filters, water separators, air dehydrators, and chemical driers, which are discussed in chapter 9 of this manual. In addition, most systems contain drain valves at critical low points in the system. These valves are opened periodically to allow the escaping gas to purge a large percentage of the contaminants, both solids and moisture, from the system. In some systems these valves are opened and closed automatically, while in others they must be operated manually.

Complete purging is done by removing lines from various components throughout the system and then attempting to pressurize the system, causing a high rate of airflow through the system. The airflow will cause the foreign matter to be dislodged and blown from the system.

NOTE: If an excessive amount of foreign matter, particularly oil, is blown from any one system, the lines and components should be removed and cleaned or replaced.

In addition to monitoring the devices installed to remove contamination, it is your responsibility as a maintenance person or supervisor to control the contamination. You can do this by using the following maintenance practices:

1. Keep all tools and the work area in a clean, dirt-free condition.
2. Cap or plug all lines and fittings immediately after disconnecting them.
3. Replace all packing and gaskets during assembly procedures.
4. Connect all parts with care to avoid stripping metal slivers from threaded areas. Install and torque all fittings and lines according to applicable technical instructions.
5. Complete preventive maintenance as specified by MRCs.

Also, you must take care to ensure that the proper cylinders are connected to systems being supplied from cylinders.

Cylinders for compressed air are painted black. Cylinders containing oil-pumped air have

two green stripes painted around the top of the cylinder, while cylinders containing water-pumped air have one green stripe. Oil-pumped air indicates that the air or nitrogen is compressed by an oil-lubricated compressor. Air or nitrogen compressed by a water-lubricated (or nonlubricated) compressor is referred to as water pumped. Oil-pumped nitrogen can be very dangerous in certain situations. For example, nitrogen is commonly used to purge oxygen systems. Oxygen will not burn, but it supports and accelerates combustion and will cause oil to burn easily and with great intensity. Therefore, oil-pumped nitrogen must never be used to purge oxygen systems. When the small amount of oil remaining in the nitrogen comes in contact with the oxygen, an explosion may result. In all situations, use only the gas specified by the manufacturer or recommended by the Navy. Nitrogen cylinders are painted gray. One black stripe identifies cylinders for oil-pumped nitrogen, and two black stripes identify cylinders for water-pumped nitrogen. In addition to these color codes, the exact identification of the contents is printed in two locations diametrically opposite one another along the longitudinal axis of the cylinder. For compressed air and nitrogen cylinders, the lettering is white.

POTENTIAL HAZARDS

All compressed gases are hazardous. Compressed air and nitrogen are neither poisonous nor flammable, but should not be handled carelessly. Some pneumatic systems operate at pressures exceeding 3000 psi. Lines and fittings have exploded, injuring personnel and property. Literally thousands of careless workers have blown dust or harmful particles into their eyes by the careless handling of compressed air outlets.

Nitrogen gas will not support life, and when it is released in a confined space, it will cause asphyxia (the loss of consciousness as a result of too little oxygen and too much carbon dioxide in

the blood). Although compressed air and nitrogen seem so safe in comparison with other gases, do not let overconfidence lead to personal injury.

SAFETY PRECAUTIONS

To minimize personal injury and equipment damage when using compressed gases, observe all practical operating safety precautions, including the following:

1. Do not use compressed air to clean parts of your body or clothing, or to perform general space cleanup in lieu of vacuuming or sweeping.

2. Never attempt to stop or repair a leak while the leaking portion is still under pressure. Always isolate, repressurize and danger tag out the portion of the system to be repaired. For pressures of 1000 psi or greater, double valve protection is required to prevent injury if one of the valves should fail.

3. Avoid the application of heat to the air piping system or components, and avoid striking a sharp or heavy blow on any pressurized part of the piping system.

4. Avoid rapid operation of manual valves. The heat of compression caused by a sudden high-pressure flow into an empty line or vessel can cause an explosion if oil is present. Valves should be slowly cracked open until airflow is noted and should be kept in this position until pressures on both sides of the valve have equalized. The rate of pressure rise should be kept under 200 psi per second, if possible. Valves may then be opened fully.

5. Do not discharge large quantities of nitrogen into closed compartments unless adequate ventilation is provided.

6. Do not subject compressed gas cylinders to temperatures greater than 130°F.

Remember, any pressurized system can be hazardous to your health if it is not maintained and operated carefully and safely.

CHAPTER 12

BASIC DIAGRAMS AND SYSTEMS

In the preceding chapters, you learned about hydraulic and pneumatic fluids and components of fluid power systems. While having a knowledge of system components is essential, it is difficult to understand the interrelationship of these components by simply watching the system operate. The knowledge of system interrelation is required to effectively troubleshoot and maintain a fluid power system. Diagrams provided in applicable technical publications or drawings are a valuable aid in understanding the operation of the system and in diagnosing the causes of malfunctions.

This chapter explains the different types of diagrams used to illustrate fluid power circuits, including some of the symbols that depict fluid power components. Included in this chapter are descriptions and illustrations denoting the differences between open-center and closed-center fluid power systems. The last part of the chapter describes and illustrates some applications of basic fluid power systems.

DIAGRAMS

As mentioned earlier in this chapter, to troubleshoot fluid power systems intelligently, a mechanic or technician must be familiar with the system on which he or she is working. The mechanic must know the function of each component in the system and have a mental picture of its location in relation to other components. This can best be done by studying the diagrams of the system.

A diagram may be defined as a graphic representation of an assembly or system that indicates the various parts and expresses the methods or principles of operations. The ability to read diagrams is a basic requirement for understanding the operation of fluid power systems. Understanding the diagrams of a system requires having a knowledge of the symbols used in the schematic diagrams.

SYMBOLS

The Navy uses two military standards that list mechanical symbols that must be used in preparing drawings that will contain symbolic representation. These standards are as follows:

1. *Military Standard, Mechanical Symbols (Other than Aeronautical, Aerospacecraft, and Spacecraft Use), Part 1, MIL-STD-17B-1.*
2. *Military Standard, Mechanical Symbols for Aeronautical, Aerospacecraft, and Spacecraft Use, Part 2, MIL-STD-17B-2.*

Some of the symbols frequently used in fluid power systems have been selected from these two standards and are shown in Appendixes II and III. Appendix II contains symbols from MIL-STD-17B-1. Appendix III contains symbols from MIL-STD-17B-2.

While the symbols shown in the appendixes are not all encompassing, they do provide a basis for an individual working with fluid power systems to build upon. Some rules applicable to graphical symbols for fluid diagrams are as follows:

1. Symbols show connections, flow paths, and the function of the component represented only. They do not indicate conditions occurring during transition from one flow path to another; nor do they indicate component construction or values, such as pressure or flow rate.
2. Symbols do not indicate the location of ports, direction of shifting of spools, or position of control elements on actual components.
3. Symbols may be rotated or reversed without altering their meaning except in cases of lines to reservoirs and vented manifolds.
4. Symbols may be drawn in any size.
5. Each symbol is drawn to show the normal or neutral condition of each component unless multiple circuit diagrams are furnished showing various phases of circuit operation.

For more detailed information concerning the symbols used in fluid power diagrams, consult the above-mentioned military standards. Additional information concerning symbols and the reading of diagrams is contained in *Blueprint Reading and Sketching*, NAVEDTRA 10077-F1.

TYPES OF DIAGRAMS

There are many types of diagrams. Those that are most pertinent to fluid power systems are discussed in this text.

Pictorial Diagrams

Pictorial diagrams (fig. 12-1) show the general location and actual appearance of each

component, all interconnecting piping, and the general piping arrangement. This type of diagram is sometimes referred to as an installation diagram. Diagrams of this type are invaluable to maintenance personnel in identifying and locating components of a system.

Cutaway Diagrams

Cutaway diagrams (fig. 12-2) show the internal working parts of all fluid power components in a system. This includes controls and actuating mechanisms and all interconnecting piping. Cutaway diagrams do not normally use symbols.

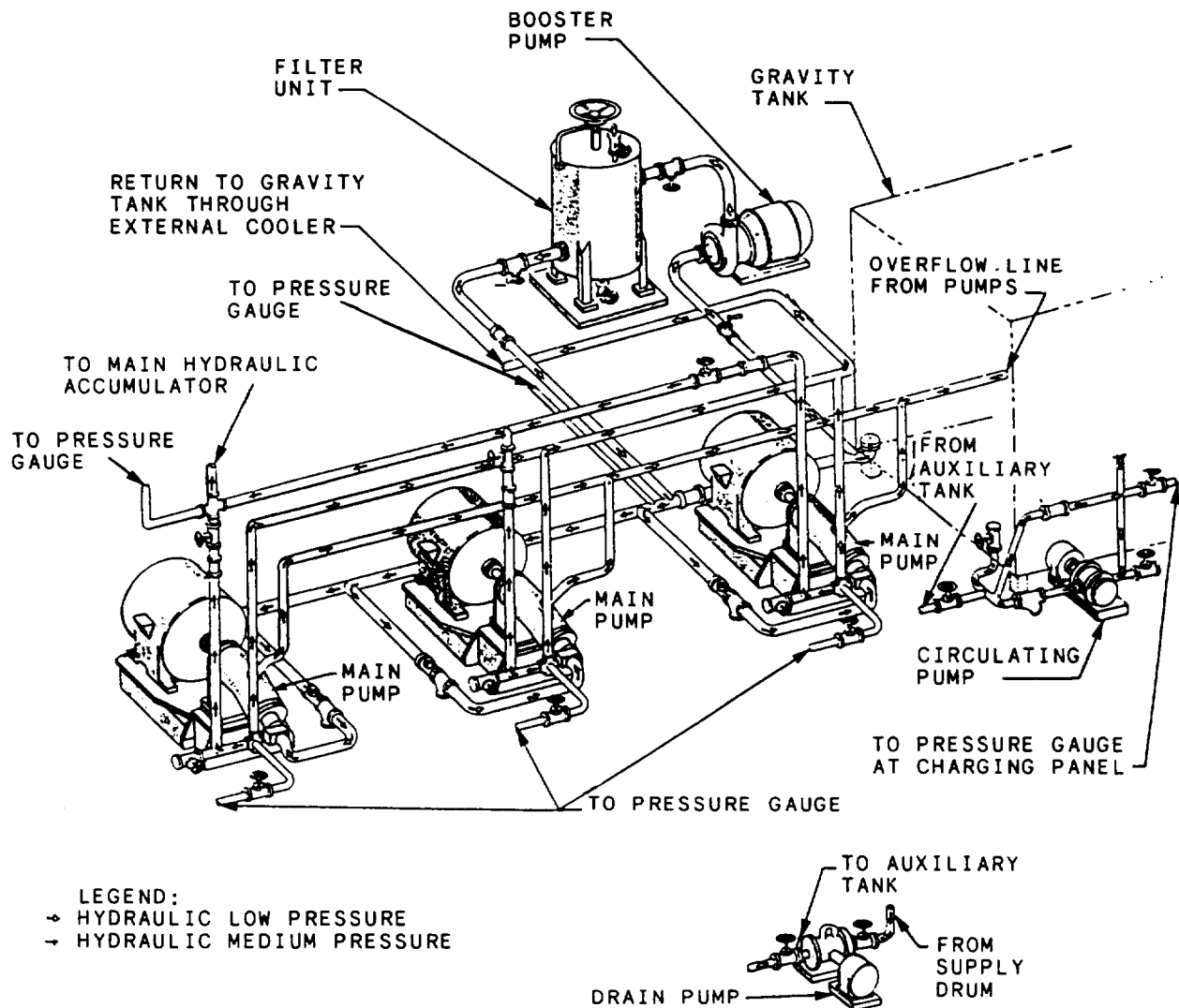

Figure 12-1.—Hydraulic system pictorial diagram.

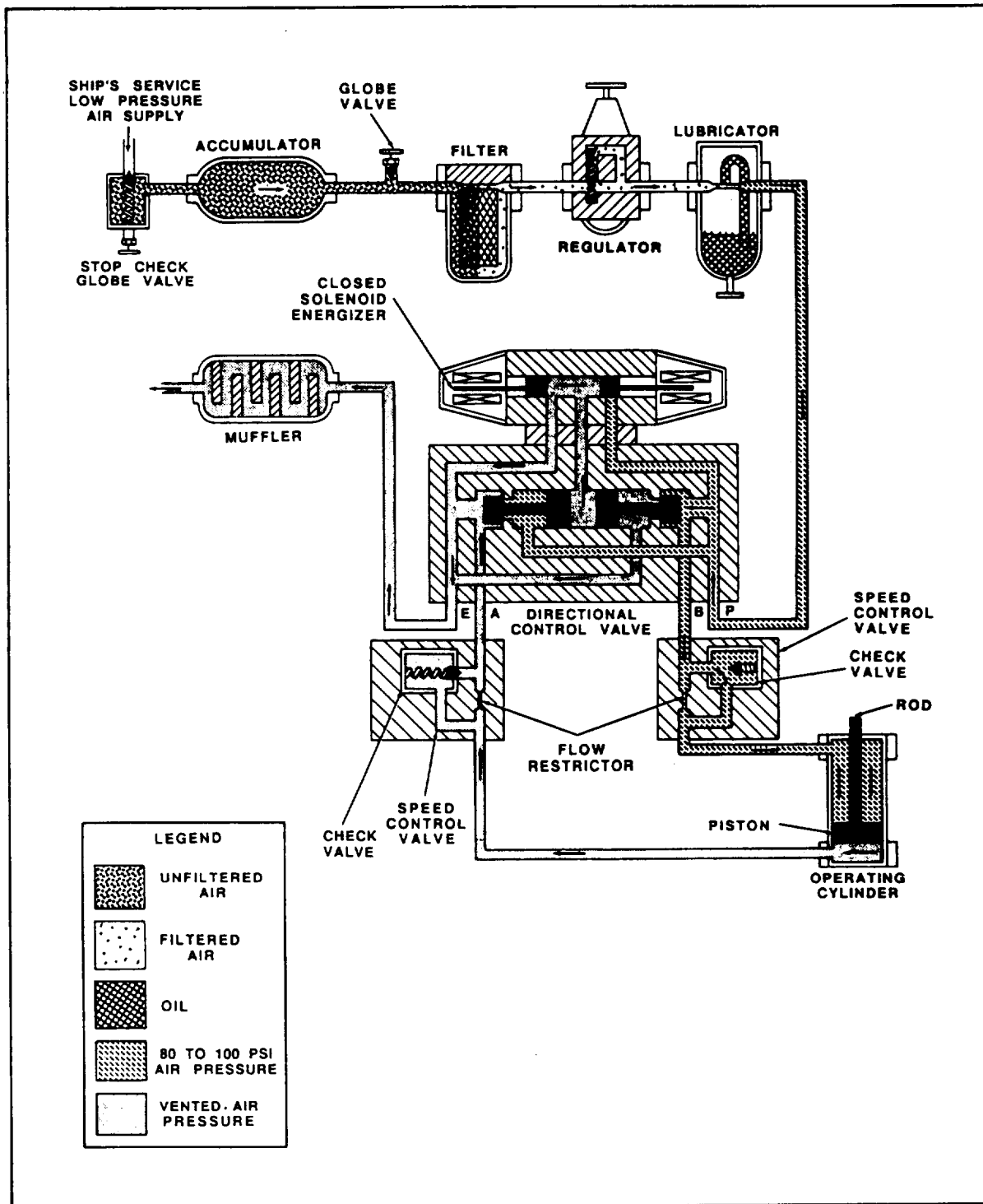
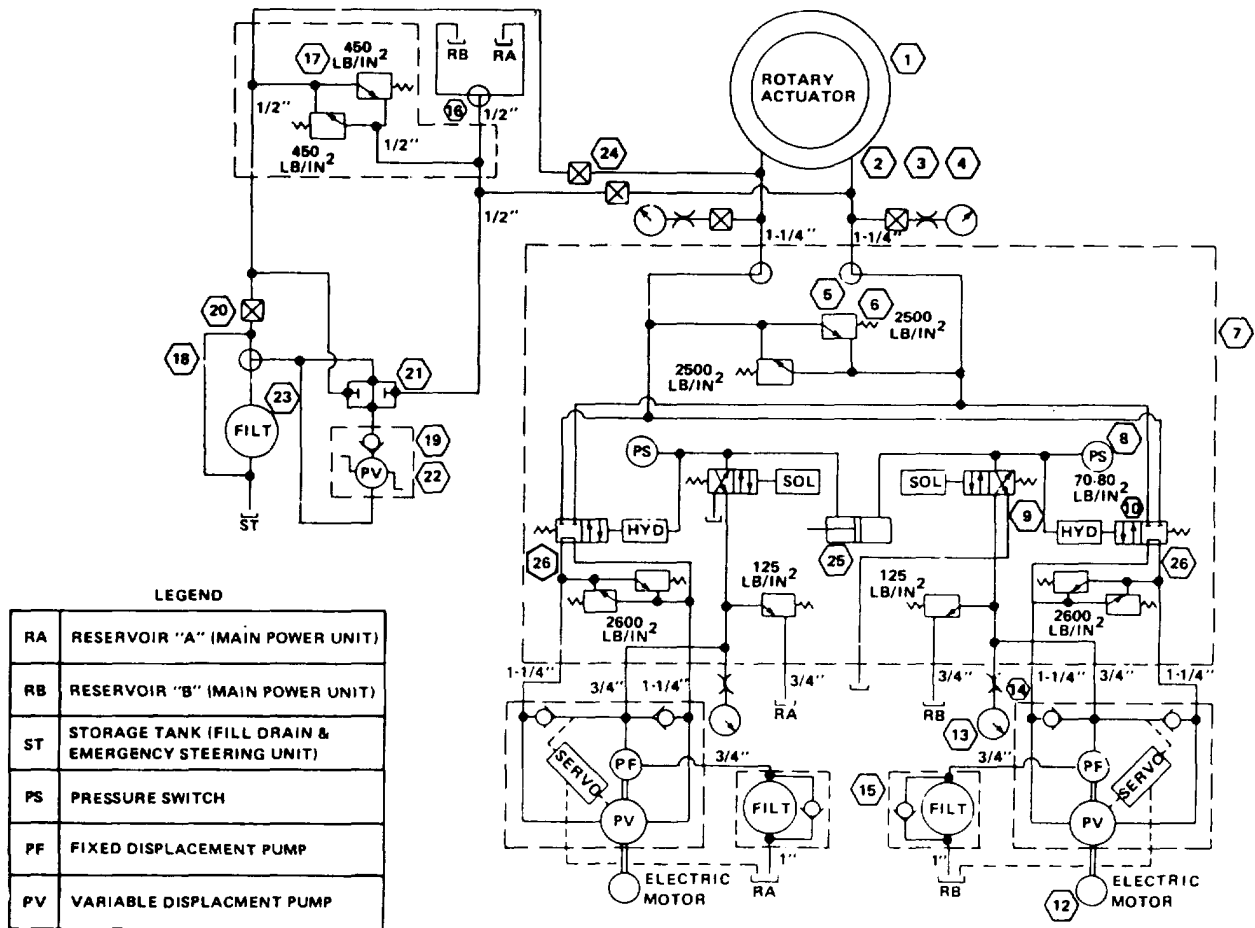

Figure 12-2.—Cutaway diagram—pneumatic.

Graphic Diagrams

The primary purpose of a graphic (schematic) diagram is to enable the maintenance person to trace the flow of fluid from component to component within the system. This type of diagram uses standard symbols to show each component and includes all interconnecting

pipings. Additionally, the diagram contains a component list, pipe size, data on the sequence of operation, and other pertinent information. The graphic diagram (fig. 12-3) does not indicate the physical location of the various components, but it does show the relation of each component to the other components within the system.



- | | | |
|---|---|---|
| 1. Rotary actuator | 10. 3/4-inch pilot-operated 4-way valve | 19. Common check valve with hand pump |
| 2. 1 1/4-inch shutoff valve | 11. None | 20. 1/2-inch shutoff valve |
| 3. 0-5000 psi pressure snubber | 12. Electric motor (see NOTE) | 21. 3/8-inch manual rotary selector valve |
| 4. 0-3000 psi pressure gauge | 13. 0-300 psi pressure gauge | 22. Hand pump |
| 5. Manual 1-inch rotary selector valve | 14. Servo-operated variable-displacement pump | 23. 10-micron filter |
| 6. Pressure control valve | 15. 10-micron filter | 24. Shutoff valve |
| 7. Manifold block | 16. 1/2-inch manual rotary selector valve | 25. LVR/LVP selector cylinder |
| 8. 7-250 psi pressure switch | 17. Pressure control valve | 26. Relief valves |
| 9. 1/4-inch solenoid-operated 4-way valve | 18. 1/2-inch manual rotary selector valve | |

NOTE: Electric Motor is 40 horsepower, 1800 rpm, 440 volts ac, 3 phase, 60 hertz.

Figure 12-3.—Graphic diagram of LST 1182 class hydraulic steering gear.

Notice that figure 12-3 does not indicate the physical location of the individual components with respect to each other in the system. For example, the 3/4-inch, solenoid-operated, 4-way valve (10) is not necessarily located directly above the relief valve (26). The diagram does indicate, however, that the 4-way valve is located in the working line, between the variable-displacement pump and the 1-inch rotary selector valve, and that the valve directs fluid to and from the rotary actuator.

Combination Diagrams

A combination drawing uses a combination of graphic, cutaway, and pictorial symbols. This drawing also includes all interconnecting piping.

FLUID POWER SYSTEMS

A fluid power system in which the fluid in the system remains pressurized from the pump (or regulator) to the directional control valve while the pump is operating is referred to as a closed-center system. In this type of system, any number of subsystems may be incorporated, with a separate directional control valve for each subsystem. The directional control valves are arranged in parallel so that system pressure acts equally on all control valves.

Another type of system that is sometimes used in hydraulically operated equipment is the open-center system. An open-center system has fluid flow but no internal pressure when the actuating mechanisms are idle. The pump circulates the fluid from the reservoir, through the directional control valves, and back to the reservoir. (See fig. 12-4, view A.) Like the closed-center system, the open-center system may have any number of subsystems, with a directional control valve for each subsystem. Unlike the closed-center system, the directional control valves of an open-center system are always connected in series with each other, an arrangement in which the system pressure line goes through each directional control valve. Fluid is always allowed free passage through each control valve and back to the reservoir until one of the control valves is positioned to operate a mechanism.

When one of the directional control valves is positioned to operate an actuating device, as shown in view B of figure 12-4, fluid is directed from the pump through one of the working lines to the actuator. With the control valve in this position, the flow of fluid through the valve to the reservoir is blocked. Thus, the pressure builds up in the system and moves the piston of the

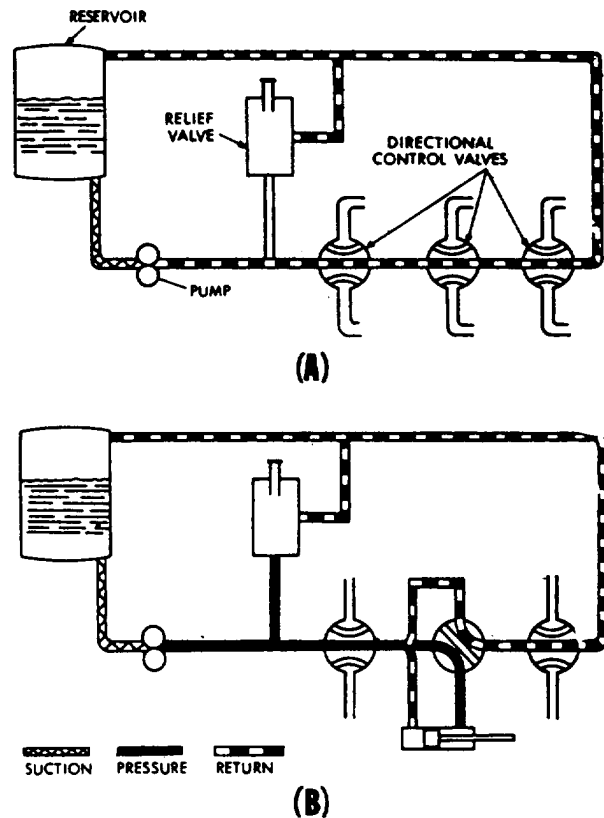

Figure 12-4.—Open-center hydraulic system.

actuating cylinder. The fluid from the other end of the actuator returns to the control valve through the opposite working line and flows back to the reservoir.

Several different types of directional control valves are used in the open-center system. One type is the manually engaged and manually disengaged. After this type of valve is manually moved to the operating position and the actuating mechanism reaches the end of its operating cycle, pump output continues until the system relief valve setting is reached. The relief valve then unseats and allows the fluid to flow back to the reservoir. The system pressure remains at the pressure setting of the relief valve until the directional control valve is manually returned to the neutral position. This action reopens the open-center flow and allows the system pressure to drop to line resistance pressure.

Another type of open-center directional control valve is manually engaged and pressure disengaged. This type of valve is similar to the valve discussed in the preceding paragraph; however, when the actuating mechanism reaches the end of its cycle and the pressure continues to

rise to a predetermined pressure, the valve automatically returns to the neutral position and, consequently, to open-center flow.

One of the advantages of the open-center system is that the continuous pressurization of the system is eliminated. Since the pressure is gradually built up after the directional control valve is moved to an operating position, there is very little shock from pressure surges. This provides a smooth operation of the actuating mechanisms; however, the operation is slower than the closed-center system in which the pressure is available the moment the directional control valve is positioned. Since most applications require instantaneous operation, closed-center systems are the most widely used.

HYDRAULIC POWER DRIVE SYSTEM

The hydraulic power drive has been used in the Navy for many years. Proof of its effectiveness is that it has been used to train and elevate nearly all caliber guns, from the 40-mm gun mount to the 16-inch turret. In addition to gun mounts and turrets, hydraulic power drives are used to position rocket launchers and missile launchers, and to drive and control such equipment as windlasses, capstans, and winches.

In its simplest form, the hydraulic power drive consists of the following:

1. The prime mover, which is the outside source of power used to drive the hydraulic pump
2. A variable-displacement hydraulic pump
3. A hydraulic motor
4. A means of introducing a signal to the hydraulic pump to control its output
5. Mechanical shafting and gearing that transmits the output of the hydraulic motor to the equipment being operated

Hydraulic power drives differ in some respects, such as size, method of control, and so forth. However, the fundamental operating principles are similar. The unit used in the following discussion of fundamental operating principles is representative of the hydraulic power drives used to operate the 5"/38 twin mounts.

Figure 12-5 shows the basic components of the train power drive. The electric motor is constructed with drive shafts at both ends. The forward shaft drives the A-end pump through reduction gears, and the after shaft drives the auxiliary pumps through the auxiliary reduction gears. The reduction gears are installed because

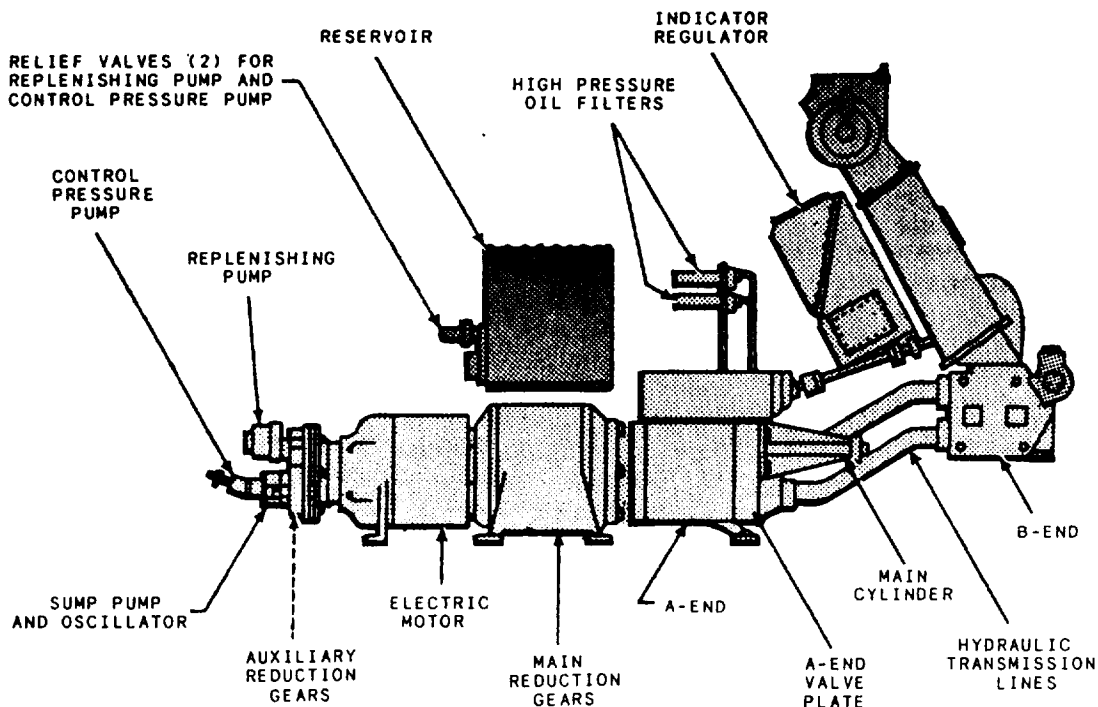

Figure 12-5. Train power drive—components.

the pumps are designed to operate at a speed much slower than that of the motor.

The replenishing pump is a spur gear pump. Its purpose is to replenish fluid to the active system of the power drive. It receives its supply of fluid from the reservoir and discharges it to the B-end valve plate. This discharge of fluid from the pump is held at a constant pressure by the action of a pressure relief valve. (Because the capacity of the pump exceeds replenishing demands, the relief valve is continuously allowing some of the fluid to flow back to the reservoir.)

The sump pump and oscillator has a twofold purpose. It pumps leakage, which collects in the sump of the indicator regulator, to the expansion tank. Additionally, it transmits a pulsating effect to the fluid in the response pressure system. Oscillations in the hydraulic response system help eliminate static friction of valves, allowing hydraulic control to respond faster.

The control pressure pump supplies high-pressure fluid for the hydraulic control system, brake pistons, lock piston, and the hand-controlled clutch operating piston. The control pressure pump is a fixed-displacement, axial-piston type. An adjustable relief valve is used to limit the operating pressure at the outlet of the pump.

Control

For the purpose of this text, control constitutes the relationship between the stroke control shaft and the tilting box. The stroke control shaft is one of the piston rods of a double-acting piston-type actuating cylinder. This actuating cylinder and its direct means of control are referred to as the main cylinder assembly (fig. 12-6). It is the link between the hydraulic followup system and the power drive itself.

In hand control, the tilting box is mechanically positioned by gearing from the handwheel through the A-end control unit. In local and automatic control, the tilting box is positioned by the stroke control shaft. As shown in figure 12-6, the extended end of the control shaft is connected to the tilting box. Movement of the shaft will pivot the tilting box one way or the other; which, in turn, controls the output of the A-end of the transmission. The other end of the shaft is attached to the main piston. A shorter shaft is attached to the opposite side of the piston. This shaft is also smaller in diameter. Thus the working area of the left side of the piston is twice that of the area of the right side, as it appears in figure 12-6.

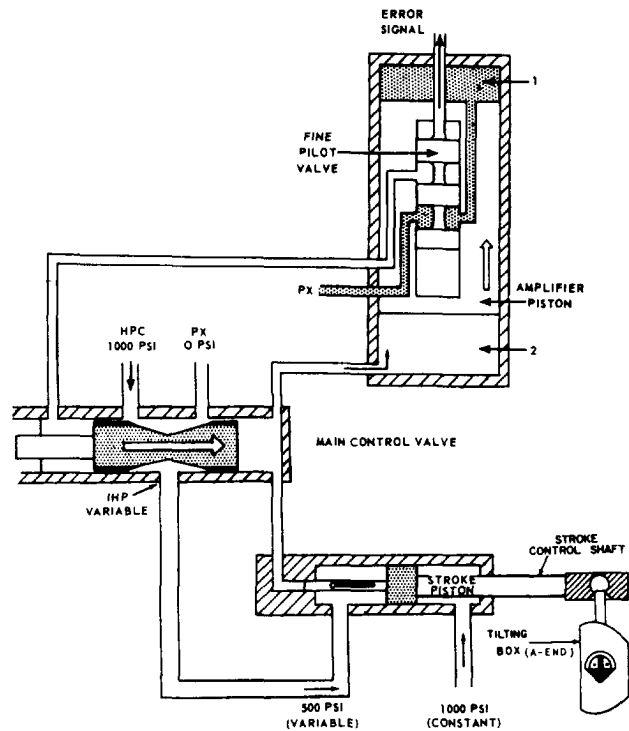

Figure 12-6.-Main cylinder assembly.

Intermediate high-pressure fluid (IHP) is transmitted to the left side of the piston, while high-pressure hydraulic fluid (HPC) is transmitted to the right side. The HPC is held constant at 1000 psi. Since the area of the piston upon which HPC acts is exactly one-half the area upon which IHP acts, the main piston is maintained in a fixed position when IHP is one-half HPC (500 psi). Whenever IHP varies from its normal value of 500 psi, the main piston will move, thus moving the tilting box.

Operation

Assume that a right train order signal is received. This will cause the pilot valve to be pulled upward. The fluid in the upper chamber of the amplifier piston can now flow through the lower land chamber of the fine pilot to exhaust. This will cause the amplifier piston to move upward, and the fluid in the right-hand chamber of the main control valve can flow into the lower chamber of the amplifier valve.

The main control valve will now move to the right, IHP will drop below 500 psi, and the stroke piston will move to the left. Movement of the

stroke piston will cause tilt to be put on the tilt plate, and the A-end will cause the mount to train right.

Figure 12-7 is a simplified block diagram showing the main element of the hydraulic power drive system under automatic control for clockwise and counterclockwise rotation.

There are two principal problems in positioning a gun to fire. One is to get an accurate gun-order signal. This problem is solved by the director-computer combination. The other problem is to transmit the director signal promptly to the gun so that the position and movements of the gun will be synchronized with the signals from the director.

The problem of transforming gun-order signals to mount movements is solved by the power drive and its control—the indicator regulator. The indicator regulator controls the power drive, and this, in turn, controls the movement of the gun.

The indicator regulator receives an initial electrical gun-order from the director-computer, compares it to the existing mount position, and sends an error signal to the hydraulic control mechanism in the regulator. The hydraulic control mechanism controls the flow to the stroking piston, which positions the tilting box in the A-end of the transmission. Its tilt controls the volume and direction of fluid pumped to the B-end and, therefore, the speed and direction of the drive shaft of the B-end. Through mechanical linkage, the B-end output shaft moves the gun in the

direction determined by the signal. At the same time, B-end response is transmitted to the indicator regulator and continuously combines with incoming gun-order signals to give the error between the two. This error is modified hydraulically, according to the system of mechanical linkages and valves in the regulator. When the gun is lagging behind the signal, its movement is accelerated; and when it begins to catch up, its movement is slowed down so that it will not overrun excessively.

LANDING GEAR EMERGENCY SYSTEM

If the landing gear in a naval aircraft fails to extend to the down and locked position, the aircraft has an emergency method to extend the landing gear. This text will cover the nitrogen system.

The nitrogen storage bottle system is a one-shot system powered by nitrogen pressure stored in four compressed nitrogen bottles (fig. 12-8). When the landing gear control handle is used to actuate the emergency landing gear system, a cable between the control and the manually operated nitrogen bottle opens the emergency gear down release valve on the bottle. Nitrogen from this bottle actuates the release valves on the other three bottles so that they discharge. Nitrogen flows from the manually operated bottle, actuates the dump valves, and causes the shuttles within the shuttle valves on the

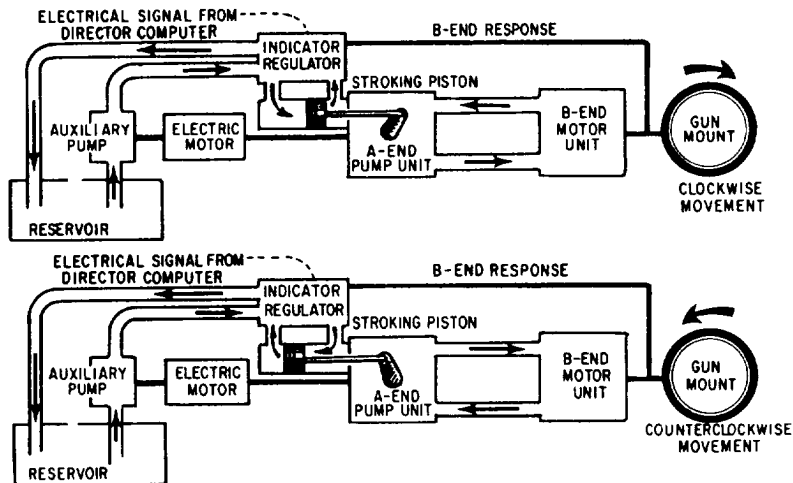

Figure 12-7.—Operation of the hydraulic power drive.

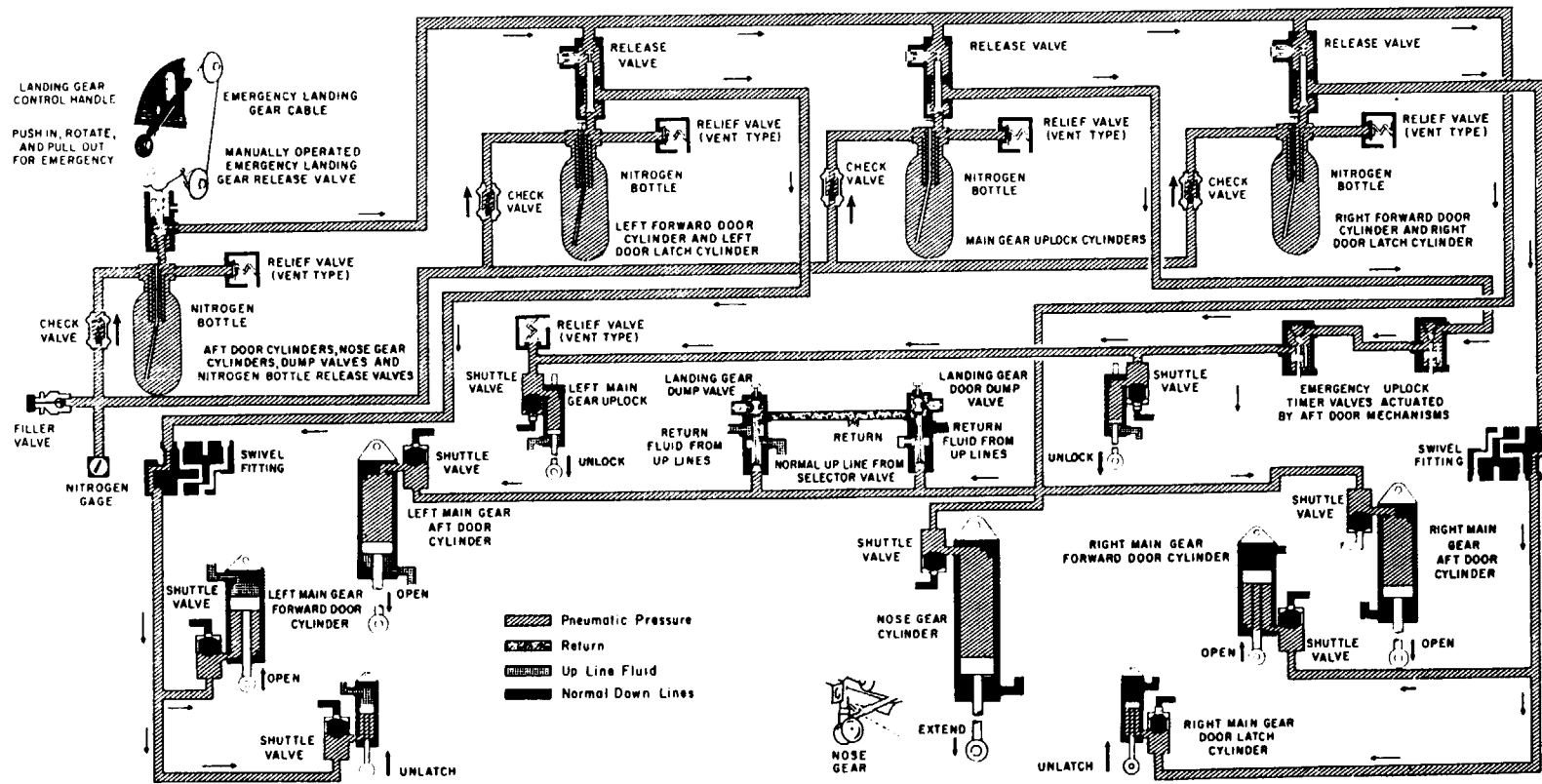

Figure 12-8.—Landing gear emergency extension system.

aft doors' cylinders and the shuttle valve on the nose gear cylinder to close off the normal port and operate these cylinders. The nose gear cylinder extends; this unlocks the uplock and extends the nose gear. The nitrogen flowing into the aft door cylinders opens the aft doors. Fluid on the close side of the door cylinder is vented to return through the actuated dump valves. Nitrogen from another bottle actuates the shuttle valves on the uplock cylinders. Nitrogen flows into the uplock cylinders and causes them to disengage the uplocks. As soon as the uplocks are disengaged, the main gear extends by the force of gravity. Fluid on the up side of the main gear cylinders is vented to return through the actuated dump valves, preventing a fluid lock.

JET BLAST DEFLECTORS

Jet blast deflectors (JBD) onboard aircraft carriers are raised and lowered by hydraulic cylinders through mechanical linkage. Two

hydraulic cylinders are attached to each JBD panel shaft by crank assemblies. (See fig. 12-9.) The shaft is rotated by the push and pull operation of the hydraulic cylinders. Shaft rotation extends or retracts the linkage to raise or lower the JBD panels. This operation is designed so that in the event of a failure of one of the hydraulic cylinders, the other one will raise or lower the panels.

Figure 12-10 is a diagram of the hydraulic control system of a JBD during the raise cycle. Hydraulic fluid from the catapult hydraulic supply system is supplied to the JBD hydraulic system through an isolation valve and a filter to the 4-way control valve assembly. (The 4-way control valve assembly consists of a pilot-operated control valve, a direct- or solenoid-operated control valve, and a sequence valve, which is not shown.)

To raise the JBD, solenoid B of the 4-way control valve assembly is energized. The spools of the 4-way valve assembly shift, allowing medium-pressure hydraulic fluid to flow into port A of the hydraulic cylinder. The cylinders extend,

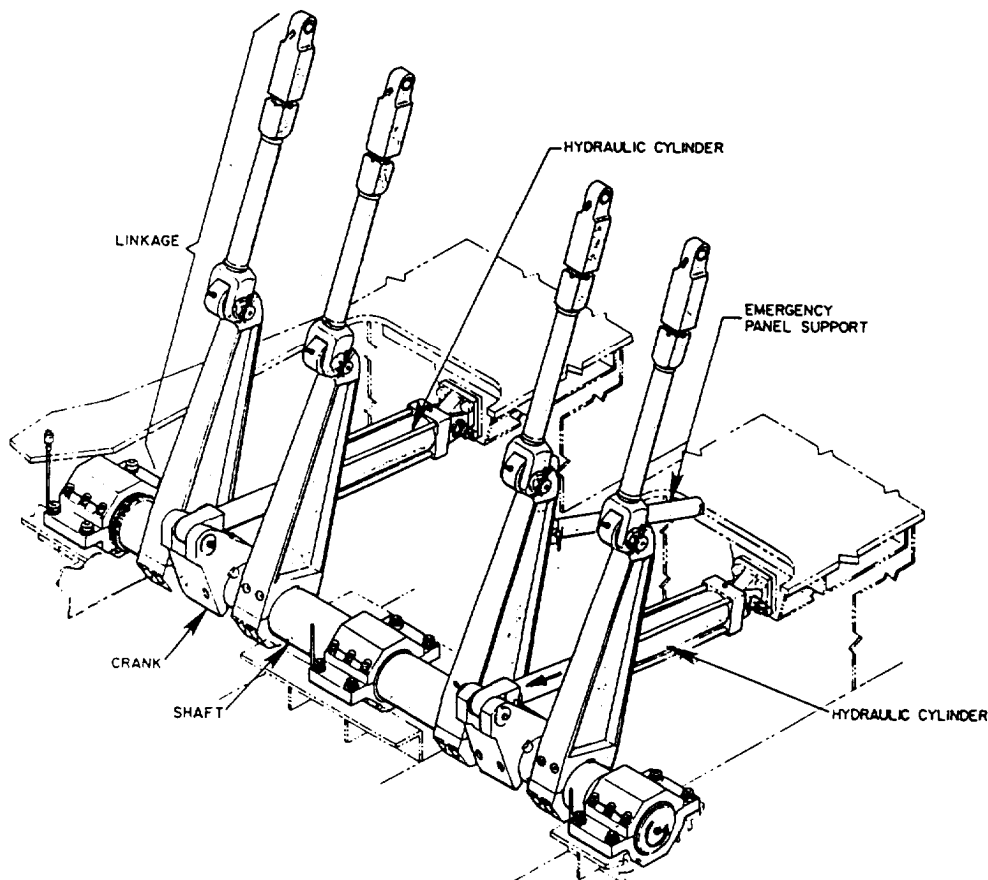

Figure 12-9.—Operating gear assembly (panels raised).

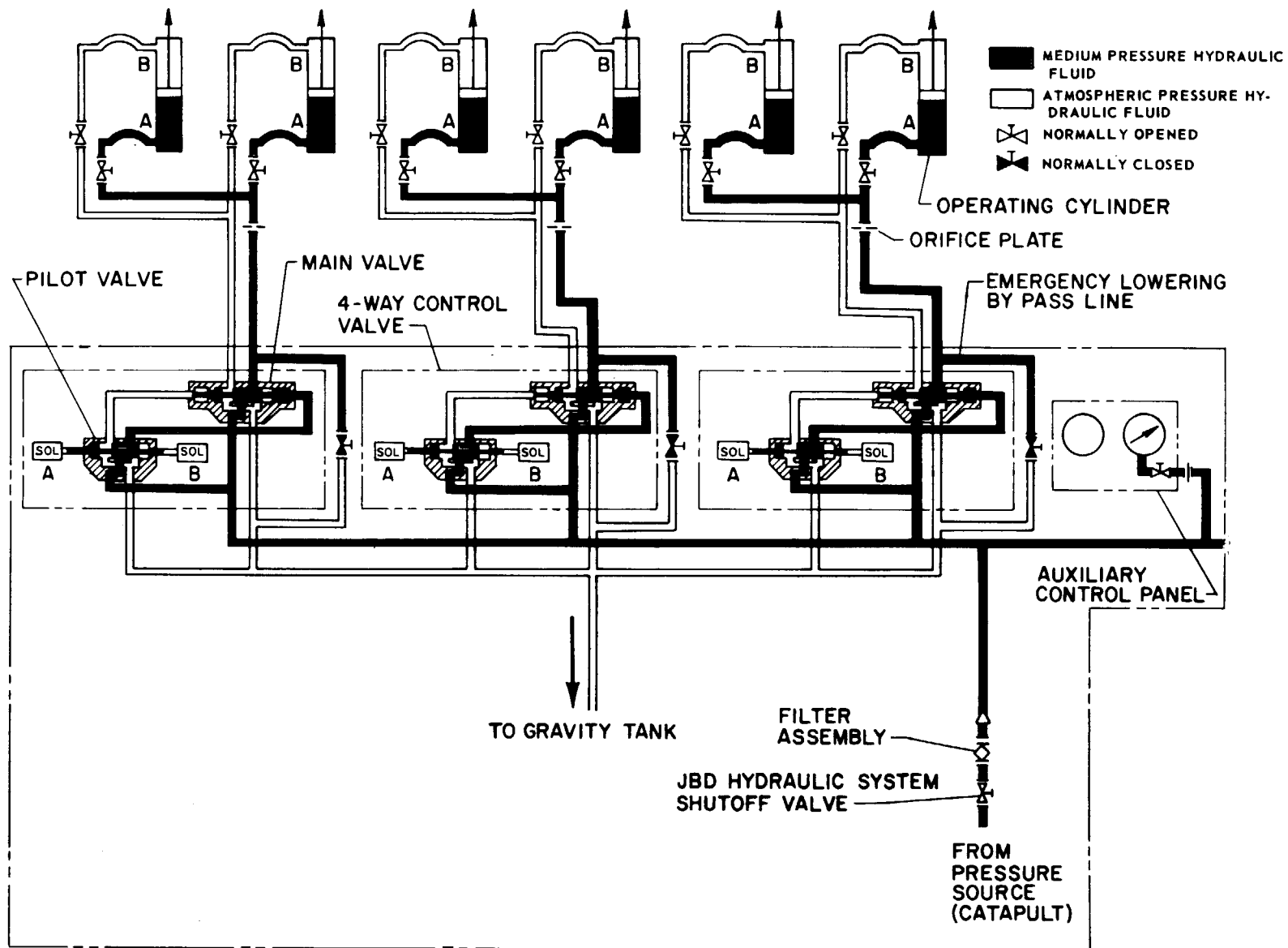

Figure 12-10.—Hydraulic system flow diagram, raise cycle.

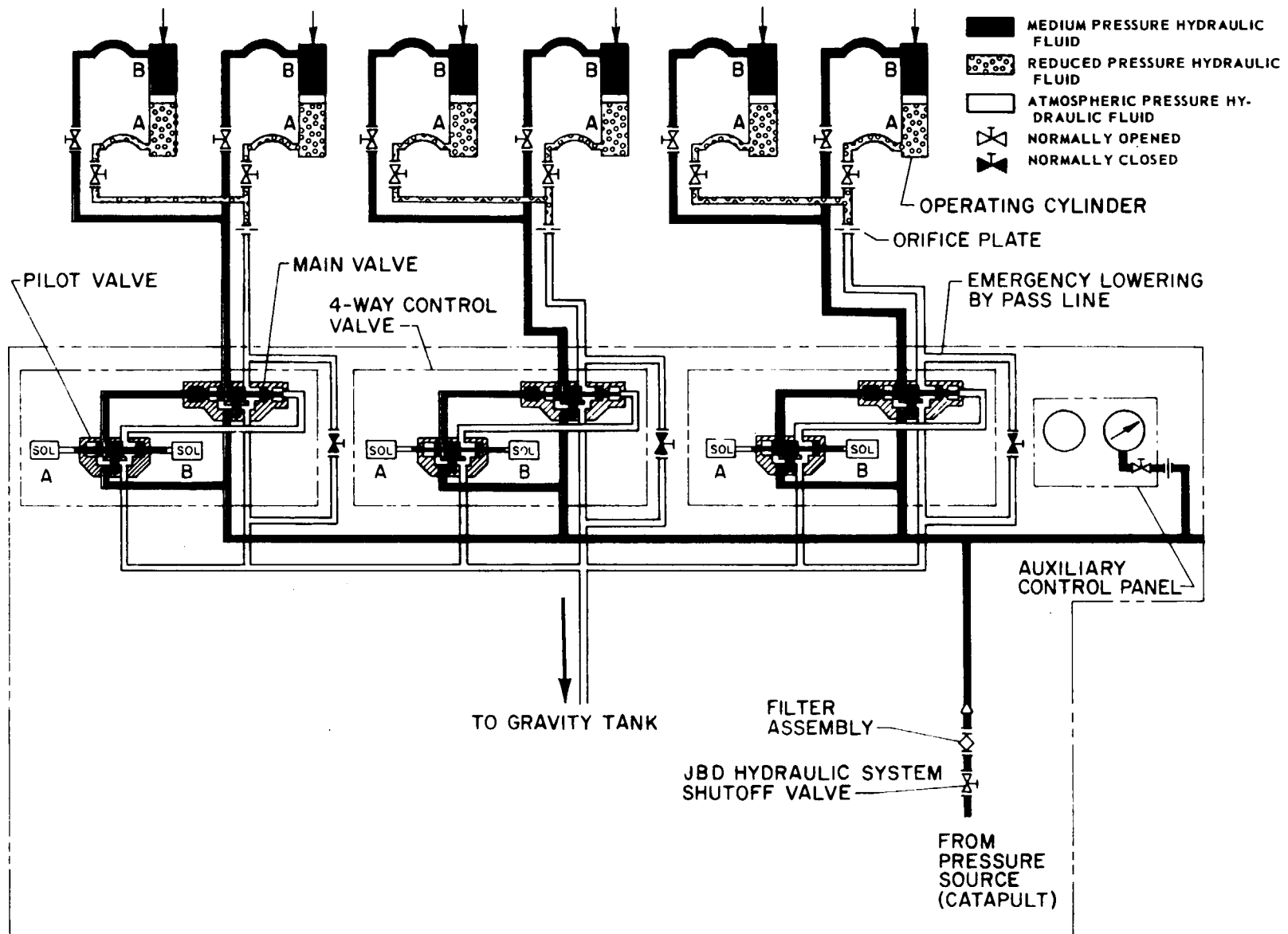

Figure 12-11.—Hydraulic system flow diagram, lower cycle.

pushing the crank assembly aft and rotating the shaft. The rotation of the shaft extends the operating gear linkage and raises the panel assemblies. Fluid from port B of the piston is directed through the 4-way valve assembly and back to the gravity tank.

To lower the JBD (fig. 12-11), solenoid A of the 4-way control valve assembly is energized. The spools of the 4-way valve assembly shift, allow medium-pressure hydraulic fluid to flow into port B of the hydraulic cylinder. The cylinders retract, pulling the crank assembly forward and rotating the shaft. The rotation of the shaft retracts the operating gear linkage and lowers the panel

assemblies. Fluid from port A of the piston is directed through the 4-way valve assembly and back to the gravity tank.

To lower the JBD in the event of hydraulic control failure, each JBD panel is equipped with a manual bypass valve, which allows bypassing the 4-way control valve. This allows venting the hydraulic pressure from the "raise" side of the cylinder back to the gravity tank.

The three lines to port A of the hydraulic cylinders have orifice assemblies in them. These orifice assemblies control the flow of hydraulic fluid in both the raise and lower operations.

APPENDIX I

GLOSSARY

A part of this glossary has been extracted from the *American Standard Glossary of Terms for Fluid Power* (ASA B93.2-1965) with permission of the publisher, The National Fluid Power Association.

ABSOLUTE TEMPERATURE—The temperature measured using absolute zero as a reference. Absolute zero is -273.16°C or -459.69°F .

ACCELERATION—Time rate of change of velocity.

ACCUMULATOR—A device for storing liquid under pressure. It usually consists of a chamber separated into a gas compartment and a liquid compartment by a piston or diaphragm. An accumulator also serves to smooth out pressure surges in a hydraulic system.

ACTUATOR—A device that converts fluid power into mechanical force and motion.

ADDITIVE—A chemical compound or compounds added to a fluid to change its properties.

AIR, COMPRESSED—Air at any pressure greater than atmospheric pressure.

AMBIENT—Surrounding, such as ambient air, meaning surrounding air.

BAROMETER—An instrument that measures atmospheric pressure.

BERNOULLI'S PRINCIPLE—If a fluid flowing through a tube reaches a constriction, or narrowing of the tube, the velocity of the fluid flowing through the constriction increases and the pressure decreases.

BLEEDER, AIR—A bleeder for the removal of air.

BOYLE'S LAW—The absolute pressure of a fixed mass of gas varies inversely as the volume, provided the temperature remains constant.

CAVITATION—A localized gaseous condition within a liquid stream that occurs where the pressure is reduced to the vapor pressure.

CELSIUS—The temperature scale using the freezing point of water as zero and the boiling point as 100, with 100 equal divisions between, called degrees. This scale was formerly known as the centigrade scale.

CENTIGRADE—(See Celsius.)

CENTRIFUGAL FORCE—A force exerted on a rotating object in a direction outward from the center of rotation.

CHARLES'S LAW—If the pressure is constant, the volume of dry gas varies directly with the absolute temperature.

CHEMICAL CHANGE—A change that alters the composition of the molecules of a substance.

CIRCUIT—An arrangement of interconnected component parts.

COMPRESSIBILITY—The change in volume of a unit volume of a fluid when it is subjected to a unit change of pressure.

COMPRESSOR—A device that converts mechanical force and motion into pneumatic fluid power.

COMPUTER—A device capable of accepting information, applying prescribed processes to the information, and supplying the results of these processes.

CONDENSATION—The change from a gaseous (or vapor) state to a liquid state.

CONTAMINANT—Detrimental matter in a fluid.

CONTINUITY EQUATION—The mass rate of fluid flow into any fixed space is equal to the mass flow rate out. Hence, the mass flow rate of fluid past all cross sections of a conduit is equal.

CONTROL—A device used to regulate the function of a component or system.

CONTROL, CYLINDER—A control in which a fluid cylinder is the actuating device.

CONTROL, ELECTRIC—A control actuated electrically.

CONTROL, HYDRAULIC—A control actuated by a liquid.

CONTROL, MANUAL—A control actuated by the operator.

CONTROL, MECHANICAL—A control actuated by linkages, gears, screws, cams, or other mechanical elements.

CONTROL, PNEUMATIC—A control actuated by air or other gas pressure.

CONTROL, SERVO—A control actuated by a feedback system that compares the output with the reference signal and makes corrections to reduce the difference.

CONTROLS, PUMP—Controls applied to positive-displacement variable delivery pumps to adjust their volumetric output or direction of flow.

CONVERGENT—That which inclines and approaches nearer together, as the inner walls of a tube that is constricted.

COOLER—A heat exchanger, which removes heat from a fluid.

COOLER, AFTERCOOLER—A device that cools a gas after it has been compressed.

COOLER, INTERCOOLER—A device that cools a gas between the compressive steps of a multiple stage compressor.

COOLER, PRECOOLER—A device that cools a gas before it is compressed.

CORROSION—The slow destruction of materials by chemical agents and electromechanical reactions.

CYCLE—A single complete operation consisting of progressive phases starting and ending at the neutral position.

CYLINDER—A device that converts fluid power into linear mechanical force and motion. It usually consists of a movable element, such as a piston and piston rod, plunger, or ram, operating within a cylindrical bore.

CYLINDER, CUSHIONED—A cylinder with a piston-assembly deceleration device at one of both ends of the stroke.

CYLINDER, DOUBLE-ACTING—A cylinder in which fluid force can be applied to the movable element in either direction.

CYLINDER, DOUBLE-ROD—A cylinder with a single piston and a piston rod extending from each end.

CYLINDER, DUAL-STROKE—A cylinder combination that provides two working strokes.

CYLINDER, PISTON—A cylinder in which the movable element has a greater cross-sectional area than the piston rod.

CYLINDER, PLUNGER—A cylinder in which the movable element has the same cross-sectional area as the piston rod.

CYLINDER, SINGLE-ACTING—A cylinder in which the fluid force can be applied to the movable element in only one direction.

CYLINDER, SINGLE-ROD—A cylinder with a piston rod extending from one end.

CYLINDER, SPRING-RETURN—A cylinder in which a spring returns the piston assembly.

CYLINDER, TANDEM—Two or more cylinders with interconnected piston assemblies.

CYLINDER, TELESCOPING—A cylinder with nested multiple tubular rod segments which provide a long working stroke in a short retracted envelope.

DENSITY—The weight per unit volume of a substance.

DIAGRAM, COMBINATION—A drawing using a combination of graphical, cutaway, and pictorial symbols.

DIAGRAM, CUTAWAY—A drawing showing principal internal parts of all components, controls, and actuating mechanisms, all interconnecting lines and functions of individual components.

DIAGRAM, GRAPHICAL—A drawing or drawings showing each piece of apparatus including all interconnecting lines by approved standard symbols.

DIAGRAM, PICTORIAL—A drawing showing each component in its actual shape according to the manufacturer's installation.

DIAGRAM, SCHEMATIC—(See Diagram, graphical.)

DIAPHRAGM—A dividing membrane or thin partition.

DIFFUSER—A duct of varying cross section designed to convert a high-speed gas flow into low-speed at an increased pressure.

DISPLACEMENT—The volume of fluid that can pass through a pump, motor, or cylinder in a single revolution or stroke.

DIVERGENT—Moving away from each other, as the inner wall of a tube that flares outward.

EFFICIENCY—The ratio of the output power to the input power, generally expressed as a percentage.

ENERGY—The ability or capacity to do work.

EQUILIBRIUM—A state of balance between opposing forces or actions.

FAHRENHEIT—The temperature scale using the freezing point of water as 32 and the boiling point as 212, with 180 equal divisions between, called degrees.

FEEDBACK—A transfer of energy from the output of a device to its input.

FILTER—A device whose primary function is the retention by a porous media of insoluble contaminants from a fluid.

FILTER ELEMENT—The porous device that performs the actual process of filtration.

FILTER MEDIA—The porous materials that perform the actual process of filtration.

FILTER MEDIA, SURFACE—Porous materials that primarily retain contaminants on the influent face.

FLASH POINT—The temperature to which a liquid must be heated under specified conditions of the test method to give off sufficient vapor to form a mixture with air that can be ignited momentarily by a specified flame.

FLOW, LAMINAR—A flow situation in which fluid moves in parallel layers (also referred to as streamline flow).

FLOW, METERED—Flow at a controlled rate.

FLOW, TURBULENT—A flow situation in which the fluid particles move in a random manner.

FLOW RATE—The volume, mass, or weight of a fluid passing through any conductor per unit of time.

FLOWMETER—An instrument used to measure quantity or the flow rate of a fluid motion.

FLUID—A liquid or a gas.

FLUID FLOW—The stream or movement of a fluid, or the rate of its movement.

FLUID FRICTION—Friction due to the viscosity of fluids.

FLUID, FIRE-RESISTANT—A fluid difficult to ignite, which shows little tendency to propagate flame.

FLUID, HYDRAULIC—A fluid suitable for use in a hydraulic system.

FLUID, PETROLEUM—A fluid composed of petroleum oil. It may contain additives.

FLUID, PHOSPHATE ESTER BASE—A fluid that contains a phosphate ester as one of the major components.

FLUID, SILICONE—A fluid composed of silicones. It may contain additives.

FLUID, WATER-GLYCOL—A fluid whose major constituents are water and one or more glycols or polyglycols.

FLUID STABILITY—Resistance of a fluid to permanent change in properties.

FLUID POWER—Energy transmitted and controlled through the use of fluids under pressure.

FLUID POWER SYSTEM—A system that transmits and controls power through use of a pressurized fluid within an enclosed circuit.

FOOT-POUND—The amount of work accomplished when a force of 1 pound produces a displacement of 1 foot.

FORCE—The action of one body on another tending to change the state of motion of the body acted upon.

FREE FLOW—Flow that encounters negligible resistance.

FRICTION—The action of one body or substance rubbing against another, such as fluid flowing against the walls of pipe; the resistance to motion caused by this rubbing.

FRICTION PRESSURE DROP—The decrease in the pressure of a fluid flowing through a passage attributable to the friction between the fluid and the passage walls.

GAS—The form of matter that has neither a definite shape nor a definite volume.

GASKET—A class of seals that provides a seal between two stationary parts.

GAUGE—An instrument or device for measuring, indicating, or comparing a physical characteristic.

GAUGE PRESSURE—Pressure above atmospheric pressure.

GAUGE SNUBBER—A device installed in the line to the pressure gauge used to dampen pressure surges and thus provide a steady reading and a protection for the gauge.

GAUGE, BELLOWS—A gauge in which the sensing element is a convoluted closed cylinder. A pressure differential between the outside and the inside causes the cylinder to expand or contract axially.

GAUGE, BOURDON TUBE—A pressure gauge in which the sensing element is a curved tube that tends to straighten out when subjected to internal fluid pressure.

GAUGE, DIAPHRAGM—A gauge in which the sensing element is relatively thin and its inner portion is free to deflect with respect to its periphery.

GAUGE, PRESSURE—A gauge that indicates the pressure in the system to which it is connected.

GAUGE, VACUUM—A pressure gauge for pressures less than atmospheric.

GRAVITY—The force that tends to draw all bodies toward the center of the earth. The weight of a body is the resultant of gravitational force acting on the body.

HEAD—The height of a column or body of fluid above a given point expressed in linear units. Head is often used to indicate gauge pressure. Pressure is equal to the height times the density of the fluid.

HEAD, FRICTION—The head required to overcome the friction at the interior surface of a conductor and between fluid particles in motion. It varies with flow, size, type, and condition of conductors and fittings, and fluid characteristics,

HEAD, STATIC—The height of a column or body of fluid above a given point.

HEAD, VELOCITY—The equivalent head through which the liquid would have to fall to attain a given velocity. Mathematically it is equal to the square of the velocity (in feet) divided by 64.4 feet per second square.

HEAT EXCHANGER—A device that transfers heat through a conducting wall from one fluid to another.

HYDRAULICS—Engineering science pertaining to liquid pressure and flow.

HYDROMETER—An instrument for determining the specific gravities of liquids.

HYDROPNEUMATICS—Pertaining to the combination of hydraulic and pneumatic fluid power.

HYDROSTATICS—Engineering science pertaining to the energy of liquids at rest.

IMPACT PRESSURE—The pressure of a moving fluid brought to rest that is in excess of the pressure the fluid has when it does not flow; that is, total pressure less static pressure. Impact pressure is equal to dynamic pressure in incompressible flow; but in compressible flow, impact pressure includes the pressure change owing to the compressibility effect.

IMPINGEMENT—The striking or dashing upon with a clash or sharp collision, as air impinging upon the rotor of a turbine or motor.

IMPULSE TURBINE—A turbine driven by a fluid at high velocity under relatively low pressure.

INERTIA—The tendency of a body at rest to remain at rest, and a body in motion to continue to move at a constant speed along a straight line, unless the body is acted upon in either case by an unbalanced force.

INHIBITOR—Any substance which slows or prevents chemical reactions such as corrosion or oxidation.

INVERSE PROPORTION—The relation that exists between two quantities when an increase in one of them produces a corresponding decrease in the other.

KELVIN SCALE—The temperature scale using absolute zero as the zero point and divisions that are the same size as centigrade degrees.

KINETIC ENERGY—The energy that a substance has while it is in motion.

KINETIC THEORY—A theory of matter that assumes that the molecules of matter are in constant motion.

LINE—A tube, pipe, or hose that is used as a conductor of fluid.

LIQUID—A form of matter that has a definite volume but takes the shape of its container.

LOAD—The power that is being delivered by any power-producing device. The equipment that uses the power from the power-producing device.

LUBRICATOR—A device that adds controlled or metered amounts of lubricant into a fluid power system.

MANIFOLD—A type of fluid conductor that provides multiple connections ports.

MANOMETER—A differential pressure gauge in which pressure is indicated by the height of a liquid column of known density. Pressure is equal to the difference in vertical height between two connected columns multiplied by the density of the manometer liquid. Some forms of manometers are U tube, inclined tube, well, and bell types.

MATTER—Any substance that occupies space and has weight.

MECHANICAL ADVANTAGE—The ratio of the resisting weight to the acting force. The ratio of the distance through which the force is exerted divided by the distance the weight is raised.

METER-IN—To regulate the amount of fluid into a system or an actuator.

METER-OUT—To regulate the flow of fluid from a system or actuator.

MICRON—A millionth of a meter or about 0.00004 inch.

MOLECULE—A small natural particle of matter composed of two or more atoms.

MOTOR—A device that converts fluid power into mechanical force and motion. It usually provides rotary mechanical motion.

MOTOR, FIXED-DISPLACEMENT—A motor in which the displacement per unit of output motion cannot be varied.

MOTOR, LINEAR—(See Cylinder.)

MOTOR, ROTARY—A motor capable of continuous rotary motion.

MOTOR, ROTARY LIMITED—A rotary motor having limited motion.

MOTOR, VARIABLE-DISPLACEMENT—A motor in which the displacement per unit of output motion can be varied.

NEOPRENE—A synthetic rubber highly resistant to oil, light, heat, and oxidation.

NEUTRALIZATION NUMBER—A measure of the total acidity or basicity of an oil; this includes organic or inorganic acids or bases or a combination of them.

OXIDATION—The process by which oxygen unites with some other substance, causing rust or corrosion.

PACKING—A class of seal that is used to provide a seal between two parts of a unit which move in relation to each other.

PASCAL'S LAW—A pressure applied to a confined fluid at rest is transmitted with equal intensity throughout the fluid.

PERIPHERY—The outside surface, especially that of a rounded object or body.

PIPE—A type of fluid line whose dimensions are designated by nominal (approximate) inside diameter and wall thickness.

PNEUMATICS—Engineering science pertaining to gaseous pressure and flow.

PORT—An internal or external terminus of a passage in a component.

POTENTIAL ENERGY—The energy a substance has because of its position, its condition, or its chemical composition.

POUR POINT—The lowest temperature at which a liquid will flow under specified conditions.

POWER UNIT—A combination of pump, pump drive, reservoir, controls, and conditioning components which may be required for its application.

POWER—The rate of doing work or the rate of expanding energy.

PRESSURE—The amount of force distributed over each unit of area, usually expressed in pounds per square inch.

PRESSURE, ABSOLUTE—The sum of atmospheric and gauge pressures.

PRESSURE, ATMOSPHERIC—Pressure exerted by the atmosphere at any specific location.

PRESSURE, BACK—The pressure encountered on the return side of a system.

PRESSURE, DIFFERENTIAL—The difference in pressure between any two points of a system or a component.

PRESSURE, HEAD—The pressure due to the height of a column or body of fluid. It is usually expressed in feet.

PRESSURE, OPERATING—The pressure at which a system operates.

PRESSURE, PRECHARGE—The pressure of compressed gas in an accumulator prior to the admission of a liquid.

PRESSURE, PROOF—The nondestructive test pressure in excess of the maximum rated operating pressure.

PRESSURE, STATIC—The pressure in a fluid at rest.

PRESSURE SWITCH—An electrical switch operated by the increase or decrease of fluid pressure.

PRIME MOVER—The source of mechanical power used to drive the pump or compressor.

PUMP—A device that converts mechanical force and motion into hydraulic fluid power.

PUMP, AXIAL PISTON—A pump having multiple pistons disposed with their axes parallel.

PUMP, CENTRIFUGAL—A pump that produces fluid velocity and converts it to pressure head.

PUMP, FIXED-DISPLACEMENT—A pump in which the displacement per cycle cannot be varied.

PUMP, RADIAL PISTON—A pump having multiple pistons disposed radially actuated by an eccentric element.

PUMP, VARIABLE-DISPLACEMENT—A pump in which the volume of fluid per cycle can be varied.

RANKINE SCALE—A thermometer scale based on absolute zero of the Fahrenheit scale, in which the freezing point of water is approximately 492°R.

RATIO—The value obtained by dividing one number by another, indicating their relative proportions.

RECEIVER—A container in which gas is stored under pressure as a supply source for pneumatic power.

RECIPROCATING—Moving back and forth, as a piston reciprocating in a cylinder.

RESERVOIR—A container for storage of liquid in a fluid power system.

RESPONSE TIME—The time lag between a signal input and the resulting change of output.

RESTRICTOR—A device that reduces the cross-sectional flow area.

RESTRICTOR, ORIFICE—A restrictor, the length of which is relatively small with respect to its cross-sectional area. The orifice may be fixed or variable. Variable types are noncompensated, pressure compensated, or pressure and temperature compensated.

RETURN LINE—A line used for returning fluid back into the reservoir or atmosphere.

SEPARATOR—A device whose primary function is to isolate undesirable fluids and or contaminants by physical properties other than size.

SERVO—A device used to convert a small movement into a greater movement of force.

SOLID—The form of matter that has a definite shape and a definite volume.

SPECIFIC GRAVITY—The ratio of the weight of a given volume of a substance to the weight of an equal volume of some standard substance.

STEADY FLOW—A flow in which the velocity, pressure, and temperature at any point in the fluid do not vary with time.

STRAINER—A coarse filter.

STOKE—The standard unit of kinematic viscosity in the cgs system. It is expressed in square centimeters per second; 1 centistoke equals 0.01 stoke.

STUFFING BOX—A cavity and closure with manual adjustment for a sealing device.

SUPPLY LINE—A line that conveys fluid from the reservoir to the pump.

SURGE—A momentary rise of pressure in a circuit.

SYNCHRONIZE—To make two or more events or operations occur at the proper time with respect to each other.

SYNTHETIC MATERIAL—A complex chemical compound that is artificially formed by the combining of two or more simpler compounds or elements.

TANK—A container for the storage of fluid in a fluid power system.

THEORY—A scientific explanation, tested by observations and experiments.

THERMAL EXPANSION—The increase in volume of a substance due to temperature change.

TORQUE—A force or combination of forces that produces or tends to produce a twisting or rotary motion.

TUBING—A type of fluid line whose dimensions are designated by actual measured outside diameter and by actual measured wall thickness.

TURBINE—A rotary motor actuated by the reaction, impulse, or both, of a flow of pressurized fluid.

VALVE—A device that controls fluid flow direction, pressure, or flow rate.

VALVE, CHECK—A directional control valve that permits flow of fluid in only one direction.

VALVE, COUNTERBALANCE—A pressure control valve that maintains back pressure to prevent a load from falling.

VALVE, DIRECTIONAL CONTROL—A valve whose primary function is to direct or prevent flow through selected passages.

VALVE, FLOW CONTROL—A valve whose primary function is to control flow rate.

VALVE, HYDRAULIC—A valve for controlling liquid.

VALVE, PILOT—A valve used to operate another valve or control.

VALVE, PNEUMATIC—A valve for controlling gas.

VALVE, PRESSURE REDUCING—A pressure control valve whose primary function is to limit outlet pressure.

VALVE, PRIORITY—A valve that directs flow to one operating circuit at a fixed rate and directs excess flow to another operating circuit.

VALVE, RELIEF—A pressure control valve whose primary function is to limit system pressure.

VALVE, SELECTOR—A directional control valve whose primary function is to selectively interconnect two or more ports.

VALVE, SEQUENCE—A valve whose primary function is to direct flow in a predetermined sequence.

VALVE, SERVO—A directional control valve that modulates flow or pressure as a function of its input signal.

VALVE, SHUTOFF—A valve that operates fully open or fully closed.

VALVE, UNLOADING—A pressure control valve whose primary function is to permit a pump or compressor to operate at minimum load.

VELOCITY—The rate of motion in a particular direction. The velocity of fluids is usually expressed in feet per second.

VENTURI—A tube having a narrowing throat or constriction to increase the velocity of fluid flowing through it. The flow through the venturi causes a pressure drop in the smallest section, the amount being a function of the velocity of flow.

VISCOSITY—A measure of the internal friction or resistance of a fluid to flow.

VISCOSITY INDEX—A measure of the viscosity-temperature characteristics of a fluid as referred to that of two arbitrary reference fluids.

VISCOSITY, SAYBOLT UNIVERSAL SECONDS (SUS)—The time in seconds for 60 milliliters of oil to flow through a standard orifice at a given temperature.

VISCOSITY, KINEMATIC—The absolute viscosity divided by the density of the fluid. It is usually expressed in centistokes.

VOLUME OF FLOW—The quantity of fluid that passes a certain point in a unit of time. The volume of flow is usually expressed in gallons per minute for liquids and cubic feet per minute for gases.

WORK—The transference of energy from one body or system to another. That which is accomplished by a force acting through a distance.

APPENDIX II

MECHANICAL SYMBOLS OTHER THAN AERONAUTICAL FOR FLUID POWER DIAGRAMS

LINES

LINES, WORKING



LINES, PILOT



LINES, LIQUID DRAIN OR AIR EXHAUST



LINES, CROSSING

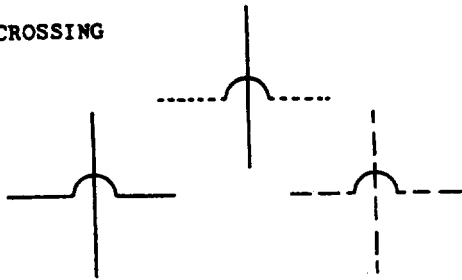

LINES, JOINING

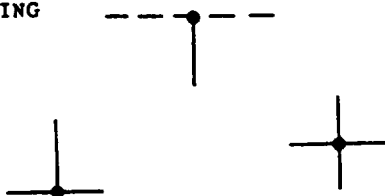

LINES, FLEXIBLE



FLOW, DIRECTION OF

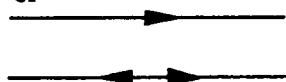

LINES TO RESERVOIR
BELOW FLUID LEVEL



ABOVE FLUID
LEVEL



PLUG OR PLUGGED CONNECTION



TESTING STATION

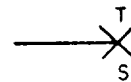

FLUID POWER TAKE-OFF
STATION

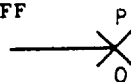

RESTRICTION, FIXED



QUICK DISCONNECT
WITHOUT CHECKS

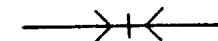

WITH CHECKS
DISCONNECTED

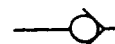

WITH ONE CHECK

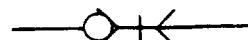

WITH TWO CHECKS

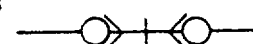

PUMPS, COMPRESSORS & ROTARY MOTORS

BASIC SYMBOL
ENVELOPE



COMPRESSORS, AIR

PORTS

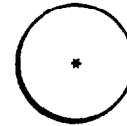
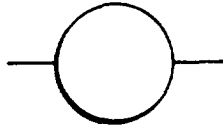

LINES OUTSIDE ENVELOPE ARE NOT PART OF SYMBOL, BUT REPRESENT FLOW LINES CONNECTED THERETO.

APPROPRIATE SYMBOLS SHALL BE ADDED TO INDICATE SHAFTS, CONNECTING LINES, AND METHOD OF CONTROL.

* TYPE OF COMPRESSOR SHALL BE INDICATED WITHIN BASIC SYMBOL BY APPROPRIATE LETTERS LISTED BELOW.

SHAFTS, ROTATING

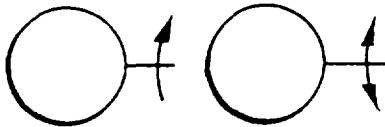

CF FIXED DISPLACEMENT
CK KINETIC

ARROW INDICATES DIRECTION OF ROTATION BY ASSUMING IT IS ON NEAR SIDE OF SHAFT.

FLUID MOTORS, ROTARY

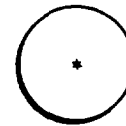

PUMPS, HYDRAULIC

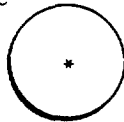

APPROPRIATE SYMBOLS SHALL BE ADDED TO INDICATE SHAFTS, CONNECTING LINES, AND METHOD OF CONTROL.

* TYPE OF PUMP SHALL BE INDICATED WITHIN BASIC SYMBOL BY APPROPRIATE LETTERS LISTED BELOW.

APPROPRIATE SYMBOLS SHALL BE ADDED TO INDICATE SHAFTS, CONNECTING LINES, AND METHOD OF CONTROL.

* TYPE OF MOTOR SHALL BE INDICATED WITHIN BASIC SYMBOL BY APPROPRIATE LETTERS LISTED BELOW.

PF FIXED DISPLACEMENT
PK KINETIC - CENTRIFUGAL
PV VARIABLE DISPLACEMENT

MF FIXED DISPLACEMENT
MO OSCILLATING
MV VARIABLE DISPLACEMENT

CYLINDERS

SINGLE ACTING

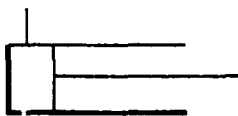

DOUBLE ACTING
SINGLE END ROD

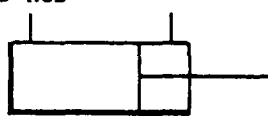

DOUBLE END ROD

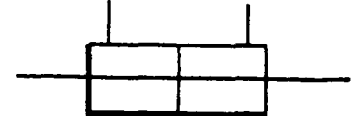

RESERVOIRS

VENTED







PRESSURIZED











RECEIVER FOR AIR OR OTHER GASES









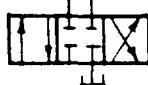







VALVE

VALVE, CHECK	
VALVE, RESTRICTION, CHOKE VARIABLE VISCOUS	
VALVE, RESTRICTION, ORIFICE VARIABLE NON-VISCOUS	
VALVE, BASIC SYMBOL (INSERT MODEL NO. FOR SPECIAL VALVES)	
METHOD OF INDICATING INTERNAL FLOW	

VALVE EXAMPLES

VALVE, MANUAL SHUT OFF	
VALVE, RELIEF MAXIMUM PRESSURE	
VALVE, RELIEF REMOTELY OPERATED	
VALVE, SEQUENCE DIRECTLY OPERATED	
VALVE, PRESSURE REDUCING	
VALVE, SHUT OFF 2 POSITION-2 CONNECTION	
VALVE, DIRECTIONAL 2 POSITION-3 CONNECTION	
VALVE, DIRECTIONAL 2 POSITION-4 CONNECTION	
VALVE, DIRECTIONAL 3 POSITION-4 CONNECTION OPEN CENTER	
VALVE, DIRECTIONAL 3 POSITION-4 CONNECTION CLOSED CENTER	

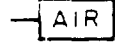
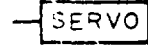
TYPE OF CONTROL

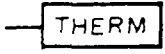
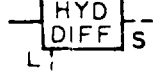
CONTROL, BASIC SYMBOL	
CONTROL, CENTRIFUGAL	
CONTROL, COMPENSATOR	
CONTROL, COMPENSATOR PRESSURE	
CONTROL, COMPENSATOR TEMPERATURE	
CONTROL, CYLINDER	
CONTROL, DETENT	
CONTROL, MANUAL	
CONTROL, MECHANICAL	
CONTROL, MOTOR ELECTRIC	
CONTROL, MOTOR HYDRAULIC	
CONTROL, PILOT HYDRAULIC	
CONTROL, PILOT AIR	
CONTROL, SERVO	
CONTROL, SOLENOID	
CONTROL, SOLENOID HYD. PILOT OPERATED	
CONTROL, THERMAL	
CONTROL, PILOT HYD. DIFFERENTIAL AREA	

MISCELLANEOUS UNITS

MOTOR, ELECTRIC



STRAINER



HEAT EXCHANGER



PRESSURE SWITCH



INTENSIFIER



PRESSURE GAGE



ACCUMULATOR



SPRING



FILTER



COMPONENT ENCLOSURE

