



PDHonline Course M428 (4 PDH)

Heat Tracing Systems

Instructor: A. Bhatia, B.E.

2020

PDH Online | PDH Center

5272 Meadow Estates Drive
Fairfax, VA 22030-6658
Phone: 703-988-0088
www.PDHonline.com

An Approved Continuing Education Provider

HEAT TRACING SYSTEMS

A. Bhatia, B.E.

Abstract

The term heat-tracing refers to the continuous or intermittent application of heat on the piping, equipment, and instrumentation where fluid (water or other product) may be exposed to low temperature/freezing conditions. Whenever the contents of a pipe or vessel are maintained at temperatures exceeding the ambient temperature, there will be a flow of heat from the product to the external air. Insulation will slow the heat loss, but will not prevent it. Heat tracing is a method to provide the supplemental heat just enough to compensate for the heat loss due to lower ambient temperature.

The general intent of heat tracing is either tracing for winterization and/or tracing for process maintenance. Winterization tracing is designed to protect the product from freezing and is typically designed to operate when the ambient temperature falls below a certain level — commonly 40°F to 50°F. Heat tracing for process maintenance is commonly used where higher temperatures must be maintained for the purpose of reducing product viscosity and/or preventing wax or hydrates from forming in the product. The design is more complex compared to freeze protection in a way that additional heater circuits and more specialized controls may be needed.

Sometimes, heat tracing is used for raising the temperature of product following short shutdown periods, but this is not a primary objective.

Types of Heat Tracing Systems

Heat tracing can be accomplished through several methods, including electricity, steam, glycol, and even hot oil. However for the majority of applications, the choice falls between electric and steam tracing.

Electrical heat tracing is a system incorporating electrical heating cables attached to the product pipe or the equipment surface. The majority of commercial electric heat-tracing systems use the resistive type heater, wherein the heat is produced in proportion to the square of the current (I) and the resistance (R) of the elements (I^2R). Other

specialized electric tracing systems make use of impedance, induction, and skin conduction effects to generate and transfer heat.

Steam tracing is described by attaching a carbon steel, copper or stainless steel tubing containing low pressure saturated steam to the product pipe. The two pipes are then insulated together and jacketed, if necessary. The tracer tube size varies from ¼ - ½” diameter for winterization or instrumentation tracing, and 3/8” to 1” diameter for process pipe tracing. The other available options are 1) the use of cemented steam tracing, which uses conductive cement cased over steam tracer tubes and 2) the use of jacketed pipe when extremely high heat flow is required. In all these approaches, the condensate produced is removed at strategic locations using energy efficient steam traps and is returned back to the boiler (steam generator).

Electric or Steam Heat Tracing!

The most significant factor in deciding steam or electric tracing is the initial investment on equipment, installation and the operating costs. These costs depend on factors such as availability and reliability of energy supplies, cost of labor and local tracing practice. In general:

Steam tracing is frequently chosen in plants where steam is easily available as a by-product of condensation (“flash” steam) or where generated from waste heat or where surplus capacity exist that must be either used or lost. The incentive to use steam in such scenarios will be compelling. It is doubtful that anyone would invest in a steam boiler and associated infrastructure for heat tracing only. The other pros and cons are discussed later in Section-4 of the course.

Electric tracing offers convenience of installation and provides better temperature control and much more efficient utilization of energy. Auxiliary equipment is not required, so the total operating costs include only the electrical usage for the electric heat tracing and the control system. However, the reliability of the power for uninterrupted delivery, available voltages, and the consequences of outages must be evaluated when considering its use.

This course presents an overview of heat tracing systems and describes the criteria for selection. The course is divided into 4 sections:

- SECTION – 1: Overview of Electric Heat Tracing
- SECTION – 2: Overview of Steam Heat Tracing
- SECTION - 3: Estimating Heat Tracing Requirements
- SECTION – 4: Selection Criteria for Heat Tracing Systems

SECTION – 1: OVERVIEW OF ELECTRIC HEAT-TRACING

Electric trace heating (also known as electric heat tape) takes the form of an electrical heating element run in physical contact along the length of a pipe. Heat generated by the element will maintain the temperature of the pipe and the wrapped thermal insulation retains the heat losses from the pipe.

TYPES OF ELECTRIC HEAT TRACING SYSTEMS

Electric trace heating cable can be divided into four distinct product classifications:

1. Series circuit, Mineral insulated (MI) cables (constant watt output)
2. Parallel circuit heating cables (constant watt output)
3. Self-regulating heating cables (variable watt output)
4. Skin effect heating

SERIES CIRCUIT MINERAL INSULATED (MI) CABLES

Series resistance-type heater cables use single or multiple resistive conductors to create a heating circuit. Power output of these cables is relatively constant and as voltage is applied, the power output is determined by a combination of the length of the cable and the overall resistance of the conductor. The drawback is that since the power output is dependent on the length of the cable, these cables are always supplied in predetermined factory-terminated lengths. If the cable is cut too short or too long, the overall resistance will change, resulting in a cable that provides either too little or too much heat output. Another serious drawback is that a break anywhere along the line will result in complete failure of the tracing.

Series resistance cables are available with flexible, polymer outer-jackets as well as with a metal jacket commonly known as mineral insulated (MI) cable. A mineral Insulated (MI) cable essentially consists of one or two conductors of copper or alloy embedded in dielectric magnesium oxide insulation and surrounded by an Incoloy 825 sheath. These cables are recognized for their high temperature service and excellent protection against corrosion. Circuit below indicates MI cable with two conductors in series arrangement.

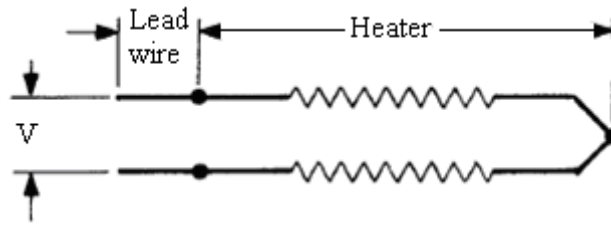

Features:

- Power output of these cables is relatively constant, and they do not exhibit self-regulating characteristics;
- Suitable for high temperature and harsh environments;
- Voltage up to 600VAC;
- Wattage output up to 80 W/ft;
- Long circuit lengths (up to 4000 ft.);
- Uniform power along the entire length;
- Copper construction: Maintain up to 300°F, Exposure up to 482°F;
- Alloy construction: Maintain up to 1500°F, Exposure up to 1750°F;
- Series circuit heaters are most commonly used in a 3 phase configuration for heating of long pipelines;
- No start-up current.

Advantages

- Extremely long circuit lengths are possible;
- Can have very high watt output which can be used in some process heating applications (as high as 1500°F for MI cable);
- Relatively low cost per feet length.

Limitations

- Available in standard lengths; field adjustments are difficult and costly;
- A single break in the cable causes the entire system to fail;

- Cannot be used on plastic pipe;
- Cannot be overlapped – will burn out from excessive heat;
- Relatively inflexible – difficult to install;
- Caution must be exercised for installing these cables in a hazardous area, as these cables do not self-regulate — and may have exceedingly high sheath temperatures during operation.

PARALLEL CIRCUIT HEATING CABLES (CONSTANT WATT OUTPUT)

Parallel circuit cables are constant watt arrangement designed to put out a certain amount of wattage per linear foot of cable. These are generally constructed of two #12AWG polymer insulated parallel bus wires with a nickel alloy heating element wire wrapped alternatively along the insulated bus wires. These connections are made at the 'NODE' point where the nickel- alloy heating element is either welded or connected by rivets. The entire element assembly is then dielectrically insulated with an additional polymer jacket.

The parallel resistor arrangement has two distinct advantages:

1. The power output per unit length is constant, regardless of the overall length of the heating unit;
2. The parallel arrangement preserves systems integrity i.e. if any section of cable should fail, the rest of the heater will continue to operate. This is an important advantage over series circuits.

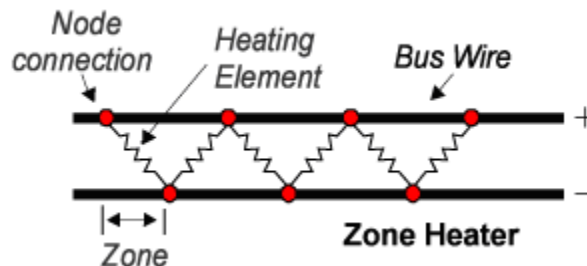

The output ratings of these cables depend on the resistance of nickel alloy wire and the amount used between node connections. Consequently, manufacturers standardize the output wattages to specified values. These cables can be cut to any convenient length in

field within the limits imposed by the maximum heating circuit length (typically 160 to 320 ft) and minimum bus- bar connection interval. When terminated the last 2-foot heater section becomes a “cold section”. This provides an unheated section of cable to penetrate the insulation, enter the junction box and make up power connections.

Features:

- Parallel circuit construction;
- Standard 120V, 240V and 480V operation;
- Maintain up to 500°F, Exposure to 650°F;
- Output limited to 16 W/ft;
- Cut-to-length in field, simplifies installation;
- No start-up current.

Advantages

- The constant wattage output makes maintaining higher and more accurate process temperatures easier.
- Operates on standard voltages and easily controlled;
- System continues to operate even if any element fails;
- Available in wide variety of wattage outputs and design temperatures up to 500°F;
- Ideally suited for applications where a particular watt density is required at all times such as freeze protection and many other low temperature process control applications.

Limitations

- Excess heat output may overheat pipe contents; if not controlled, these are susceptible to burnout;
- Cannot be used on plastic pipes;
- Lower temperature limits than MI cable;

- Zone heaters use thinner resistive wires than series heaters and are more susceptible to damage from impact;
- Spiraling of cable around the pipe work should be avoided to minimize the possibility of induced currents in the pipe work.

SELF-REGULATING HEATING CABLE

Self-regulating heating cables are the latest advance in electric cable products. They are designed and built to regulate their output per the process needs i.e. as the process temperature drops, the cable's output increases; conversely, as the temperature rises, the cable's output decreases.

Self regulating heating cable consists of a polymer core extruded onto two parallel conductors. The core contains semi-conductive material that is high in carbon content usually "graphite", which allows electricity to flow from one bus wire to the other and create infinitely parallel resistors. The core's resistance changes proportionally with temperature and the output varies along the length of the cable depending upon the temperature of the core of the heater.

The principle of operation is that "when the temperature of the core increases or decreases, a change in the chemical composition takes place, which results in a higher or lower resistance and more or less heat output". This self-regulating characteristic allows the cable to adjust its watt output at any point along the entire length of the heater circuit, helping to eliminate hot or cold spots.

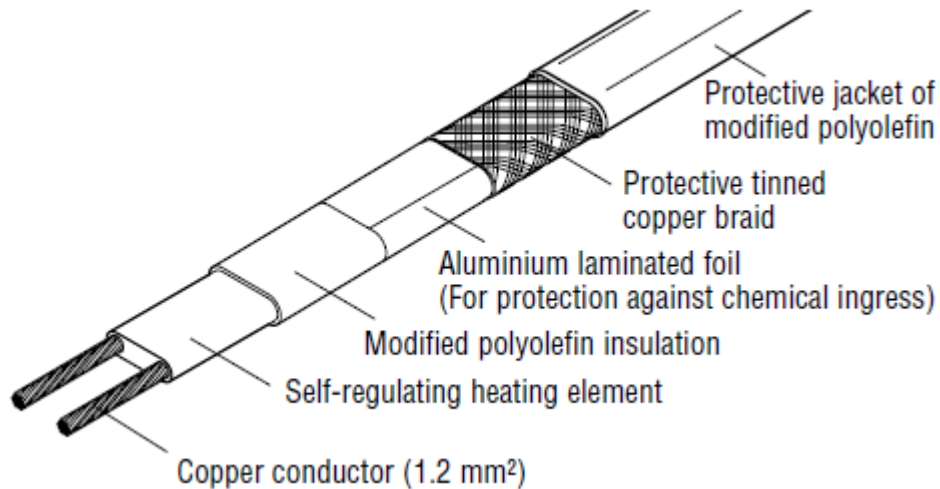

The key to understanding self-regulating cable is that its output adjusts proportionally to the cable sheath temperature and NOT the temperature of the pipe heated. This temperature response occurs independently at each point along the heater. Since power output is a function of temperature at any location in the element, the conductive core behaves as a temperature-sensitive rheostat guarding against low- as well as high temperature. Therefore, no separate control device is needed in principle; however, if a specific temperature is required or to be maintained, then some sort of control device must be used.

Features:

- Parallel circuit construction;
- These cables may be cut to any length without changing the overall resistance of the cable;
- Adjust the power output i.e. increases power as temperature falls and decreases as temperature rises;
- Standard 120V and 240V operation;
- Maximum circuit lengths are typically 150 to 600 ft;
- Available in wide variety of wattages generally ranging from a low of about 3 watts/foot up to 20 watts/foot at 50°F pipe temperature;

- Maintain up to 250°F, exposure up to 375°F;

Advantages

- Variable output, less chance of overheating;
- Maintains uniform temperature profile throughout the pipeline which results in greater energy economy;
- Intrinsically safe and can be used in hazardous areas. In fact, it has been given an unconditional T-rating* (see section -4 under “Area Classification”);
- Cut-to-length in field, easy installation;
- The tracer once installed, generally do not require any replacement for the entire life of the plant. The self regulating type tracers are usually guaranteed for more than 40 years of working life;
- Flexible and can be overlapped without burnout;
- Works well for freeze protection and low temperature applications that do not require very tight control;
- Low temperature cable can be used in a wide range of applications, including applications involving nonmetallic piping and equipment.

Limitations

- Have shorter circuit lengths than constant wattage MI cable;
- Most self-regulating cables are designed to give their rated wattage at 50°F. The wattage output will exceed the rated wattage when the cable temperature is below 50 degrees and the lower the cable temperature the larger this wattage i.e. amperage is “inrush” (a high start up current is the result). Circuit breakers of sufficient capacity to allow for the inrush current of initial start-up must be installed for protection against over-current;
- Precision tight temperature control is also more difficult with self-regulating cable, because the wattage output is always changing seeking 50°F on the cable not

the pipe or fluid in the pipe. Since there is no direct feed back for the pipe temperature, these cables are not well suited for process control;

- Cannot be used on 480V;
- Low design temperatures.

SKIN EFFECT HEAT TRACING

In Skin-effect Tracing System (STS), heat is generated on the inner surface of a ferromagnetic heat tube that is thermally coupled (welded) to the pipe to be heat traced. A non-magnetic conductor material (copper or aluminum) is placed inside the heat tube and connected to the tube at the far end. The tube and conductor are then connected to an AC voltage source in a series connection. When the voltage is applied in this manner, the current in conductor flows in one direction and returns through the steel tube in the opposite direction. The full current flows in inner surface of the steel tube and in its outer surface the current is virtually absent. This method of heating is called skin-effect heating because the return path of the circuit current is pulled to the inner surface (approximately 1 mm) of the heat tube by both the skin and the proximity effect between the heat tube and the conductor.

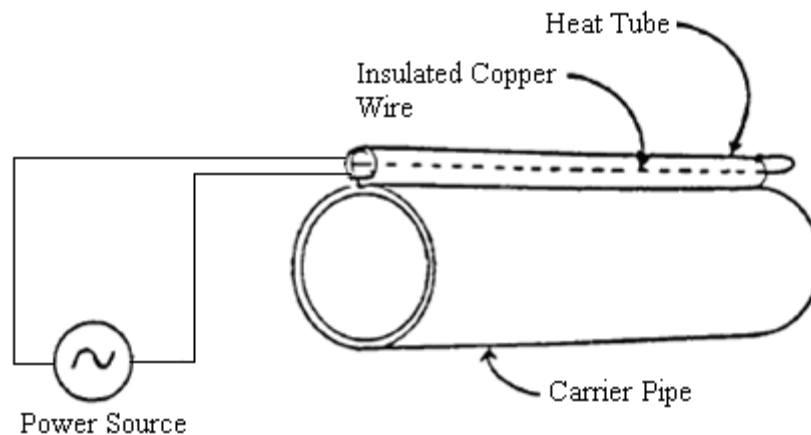

When the system is powered by high voltage (3 to 5kV) heat output occurs in both conductors. If the system is properly designed, 60 to 80% of heat output takes place in the steel tube, and only 20 to 40% in the inner conductor.

Features

- The STS circuit impedance is mainly resistive, generating heat in the heat tube wall and, to a lesser extent, in the insulated conductor. Additional heat results from eddy currents induced in the heat tube wall by the current flow through the insulated conductor;
- The heating element is specially treated tube of low-carbon steel having $\frac{3}{8}$ to $2\frac{1}{2}$ inch outer diameter and wall thickness not less than 3mm. The allowable circuit length is determined by the power output, heat tube size, conductor size, and the carrier pipe temperature;
- Non-magnetic conductor material (copper or aluminum) having $\frac{1}{2}$ to 2 in² cross section placed inside the tube;
- High power densities – up to 50 W/ft.

Advantages

- Most economical method for extremely long pipe lengths - up to 30 miles can be traced with a single electric supply point. This makes it most suitable for cross-country pipelines;
- Because of the welded contact between the tube and the pipe, higher heat transfer rates are attained;
- Because, the full current flows in inner surface of the skin heater's tube and in its outer surface the current is virtually absent the outer surface of heat-producing element (skin tube) has zero potential to ground. The tube is earthed and there are no electrical potentials, which make the system safe for maintenance staff.

Limitations

- Involve considerable custom design;
- Do not lend easily to the production of uniform heating, and IEEE rates the method as providing only moderate system efficiency;
- Installations cannot be modified, and the complete system fails with a single line break;

- Skin effect heat-tracing is generally not cost-effective for pipelines shorter than 5000 ft;
- Not practical for non-metallic or complex piping.

SELECTION & SIZING OF APPROPRIATE ELECTRIC TRACER

Each heat tracing methods have their own performance and application limitations; however three important criteria are: 1) output characteristics, 2) the ability to cut-to-length, and 3) the temperature limits.

Output Characteristics: The cables are selected based on the temperature to be maintained i.e. to ensure that sufficient watts/ft is available to overcome the worst case heat loss of the pipeline including compensation for the losses at flanges and valves, where it is difficult to install enough cable. Available outputs of heating cable are:

- max sheathed temperature of 400°F (up to 10 W/ft) for copper sheathed cable
- max sheathed temperature of 750°F (up to 30 W/ft) for cupro-nickel sheathed cable
- max sheathed temperature of 932°F (up to 70 W/ft) for tubular sheath of Alloy 825 (a high-nickel/chromium alloy)

As a rule – “Always select the heater with the lowest temperature rating that meets the requirement i.e. suffices the heat loss”. Choosing unnecessarily a high wattage heater may result in:

- Increased energy consumption;
- Safety problems associated with high temperatures;
- Increases the rate of corrosion;
- Obviously, the high power density will be more expensive because they are made from more costly heat-resistant polymers.

If the watt per foot rating of the cable selected is **less** than the heat loss per foot, the installation options are:

- Use of multiple straight runs;

- Spiral wrapping of the cable;
- Use of better insulation material and increasing the thickness.

The Ability to Cut-to-Length: This refers to the ability to adapt to field conditions without specialized training or tools. If a heater cannot be cut in the field it is referred to as 'fixed' length like MI series cable.

Cut-to-length heaters are divided into two subgroups: those that can be cut anywhere like self regulating cables and those that must be cut at specific locations or nodes (parallel heat tracing cables).

Temperature Limits: Each heater will have a maximum maintain temperature as well as a maximum exposure temperature. Heat tracers for industrial applications are typically selected according to the maximum temperature to which the tracer will be subjected and the power required for the tracer. The general guidance is:

1. Self-Regulating heating cables are commonly used for freeze protection and low temperature applications;
2. Parallel circuit zone heaters are typically used for applications which exceed the temperature ranges of self-regulating cables but fall below MI series resistance cables;
3. MI series-resistance heating cables can be used when circuit lengths exceed the ratings of conventional parallel-resistance heating cables and a single power source is needed;
4. Skin effect trace heating is most suitable for long cross-country pipelines.

TEMPERATURE CONTROL & SAFETY

All heat tracing systems are designed to cope with worst case situations and therefore a temperature control is necessary for energy conservation and protecting cable exceeding its limiting temperature. Control of the heat trace system is typically achieved by one of two methods: 1) ambient air sensing and 2) pipe sensing control.

Ambient Air Sensing Control:

When a large amount of winterization tracing is designed, an ambient sensing thermostat is recommended. The thermostat will sense the ambient temperatures and provide basic “on/off” temperature control i.e. as the ambient temperature falls below a certain level (typically 40°F to 50°F), the circuit will get energized to provide heating and at ambient temperatures above freezing, the control will turn OFF and no heating occurs. This type of control scheme has the following characteristics:

- A single temperature controller can control a whole group of circuits when the circuits are in the same ambient temperature environment;
- By controlling heat tracing with ambient sensing control, the status (flowing or non-flowing) of the heated pipe needs no consideration;
- A typical mechanical thermostat will monitor only the temperature, and no alarm functionality is provided. Without alarming, you may not realize there is a failure. If failed-closed, the thermostat will continue to energize the heater cable in a “runaway” condition. This could also present a serious issue, depending on the type of heater cable used, product being heated, and possibly area classification.

The primary application for ambient sensing control is freeze protection.

- When designing a heat trace system with relatively few circuits, temperature controls can be accomplished by using single-point on/off controls.
- If a large number of circuits are involved, it is common to provide control with a dedicated power distribution panel, which shall include an ambient sensing thermostat and a contactor for control. This type of control panel can normally be further enhanced with monitoring capabilities for voltage and current.

Pipe Sensing Control:

Pipe sensing control is used for process maintenance applications where the process temperature must be controlled within a moderate or narrow band. Here, Resistance Temperature Detectors (RTDs) are directly mounted on the pipe that provide real-time feedback for close tolerance temperature control. If fluid is flowing at a temperature above the control point, the heat tracing will turn off. In some cases, this may be necessary to prevent damage to the heat tracing being utilized. Also this method permits

a centralized location of the control panel from where any of the heater circuit temperature set points or alarm parameters may be adjusted. Typical alarm functionality for this type of panel includes both high and low temperatures, high and low current, RTD failures, and ground fault current leakage. The pipe sensing control strategy has the following characteristics:

- Only the precise amount of heat required to hold the pipe at design temperature is applied;
- In the range of -20°F to 42°F , pipe temperature is controlled by an “on-off” pipe-sensing control algorithm. Upon reaching 42°F (the upper end of the control band), the heat tracing is de-energized and the pipe will warm as the ambient temperature rises. This control strategy is applicable to all temperature maintenance applications.
- The primary disadvantage of a pipe-sensing control strategy is that most of the pipe branches need to be controlled by a separate control device, which increases the initial capital investment;
- Where a piping system has tees and therefore multiple flow paths, more than one thermostat may be required. Situations where more than one thermostat could be necessary include:
 - Pipes of varying diameters or insulation thicknesses;
 - Varying ambient conditions such as above/below ground transitions and indoor/outdoor transitions;
 - Flowing versus non-flowing conditions within the interconnected piping;
 - Applications involving temperature-sensitive products.

Pipe sensing control is the most energy-efficient strategy because a flowing pipe will typically not need any additional heat to keep it at the proper temperature and the control device will turn the heat tracing “on and off” within a prescribed control band around the required maintenance temperature. Similar to ambient control, a single-point thermostat can be used for small circuits and where large number of circuits is involved, a centralized panel board is often used. For more exact temperature control, a

microprocessor-based control panel may be considered which allows for monitoring, control, and alarming for both winterization and process maintenance heat tracing.

Power Supply

Trace heat cables may be connected to single-phase or to three-phase power supplies. Single phase heaters generally operate on 120 or 240 V. Generally 240-V heaters are preferred because they can support circuit lengths approximately twice as long as 120-V heaters can. It minimizes the number of circuits which is one of the most effective ways to reduce the first costs of an electric heat tracing system.

The three phase systems are fed via contactors similar to a three phase motor 'direct on line' starter which is controlled by a thermostat somewhere in the line. This ensures that the temperature is kept constant and the line does not overheat or under-heat.

Over-current & Earth Leakage Protection

The safety and performance of electric heat tracing depends on how the cable was selected, installed and eventually maintained. Improper handling, installation or maintenance of the cable could result in electrical shock, fire or cable failure. To minimize these risks, the codes require that all heat tracing applications utilize over-current and ground-fault protection.

Circuit breakers must be installed for protection against over-current. These must have sufficient capacity to allow for the inrush current of initial start-up, a feature unique to self-limiting heating tape, because of the variable power output/temperature characteristic. As a rule, size the circuit breaker for 25% more current than you calculate is needed based on the total heat trace cable load. Be sure to follow the manufacturer's recommendations for maximum circuit length.

Power distribution to the heat trace cable circuit is best supplied through a thermal magnetic style circuit breaker with integral GFI (Ground Fault Interrupt). The GFI is a mandatory requirement of NEC and is usually set at 30 mA with a nominal 100-ms response time to avoid nuisance tripping at lower temperatures. Ground fault protection however is NOT required where continued operation of power systems is necessary for safe operation of the equipment or process. This is because a ground fault condition,

which opens an overcurrent device protecting the heating cables/heating panels will bring the process to standstill and is not a desirable condition for critical applications. However in such scenarios, the heating wires or cables must have a grounded conductive covering.

Electric Tracing - Installation

A typical electric trace system will embrace:

1. Heating cable(s) together with termination components;
2. Ancillary items, such as junction boxes and fixing materials;
3. Temperature control devices;
4. Monitoring/alarm technologies (optional);
5. Power distribution/circuit protection facilities.

Figure below shows a typical electric heat trace system. It shows an electric cable strapped to the upper quadrant of the pipe with both pipe and cable jacketed under a thick insulating blanket to minimize thermal losses to the environment. A power connection kit is used to connect power to one end of the heating cable. An end seal kit is used to seal the other end of the heating cable. Splice and tee kits are used as necessary to connect two or three heating cables together.

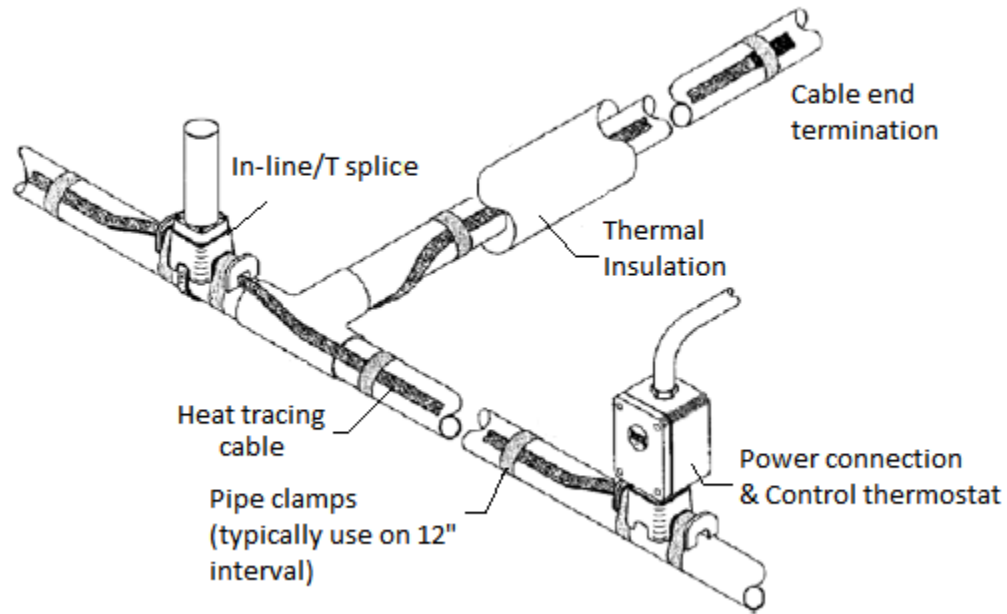

Electric Heat Trace of Pipe

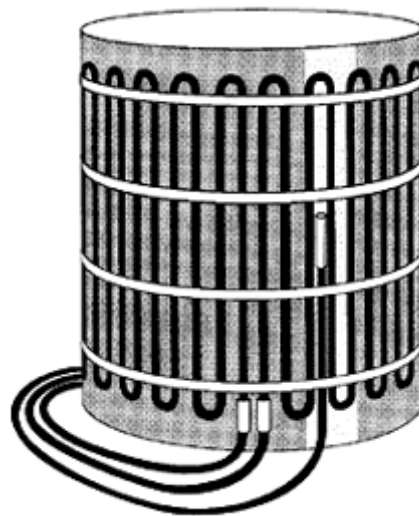

Electric Heat Trace of Tank

Electric Tracing - Good Practices

1. When a heat-traced pipe enters a facility, the heating cable should extend into the building at least 12". This prevents temperature drops due to air gaps or compression of the thermal insulation.

2. A similar situation exists when an above ground pipe goes underground. While the pipe may eventually travel below the frost line and therefore be protected from freezing, the distance between the surface (grade) and the frost line must be protected.
3. Where a freeze protection application has a main line with a short branch line connected to it, the heating cable installed on the main line can be looped (double passed) on the branch line. This eliminates the need to install a T-splice kit.
4. All of the heating cable power connection points should be secured to the piping. Heating cable should not pass through the air to travel to an adjoining pipe. Instead, use multiple circuit fabrication kits interconnected with conduit and field wiring.
5. The heat tracing cable shall be installed straight without overlapping. Special heat-conducting Aluminum tapes are available where heat is to be conducted from the tracing to the rest of the circumference of the pipe.

Codes, Approvals, and Standards

Pipe and electric heat tracing design information, installation and maintenance considerations are extensively covered by IEEE Standard 515-1997. Additional information and requirements can be referred in:

1. FM Factory Mutual Research Corporation
2. NFPA National Electrical Code under Article 427
3. NEC U.S. National Electric Code (NFPA 70)
4. NEMA National Electrical Manufacturers Association
5. NESC National Electrical Safety Code
6. UL 746B Underwriters' Laboratories, Inc.
7. ANSI American National Standards Institute
8. IEC 216 International Electro-Mechanical Commission

SECTION – 2: OVERVIEW OF STEAM HEAT TRACING

Steam tracing refers to using steam to indirectly elevate the temperature of a product using jacketed pipes or tubing filled with saturated steam. Steam tracing is often the preferred alternative in industrial plants where the steam distribution and return system is wide spread and in close proximity to the piping and equipment to be heat traced. One of the best ways to maximize steam tracer efficiency is to use steam that would otherwise be wasted: in other words, flash steam. The return on the investment the plant makes in the equipment required to recover this flash steam is quickly paid back, typically within a year. On negative side, steam is more expensive to install and maintain than electric heat tracing. Periodic leaks and inadequate controls in a steam-traced systems wastes energy and demand frequent repair and replacement.

Types of Steam Heat Tracing Systems

1. External Tube Tracers
2. Cemented Tracers
3. Fully Jacketed Pipe

EXTERNAL TUBE TRACERS

External tube tracing consists of one or more ½” or 1” tubing; clipped or wired on to the main product line. The maximum heat flow is achieved when the tracer is in tight contact with the product line. Where the temperature difference between the tracer and the product is low, the tracer may be welded to the product line.

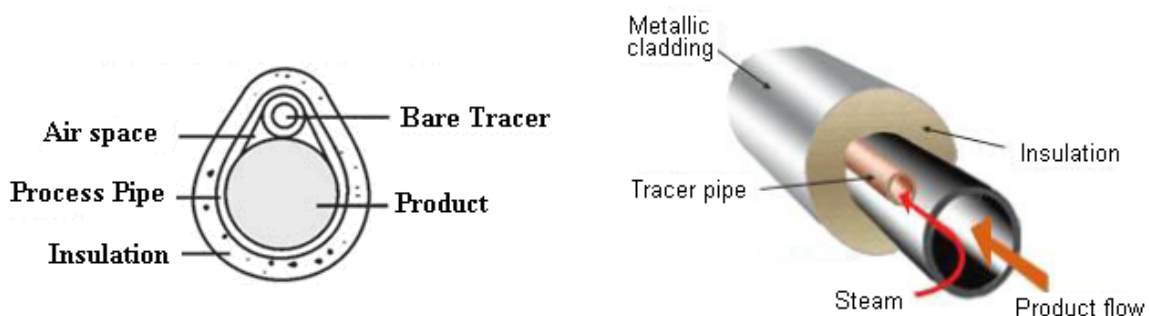

External Tracer Attached to Product Line

CEMENTED TRACERS

Cemented steam tracing is similar to external tube tracer with a difference that a conductive compound is smeared between the two pipes so that more surface area is available for heat transfer. The cemented tracers are anchored with stainless steel straps to ensure that the steam tracers and heat transfer compound are permanently fixed to the surface of the process pipe and insulation is applied thereafter.

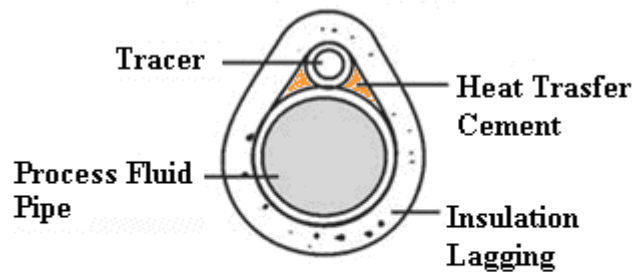

Cemented Tracer

Cemented heat tracers are also called conduction tracers, since the primary method of heat transfer is by conduction. This differs to external bare tube tracers where the primary method for heat transfer is by convection and radiation. Use of conduction-type tracers is recommended when process temperatures exceed 175°F. Bare convection tracers are economically justified for freeze protection applications.

JACKETED PIPING

If the fluid line or process pipe temperature is required to approach closely that of the available steam, a jacketed pipe arrangement may be essential. A steam-jacketed pipe has a larger pipe surrounding the product pipe. Steam is carried in the annular region between the two pipes, which allows the heating medium to directly contact the entire surface of the process pipe, providing maximum heat transfer area. Typically, a jacketed system will maintain the product near the steam temperature (when there is little or no flow in the pipeline).

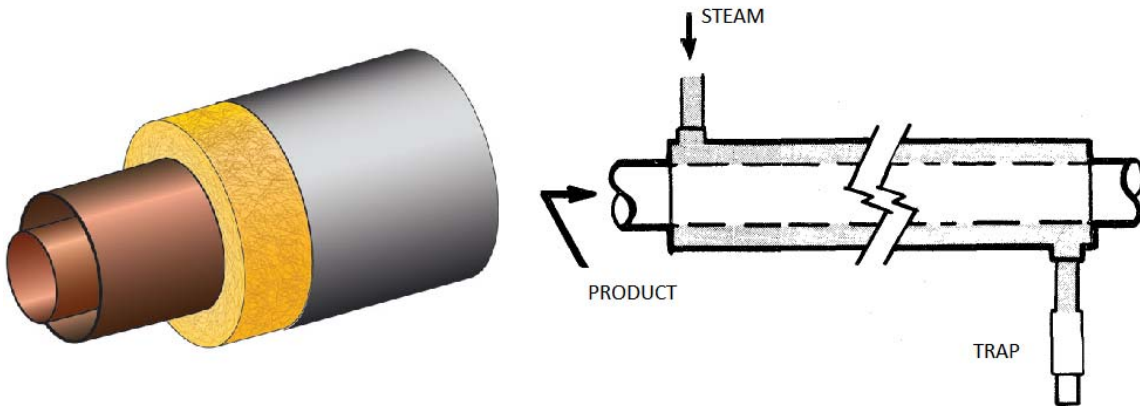

Ideally jacketed lines should be constructed in no more than 20 ft lengths and the condensate removed from each section. Steam should enter at the highest end so that there is a natural fall to the condensate out let. When it is considered impractical to trap each length, a number of lengths up to a total of 80-100 ft approx may be formed together in moderate climates, but in extremely cold parts of the world 40 ft should be the maximum. As a general guide refer table for steam connection size for jacketed lines.

Product line size	Jacket size	Steam connection
2½"	4"	½"
3"	6"	¾"
4"	6"	¾"
6"	10"	¾"
8"	10"	1"
10"	12"	1"

The steam jacket provides somewhat higher heat transfer rates than conduction tracers; but it has its drawbacks:

- Very high heat transfer rates associated with jacket piping demands high steam flow rates that lead to high energy costs;
- Capital cost is high;
- Special pipe fittings, trap stations and skilled welders required;
- Construction time is long, and the final system cannot be easily adapted or modified;
- System is very expensive to maintain. Leakage or failure of the system is difficult to locate. Where failure does occur, it may cause cross contamination and hazard.

STEAM TRACING DESIGN CONSIDERATIONS

One of the prerequisite for steam heat tracing system is that the steam supply should always be continuously available even during a normal shut down period.

A typical steam tracing system consists of:

1. **Boiler:** Generates steam at certain pressure.
2. **Steam Header:** Steam exits the boiler through piping referred to as the steam header. The header also serves as a reservoir that feeds steam to the individual heating circuits.
3. **Steam Manifold:** The manifold serves as the branch point for supplying the individual heating circuits - one branch corresponding to each tracer circuit.
4. **Condensate Manifold:** The condensate manifold resembles the steam manifold to which branch condensate circuits are attached.
5. **Condensate Header:** Condensate from each of the condensate manifolds flows into a common pipe referred to as the condensate header. The condensate header returns liquid water to the boiler so that it can be reheated into steam.
6. **Steam Traps:** An automatic valve that allows condensate, air and other non-condensable gases to be discharged from the steam system while holding or trapping the steam in the system.

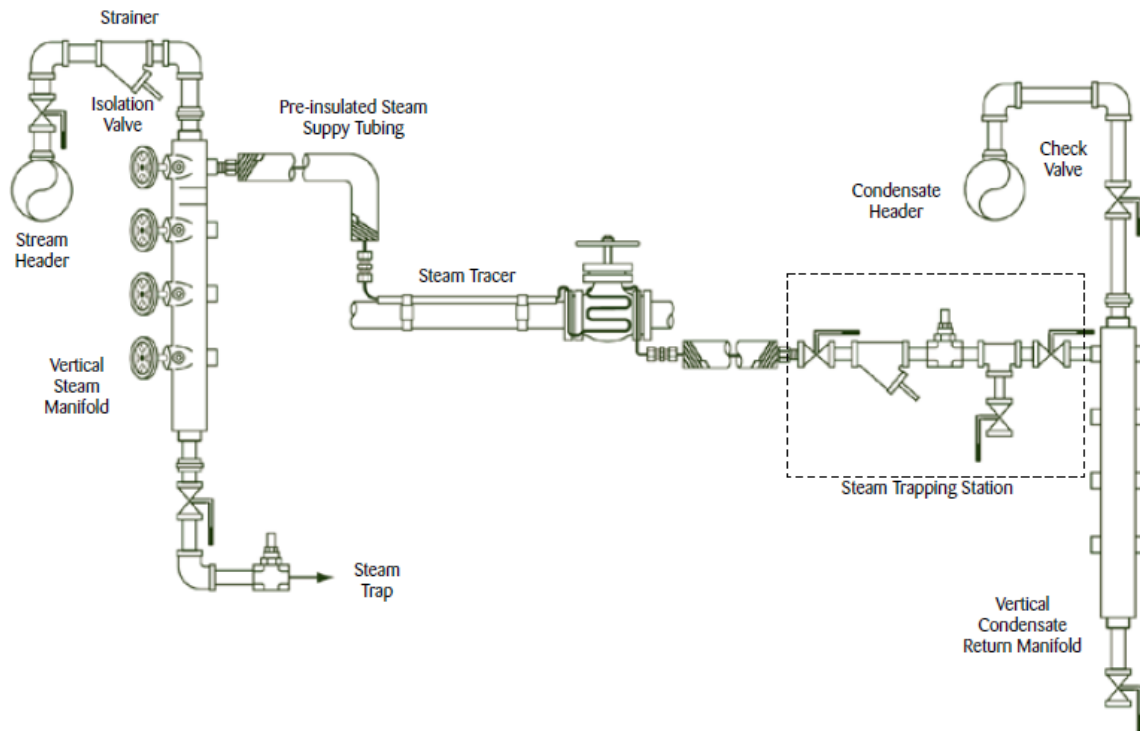

Typical Steam Tracing System (Figure Source: Thermon)

Tracer Materials

Sch. 80 carbon steel pipe, copper or stainless steel tubing is used for tracers. Selection is based on steam pressure and required tracer size. Tracers are either 3/8" or 1/2" size with copper tubing being the most economical installation.

Steam Pressure

Tracer lines may have to work at any steam pressure (usually @ 30 to 150 psig (298°F and 367°F) but always choose the lowest pressure to give the required product temperature. The figure below illustrates pressure-temperature relationship:

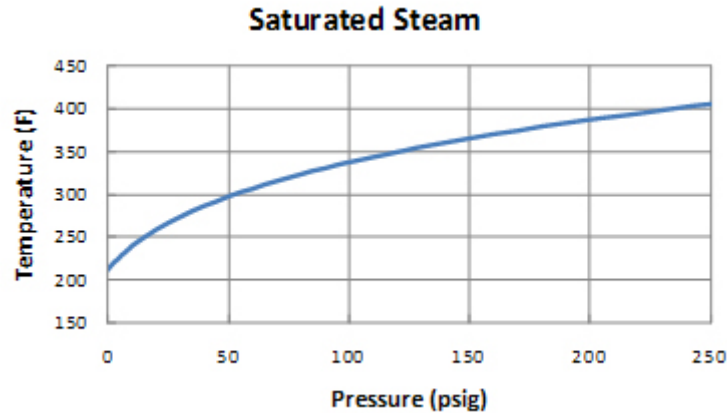

Steam pressure must be maintained for two reasons:

- To maintain the requisite temperature;
- To ensure condensate return.

The steam pressure should be selected to meet the tracing application, but not excessive due to the added thermal stresses a higher steam pressure will cause on the tracing components. Excessively high steam pressures will waste energy and it is necessary to install a suitable pressure reducing valve if the plant's steam pressure is too high.

Tracer Size, Length and Configuration

Tracers are usually 1/2", 3/4" or 1" size. The size is based on steam flow rate at velocity criteria of 65 ft/sec.

The maximum permissible length of tracer will depend on the size of tracer tube and also the steam pressure but as a rule follow table below as a general guide.

Steam Pressure, psi	Size of Tracer		
	1/2"	3/4"	1"
Maximum Length of Tracer (ft)			
15 -50	75	100	125
50 -150	150	175	200

Steam Pressure, psi	Size of Tracer		
	1/2"	3/4"	1"
	Maximum Length of Tracer (ft)		
150 -200	200	225	250

Determining the Number of Required Tracers

The number of tracers will depend on the amount of heat required and the size of the process pipe. If possible, the plant should try to limit the number of steam tracer lines to one for each product pipe. Adding more tracers will require additional connections to the supply and return header and the associated valve and fittings required for the connections. The size of the steam manifold will, of course, depend upon the steam pressure and the total load on the tracers but the following, table – below is suggested as a general guide:

Steam Manifold Size*	Number of 1/2" Tracers
3/4"	2 - 3
1"	4 - 6
1 1/2"	7 - 15

A new steam heating circuit must be established before the steam loses too much pressure but as a good engineering practice “No more than 15 tracers shall be served by one distribution header”.

The tracer length is generally limited to 150 feet. For longer lengths, engineering is required. The plant should consider the steam header size, pressure drop from fittings, valves, bends, increases in elevation, and return system pressures when determining a process line length.

Condensate Return System

The steam tracing system typically doesn't modulate the steam pressure to the steam tracer system; therefore, the plant can use a pressurized condensate system to recover

the condensate. The pressurized condensate system will have very high thermal steam cycle efficiency. Pressurized condensate systems operate continuously at a pressure above 15 psig, and the condensate return system isn't vented to the atmosphere. The pressure in the condensate system is sustained by the dynamics of the system or a systematic control process loop. Typical condensate systems operate with some backpressure due to condensate line under sizing.

Steam Trapping

Similar to any steam applications, a steam trap must be used on the end of the steam tubing to discharge unwanted condensate. A steam trap is an automatic valve that allows condensate, air and other non-condensable gases to be discharged from the steam system while holding or trapping the steam in the system. Its sole purpose is to retain the steam until its latent heat is fully used and to discharge the condensate and non-condensable gases. Several different types of steam trap technologies exist to accomplish this extremely critical and necessary task. (Refer following section for details).

Special attention must be given to the piping design of the condensate header to avoid excessive pressure drop which could impede operation of the steam jacketing system. The condensate discharge should preferably enter the manifold through swept connections and the headers should be adequately sized as below:

Number of ½" Tracers	Condensate Manifold Size
1 to 5	1"
6 to 10	1½"
11 to 15	2"

Steam Traps

Explained below are the type of traps, their functions, their advantages and disadvantages, and when each should be applied.

1. **Mechanical:** Mechanical steam traps operate by use of a float device connected to a mechanical linkage that reacts upon changes in volume or fluid density. There are two main types of mechanical traps: the float & thermostatic (F&T) trap and the inverted bucket trap.
 - The inverted bucket trap uses an inverted bucket as a float device connected by a linkage to the valve plug. The varying densities between condensate and steam are used to create a buoyancy force on the bucket to open and close the valve. Most inverted bucket traps incorporate a small bleed hole to allow any air in the system to escape. Inverted bucket traps are the most robust choice for steam jacketed systems as they require no special considerations.
 - Float traps feature a ball inside the trap housing. When steam or air is in the trap, the ball rests on the trap floor. When condensate enters the trap, the ball floats on the condensate and rises, the orifice opens, and condensate escapes. The orifice is located in the liquid level, requiring additional air purging capability to avoid air lock. Provided some form of continual air purging is incorporated in the trap design, float traps can function well in a steam jacketed system.
2. **Thermodynamic:** Thermodynamic steam traps operate in a cyclic on/off process using the thermodynamic properties of flash steam as it flows through the trap. Thermodynamic traps use only one moving part, the valve disc, which allows condensate to escape when present and closes tightly upon the arrival of steam. These traps have an inherently rugged design and are commonly used as drip traps on steam mains and supply lines. Their solid construction and single moving part make them resistant to water hammer and are freeze proof when installed vertically. Thermodynamic traps will only discharge small amounts of air and therefore are typically not used in process applications.
3. **Thermostatic:** Thermostatic steam traps operate under the direct influence of increasing or decreasing temperature within the body of the trap. These traps feature either a bi-metallic strip or a bellows type fluid-filled diaphragm.
 - The bi-metallic steam traps operate under the principle of thermal expansion of metals. Two dissimilar metals are joined into a series of discs and upon heating

will deflect to provide movement to close off the valve. These traps are primarily used in steam tracing because of their ability to adjust condensate discharge temperature which may be desirable on certain tracing applications.

- The bellows type thermostatic trap uses a fluid-filled diaphragm that operates under the principle of thermal expansion and contraction. The fluid vaporizes and expands as the temperature increases, causing the bellows to close the valve. As the temperature decreases, the fluid condenses and contracts, causing the bellows to open the valve. These traps provide excellent air handling capability and are used for drip, tracing and process applications. The main advantage of the thermal element is that on start-up loads, the trap is in the open position, allowing air and condensate to be rapidly removed from the system.

Thermostatic traps are suitable for the majority of steam tracing applications. In order for a thermostatic trap to open, condensate must dwell in the trap long enough for its temperature to drop well below the steam temperature. To achieve the necessary sub-cooling, condensate must back up in the piping/tubing just upstream of the trap, and this can cause condensate to back up inside the jacketing. For this reason, thermostatic traps are not recommended for steam jacketing systems.

Thermodynamic traps are the simplest and most robust of all traps. They discharge condensate at a temperature close to that of steam, thus they are especially suitable on those critical tracing applications where the holding back of condensate in the tracer line until it has sub-cooled would be unacceptable. It must be remembered that every time a thermodynamic trap opens, it discharges condensate at the maximum rate corresponding to the differential pressure applied. The instantaneous release rates of the steam flashing off the condensate can be appreciable, and care is needed to ensure that condensate return lines are adequately sized, if high back pressures are to be avoided. Thus, the use of swept connections from trap discharges into common headers of generous size will help avoid problems.

Therefore, for critical steam tracing applications, where no back-up of condensate can be tolerated, thermodynamic traps should be used.

Temperature Control

The temperature of steam tracing circuits can be controlled by:

1. Pressure reducing valves which vary the steam pressure and thus the steam temperature;
2. Isolated tracers which provide a low conductive path to reduce temperatures and conserve energy or for holding pipeline temperatures with 150 psig to 250 psig steam without the need for pressure reducing valves that might be necessary for bare steam tracers in order to limit the heat output;
3. Self-acting control valves with sensors responding to the ambient air temperature or the process pipe temperature;
4. Fixed-temperature discharge steam traps or balanced pressure traps which respond to condensate temperature and allow condensate to sub cool within the tracer before being discharged;
5. Thermostatically controlled solenoid valves, which can provide an off-on operation. The thermostat serves only pilot duty, and off-on control provides the tracer circuit with the full benefit of the heating media during startup.

STEAM TRACING INSTALLTION TIPS

As is true with any piping system, proper installation procedures are essential to insure tracer line efficiency. Find below few good engineering practices:

1. All distribution or supply lines should be installed at an elevation above the highest point of lines requiring steam tracing and as far as possible the condensate – collection or return lines should be located at an elevation low enough to permit gravity flow from all connected lines.
2. The steam supply for the tracer system should be connected at the top of the main steam header to ensure there is no condensate entrained in the steam supply. Individual tracers should take off from the top of the header with an isolating valve provided.
3. Run tracers parallel to and against the underside of the pipe to be heated. When a single tracer line is used, the line shall be placed under the fluid pipe. When

there are two tracers, these are normally placed under the fluid pipe about 30° apart.

4. Condensate is drained from the steam tracer system through gravity; therefore, the plant should review the following items:
 - Ensure there are no low spots in the tracer run.
 - Don't wrap the tracer around the process pipe. Condensate can and will build up in the low spots until it fills the tube, which will result in poor heating and possibly water hammer.
 - Steam tracer installation should flow from the highest elevation to the lowest.
 - If possible, slope the tracer to the steam trap station.
5. Tracers should be installed on the bottom of the process pipe for greater efficiency.
6. The correct support will prevent sagging on the steam tracer line and ensure the tracer line is in contact with the process pipe. Uneven contact between the steam tracer and process pipe produces an uneven distribution of temperature. This effect becomes more significant as the temperature difference between pipe and tracer increases. When the steam becomes superheated, the temperature difference reaches a maximum.
7. The tracer line will expand and contract; therefore, the forces of expansion and contraction must be designed into the system. A horizontal tracer line tends to expand more than the primary fluid pipe. An ideal point at which to allow for this expansion is around the flange or an elbow.
8. The tubing material and fitting material should be the same.
9. Don't install tracing connections under the insulation. Install the connections at points that will allow the process equipment to be easily removed or repaired.
10. Tracer steam supply valves and steam trap stations should be marked for easy to identification. This will provide faster maintenance on the tracer lines because they will be easy to isolate.

11. Use preassembled steam and condensate return headers. These systems will typically have fewer connection points and will be designed to handle the steam loads.
12. Tube tracer circuits should be constructed 100 feet to 300 feet in section length and the condensate is removed from each section through a steam trap placed in this interval.

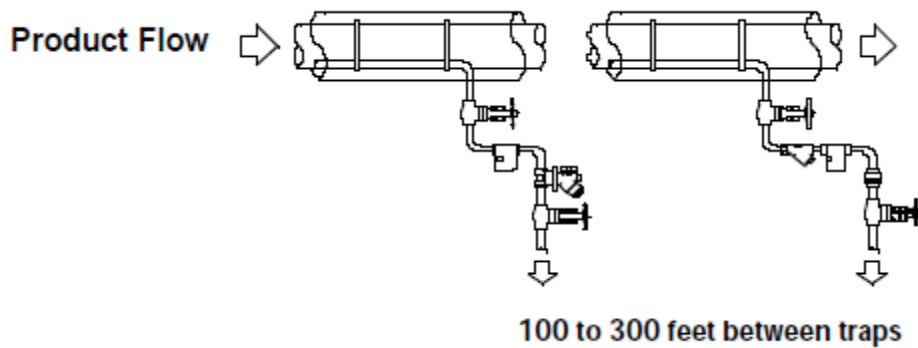

Distance between Traps (External Tracers); Fig. Source: Spirax Sarco

Jacketed lines are constructed in approximately 20-foot lengths and the condensate is removed from each section. Generally 40-foot lengths are the maximum lengths for removing the condensate at trapping stations. It implies more steam traps compared to external tube tracers.

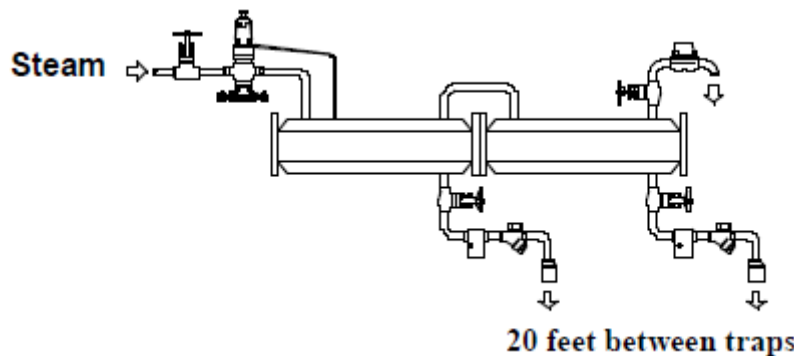

Distance between Traps (Jacket Pipe); Fig. Source: Spirax Sarco

Potential Steam Tracing Failures

The inability to achieve precise temperature control is attributed to three factors operating in tandem.

1. Saturated steam is delivered at the desired pressure by means of a pressure reducing valve. As the pressure is reduced, the saturated steam becomes superheated. The excess heat is rapidly dissipated in the system.
2. Uneven contact between the steam tracer and process pipe produces an uneven distribution of temperature. This effect becomes more significant as the temperature difference between pipe and tracer increases. When the steam becomes superheated, the temperature difference reaches a maximum.

While these systems are fairly stable and safe when designed properly, they still require relief valves and other safety measures that can be used to address concerns such as pressure buildups. It is also necessary to be able to periodically clean the pipework to remove built-up impurities deposited on the wall of the pipe over time. Service requirements for the main pipe must also be built into the design.

Safety Considerations

All steam tracer lines above the pressure of 15 psig fall within the ASME B31.1 code; thus, all components used should meet the code requirements. All supply and discharge lines feeding the tracer system should be insulated for energy conservation and personnel protection.

SECTION - 3: ESTIMATING HEAT TRACE REQUIREMENTS

The theory of maintaining temperature of pipe carrying process fluid or freeze protection evolves around a very simple heat balance i.e. the heat input must be a little higher than the heat loss. This section provides a step-by-step approach for the design, specification, and selection of a bill of materials for an electric heat tracing system.

Heat Loss

The first step in designing a heat trace system is to determine the heat loss from each pipe or tank to be traced. Heat loss is the amount of heat given up to the surrounding atmosphere through a combination of conduction, convection, and radiation. The equation and parameters required to determine the total heat losses on a given pipe is given by:

$$W = \frac{2\pi (T_m - T_a)}{3.42 \times 12 \left(\frac{\ln \frac{D_i}{D_p}}{K_i} + \frac{\ln \frac{D_j}{D_i}}{K_j} \right)} \times S_f$$

Where:

- W = Watts per foot of pipe ($W \times 3.414 = \text{Btu/hr}$)
- T_m = Maintained temperature, °F
- T_a = Ambient temperature, °F
- Ln = Natural log
- D_i = outside diameter of insulation (in)
- D_p = outside diameter of pipe (in)
- K_i = K value of insulation ($\text{BTU} \cdot \text{in} / \text{hr} \cdot \text{ft}^2 \cdot ^\circ\text{F}$)
- D_j = outside diameter of jacket (in)
- K_j = K value of jacket ($\text{BTU} \cdot \text{in} / \text{hr} \cdot \text{ft}^2 \cdot ^\circ\text{F}$)
- S_f = Safety Factor

Diameters for (Di/Dp) taken as 3/1 for 1" pipe +1" insulation and is typical for all other combinations.

Empirical Method of Estimating Heat Loss

Collect the following data for each pipe.

Parameters	Data
Maintenance Temperature, Tm:	_____
Minimum Ambient Temperature, Ta:	_____
Nominal Pipe Size:	_____
Thermal Insulation Thickness:	_____
Thermal Insulation Type:	_____
Location, Indoor/ Outdoor:	_____
Additional Safety Factor:	_____

Follow the steps below to determine the heat loss.

STEP 1 – Determine the application ΔT

ΔT is the difference between the desired Fluid Maintain Temperature (Tm) and the Minimum Ambient Temperature (Ta).

STEP 2 – Determine the application heat loss (Watts per foot, W/ft)

Refer to Table 1 "Base Heat Loss Table for Insulated Pipes". The table shows heat loss from insulated metal pipes at given insulation thickness per °F temperature differential. The values are shown in watts per foot of pipe.

Table -1
Heat Loss for Insulated Pipes (Watts per sq-foot)

INSULATION THICKNESS (in.)	DELTA T °F	NOMINAL PIPE SIZE (in.)																			
		.50	.75	1	1.25	1.50	2	2.50	3	4	6	8	10	12	14	16	18	20	24	30	
		ACTUAL O.D. (in.)																			
		.68	.84	1.32	1.66	1.90	2.38	2.88	3.50	4.50	6.63	8.63	10.75	12.75	14	16	18	20	24	30	
.50	50	2.1	2.4	3.3	3.9	4.4	5.3	6.2	7.3	9.1	13.0	16.6	20.4	24.0	26.2	29.8	33.4	37.0	44.1	54.7	
.50	150	4.1	4.8	6.6	7.9	8.8	10.5	12.3	14.6	18.3	26.0	33.2	40.8	48.0	52.5	59.6	66.8	73.9	88.1	109.7	
.50	200	6.2	7.1	9.9	11.8	13.1	15.8	18.5	22.0	27.4	39.0	49.8	61.3	72.0	78.7	89.5	100.2	110.9	132.2	164.1	
.50	250	8.2	9.5	13.1	15.7	17.5	21.0	24.7	29.3	36.6	52.0	66.4	81.7	96.0	105.0	119.3	133.6	147.8	176.3	218.8	
.50	300	10.3	11.9	16.4	19.7	21.9	26.3	30.9	36.6	45.7	65.0	83.0	102.1	120.0	131.2	149.1	167.0	184.8	220.3	273.5	
.50	300	12.3	14.3	19.7	23.6	26.3	31.5	37.0	43.9	54.8	78.0	99.6	122.5	144.1	157.5	178.9	200.4	221.7	264.4	328.2	
1.00	50	1.4	1.6	2.0	2.4	2.6	3.1	3.6	4.2	5.1	7.1	9.0	10.9	12.8	14.0	15.8	17.7	19.5	23.2	28.7	
1.00	100	2.8	3.1	4.1	4.8	5.2	6.2	7.1	8.3	10.2	14.2	17.9	21.9	25.6	27.9	31.6	35.3	39.0	46.4	57.5	
1.00	150	4.1	4.7	6.1	7.2	7.9	9.3	10.7	12.5	15.3	21.3	26.9	32.8	38.4	41.9	47.4	53.0	58.5	69.6	86.2	
1.00	200	5.5	6.2	8.2	9.5	10.5	12.3	14.3	16.6	20.4	28.4	35.9	43.8	51.2	55.8	63.2	70.6	78.0	92.8	114.9	
1.00	250	6.9	7.8	10.2	11.9	13.1	15.4	17.8	20.8	25.5	35.5	44.8	54.7	64.0	69.8	79.0	88.3	97.5	116.0	143.7	
1.00	300	8.3	9.3	12.3	14.3	15.7	18.5	21.4	25.0	30.6	42.6	53.8	65.6	76.8	83.7	94.9	106.0	117.1	139.2	172.4	
1.50	50	1.1	1.3	1.6	1.8	2.0	2.3	2.7	3.1	3.7	5.1	6.3	7.7	8.9	9.7	10.9	12.2	13.4	15.9	19.7	
1.50	100	2.2	2.5	3.2	3.7	4.0	4.6	5.3	6.1	7.4	10.1	12.6	15.3	17.8	19.4	21.9	24.4	26.9	31.9	39.4	
1.50	150	3.4	3.8	4.8	5.5	6.0	7.0	8.0	9.2	11.1	15.2	19.0	23.0	26.7	29.1	32.8	36.6	40.3	47.8	59.0	
1.50	200	4.5	5.0	6.4	7.4	8.0	9.3	10.6	12.2	14.8	20.2	25.3	30.6	35.6	38.8	43.8	48.8	53.8	63.8	78.7	
1.50	250	5.6	6.3	8.0	9.2	10.0	11.6	13.3	15.3	18.5	25.3	31.6	38.3	44.6	48.5	54.7	61.0	67.2	79.7	98.4	
1.50	300	6.7	7.5	9.6	11.0	12.0	13.9	15.9	18.4	22.2	30.3	37.9	45.9	53.5	58.2	65.7	73.2	80.7	95.6	118.1	
2.00	50	1.0	1.1	1.4	1.6	1.7	1.9	2.2	2.5	3.0	4.0	5.0	6.0	6.9	7.5	8.5	9.4	10.4	12.2	15.1	
2.00	100	2.0	2.2	2.7	3.1	3.4	3.9	4.4	5.0	6.0	8.0	9.9	12.0	13.9	15.1	16.9	18.6	20.7	24.5	30.1	
2.00	150	3.0	3.3	4.1	4.7	5.0	5.8	6.5	7.5	9.0	12.0	14.9	18.0	20.8	22.6	25.4	28.2	31.1	36.7	45.2	
2.00	200	3.9	4.4	5.5	6.2	6.7	7.7	8.7	10.0	11.9	16.1	19.9	23.9	27.7	30.1	33.9	37.7	41.4	49.0	60.3	
2.00	250	4.9	5.4	6.8	7.8	8.4	9.6	10.9	12.5	14.9	20.1	24.9	29.9	34.7	37.6	42.4	47.1	51.8	61.2	75.3	
2.00	300	5.9	6.5	8.2	9.3	10.1	11.6	13.1	15.0	17.9	24.1	29.8	35.9	41.6	45.2	50.8	56.5	62.2	73.5	90.4	
2.50	50	.9	1.0	1.2	1.4	1.5	1.7	1.9	2.1	2.5	3.4	4.2	5.0	5.7	6.2	7.0	7.7	8.5	10.0	12.3	
2.50	100	1.8	2.0	2.4	2.7	3.0	3.4	3.8	4.3	5.1	6.8	8.3	9.9	11.5	12.4	13.9	15.5	17.0	20.0	24.6	
2.50	150	2.7	3.0	3.6	4.1	4.4	5.0	5.7	6.4	7.6	10.1	12.5	14.9	17.2	18.6	20.9	23.2	25.5	30.0	36.8	
2.50	200	3.6	3.9	4.9	5.5	5.9	6.7	7.6	8.6	10.2	13.5	16.6	19.9	22.9	24.8	27.9	30.9	34.0	40.0	49.1	
2.50	250	4.5	4.9	6.1	6.9	7.4	8.4	9.5	10.7	12.7	16.9	20.8	24.9	28.7	31.1	34.9	38.7	42.5	50.0	61.4	
2.50	300	5.4	5.9	7.3	8.2	8.9	10.1	11.3	12.9	15.3	20.3	24.9	29.8	34.4	37.3	41.8	46.4	50.9	60.0	73.7	
3.00	50	.8	.9	1.1	1.2	1.3	1.5	1.7	1.9	2.2	3.0	3.6	4.3	4.9	5.3	6.0	6.6	7.2	8.5	10.4	
3.00	100	1.7	1.8	2.2	2.5	2.7	3.0	3.4	3.8	4.5	5.9	7.2	8.6	9.9	10.7	11.9	13.2	14.5	17.0	20.8	
3.00	150	2.5	2.7	3.3	3.7	4.0	4.5	5.1	5.7	6.7	8.9	10.8	12.9	14.8	16.0	17.9	19.8	21.7	25.5	31.2	
3.00	200	3.3	3.6	4.5	5.0	5.4	6.1	6.8	7.6	9.0	11.8	14.4	17.2	19.7	21.3	23.9	26.4	28.9	34.0	41.6	
3.00	250	4.2	4.6	5.6	6.2	6.7	7.6	8.5	9.5	11.2	14.8	18.0	21.4	24.6	26.5	29.8	33.0	36.2	42.5	52.0	
3.00	300	5.0	5.5	6.7	7.5	8.0	9.1	10.2	11.5	13.5	17.7	21.6	25.7	29.6	32.0	35.8	39.6	43.4	51.0	62.4	

STEP 3 – Adjust the heat loss by applying insulation factor

The base heat losses shown in Table 1 have been calculated using the K factor for fiberglass insulation. Use Table 2 "Insulation Adjustment Factors" and multiply the base heat losses by the Adjustment Factor for the insulation being used.

**Table – 2
Thermal Insulation Adjustment Factors**

Insulation Type	Insulation K Factor	Adjustment Factor
-----------------	---------------------	-------------------

Insulation Type	Insulation K Factor	Adjustment Factor
Polyurethane	0.165	0.66
Polyisocyanurate	0.180	0.67
Polystyrene	0.220	0.88
Fibreglass	0.250	1.00
Foamed Elastomer	0.290	1.16
Mineral Wool	0.300	1.20
Expanded Perlite	0.375	1.50
Calcium Silicate	0.375	1.50
Cellular Glass	0.400	1.60

STEP 4 – Adjust for indoor/outdoor applications

Multiply the value determined in Step 3 by 0.9 for all indoor applications.

STEP 5 – Add Safety Factor

A safety factor of 10% has been used throughout the above calculations. If a different value is desired, adjust the value calculated in Step 4 accordingly.

STEP 6 – Add Allowance for Valves

Additional heat will be required to offset the higher levels of heat loss associated with valves. Calculate the heat loss for each valve within the piping system by multiplying the final base heat loss calculated in Step 5 by the appropriate Heat Loss Factor shown in Table below.

Table-3

Adjustment Factors for Valves

Type of Valve	Heat Loss Factor
Gate	4.3
Ball	2.6
Butterfly	2.3
Globe	3.9
Check	2.0

STEP 7 - Add Allowance for Pipe Supports

Use the following formula to determine the heat loss for each size of support within the piping system.

Heat loss per support = $0.7L (\Delta T)$,

Where

- L equals the length of the support in feet and
- ΔT equals $T_m - T_a$ as per Step 1.

EXAMPLEGiven Parameters

1. Desired Fluid Maintain Temperature (T_m) = 80°F
2. Minimum Expected Ambient Temperature = -20°F
3. Pipe Size = 6 inches diameter
4. Pipe Length = 100 ft
5. Heat Sinks = Four Gate Valves
6. Pipe Supports = Ten, each 1 ft long

7. Thermal Insulation Thickness = 2 inches
8. Thermal Insulation Type = Polyurethane
9. Location = Outdoors
10. Desired Safety Factor = 20%

Solution

1. Application ΔT ($T_m - T_a$) = $80 - (-20) = 100^\circ\text{F}$
2. From Table 1, base heat loss: 8.0 W/ft
3. Adjust base heat loss using Table 2: $8.0 \times 0.67 = 5.36$ W/ft
4. Outdoor application, no adjustment required
5. Add desired Safety Factor (10% already included): $5.36 \times 1.1 = 5.9$ W/ft
6. Total adder per Valve using Table 3: $5.9 \times 4.3 = 23.37$ W
7. Total adder per Pipe Support: $0.7 \times 1 \times 100 = 70$ W

Total heat losses from piping System

- Total pipe losses = $5.9 \times 100 = 549.0$ Watts
- Total valve losses = $23.37 \times 4 = 93.48$ Watts
- Total pipe support losses = $70 \times 10 = 700.0$ Watts
- TOTAL HEAT LOSS (WATTS) = 1,342.48 Watts

SELECT CABLE TYPE AND OUTPUT RATING

Once the heat loss and the total length of heating cable is established, the next step is to select cable type and output rating.

Constant Wattage Cable

The cable heat output should be equal or greater than the heat loss Q. To design a constant wattage MI cable, use the following steps:

1. Step 1: Calculate the heat loss, Q in W/Ft as described in previous paragraph
2. Step 2: Determine the overall heating cable length, L.

3. Step 3: Determine the operating voltage, V.
4. Step 4: Calculate the necessary resistance per foot, Ω/ft using equation:

$$\Omega/\text{ft} = V^2 / (Q * L^2)$$

This value is the minimum resistance value in ohms/foot that will provide the desired heat output to offset the heat loss Q, calculated in step 1.

Use the manufacturer's resistance tables to select an 'actual' Ω/ft value equal to the value calculated in Step 4. If no value is equal, select the next lower value.

Note: Selecting a value higher than the value calculated in Step 4 results in heat output below the minimum required heat output and will not offset all of the heat loss of the system.

Using the new selected Ω/ft value from above, calculate the actual W/Ft and total watts of the cable.

$$Q \text{ (W/ft)} = V^2 / (\Omega/\text{ft} * L^2)$$

$$W = W/\text{ft} * L$$

W/Ft should be equal or greater than the heat loss Q. If not, review the calculations for errors.

Self Regulating Cable

When using self-regulating cable, use the manufacturer's graphs or charts to select appropriate output rating. The example below illustrates a typical example:

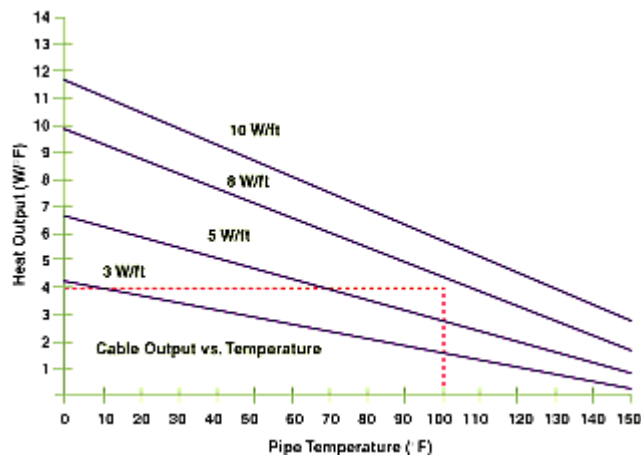

In this example, assume that the self-regulating cable is installed on plastic piping and over-wrapped with aluminum tape. The pipe maintenance temperature is assumed to be 100°F (38°C) and the calculation of overall heat loss is 4 W/ft. A vertical line is drawn upward from 100°F on the X-axis. A horizontal line is drawn from the heat loss value of 4 W/ft until it intersects the vertical line you drew. Select the cable with the wattage rating curve that lies above the intersection of the two lines - that is, the cable rated 8 W/ft.

Caution: If the cable's output rating is different from supply voltage than apply the correction factors in accordance to the manufacturer's derating tables or curves. Also, be sure that the table selection has a T-rating* (refer section 4 for details) and meets other applicable standards for its operating environment.

Quantifying the Circuits

The maximum circuit length is the total length of cable that can be fed from a single power connection point, inclusive of all splices, including tees. The vendor catalogues provide the details of the applicable circuit length. Note that circuit lengths that are longer than these maximum lengths may require larger circuit breakers. The designer must be sure to check with the electrical engineer the available amperages of the branch circuit breakers supplying power to the heat tracing. After the required number of circuits is determined, the circuits are allocated to the power distribution system appropriately.

Further references: Pipe and Heat Tracing design considerations, heat loss calculations, installation and maintenance requirements are extensively covered by IEEE Standard 515-1997. Additional information and requirements are also published in NFPA National Electrical Code under Article 427.

SECTION – 4: SELECTION CRITERIA FOR TRACING SYSTEMS

Heat tracing is an energy intensive operation and shall be considered only if it is absolutely must and when all possible alternatives to avoid heat tracing are exhausted. Heat-tracing may be avoided in situations where heat loss to the environment can be effectively minimized. Three possible methods are:

1. Water pipes can be buried below the frost line. Alternatively, they may be kept from freezing by running indoors through heated buildings.
2. Water pipes can be designed for continuous circulation to allow flow all the times;
3. In cases where flow is intermittent, tracing might be avoided by designing a self draining system and the pipes may also be cleared after use by means of compressed air, steam, or solvent flushing or “pigging.”
4. Choose an air cooler instead of water cooled heat rejection options.

FACTORS AFFECTING THE SELECTING OF HEAT TRACING SOLUTION

Assuming that methods for avoiding the need for tracing have been considered, the plant must review and evaluate following factors to select the proper tracing system.

Process Evaluation

Two factors are important: 1) Start-up time; and 2) Process temperatures (maximum and minimum);

- **Start-up Time:** The highest energy demand occurs at start-up, and the time allowed for start-up will affect the steam flow requirements. The shorter the warm-up time allowed, the higher the steam flow requirements. Additionally, more heat transfer surface area or higher steam pressures could be required. It is important to work with the production team to evaluate the start-up requirements and to ensure you provide the proper heat tracing cable or proper heat transfer area for steam flow requirements.
- **Process temperature requirements:** The process temperatures will dictate the type of heat tracing cable or the steam pressures the plant.

Availability and Costs

The capital cost of electric heat tracing is high compared to steam but the installation of steam tracing is more labor-intensive ($\frac{1}{2}$ -in copper tubing is more difficult to install than the more flexible electric cable). In high-labor-cost areas, the expense of labor can easily offset the higher material cost of electric tracing. In addition, steam system is very expensive to maintain. Leakage or failure of the system is difficult to locate. Where failure does occur, it is frequently due to leakage at the wall of the core pipe allowing steam to pass into the process material and vice versa.

Hazard Classification

The heat tracing system must operate safely in a hazardous environment. Steam tracing system is inherently safe but the electrical tracing system must be classified according to National Electrical Code (NEC), which defines the hazardous areas in terms of - Class, Group and Division.

Class: Class is used to provide a general definition of the physical characteristics of the hazardous material with which we are dealing. The three classes are:

- Class I: Gasses, vapors and liquids that can be present in explosive or ignitable mixtures. For example: Gasoline - As a vapor (or liquid) is ignitable and/or explosive; therefore, it is a Class I material.
- Class II: Dust, Combustible dust that can be present in amounts that could produce potentially explosive mixtures, or dust of an electrically conductive nature. Examples: Flour or cornstarch. As a compact mass these products may only burn or smolder but when finely distributed in air. The mixture becomes explosive. Metallic dusts such as aluminum or magnesium have several dangerous properties. They are electrically conductive. They can burn very violently even when not finely distributed in air.
- Class III - Fibers or flyings that are easily ignitable but are not apt to be suspended in air in such amounts to produce ignitable mixtures. Example: Rayon, Nylon, Cotton, Sawdust or Wood Chips, etc.

Group: Group designations are used to selectively group the material by relatively similar hazardous characteristics. For Example: Both gasoline and hydrogen are

explosive when mixed with and ignited, but the explosive effect and violence of the resulting explosion will be substantially different.

Groups are designed by the letters A through G. A through D are Groups for Class I and E through G are Groups for Class II.

A, B, C, D - Gases/vapors are grouped by:

- Severity of explosion pressure expected.
- Extent of flame propagation between parts.

E, F, G, - Dusts are grouped by:

- Combustibility
- Penetrability between parts
- Ability to contribute to creation of an ignition source (abrasiveness, electrical conductivity).
- Blanketing effect
- Ignition temperatures
- Classification of Gases, Vapors and Dusts for Electrical Equipment

(NFPA-497M) can be used by authorities having jurisdiction as a guide for determining the Class and Group of a particular material. It includes materials classified by test and materials classified by analogy to tested materials. Authorities should consider verifying classifications by test if the material of concern has only been classified by analogy.

Division: The division indicates the likelihood of the presence of the hazardous condition under different conditions. Two Division classifications are utilized, Division 1 and Division 2.

- Class I, II, III, Division 2: Areas where explosive concentrations of vapors, dust, or fibers may be present in unusual circumstances. Special heat-tracing cables, usually equipped with a metal braid and an outer jacket shall be used in these areas.

- Class I, II, III, Division 1: Areas where explosive concentrations of vapors, dust, or fibers may be present in usual circumstances. Measures considerably more stringent than those taken for Division 2 are required in Division 1.

The NEC also stipulates that the temperature of the exposed surface of the (electric) equipment shall not be in excess of 80 percent of the ignition temperature of the combustible atmosphere. [Ignition temperature is a temperature at which material will ignite (independent of GROUP classification)]. Per the NEC, the temperature range marking is in the form of an Identification Number or T rating*

What is “T” Rating?

The T-rating is defined as the “Temperature Identification Number” in the NEC and as the “Temperature Class Number” in IEC standards.

The purpose of the T-rating is to ensure that electrical equipment does not exceed the auto-ignition temperature of flammables that might be present in a hazardous location. For example, if say hydrogen is present, then all equipment used must meet the “T6” rating. This means that any equipment that can generate a hotter surface temperature of greater than 185°F must not be used as this will then increase the likelihood of an explosion by igniting the hydrogen in the atmosphere. Refer table below for T-rating designations and associated temperatures.

Division T-rating	Temperature (°C/ °F)	Zone T-rating
T1	450/482	T1
T2	300/572	T2
T2A	280/536	T2
T2B	260/500	T2
T2C	230/446	T2
T2D	215/419	T2
T3	200/392	T3
T3A	180/356	T3
T3B	165/329	T3
T3C	160/320	T3
T4	135/275	T4
T4A	120/248	T4
T5	100/212	T5
T6	85/185	T6

Environmental Considerations

Environmental factors include whether the area is dry or wet, moderately or severely corrosive or noncorrosive, and whether the tracing will experience rough handling or mechanical abuse during installation, operation, or maintenance. These considerations are primarily related to the performance of electric heat tracers. Electric heaters exposed to any of the environmental stresses must be protected accordingly.

- A metal sheath of a material is able to withstand the corrosive agent for MI cable;
- A braided sheath is required for polymer-insulated types of heating cables for resistance to moisture and inorganic chemical agents;
- Fluoro-polymer type sheathed cable is required for resistance to organic chemicals;
- The heater must be rated to withstand anticipated maximum exposure temperatures.

Heater Reliability

Costs are important but savings in front-end costs may not be justified, if the failure of a tracing system incurs the far larger expense of disrupting a process which depends on maintaining an acceptable temperature in the traced piping or requires removal and replacement of the thermal insulation and tracing system.

Steam tracing systems have high maintenance costs, but system failure is generally not a concern.

The major cause of electric tracing system failure is compromised insulation. Zone heaters and self-regulating heaters have parallel circuits.

Failure of a single heating element does not bring down the entire system, and repairs can be made in the field. The series circuitry of MI and polymer-insulated cable allows no such flexibility. A single failure brings the entire system down and the fault is difficult to field-repair, requiring the services of a trained technician.

PROS & CONS

Factors Favoring Electric Tracing

- Electric heat output can be adjusted for very low freeze protection applications to very high process maintenance temperatures up to 932°F (500°C). Steam cannot be used safely at such extreme low and high temperatures;
- Short lengths of pipe or long pipelines in the range of 15 miles (25 kilometers) in length may be heated by the use of various types of heating cables or skin effect heat tracing systems;
- Electrical tracing is an option for non-metal and lined piping because of the ability to provide very low heat output;
- Electric tracing is easily controlled and therefore has the ability to maintain products within a narrow temperature range. This means much more efficient utilization of energy;
- Since electric tracing does not convey a fluid, there are no fittings or traps that may cause energy leaks or require routine maintenance. This translates into simplified installation and reduced operation and maintenance costs;
- Electric tracing has proven to be a reliable choice for process pipe and equipment heating. High industry standards and approval agency testing provides verification of fitness for the intended service;
- Electric tracing allows remote temperature control and monitoring. Its temperature controller can be connected to an Ethernet-capable intranet system for remote monitoring of the entire system.

Factors against Electric Tracing

- Electric tracing may cause electric shock, spark or ignite flammable substances. It is prohibited in many plants where flammable materials are present in the atmosphere;
- If electrical heat tracing is not carefully controlled, there is the possibility that the cable could overheat and damage the pipe or insulation. This also renders the tracing cable unusable and the entire cable needs to be replaced;

- Electric heat tracing often provides an unacceptably slow heat-up period for the resumption of flow after an emergency shutdown or a plant turnaround;
- Operation costs can be considerably high (in terms of Btus) when compared to steam especially when “flash” steam or waste heat is available. If a plant has a cogeneration facility, a cost difference will still exist but it will be much lower;
- Should be carefully accessed in areas where the reliability of power supply is questionable.

Factors Favoring Steam Tracing

- Steam is an excellent choice for start up situations following a plant turnaround or after an emergency shutdown because the highest rate of heat transfer occurs when the temperature difference between the steam tracing and the cooler piping or equipment is greatest. During heat-up, steam condenses fast, releasing a large amount of latent heat energy due to the big temperature difference between the cold piping and the steam tracer. As the process equipment warms up, the gradual decrease in temperature difference brings about a corresponding decrease in the rate of steam condensation until an equilibrium condition is finally reached. Pipelines that are intermittently used such as at tank terminals to transfer sulfur, asphalts or other heavy hydrocarbon materials rely on steam for quick heat up and temperature maintenance;
- Steam tracing is frequently chosen in plants where steam is a by-product of condensation (“flash” steam) or where steam is produced from waste heat utilization. In these cases, electricity will be much more costly than steam;
- Steam tracing is intrinsically safe and may be used in Division 1 (and Zone 0) hazardous areas where electric tracing circuits are severely restricted (or prohibited) for safety reasons;
- Condensate from steam tracing can be returned for reheat and use at the boiler because it is considered “clean condensate”.

Factors against Steam Tracing

- Steam tracing operate in the “free run” mode and is rarely controlled. It may typically deliver many times the volume of heat required to maintain required temperatures or simply protecting a pipeline from freezing;
- Steam tracing has the potential to develop leaks and for some process applications, cross contamination between the heating medium and the process fluid may be serious safety risk;
- Steam supply lines providing service to steam tracers and condensate return lines will lose a certain amount of steam energy even when covered with thermal insulation. Malfunctioning steam traps can contribute to steam energy loss of 3% to 10%;
- Steam tracers are generally limited to short runs of 100 to 200 ft and tracing long or multiple pipes with steam can significantly increase both tracing complexity and cost;
- Steam tracing is generally not recommended for use with non-metal piping as it may overheat and damage the line;
- Steam tracing has significantly less contact area between the steam tracer and the pipeline so heat transfer is compromised;
- Steam tracing does suffer from poor reliability due to its installation quality. Since tubing is most commonly available in rolls and during installation it must be straightened and bent to follow the pipe. This often results in air gaps between the tubing and pipe which reduces the heat transfer of the system;
- Steam tracing requires larger utilities infrastructure compared to electrical heat tracing. An economic analysis may be required to fully evaluate the two technologies for a given project.

These inherent disadvantages usually make electric tracing more cost-effective in overall energy utilization.

Conclusion

This was a very basic introduction to electric and steam based heat tracing system design. Although heat trace may appear relatively simple, there is a good deal of complexity to both the electric as well the steam tracing application. If the system is undersized, costs due to frozen pipes or high fluid viscosity can be overwhelming. If the system is oversized, money is wasted in the first cost and recurring energy costs every day. Some of the same problems can occur if the heat trace system is not properly controlled.

There are many technical issues and considerations which must be addressed in the design of any specific system. It is important to know that there is no one single heat tracing method that is best for every situation. In fact there can be situations where both electric and steam tracing methods may be used to economic advantage in an industrial plant. Heat trace design shall be better left to a qualified heat trace contractor.
