



**PDHonline Course M502 (8 PDH)**

---

## **Flying Windmill The Gyroplane Story**

*Instructor: Jeffrey Syken*

**2020**

**PDH Online | PDH Center**

5272 Meadow Estates Drive  
Fairfax, VA 22030-6658  
Phone: 703-988-0088  
[www.PDHonline.com](http://www.PDHonline.com)

An Approved Continuing Education Provider

# **Flying Windmill**

## ***The Gyroplane Story***



# Table of Contents

<u>Slide/s</u>	<u>Part</u>	<u>Description</u>
1	N/A	Title
2	N/A	Table of Contents
3~94	1	Exceeding the Grasp
95~207	2	A Brain Wave Airplane
208~272	3	Flying Craft of the Future
273~387	4	The Spaniard
388~438	5	The American Autogiro
439~558	6	Convertiplane
559~600	7	An On-Going Legacy

# Part 1

# Exceeding the Grasp

***“Ah, but a man’s reach should exceed his grasp, Or what’s a heaven for?”***

***Robert Browning, Poet (1812-1889)***

# **Airships of the Ancients**

***“Records of almost every ancient tribe will show among its traditions the legend of some member who achieved the miracle of flight, either through the use of wings or other devices more closely resembling modern airplanes. And the extraordinary part of it is that there are one or two instances, apparently well authenticated, which record flights that were actually successful. Leonardo da Vinci’s glider, designed in 1490, very possibly would have flown successfully, equipped with some source of power other than the human legs which were supposed to keep it moving through the air. Da Vinci was the originator of the parachute and his conception of that device, while not so efficient as the modern ‘chutes, undoubtedly would have operated successfully...”***

***Modern Mechanics, October 1930***

# **The Challenge of the Ether**





***Daedalus* and *Icarus* flew in borrowed feathers set in wax, got too near the sun in an ancient Greek fable concerning man and his aspirations**



**Kites, popular in *China* since 200 B.C., taught man much about heavier-than-air flight. The woodcut at left depicts an English kite-flying enthusiast ca. 1600.**

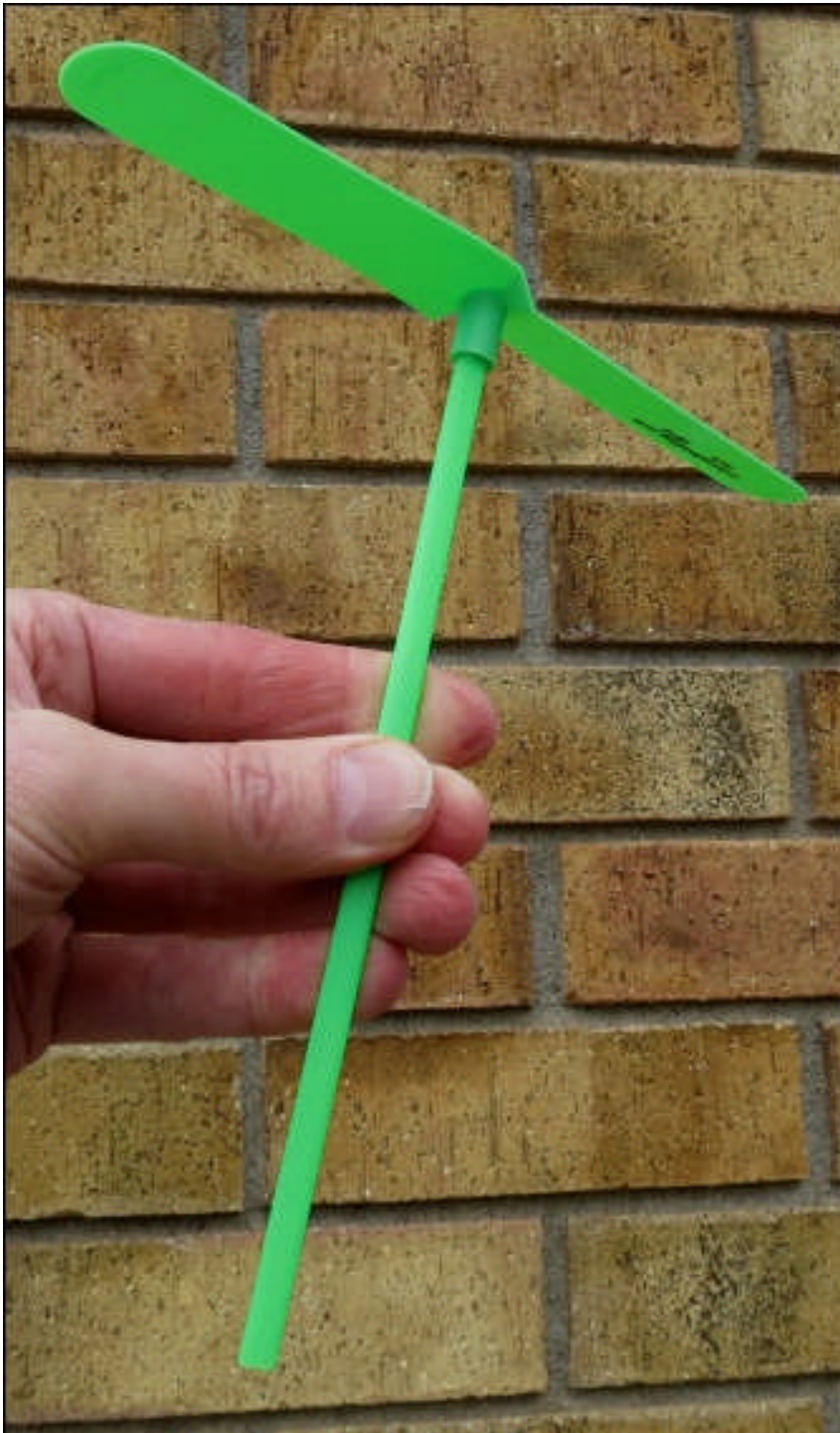

The basic idea of a helicopter - flight through rotating horizontal wings or “rotors” - goes back at least 1,500 years, through a simple invention known as the “Chinese Top” (left) that still survives today in various forms. This is a toy with a rotor blade mounted on a stick. Spinning the stick between the palms of the hands or by pulling a string wound around it causes it to soar into the air. The toy eventually made its way from *China* to *Europe*, where it appeared in paintings dating as far back as 1463. Not long after that, in 1483, *Leonardo da Vinci* illustrated a more sophisticated “rotary-wing” toy in his famous notebooks. However, building a rotary-wing aircraft that was anything more than a toy was beyond the technology of the era and remained so for centuries. 10

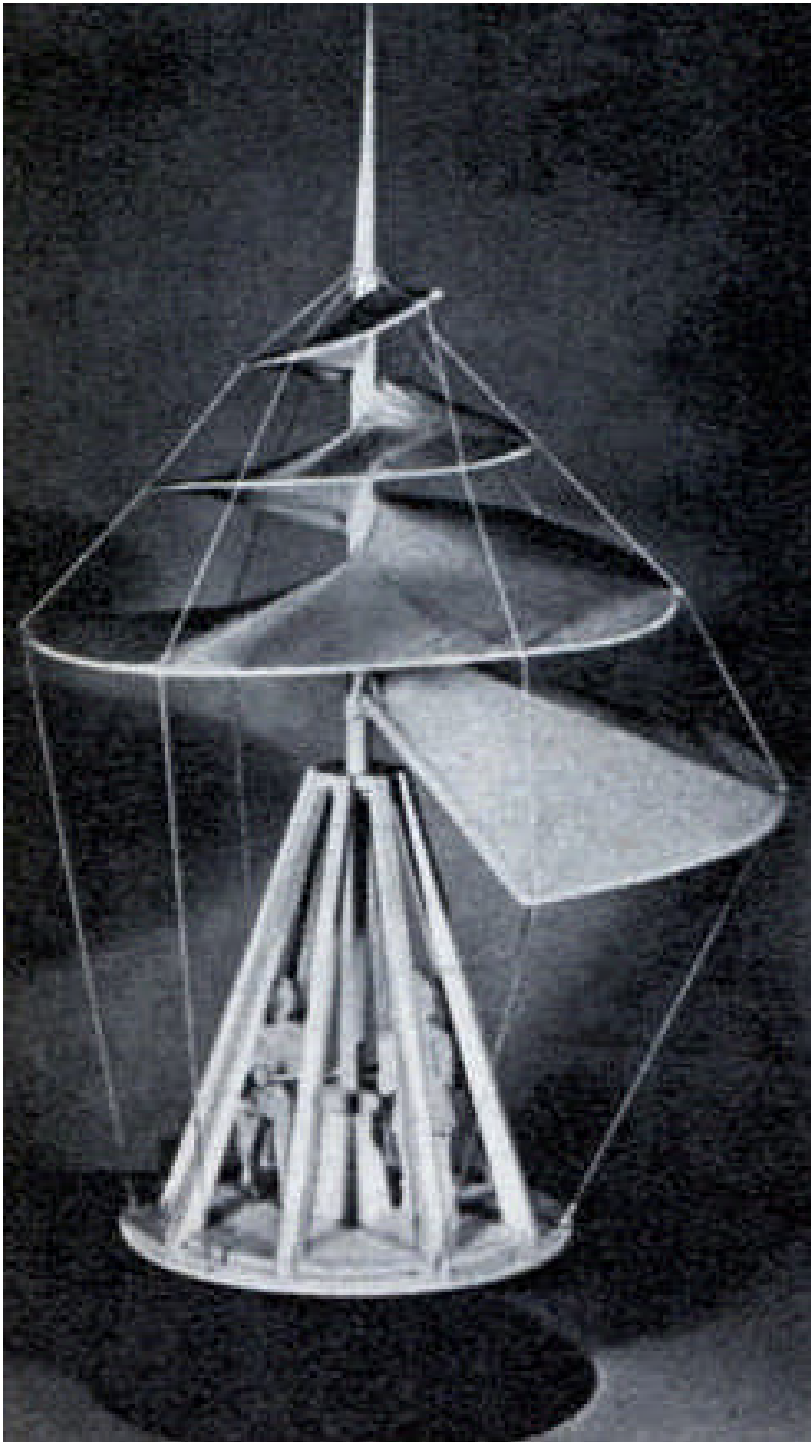

**Both the helicopter and propeller are suggested by Leonardo Da Vinci's flying screw concept (left). The genesis of the idea may have been the ancient "Chinese Top" toy.**



**Left:** copy of the original drawings and notes by *Leonardo da Vinci*. Between the mid 1700s until the early 1900s, quite a large number of designs and proposals were put forward for helicopters. The majority of these designs and proposals, some of which were very grandiose, never progressed beyond the initial concept. Additionally, because of the lack of an engine with a suitable power-to-weight ratio, all helicopters built (up until 1907) were essentially toys or large models which were not capable of lifting more than their own weight. Power was derived from a number of sources such as electric motors, clock-springs and elastic bands. In some cases, the rotors were turned by “steam-jets” at the end of each rotor blade. The first successful steam-driven model was built by an Englishman named Phillips in 1842. The model managed an uncontrolled flight across two fields. Launoy and Bienvenu based their idea on the *Chinese Top*, using four feathers for each rotor at either end of a short stick. The device was rotated by means of <sup>12</sup> a bow string.

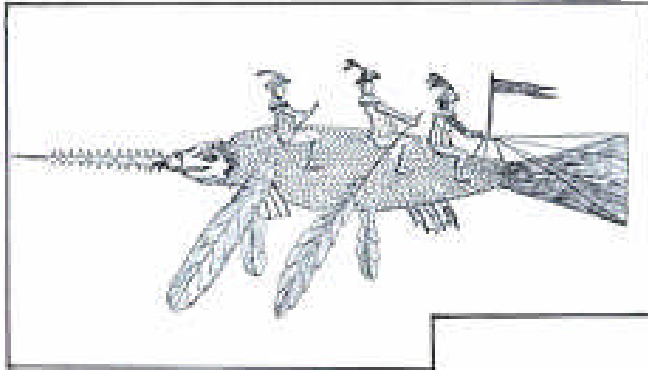

Above: caption: "Sketch of Airship devised in 1609 was a fish-shaped balloon inflated with hydrogen or hot air"

Right: caption: "Persian Flying Car, from drawing dated 1609"



***"In 1609 Pierre de Larrannes drew a picture of a flying fish airship of his own invention, reproduced in the sketch at left. His intention was to derive propelling force from two men who sat atop the fish and moved it forward by long, sweeping strokes with feather-tipped oars. A third man near the fish's tail was to act as helmsman, steering by means of a wheel which turned the rudder to right or left...Another ancient airship was the Persian flying car shown at left, supported and propelled by four birds, one at each corner. The***

***sketch is taken from a miniature and shows a Persian sportsman going hunting, back in 1600. He sits cross-legged on a cushion and leisurely fits an arrow to his bow as he descries flying game in the distance. Naturally this sketch is highly fanciful, but there were many similar ones during the period, testifying to man's age-old yearning to be able to fly. Geese, ducks and similar large birds were usually drafted into the medieval artist's pictorial conception of an airship, which rarely got beyond the stage of a drawing on paper. Needless to say, none of these contraptions ever got into the air, but it was out of such fancies as these that the airplane was finally developed."***

***Modern Mechanics, October 1930***

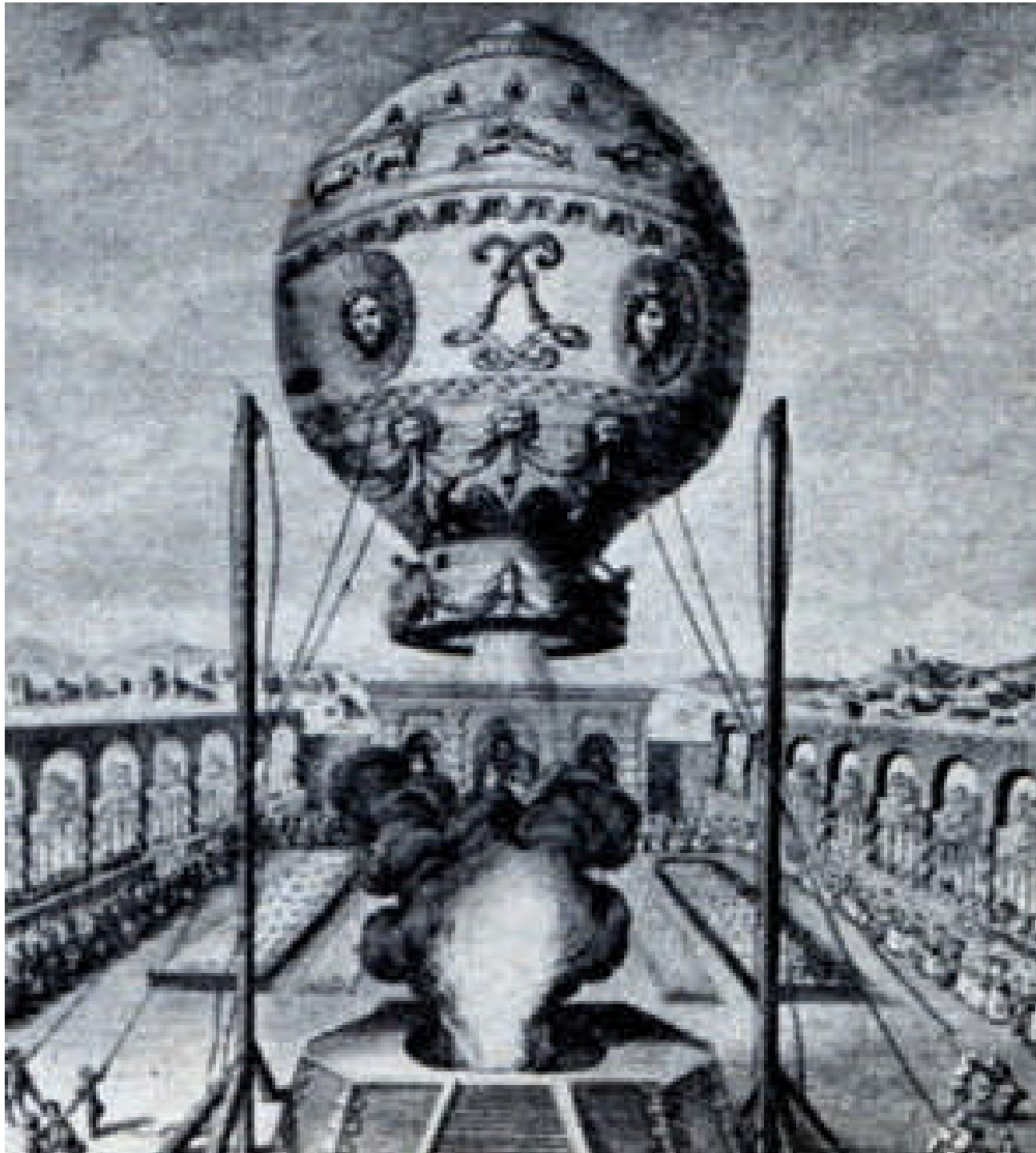

**The age of human flight began in *France* in 1783 with the Montgolfier Brother's first captive ascent in a hot air balloon. Free flight followed shortly thereafter.**



**The first balloon crossing of the *English Channel* took place in 1785. A wing-like propulsion system may have helped, but a favorable wind probably helped even more.**



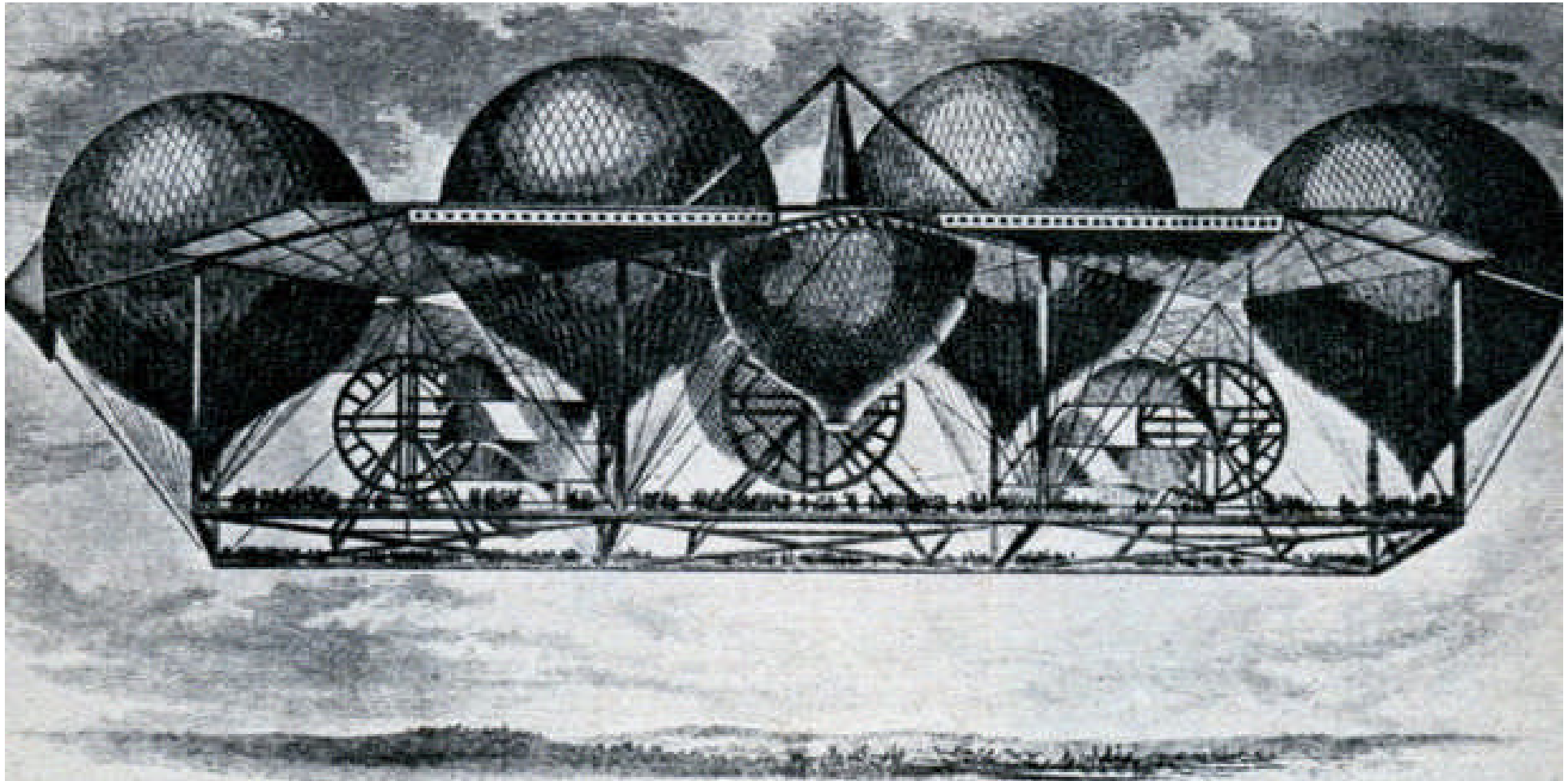

**Above: the dream ship of 1850 held four balloons in a rigid frame. Propulsion was to be achieved through three manually operated *Archimedean* screws. It was never realized.**

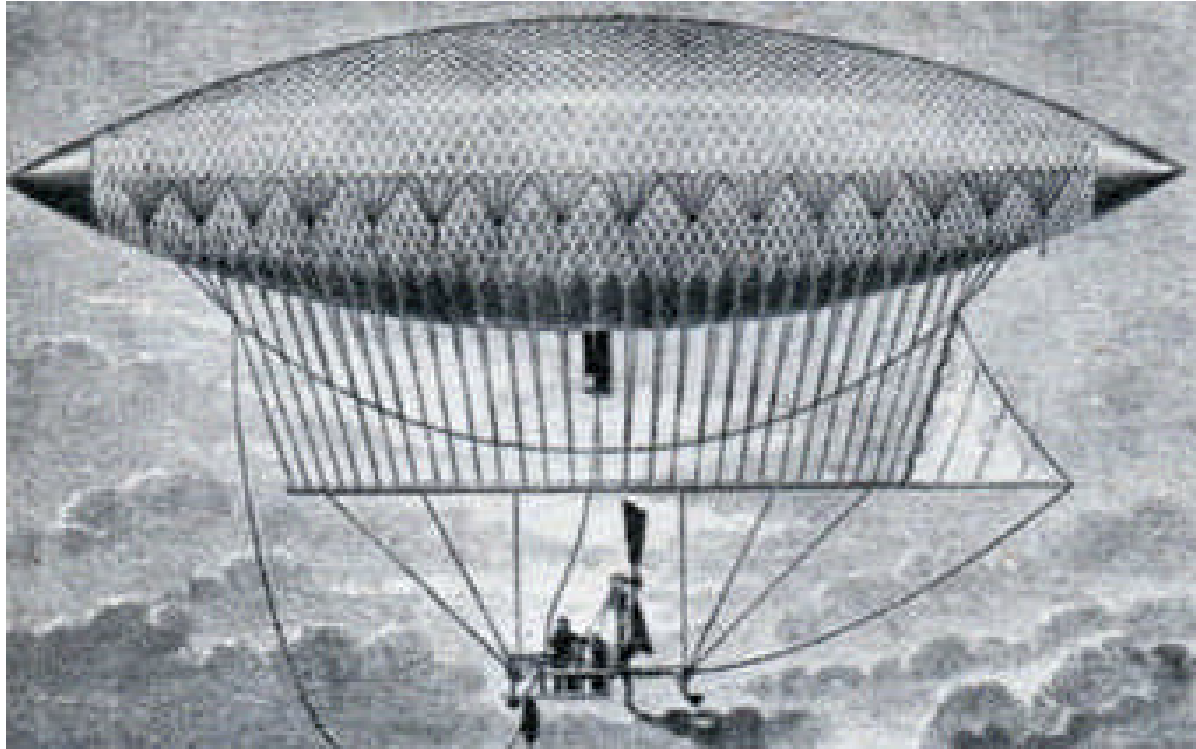

**The first steerable, powered airship (an elongated balloon) used a crude cloth rudder and, for propulsion, a propeller driven by a steam engine. It was flown by Frenchman *Henri Giffard* in 1852.**

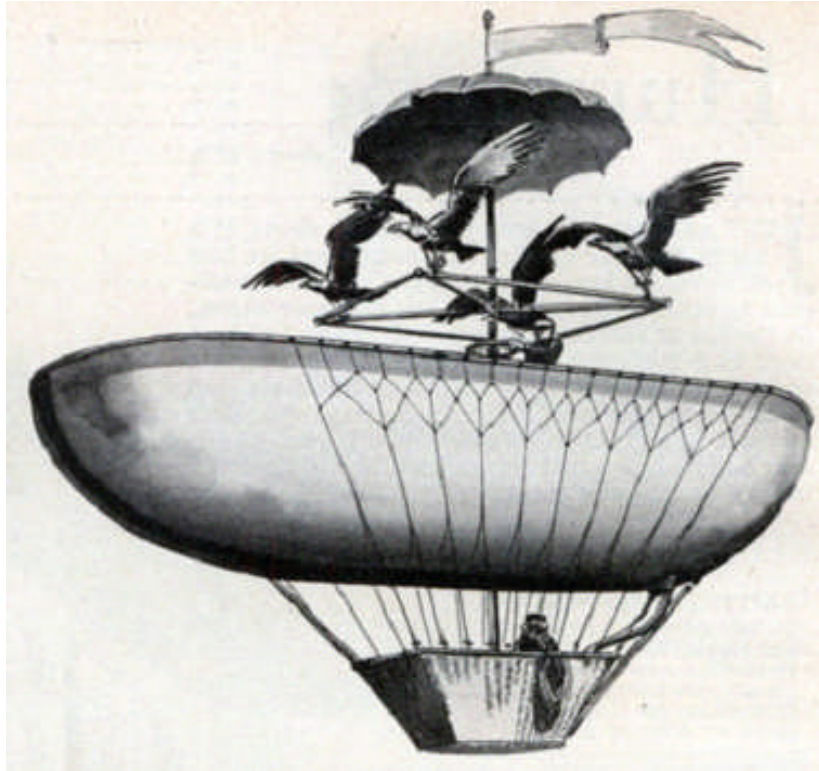

**Left: an attempt to utilize “living motors” is contained in a balloon patent issued in the *United States* in 1881 for a dirigible airship. By fitting large birds with corsets, the inventor planned to steer his dirigible through the sky. Eagles and/or vultures, wearing the makeshift harness (which left them free to flap their wings) were to be attached to a movable framework. By turning the framework, the airship would be piloted up, down, left or right (in theory, at least).**



**Left: the *Spheroid Dirigible* of 1887 had a central compartment for passengers with buoyancy chambers top and bottom. The engine was place in a hollow shaft in the center and connected to the pilot-house below.**

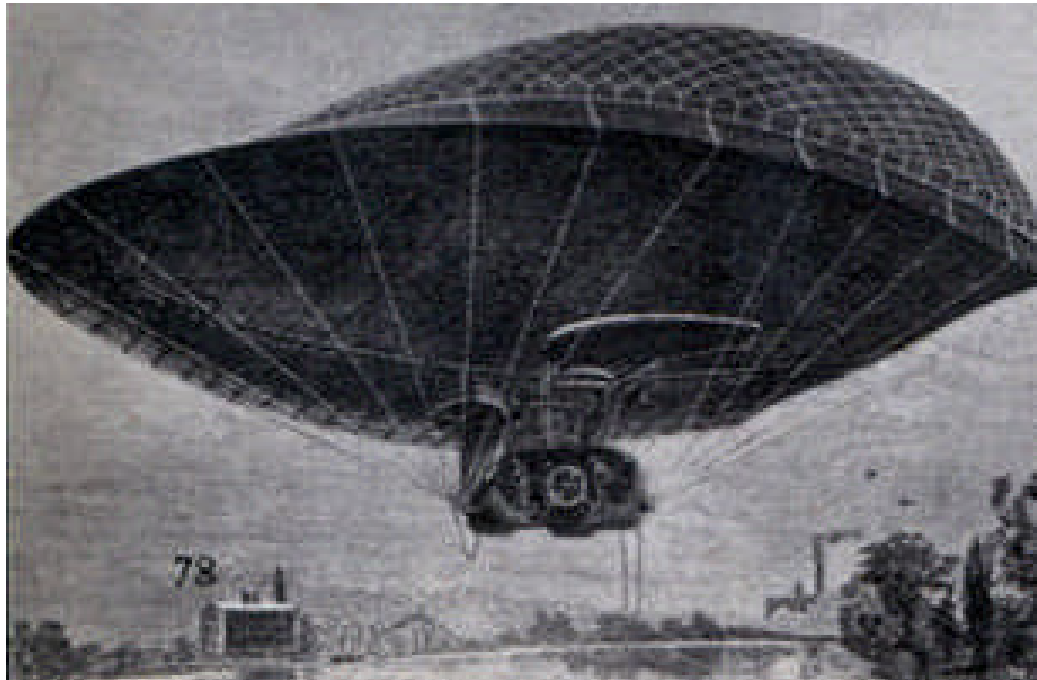

**Left: the *Bicycle Airship*—designed to fly in any direction – was the brain-child of *Herman Reickert* in 1889. The bicycle apparatus in the pilothouse flapped side and center wings, providing propulsion.**

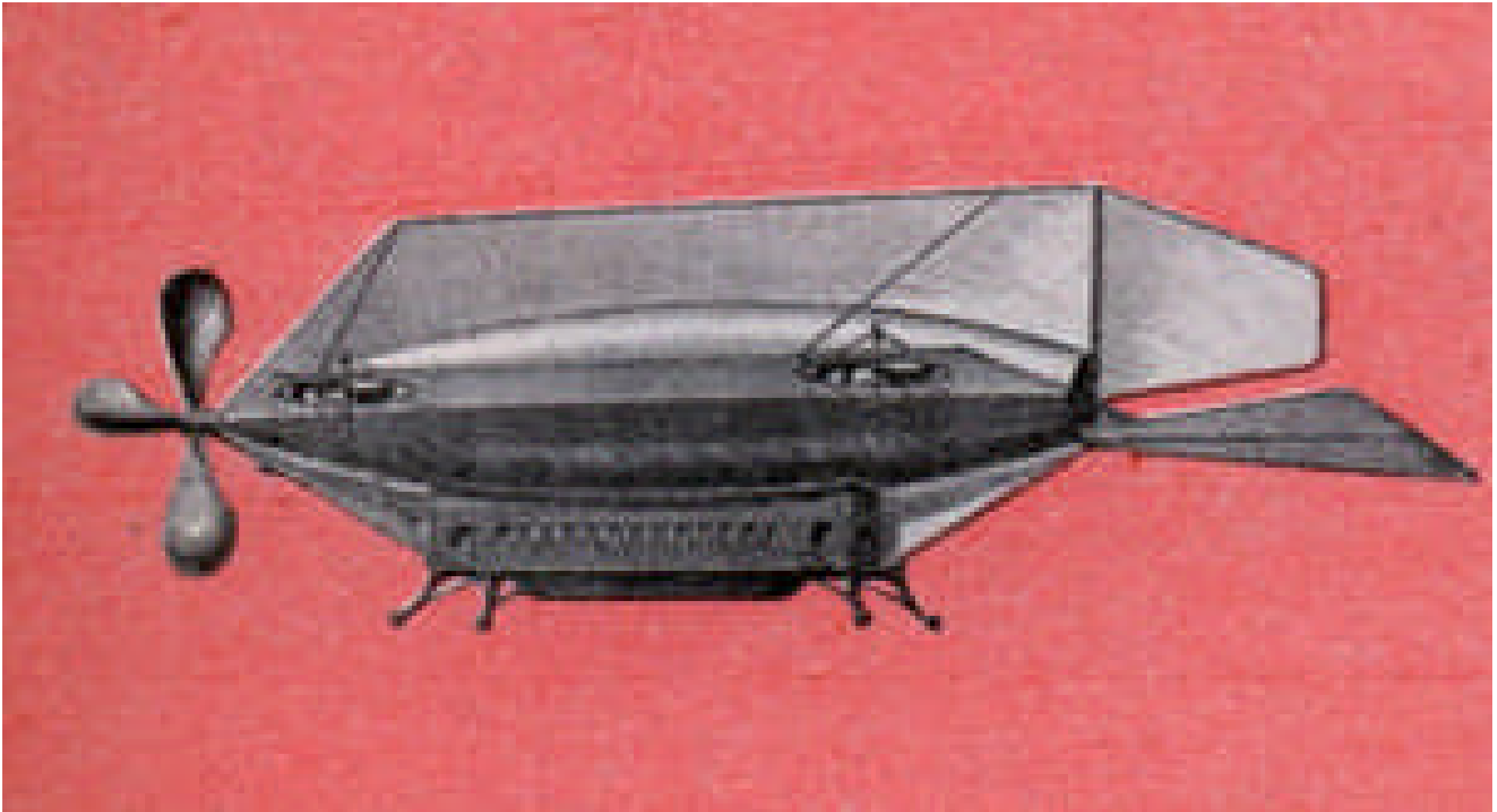

**Above: the *Pennington Aluminum Airship* of 1891 had a large sail over its gas bag which could be manipulated like that of a boat. It had a large propeller in front for propulsion as well as two smaller propellers, one on each side-wing.**

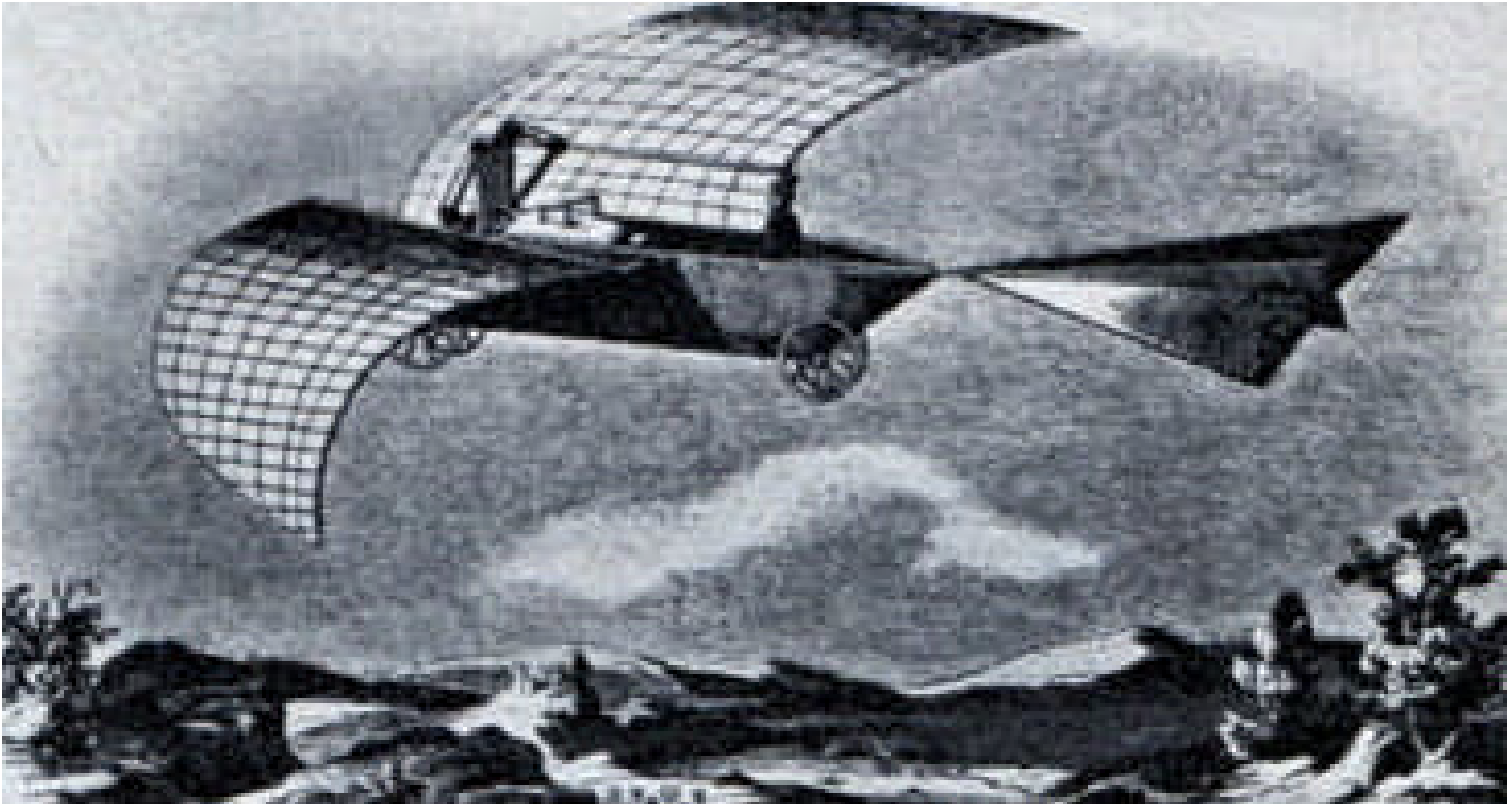

**Above: a *19th Century* magazine's concept of a heavier-than-air flying machine**

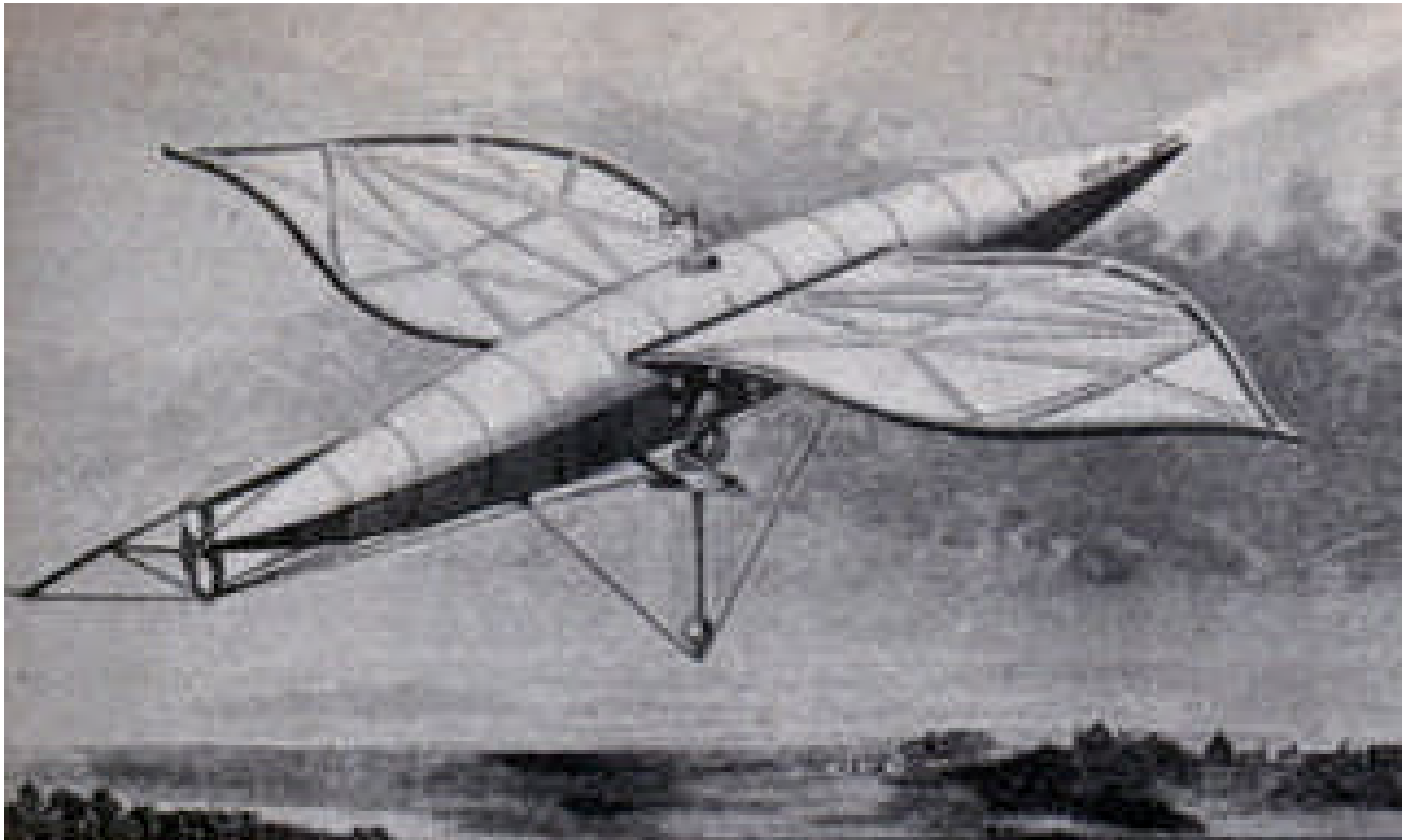

**Above: this steam-powered Russian flying machine of 1883 had a propeller in the rear and two great wings. Air entered through the nose of the craft to allow combustion of fuel (a pendulum provided equilibrium). Alas, it failed to take flight.**





**Above: travel by rocket is an old idea in the literature of speculation on human flight. This hardy rocketeer seems unconcerned about his comfort nor how exactly he's going to land safely.**

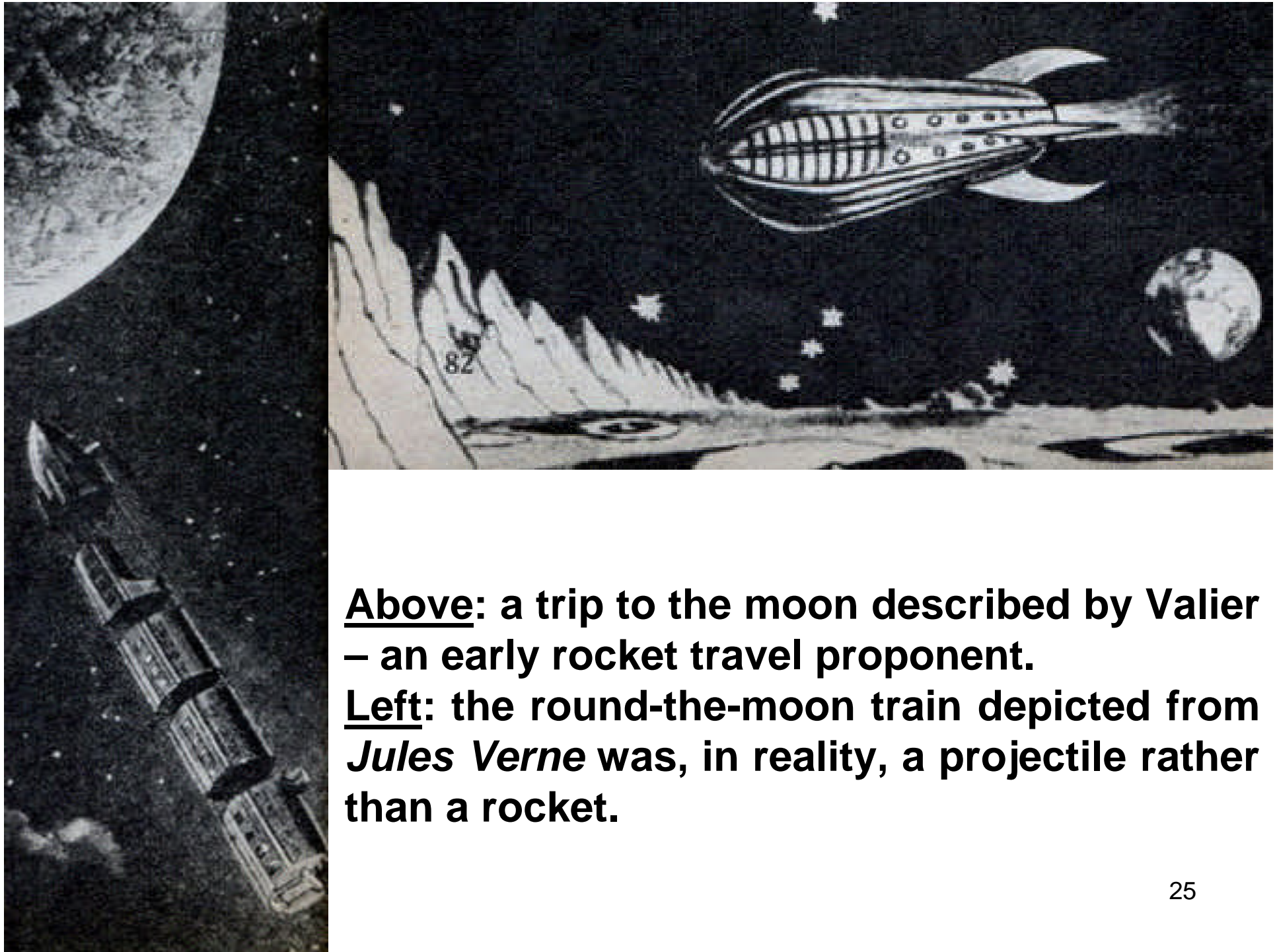

**Above: a trip to the moon described by Valier – an early rocket travel proponent.**  
**Left: the round-the-moon train depicted from *Jules Verne* was, in reality, a projectile rather than a rocket.**

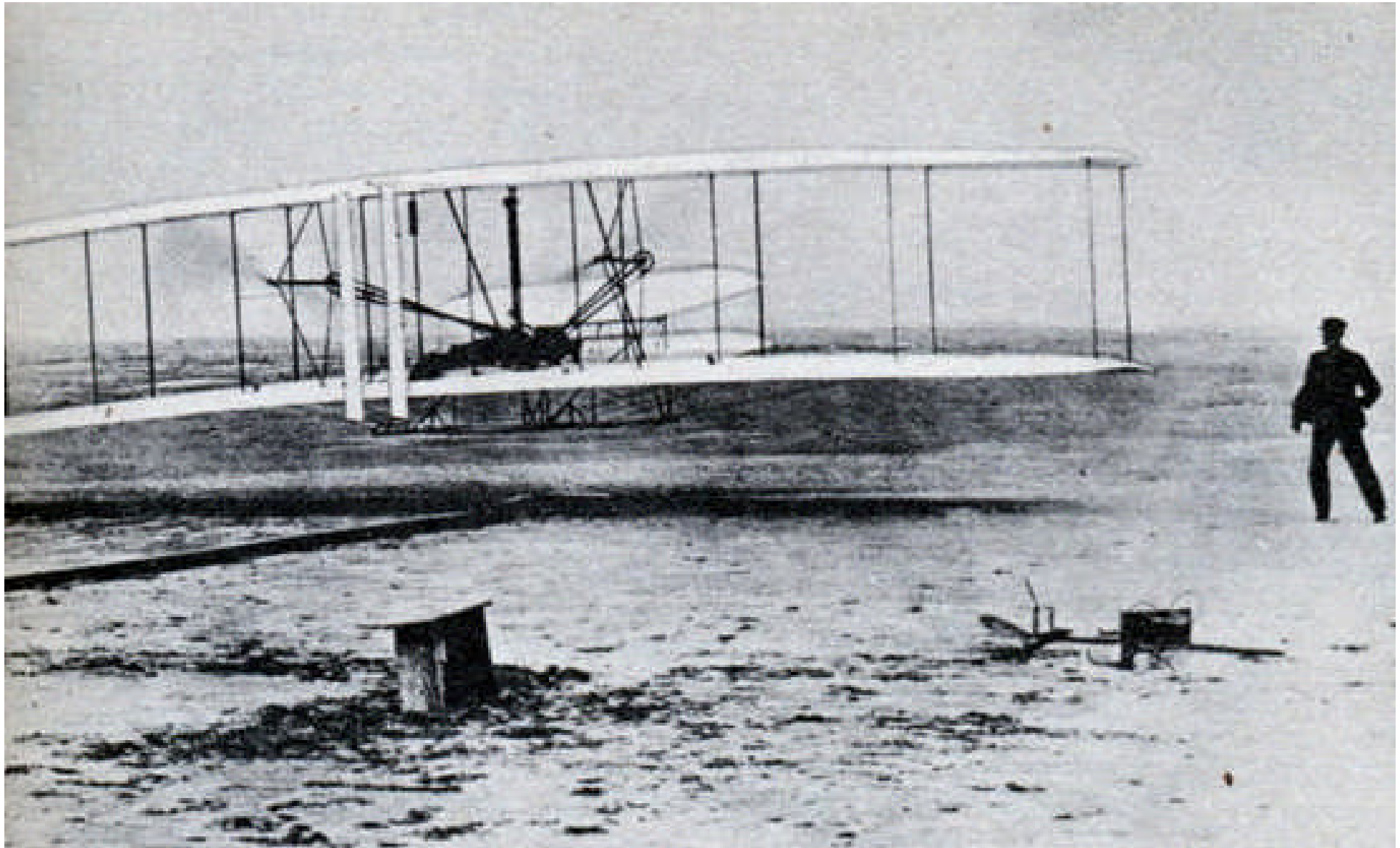

The Wright Brothers' great innovation was the *aileron* – the “little wing” that gave them control of their primitive airplane which was first flown at *Kitty Hawk, NC* in 1903

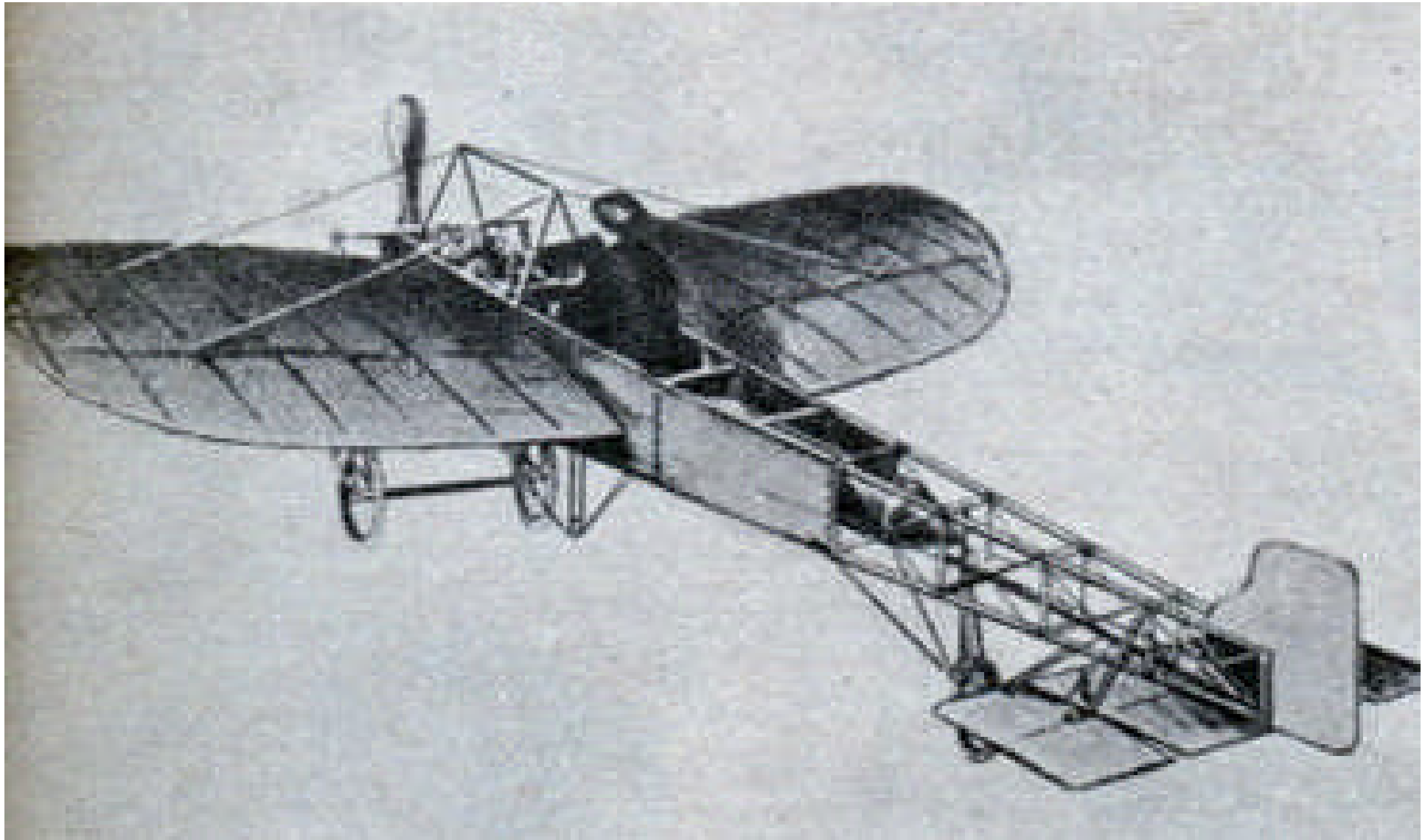

**Above: Louis Bleriot's wing-warping monplane was the first heavier-than-air machine to cross the *English Channel* (in 1909)**

# **Ornithopters & Orthopters**

***“...An ornithopter is a flapping wing machine supposed to be a mechanical copy of a bird’s wing, and an orthopter is a flapping wing machine which the inventor believes is an improvement on a bird. A famous aviation editor once described an ornithopter as the inventor’s idea of how a bird’s wing worked, and an orthopter as the designer’s idea of how a bird’s wing should work if the Creator had known anything about aerodynamics...”***

***Modern Mechanics, October 1930***

***“Built with flapping wings and bird-like body, this ‘American Eagle’ plane collapsed before its inventor could get the novel machine off the ground! The mystery attached to the so-called ‘mystery airplane’ built by James A. Crane of Ellsworth, Maine, seems to be – ‘Why doesn’t it fly?’ Built with flapping wings designed to lift it straight up into the air, the strange plane collapsed a few minutes after its motor was started up. The inventor, however, was undaunted. He expects to rebuild his plane, which he calls the ‘American Eagle,’ substituting metal wings for the wooden ones which the first test proved to be too flimsy. The cranking arrangement by which the wings were flapped is clearly shown in the above photographs.”***

***Modern Mechanics, January 1929***



**Above Right: caption: “Wheeling the plane out of the hangar for the trial flight”**

**Left: caption: “Just before the motor was ‘given the gun’ on the test”**



**Above: caption: “Shown above is all that was left of the novel bird-plane after it had shaken itself to pieces. The inventor expects to rebuild it, using stronger metal throughout to strengthen the construction”**

# **Why Wing-Flapping Planes Won't Fly**



***“The odd plane described here is just another manifestation of the wing-flapping idea which has cropped up periodically ever since man first considered the conquest of the air. There is a certain brand of inventor obsessed with the idea that the only satisfactory way to achieve flight is by a literal application of bird-flight principles. To this class of inventor all present day aircraft appear completely unsatisfactory particularly in their use of airscrews rather than wing beats as a means of propulsion. As a matter of fact, if the wing-flapping theory is tenable it would be just as logical to throw all modern boats into discard and replace them with ships driven with some sort of fin arrangement which followed closely the fish method of propulsion. It is true that the study of bird flight has been of great value in the development of human flight and it is probably equally true that man has still much to learn from this study, but the results of this study have shown, and possibly will continue to show, that the wing-flapping type of aircraft is not likely to be developed. Even a superficial study of birds shows that most of the larger species are primarily not wing flappers, but soarers, and it is from this latter class that most of the beneficial knowledge has been obtained and applied to airplane design. All attempts of inventors to produce a practical wing flapping craft have signally failed, but apparently this is a class not easily discouraged...”***

***Modern Mechanics, May 1932***

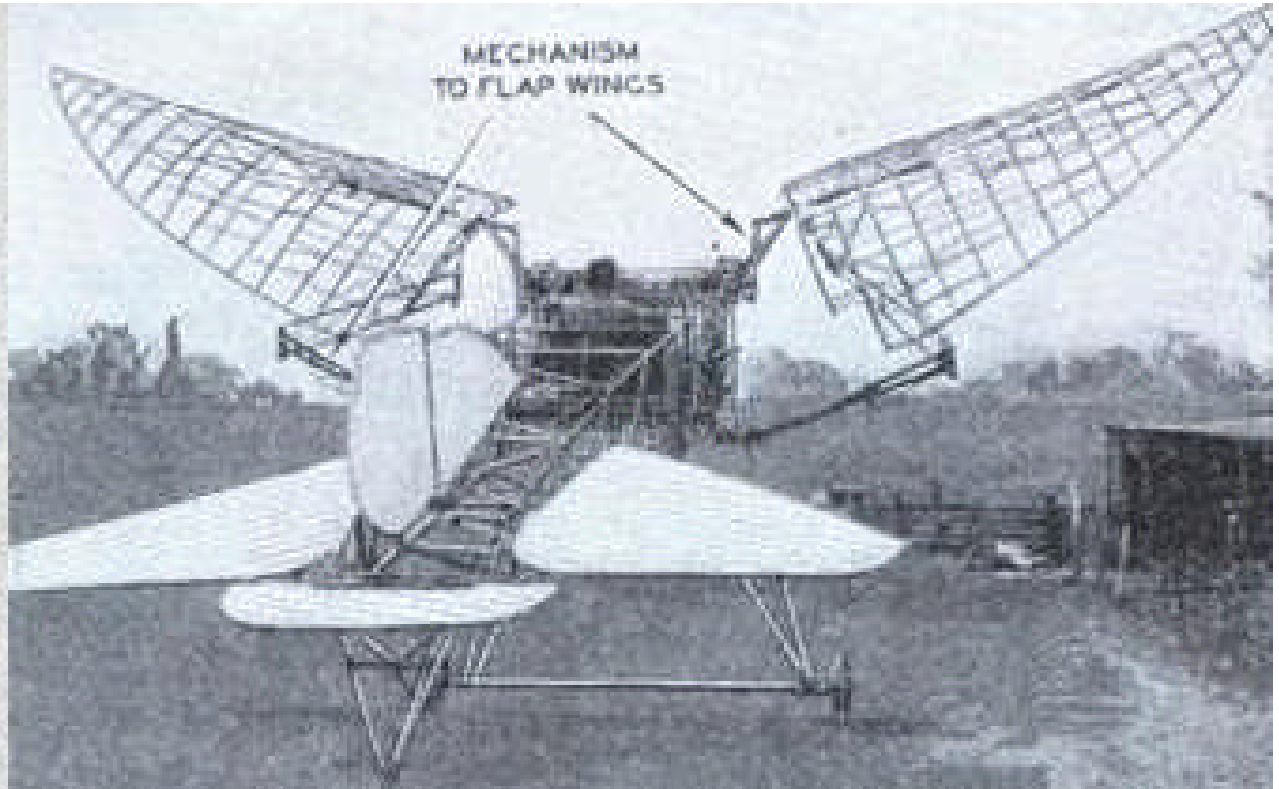
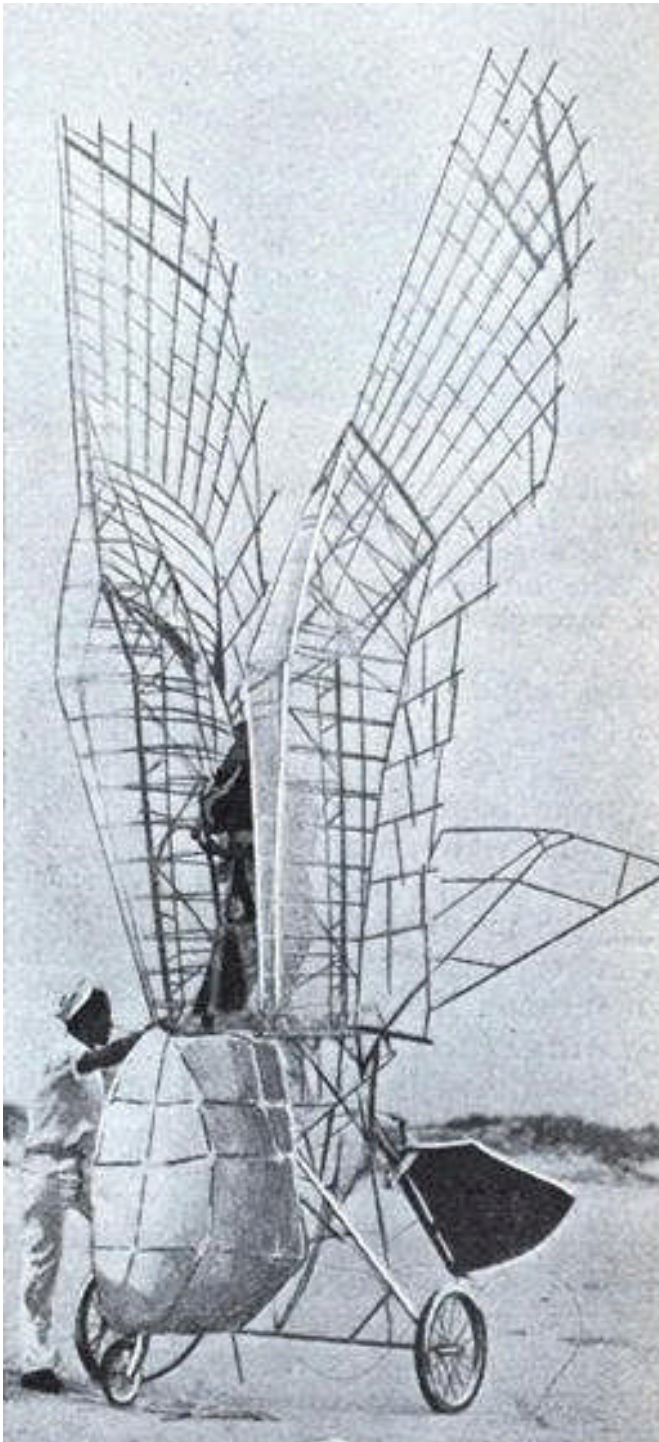

**Above: caption: “As the result of intensive study of the flights and structure of heavy birds, Robert Myers, of Rockford, Ill., has designed and built an ornithopter from which he expects to develop ideas for further experiments with such ships. The strange ship has wings crisscrossed with rib structure and hinged to the body in such a way that the wings can be flapped to propel it. Myers, like many before him, believes that it may be possible to learn secrets of flight from birds that will enable man to perfect highly developed flying wings; a type of aircraft radically different from the rigid type of winged ships now in use.” (*Modern Mechanics*, February 1930)**

**Left: caption: “No ornithopter or wing-flapping plane, like the one at left, has never made a successful flight” (*Modern Mechanics*, 33 May 1932)**



***“...An aircraft which combines features of balloon and airplane is pictured above, the invention of E. Winter, of Fareham, England. It is a glider-like machine fitted with flapping wings which are intended to give it forward motion. Lifting power is supplied by a tank of hydrogen. Thus far, it has not been tested successfully.”***

***Modern Mechanics, September 1929***

***Above: caption: “This queer machine is a flapping-wing glider, operated by foot power, which is expected to ascend by the buoyancy of its hydrogen filled tank, which is the triangular white object under pilot’s seat”***



***“With only a pair of strange cloth-covered wings strapped over his arms, Joe Fodie of Rowena, Oregon, hopes to glide through space by the power of his arms alone, after jumping from a mountain top precipice. Should this intrepid inventor glide safely to earth, it will be the first time man has flown through the air under his own power. The queer wings are hinged at their center, with a stop to prevent them from buckling upward. As the arms are moved upward in flight, the outer halves of the wings would naturally fold inward; on the downward stroke they flatten out again, providing lifting power. Fodie designed his wing action to resemble as closely as possible the flapping motion characteristic of a bird in flight.”***

***Modern Mechanix, February 1935***

# **The Austrian Wing-Flapping Aircraft Company**

***“...One of the more promising developments in this line of aircraft is now being completed in Austria. The inventor, Carl Czerny, produced several working models before the war and was working on a full size experimental ship at the time of his death. The results obtained from this plane encouraged the formation of the Austrian Wing-Flapping Aircraft Co., which is now engaged in continuing Czerny’s experiments. The Czerny plane shows evidence of a serious and carefully thought out plan to utilize wing beats not only as a means of forward propulsion but also as a means of controlling stability, steering, ascent and descent. Realizing that the larger birds, particularly the soarers, do not derive their lift and forward motion by employing action of the entire wing but maintain a constant and sometimes almost imperceptible motion of the outer wing, Czerny embodied this principle in his design. Consequently it is only the tips of the wings that flap on the Czerny plane - the main wing being a fixed surface similar to that found on conventional planes. Moreover there is an attempt to utilize the air pressure itself to assist the flapping action and thereby dispense with the excessive horsepower usually required to move the wings. A 3 1/2 horsepower motor on the experimental plane proved sufficient to flap the wings and with only two ‘feathers’ in place on each wing it is claimed that the plane lifted from the ground...”***

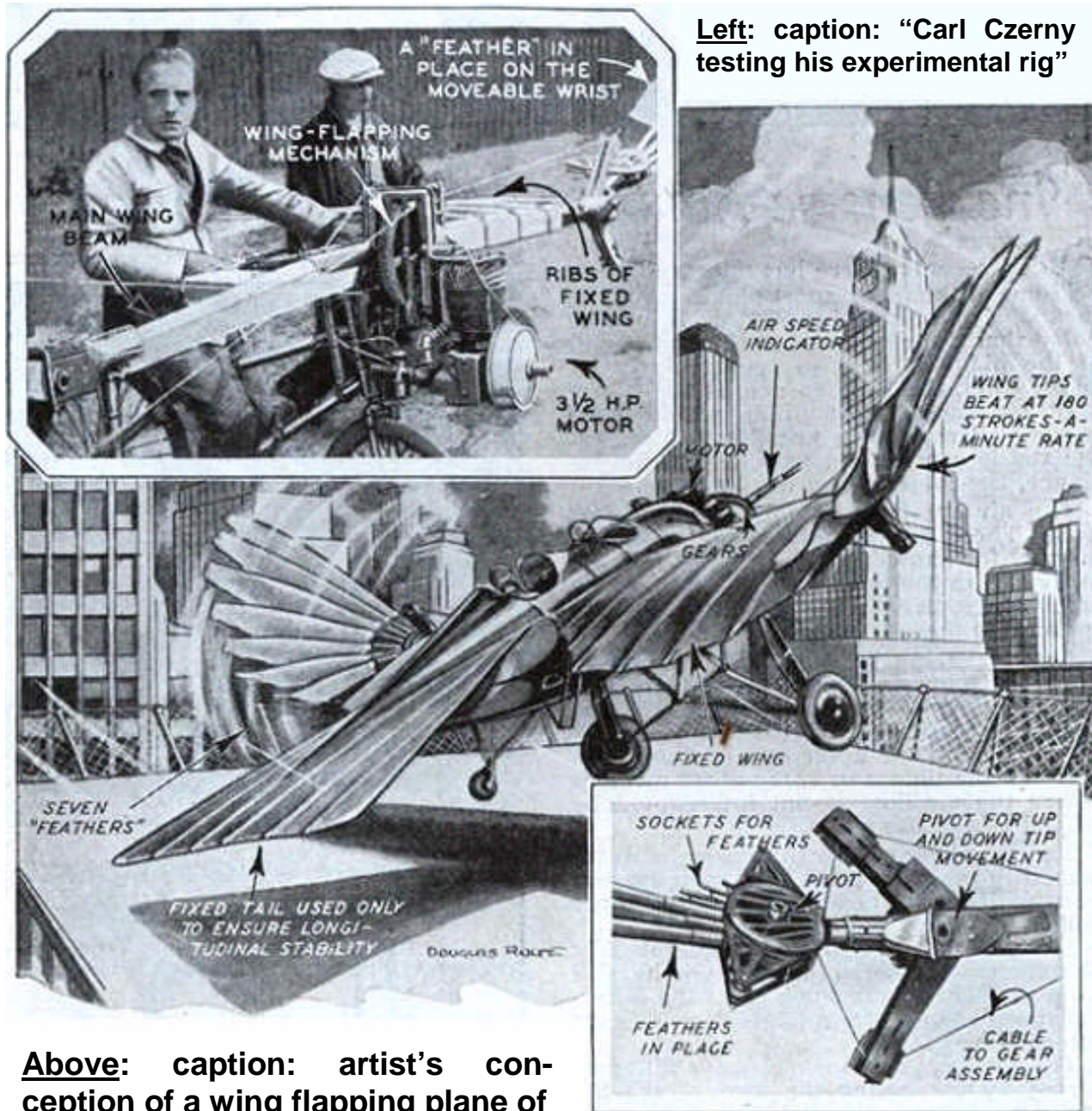

**Left:** caption: "Carl Czerny testing his experimental rig"

**Above:** caption: artist's conception of a wing flapping plane of the type described. At lower right is a photograph of the 'wrist' or link which connects the moveable and fixed wings. It is this 'wrist' which impares a rowing motion."

*"...Briefly described, the Czerny plane resembles a normal ship in general appearance with the startling exception that it has neither propeller nor vertical rudder. The main plane has at each tip a peculiar wrist-like device in which are mounted, fan-wise, seven flexible single spar wings or 'feathers,' the longest of which is about 6 feet long. These 'feathers,' being quite flexible, automatically adjust themselves to air conditions, and the motion of the wing. This quality, combined with the peculiar action of the 'wrist,' enables the wings to be flapped and moved in a rowing motion without the use of excessive power. The general action of the wings in flight is a flapping, rowing motion but either action can be used at the discretion of the pilot. That is to say, if for instance the plane has to be landed in a small space, the pilot can control the wing beats so as to curtail the propelling action and increase the up and down flapping to land in much the same manner as a bird. This wing action is connected to the motor through the 'wrists' by cables and gears. The 'wrists' themselves are the secret of the inventor and no information is available on how the action is obtained. The pilot can similarly control the wing action to take care of steering and maintaining lateral balance. The fixed tail is not controllable."*

38  
*Modern Mechanics, May 1932*

# **A Queer-Shaped Aircraft**



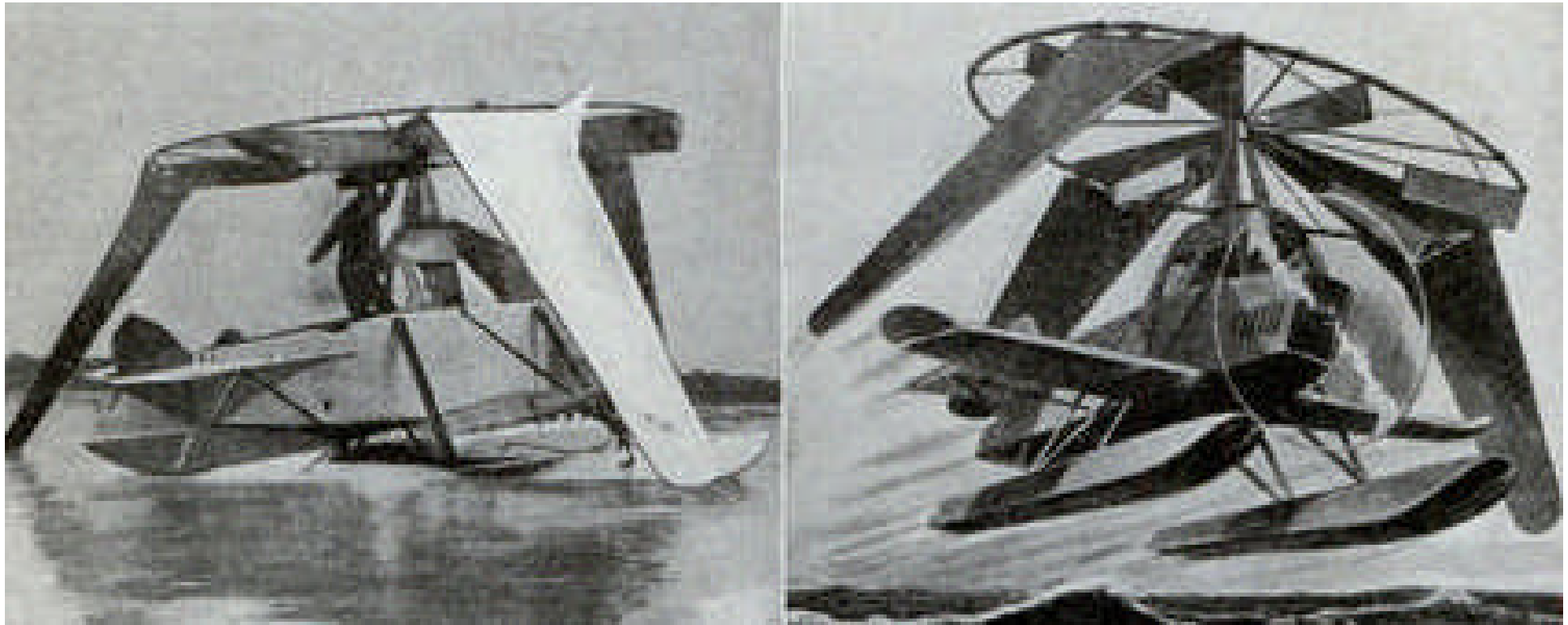

***“A queer-shaped aircraft, seemingly a combination of everything which has ever flown through the air, has proven successful in initial tests, doing just about anything in the way of performance that could be asked of a heavier-than-air craft. Jette, designer, a young Swedish engineer of Stockholm, believes his radically-designed plane will revolutionize the aviation industry. Stubby wings like those of the earlier autogyros give the plane stability in horizontal flight. The engine drives a propeller mounted forward as in the ordinary land plane, and through gears turns the huge overhead rotor. Three flapping wings attached to the rotor move up and down as they spin, just as in an autogyro, and vanes on the inside of the rotor provide lifting force.”***

***Modern Mechanix, February 1934***

***Above: caption: “Seaplane, autogyro, helicopter – whatever it is called, this strange craft can rise straight up in the air, fly in level flight like an ordinary plane, and take off or land on water. Right: Artist’s sketch of take-off as seaplane on water.”***

# **The Rotor Airship**

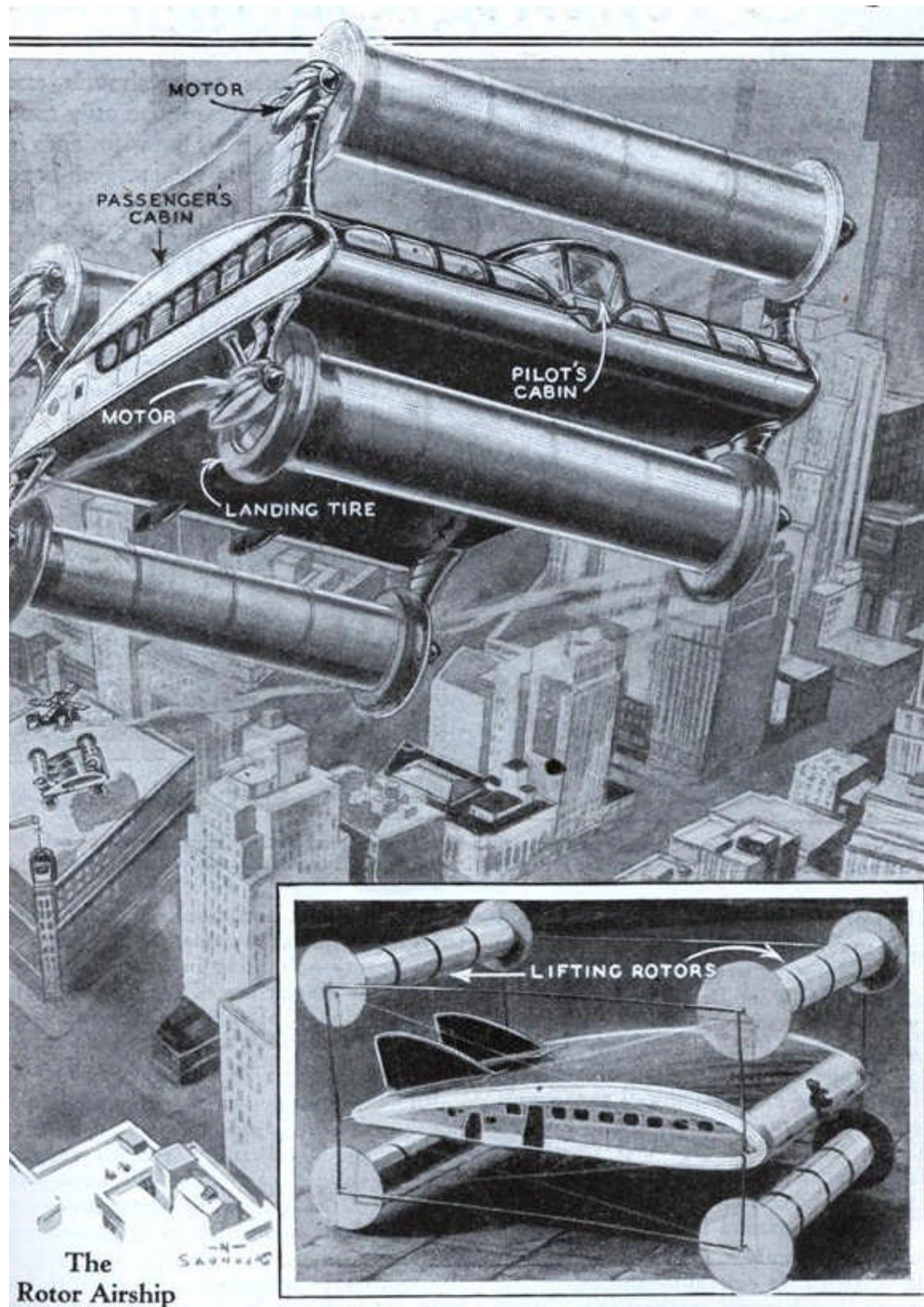

The Rotor Airship

***“The oddest contraption which has been brought to our attention this month is the rotor airplane designed by Ernst Zeuzem, of Frankfort-on-Main, Germany. The inventor’s model is shown in the inset, while above is an artist’s conception of how the full-size plane would appear in the air. Each of the four rotors will be driven by separate motors which need not be of exceptional power. The passengers will be carried in the wing section. In spite of its odd design, the principles of this plane are sound.”***

***Modern Mechanics, February 1931***

# Lighter-Than-Air Hybrids

***“...An idea which has intrigued a multitude of inventors, and which is not at all impractical, is a combination of airplane and dirigible, using gas to provide a lift equivalent to a part of the weight of the plane, and the wings to provide the additional lift. Such a combination, if it proves practical, would lessen the danger of accident by stretching the gliding angle of the ship to perhaps twice its normal reach...”***

***Modern Mechanics, October 1930***



**Above: caption: “In the circle, a conventional cabin plane is fitted with a gas bag to improve its lifting qualities. Also shown is Mr. Claude H. Freese, of Los Angeles, with his model of a dirigible equipped with airplane wings.”**

***“...Some inventors have proposed utilizing the thick wing of a monoplane as a gas cell, but a simple calculation shows that any possible degree of lift attained from the amount of gas which could be stored in a wing is extremely small. Pure hydrogen weighs 5 pounds per thousand cubic feet, and air at sea level density weighs about 80 pounds, so that 1,000 cubic feet of chemically pure hydrogen would have a lifting effect in air at sea level of 75 pounds. But pure hydrogen is impractical in commercial quantities, and the hydrogen used in airships has a lift of about 70 pounds per thousand cubic feet. Helium has a lift of from 60 to 64 pounds per thousand cubic feet. Assuming hydrogen is used, an average monoplane wing would not have space for more than 350 to 400 cubic feet, at the most, in fact the great majority could not contain more than 150 to 200, so the lifting effect attained would be almost nil. There is no reason for believing that a lifting gas superior to hydrogen will ever be found, but even if such a gas should be discovered, no gas could be superior to a perfect vacuum, which would weigh nothing, and, with the difference in weight between air at sea level and a perfect vacuum being but 80 pounds, that is the absolute maximum which might be attained, and only 5 pounds per thousand cubic feet better than pure hydrogen. If a plane and an airship are combined it therefore follows that the gas bag must be on the exterior of the ship...”***

***Modern Mechanics, October 1930***



***“...Taking the Stinson Detrouiter, six place cabin monoplane as an example of a type which might be combined with lifting gas, something of the following sort might be worked out: The Detrouiter, with Wright J-6 300 h. p. engine, weighs 2,614 pounds empty and 4,300 with fuel and pay load. Assuming a cigar shaped, metal gas bag, built after the plan of the Navy’s all metal dirigible, could be attached above the wing and fuselage, with a cubic capacity equal to one-half the weight of the ship, and that the combined weight of the ship and gas bag would be held to 5,000 pounds, then a gas bag of 35,714 cubic feet capacity would be needed, as that amount of commercial hydrogen would have a lift of 2,500 pounds. A bag of 35,714 cubic feet capacity would be equivalent to one ten feet square and 35.7 feet long. Because of the head resistance which the bag would offer to the wind its diameter should be kept as small as possible. Assuming the greatest diameter of the stream-lined metal gas container to be 12 feet, its length probably would approximate 50 feet. The length can vary greatly depending on the stream-line shape...”***

***Modern Mechanics, October 1930***

***Above: the Stinson Detrouiter***

***“...Of course in combining a gas bag and a plane the plane itself might be radically changed. The tail would offer the biggest problem. Airplanes can bank sharply, perform aerobatics, and be maneuvered easily because the tail surfaces are placed in the slip stream. An airship, with its rudders and elevators mounted along the tail of the gas bag, and traveling at much slower speed, is slow to respond to the controls and can cut only the widest of circles. The combination ship, because of the resistance of the bag, would be slow on the controls, which is no drawback for straight commercial flying. It is possible, therefore, that the fuselage tail might be curved upward to fit under the bag, or left off entirely, and the control surfaces mounted on the bag. Another suggestion that has been made is a standard plane with a fabric bag carried in a pocket along the top of the fuselage, to be inflated from gas cylinders in the cabin in emergency, just as an airplane parachute would be released under the same circumstances. The theory is that a parachute large enough to lower the plane stops forward movement, and therefore makes it impossible to pick a landing spot, while a stream-lined gas bag, inflated above the ship, would still enable the pilot to glide and pick his own field. The trouble is that the weight of gas cylinders would be excessive. The standard large size hydrogen cylinder weighs. 135 pounds, and contains 191 cubic feet of gas, compressed at 2,000 pounds pressure. It would take 181 such tanks, weighing more than twelve and a half tons, to furnish enough gas to give a 2,500 pound lift...”***

***Modern Mechanics, October 1930***



***“...The *Detroiter*, which has a wing spread of 47 feet 1 inch and stands 8 feet 11 ½ inches high, has a length of 32 feet 8 inches. A gas bag 50 feet long therefore would exceed the present airplane length by 17 feet 4 inches. The nose, however, could project beyond the propeller, and the small tail, being several feet above the tail, could project to the rear, so that would offer no particular problem. The finished ship, because of the lifting effect of the gas, would have an apparent weight of but 2,500 pounds against 4,300 for the standard plane, so less power would be required to move the weight. But the air resistance of the bag would be so great that it is probable considerable more power would be required to move the combination. The J-6 motor of 300 h.p. weighs 530 pounds, and the new 500 h.p. Cyclone weighs approximately 620 pounds. Therefore the more powerful engine, with 200 extra horse power, could be substituted to get the power to move the ship off the ground. Once in the air, with only 2,500 pounds plus the head resistance of the bag to move, the engine could be throttled down to save gas. In event of engine failure the wing spread of a 4,300 pound ship -would be available to land one with an apparent weight of only 2,500 pounds, which would mean a much longer glide, and therefore a much higher degree of safety...”***

***Modern Mechanics, October 1930***

***“...Dozens of inventors are working on the problem of combining the lifting effect of gas with the lifting power of a moving wing. The figures quoted in this article would indicate that if a successful solution is found it will be a combination in which not more than half of the entire load will be supported by gas, for beyond that figure the size of the gas bag and its head resistance become prohibitive to speed and maneuverability, the two points which have made the airplane successful. The successful ship, if it is produced, may not be anything like the one suggested. It may have the wings mounted from the sides of the gas bag instead of below it, and the power plant and propeller may be in the nose of the bag, or divided into a twin engine installation carried in nacelles slung beneath the wings. The latter idea has its advantages in maneuvering, for one engine can be retarded and the other sped up to make quicker turns. Also one engine would keep the ship afloat, with half the load supported by gas. Anyway, it is an interesting problem, and the activity of various inventors indicate it may soon be tackled in earnest, and perhaps solved. For it is a fairly safe bet that the airplane as at present developed is far from being the last word in heavier-than-air navigation...”***

***Modern Mechanics, October 1930***

# **The Gyro-Airship**

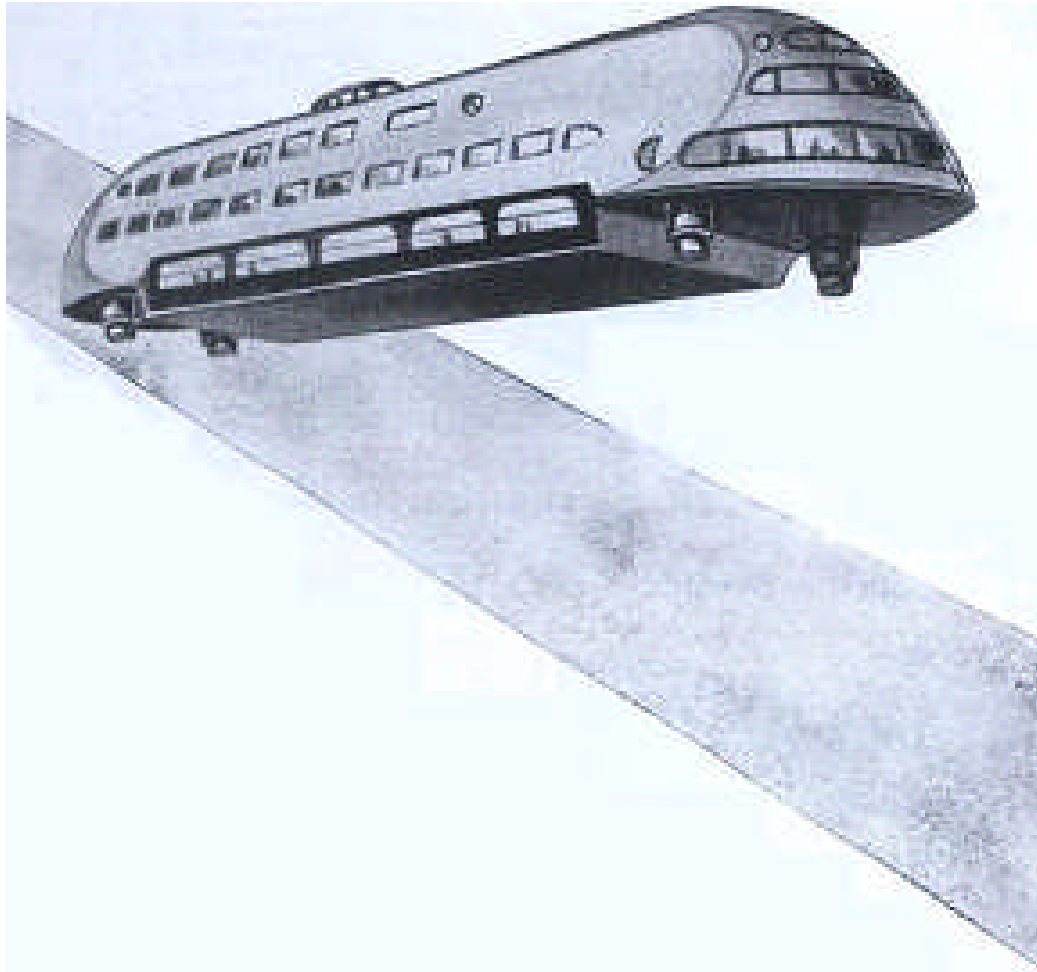

***“How does this airship keep aloft with neither propellers nor lifting gas? It’s the strangest craft yet designed to cruise the skies and represents as far a departure from conventional types of air-craft as can be imagined. You’ll find this description of the ship fascinating.”***

***Modern Mechanics, January 1931***

***Left: caption: “Looking like an immense Zeppelin hangar floating in the sky, the gyro-airship, with an immense load-carrying capacity and tremendous speed, bids fair to put railroads out of business as freight-carriers if the hopes of its inventor are justified.”***

***“...What is certainly the most unique airship in the world is now under construction in the form of an experimental model in the factory of its inventor in Denver, Colorado. As depicted on these pages, the extraordinary ship will use neither propellers nor gas to keep it in the air, but will depend on a mechanism which its inventor, Edgar R. Holmes, calls the ‘gyradoscope.’ Each horse-power of gyradoscope is expected to lift 1,000 pounds vertically in midair and sustain the load at any desired elevation by regulating the speed, and the inventor expects a machine weighing 2,000 pounds to lift 500 tons...”***

***Modern Mechanics, January 1931***

**Below:** caption: “A picturization of the principle by which a moving weight, as in the gyroscope, can be made to exert a lifting force”

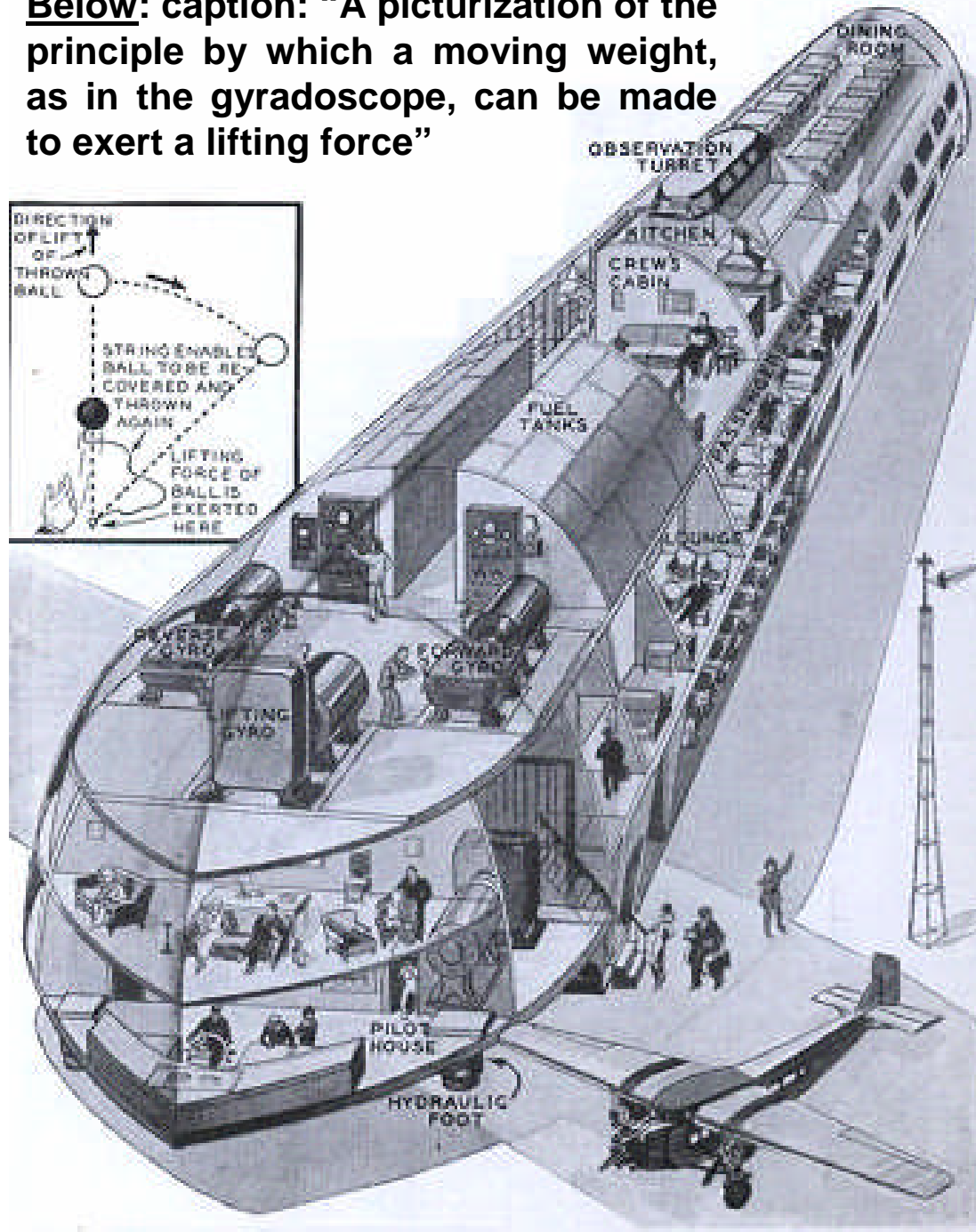
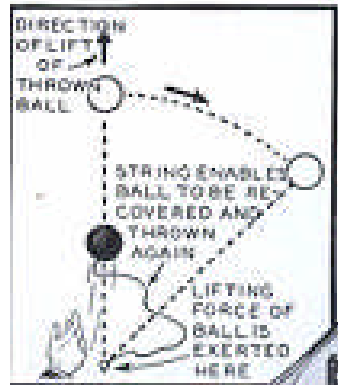

**“...Briefly, the gyroscope combines gyroscopic action with centrifugal force. As described in the prospectus of the company, the gyroscope consists of two wheels rotating in opposite directions in the same plane. Each wheel has several weights, the arms of which are connected to eccentrics on each wheel, which propel the weights in opposite directions in such a way that a lifting effect is exerted when the weights are at the top point of travel. The exact mechanism by which this effect is produced is somewhat obscure, but a model of the device already built has been bolted to the floor of a freight elevator, it is claimed, and succeeded in raising and lowering it with ease. In this test a 20-horsepower gasoline engine furnished power. Lifting force exerted by the gyroscope is likened to that of a ball thrown on the end of a string. The weight of the ball at the moment it draws the string taut exerts a lifting effect on a pencil or other object to which the bottom of the string may be tied. In the gyroscope the moving weights on the wheels are analogous to the thrown ball...”**

*Modern Mechanics*, January 1931

**Left:** caption: “Phantom-view of gyro-airship, planned for production, showing arrangement of parts”

***“...To a casual scrutiny the whole idea seems very much like lifting one’s self by one’s boot straps, but the success attained with models indicates that the inventor may be successful in developing an entirely new type of aircraft. Forward motion is to be supplied by a gyroscope in horizontal plane, and steering will be accomplished by a similar mechanism. In case of accident to the lifting gyros, which would result in the ship’s dropping like a plummet, auxiliary machines are provided which are kept running at idling speed ready to be called upon in an emergency. Four hydraulic landing feet, one on each corner of the ship, absorb the shock of landing, which is expected to be insignificant since rate of descent is controlled by speed of the gyroscope. Mr. Holmes, inventor of the gyro-ship, also has the invention of a popular front wheel drive for autos to his credit, as well as a four wheel drive and a caloric steam engine. This latter machine would supply the power for the airship. As developed by Mr. Holmes, waste heat from oil combustion is used in the caloric engine to convert water into steam, which drives a turbine, and is then condensed to be used over again.”***

***Modern Mechanics, January 1931***

# Neutralizing Gravity



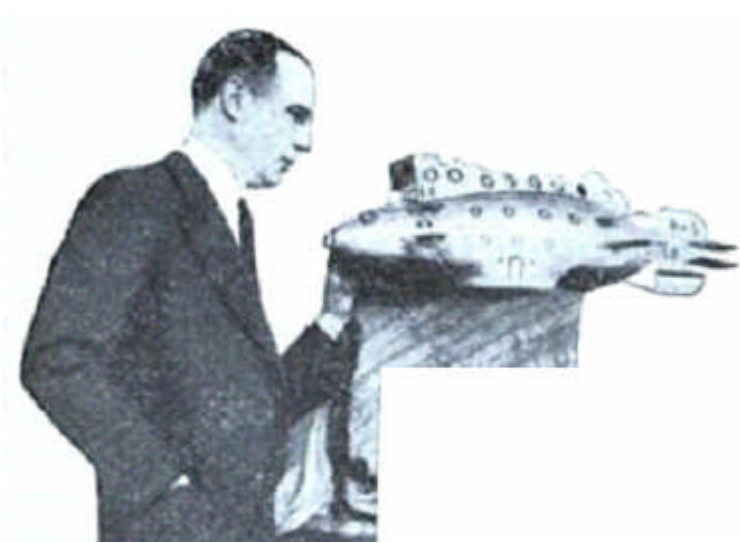

***“Propellers and engines are not needed to fly the model airship of Bernays Johnson, who is shown with his craft in the photograph at the right. A powerful radio wave which neutralizes the pull of gravity is the force which keeps the ship aloft. Johnson experimented for ten years before he succeeded in discovering the principle of his anti-gravity waves. The ship can be controlled from within itself or from the ground. It was exhibited at the recent Boston radio exposition.”***

***Modern Mechanics, January 1929***

# Corkscrew Plane



***“Can an airplane be built that will fly straight up? Many odd crafts have been built in vain attempts to solve this problem, but J.P. Sellmer, of Stinson Beach, Calif., is pinning his hopes to one of even stranger design than most. His corkscrew airplane, according to him will lift itself by means of a whirling, continuous wing of spiral design. A small propeller will keep the framework from spinning. Though aviation experts offer the idea little encouragement, Sellmer is busily putting the finishing touches to a large model with which he will test his theory.”***

***Popular Science, March 1933***

**Above: caption: “J.P. Sellmer, of California, is shown with his working model of a corkscrew plane<sup>58</sup> that he expects to rise vertically. Practical tests of the strange machine will be made soon.”**

# **Flying Egg-Beaters**

***“...A Chicago inventor...is building a heavier-than-air machine which has no wings. It is a cigar-shaped metal body, approximately thirty feet long, equipped with small retractable, feathering propellers on either side. The blades revolve in drums partly within the body, and as each blade emerges through the side it is turned by a cam arrangement, sweeps downward, feathers and withdraws again into the body. There are eight blades on either side, and the surface area is extremely small. His theory is, and wind tunnel tests have shown some reason for believing it might work, that the small, specially shaped, high speed blades will sweep the air downward from above the ship, creating a partial vacuum, and the normal air pressure beneath the ship, of 15 pounds per square inch at sea level pressure, plus the increased pressure of the displaced air, will force the ship upward into this vacuum. Altitude attained, the center of gravity would be displaced by moving a weight, and the craft would then progress forward by attempting to fall. Of course, if the engine should stop, the wingless craft would be expected to fall like a stone. But to offset this danger he is planning to install a flywheel, revolving at tremendously high speed, in which he can store up millions of foot pounds of energy, to be used in making an emergency landing. A flywheel of about 25 pounds in weight, revolving at extremely high speed, could be used to store up enough energy to turn the propellers for five or ten minutes while landing...”***

***Modern Mechanics, October 1930***



***“Paddle wheels take the place of wings, stabilizers, and propeller on a new airplane designed by a University of Washington scientist to permit hovering in the air and slower landing speeds. Revolving vanes in these wheels would propel the plane and control its vertical movements. Two paddle wheels are attached to the fuselage in the position ordinarily occupied by the wings, and two smaller ones replace the stabilizers and elevators near the tail. The larger wheels, or cycloidal propellers as the inventor calls them, have six vanes attached to a revolving disk. Only four vanes are carried by the smaller wheels. In addition to its ability to hover and land at low speed, the new craft, its inventor says, possesses unusual advantages as a fighting ship, having nothing to obstruct gun fire.”<sup>61</sup>***  
***Popular Science, November 1934***

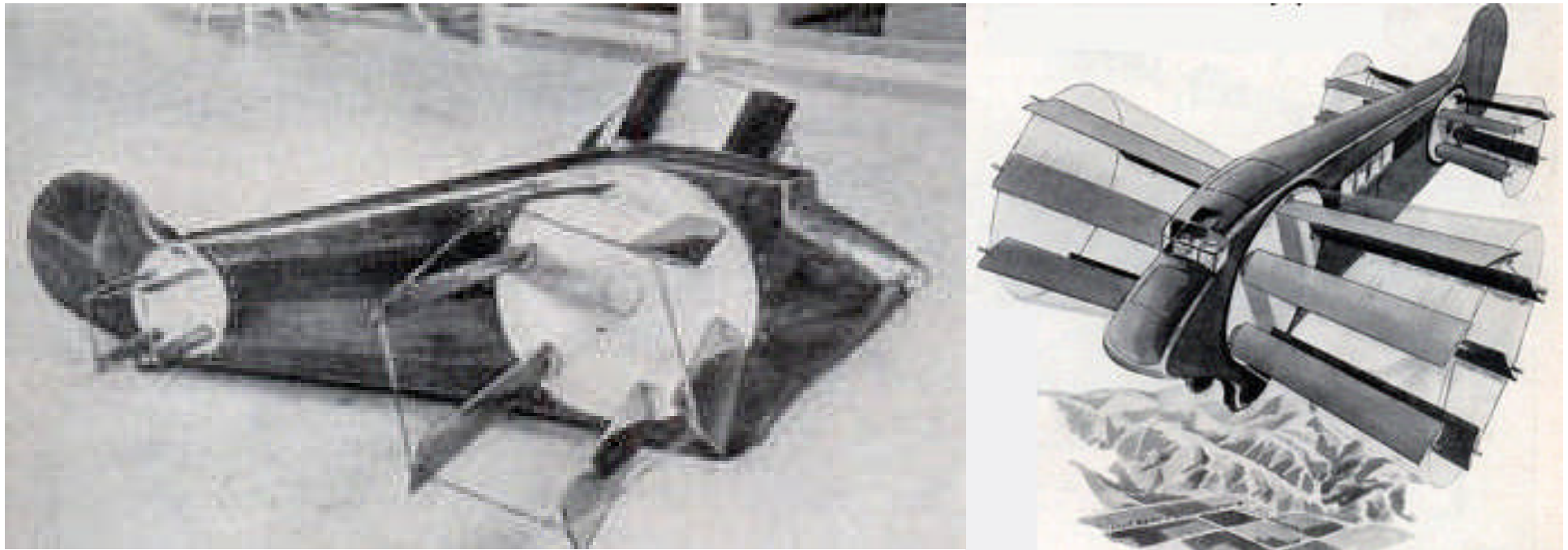

**Left: caption: “Revolving blades resembling somewhat the working parts of an egg beater replace wings and tail stabilizers on the ‘cycloidal flying machine,’ an airplane designed to reproduce the best features of an eagle’s flight. A seven foot model of the unusual craft has already been built in the aeronautical laboratories of the University of Washington by its inventor, Dr. Frederick K. Kirsten. The novel wing mechanism is expected to give higher speeds, hovering flight, and slower landings.” (*Modern Mechanics*, October 1934)**

**Right: caption: “Artist’s idea of plane in flight” (*Popular Science*, November 1934)**

Airplane design faces radical change. Prof. Kirsten's cycloidal propeller is ready to emerge from the experimental stage into a safe, wingless craft. In Europe ships are being developed eliminating not only wings, but motors also.

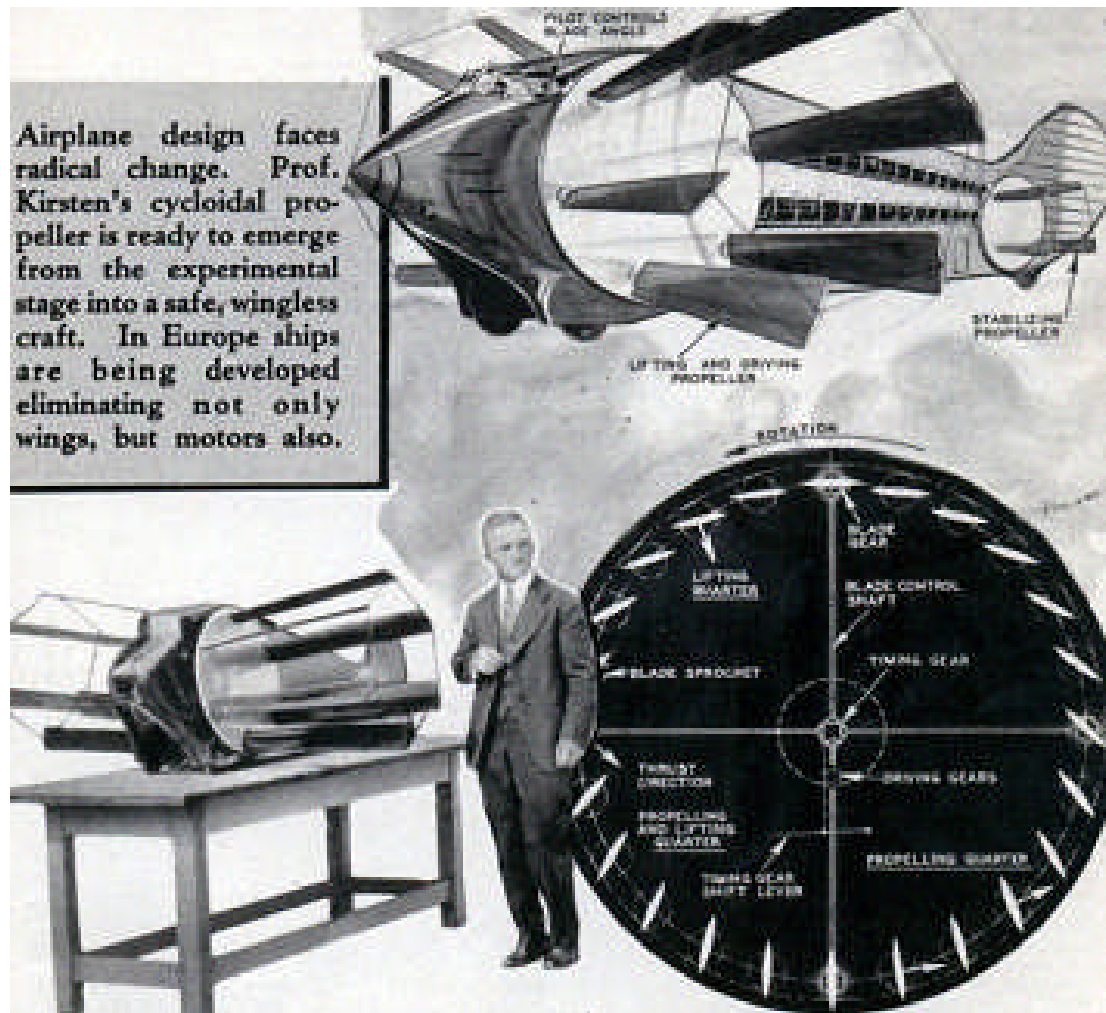

***“...For 15 years Prof. F.K. Kirsten of the University of Washington has investigated the possibilities of cycloidal propulsion and sustentation. It suggested itself to him while he was engaged in an attempt to analyze the flight of birds. Speculation as to the characteristics of the actual path traced in the air by the tip of the bird’s wing led him to conclude that this path might resemble the path of a cycloid, which finds expression in the cycloidal propeller, in which several flat surfaces, or wings, are rotated about a center...”***

*Modern Mechanix, October 1935*





***“...Birds, we know, possess the powers of sustentation - the lift of an airplane wing - and propulsion - speed from the propeller - in the same mechanism, the wings. Too, birds are far more versatile than airplanes in their ability to take off and land and to engage in rapid flight. Here is another important point, which in the past has not been even remotely approached in fixed-wing airplanes; birds have neither rudder nor ailerons, although they do possess a horizontal stabilizing fin in the form of tails. They accomplish every manner of control, including pitch, roll and yaw so familiar to airplane pilots, by moving the wing system...”***

***Modern Mechanix, October 1935***

**Left: caption: “This cycloidal propeller, 15 ft. in diameter, was built for Prof. Kirsten’s experiments. It was powered by a 400 h.p. Wright aviation engine. Each blade is 22 inches wide and 54 inches long. It has 24 blades. In tests the entire propeller made about 80 r.p.m.”**

# The Cyclo-Copter

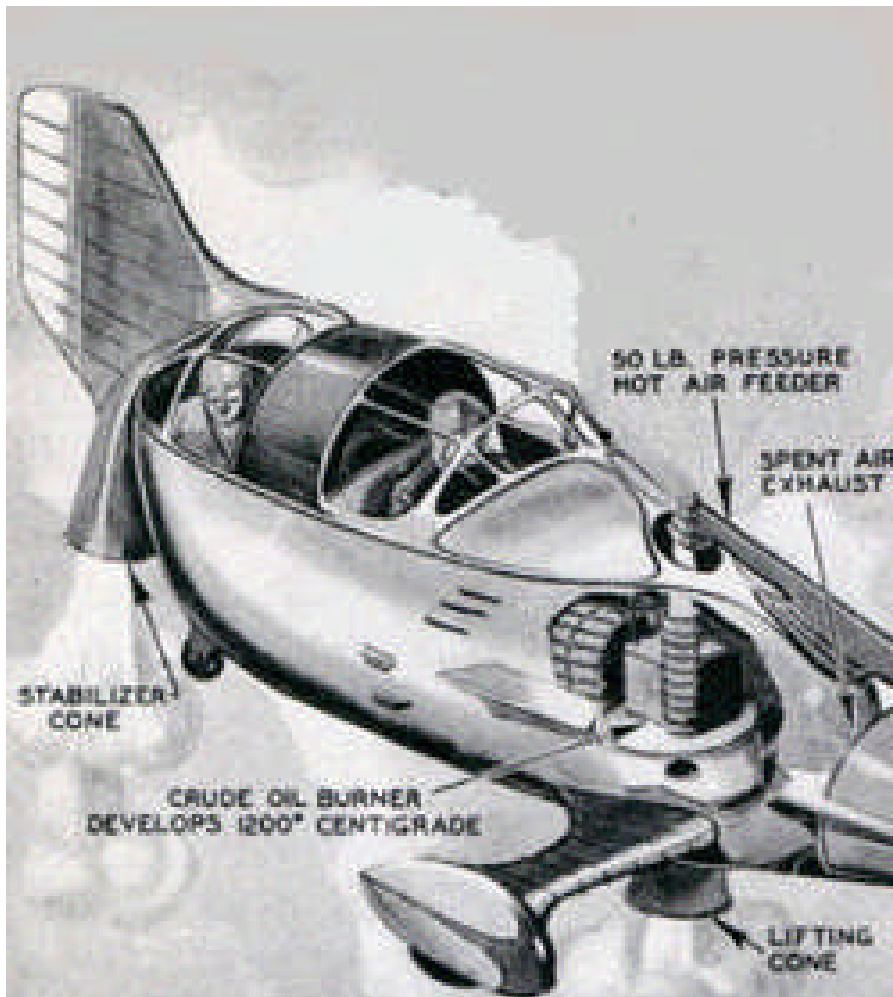

**“...’Thus the new cyclo-copter,’ Professor Kirsten told me, ‘with which we are now experimenting at the Guggenheim Aeronautical Laboratory, University of Washington, possesses a rotating wing-propeller system as in birds and gives us the advantages of free flight enjoyed by those inhabitants of the air. It’s interconnected plane surfaces, representing a bird wing, by their inter-related motions as they revolve, react upon the air in such a way as to**

**derive effects of lift and propulsion quite like those achieved by a bird’s wings. When fitted as a cyclo-gyro, the air screw and the cycloidal propellers are turned independently. In**

**this case the air blast from the propeller starts the blades turning. Whereas the screw may turn up to 2,000 r.p.m., the cycloidal propeller will deliver adequate thrust and lift while revolving only 350 r.p.m.’...”**

**Modern Mechanix, October 1935**

The wingless-motorless craft being developed in France is visualized by an artist in the drawing above. Details have not been revealed, but the ship is known to have a burner which forces hot air through conduits to lifting and propelling cones. Fifteen cones in front of the pilot’s cockpit and one in the rear lift the ship, while those in the nose pull the ship forward. Hot air forced through the cones causes suction at the wide ends. The ship, invention of Paul Dupuy de Lôme, is expected to have a cruising speed of 120 m.p.h.

***“...Blades of the cycloidal propeller on this astounding new craft are so arranged mechanically that each makes a half turn for every revolution of the entire propeller. In level flight, for instance, the blade at the bottom of the circle stands on edge, presenting a flat surface to the air stream. This enables it to deliver maximum thrust in pushing the machine forward. If that blade is moving backward at a rate of 100 miles an hour, the top blade, which is now lying horizontal in the air stream, is moving forward 200 miles an hour with respect to the air-speed of the propeller blades on their orbit plus the speed of the machine which supports it. This gives the top blades four times as great a lift per unit area than for a fixed wing. Together, these tiny wings operate with superior efficiency in propulsions and furnish the required lift at the same time. ‘It will not be necessary to fit these machines with propellers,’ Professor Kirsten told me, over the whir of the air-screw spinning on the model. ‘Experiments indicate the rotors alone will give them positive control, greater stability than theretofore has been possible, and an ability to land almost vertically even should the power plant fail.’ The cyclo-gyro model already built represents a one-sixth scale replica of a 10-passenger transport plane. Later a full-size craft will be constructed. An entirely new flying technique will be used by pilots...”***

***Modern Mechanix, October 1935***

**Right: caption: “Prof. Kristen’s cycloidal propeller in operation. The spring balance measured horizontal thrust, while scales under roller supports on one side of the frame determined torque. Streamers were used to indicate direction of air flow. Since revolving blades are invisible, pilot’s vision in cyclo-copter would not be obstructed.”**

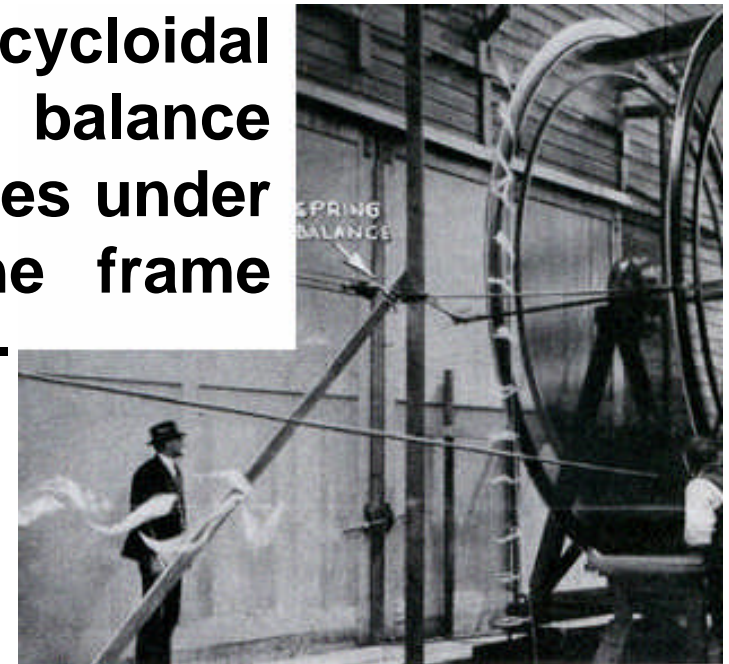

***“...‘Since it does not employ a rudder, the pilot merely turns the wheel right and left for turns and banks, moves it forward and backward to glide or climb,’ stated Prof. Kirsten. ‘When he turns the wheel left, for instance, control wires cause the angles of the blades in the propellers to be changed in opposite directions, raising the right side and lowering the left. Meantime the tail propellers serve to align the body of the machine in straight flight. Such is the accuracy and positiveness of control that a stabilizing vertical fin becomes unnecessary. Merely by turning a small wheel the pilot can change the thrust on the blades, now driving forward in level flight, again hovering over a single spot like a bird. By making adequate changes in the propeller system to achieve high pitch,’ said Prof. Kirsten, ‘there seems to be no limit to speed attainable. I am sure we can reach speeds and altitudes exceeding those so far attained by fixed-wing airplanes, at the same time retaining the safety and controllability so necessary at low speeds. Whereas the airliner of today lands at a speed exceeding in most cases a mile a minute, the cycloidal craft may be brought to earth with little if any forward momentum, much as the autogyro lands. Too, the cycloidal machine promises valuable military possibilities. Most of the noise of present airplanes comes from rhythmic impulses imparted by propellers to the air. The frequency of the sound made by the cycloidal propeller is too low to be heard. The cycloidal machine may hover over an enemy, silent as the night, while observers take note of movements on the ground. Its mission accomplished, it can speed away to safety faster than any airplanes yet constructed. Further, for fighting purposes, since the vision from the pilot’s cockpit is unobstructed by wings, due to the rapid motion of the cycloidal propellers, and since there is no propeller in front of the cockpit to interfere, machine guns of adjustable sweep may be installed.’”***

***Modern Mechanix, October 1935***

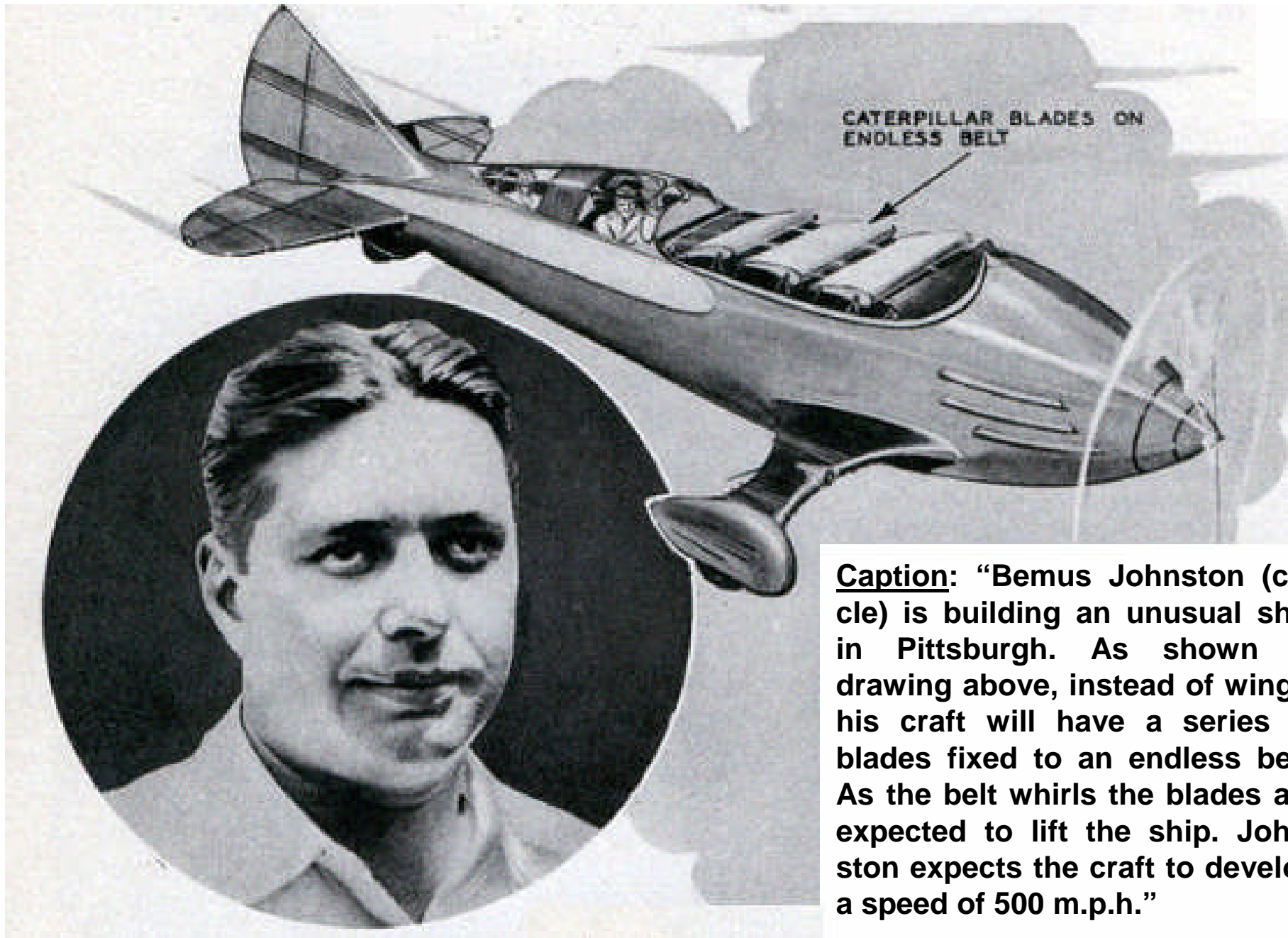

**Caption: “Bemus Johnston (circle) is building an unusual ship in Pittsburgh. As shown in drawing above, instead of wings, his craft will have a series of blades fixed to an endless belt. As the belt whirls the blades are expected to lift the ship. Johnston expects the craft to develop a speed of 500 m.p.h.”**

# **An Autogyro on the Flat**



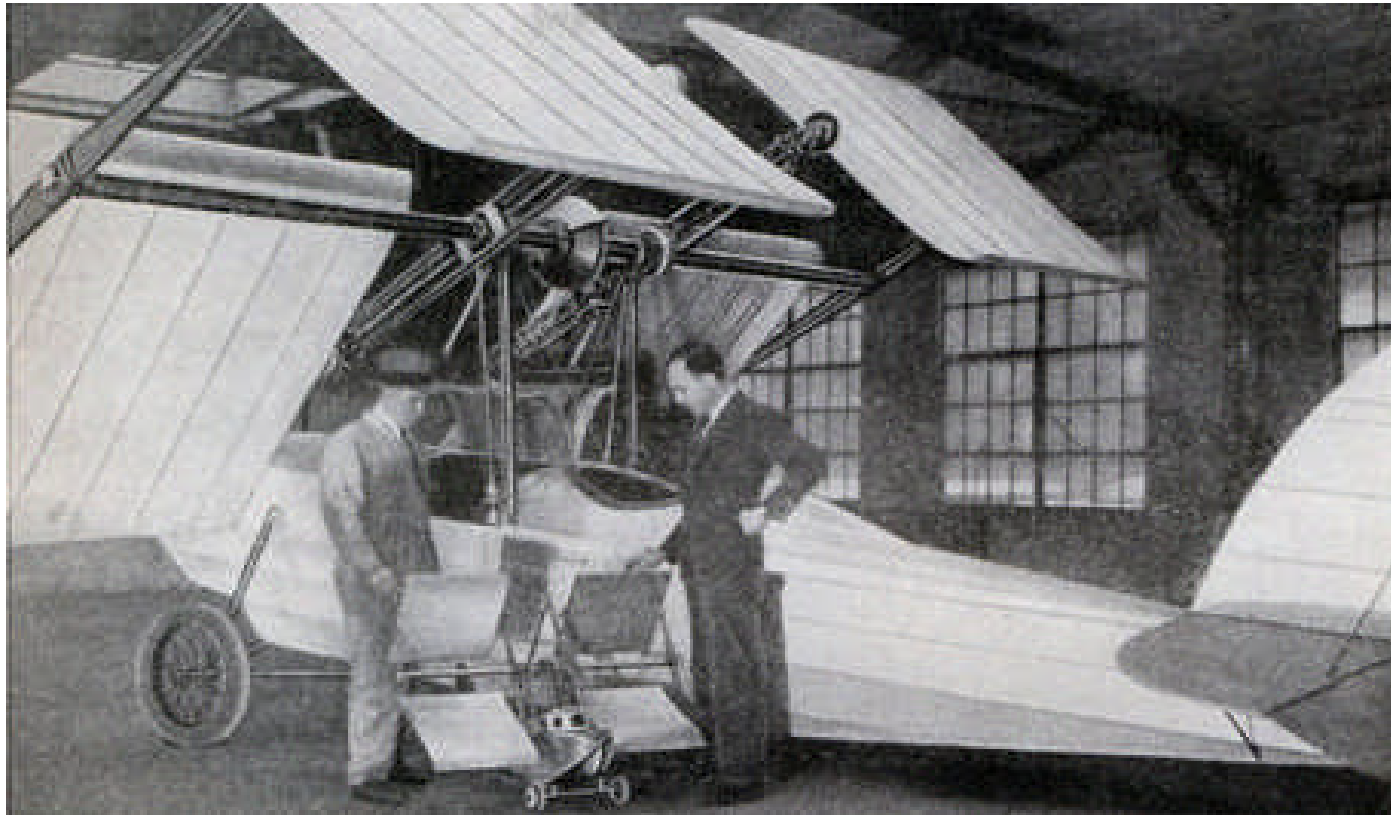

***“A new type of plane which can rise vertically and fly forward or backward, or hover in the air was successfully tested the other day in New York. It is the invention of William Rahn, right, in photo above, who constructed the craft with the collaboration of Gus Miller, left, formerly with the Zeppelin works in Germany. The strange looking sky hopper is powered with a Wright Whirlwind motor and is said to be capable of a speed of 135 miles per hour. While this is a news flash and no further details are at this time available, the principle seems to be sort of an ‘autogyro on the flat.’ The wings are disposed about a central axis and apparently change their incidence so as to produce both lift and negative drag which hops the ship along. Possibly the tests were not successful, for nothing further seems to have startled the world from this source, although a plane of these characteristics would certainly set the world on its ear, so to speak.”***

72

***Modern Mechanix, March 1933***

# **Auto-Airplane**

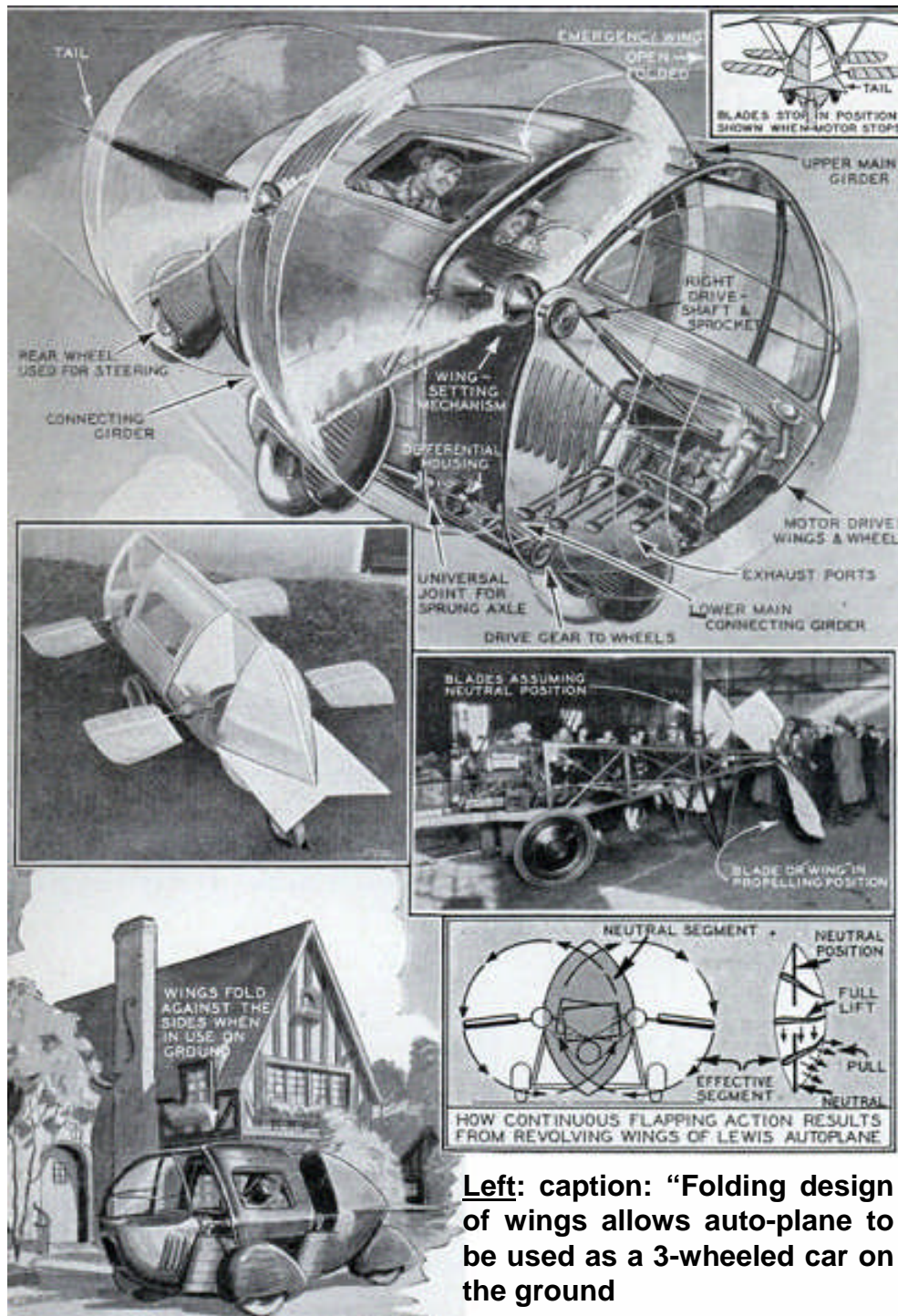

***“Built entirely without propellers as such, but deriving lift from revolving wings which spin in windmill fashion, a unique auto-airplane invented by Paul Lewis, of Denver, Col., gives promise of portending a new trend of development. Principles of its construction are explained in these photographs and drawings. One of the photos shows the lifting wings being tested in the workshop, where they developed a vertical lift of twelve pounds per horsepower.”***

**Left:** caption: “Folding design of wings allows auto-plane to be used as a 3-wheeled car on the ground

***Modern Mechanix, June 1933*** <sup>74</sup>

# The Airwheel

***‘Just as the propeller supplanted the paddle wheel, revolutionizing shipping, so are the new Voith-Schneider vertical feather-blades, successfully tested in Germany, expected to supplant the propeller. The blades, mounted on a rotating disk, have been used for the past two years on river and harbor boats with marked economies in operation coupled with a decided increase in maneuverability. As***

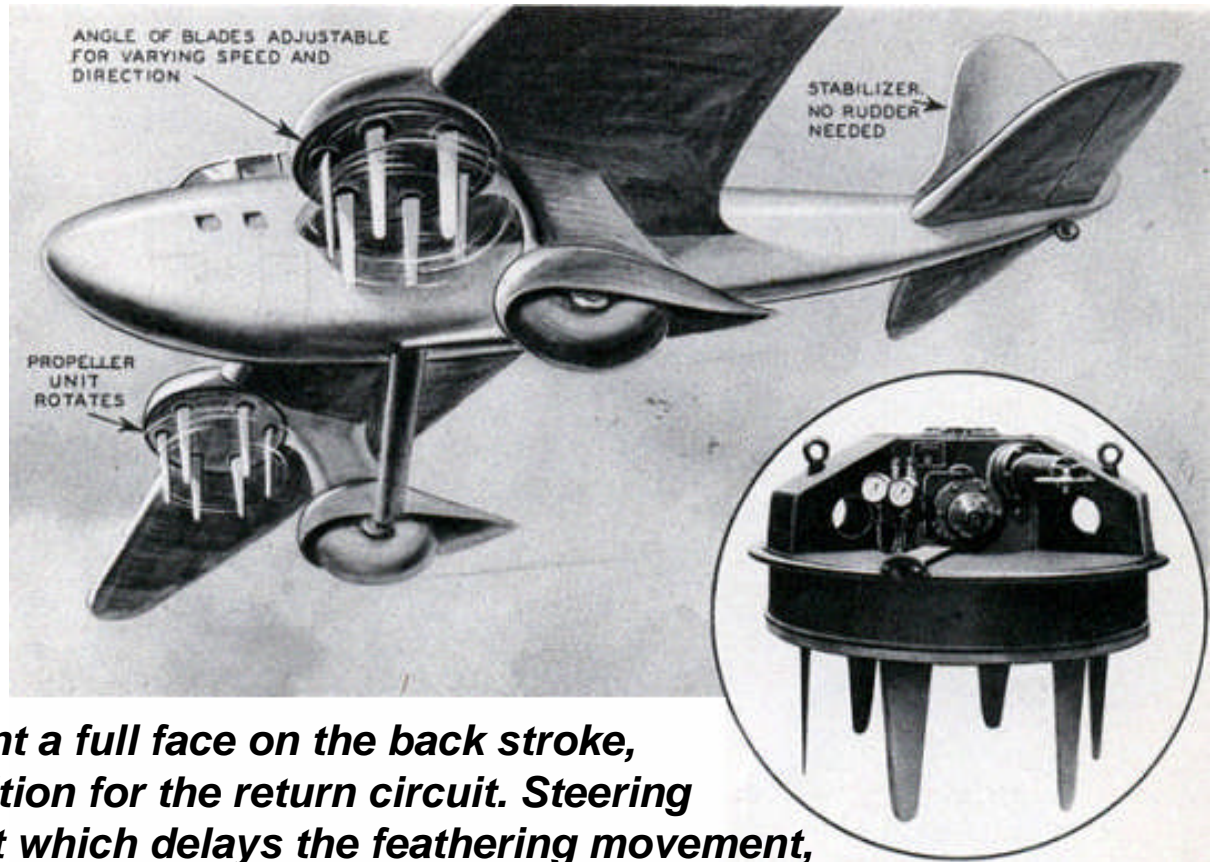

***the disk rotates, the blades present a full face on the back stroke, and then assume a feathered position for the return circuit. Steering is accomplished by an adjustment which delays the feathering movement, the open faced blades thus pushing the stern of the vessel to starboard or port as desired. The next step now being attempted by German engineers is the adoption of the vertical feathering blades to aircraft. Among the advantages claimed for the Voith-Schneider system is that it will permit greater streamlining, all motor mountings being concealed within the plane, and that it will eliminate rear rudder steering. The blades for aircraft will be larger and of much lighter construction than those in use on boats. Steering will be accomplished the same as in boats.’***

***Modern Mechanix, November 1935***

***Above: caption: “The artist’s conception of an airplane of the not-too-distant future if German engineers are successful in their present plans. Vertical feathering blades on rotating disks, similar to those now in use on boats, as shown in circle, will be tested on the new airplanes.”***

**Caption:** “The Veith-Schneider horizontal paddle wheel, which is adapted to navigating flat-bottom boats in shallow water, is much like the Airwheel in principle. A mechanism which adjusts the angles of the blades, during their revolutions, causes them to exert pressure in any desired direction, and thus propel and steer the vessel, without the need of a rudder (adapted from La Science et La Vie, Paris).”

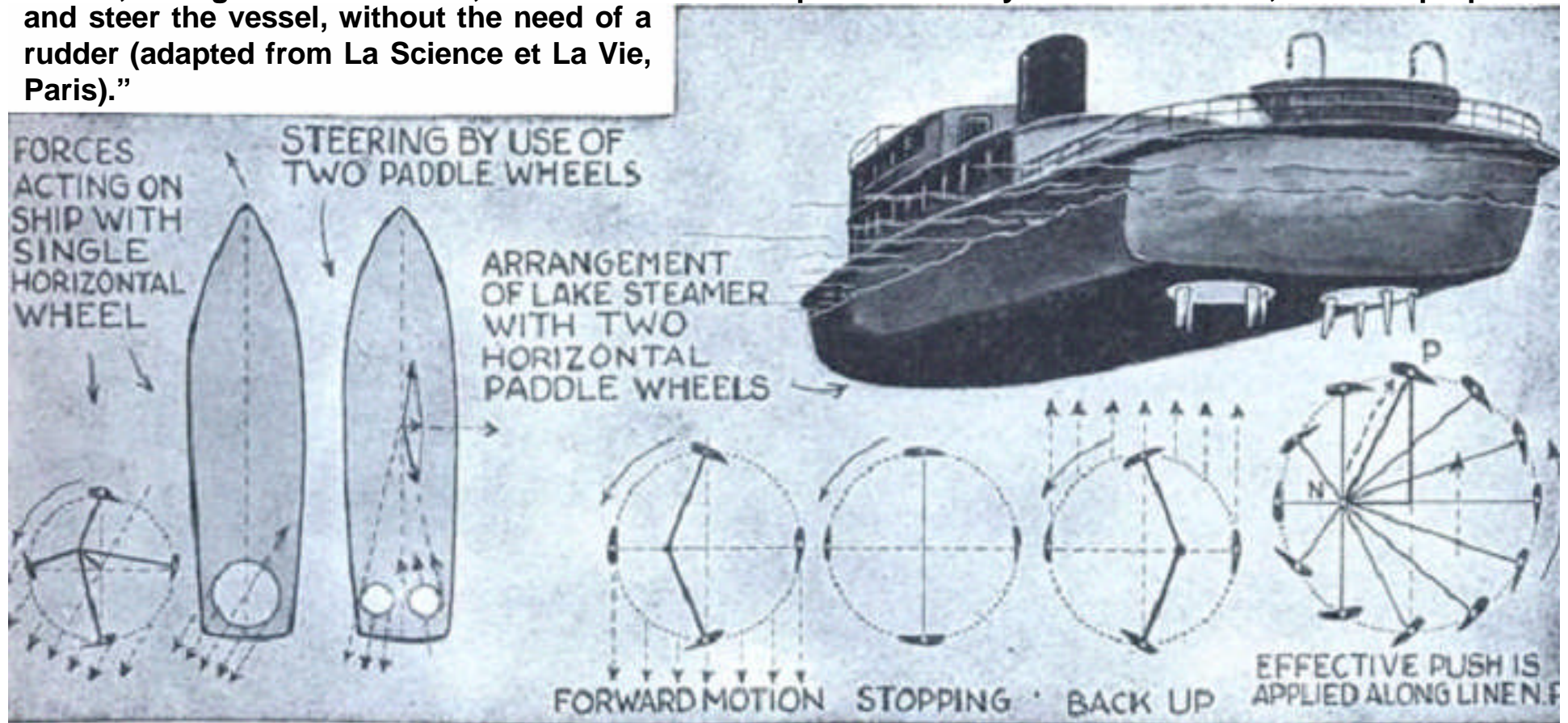

**“...It’s interesting to note, in connection with the Airwheel, a new ‘water-wheel’ or type of propeller, now in use with fairly large vessels, of several hundred horsepower, on Lake Constance, and the river Danube, in Europe. The propeller discs are set, at right angles, with four to six blades, whose settings are changed by gears as they turn.”**

Original MONEY-MAKING PLANS

SEE  
PAGE  
32



EVERYDAY

January

# Science and Mechanics



25  
Cents

Canada 30 Cents

HUGO GERNSBACK  
Editor

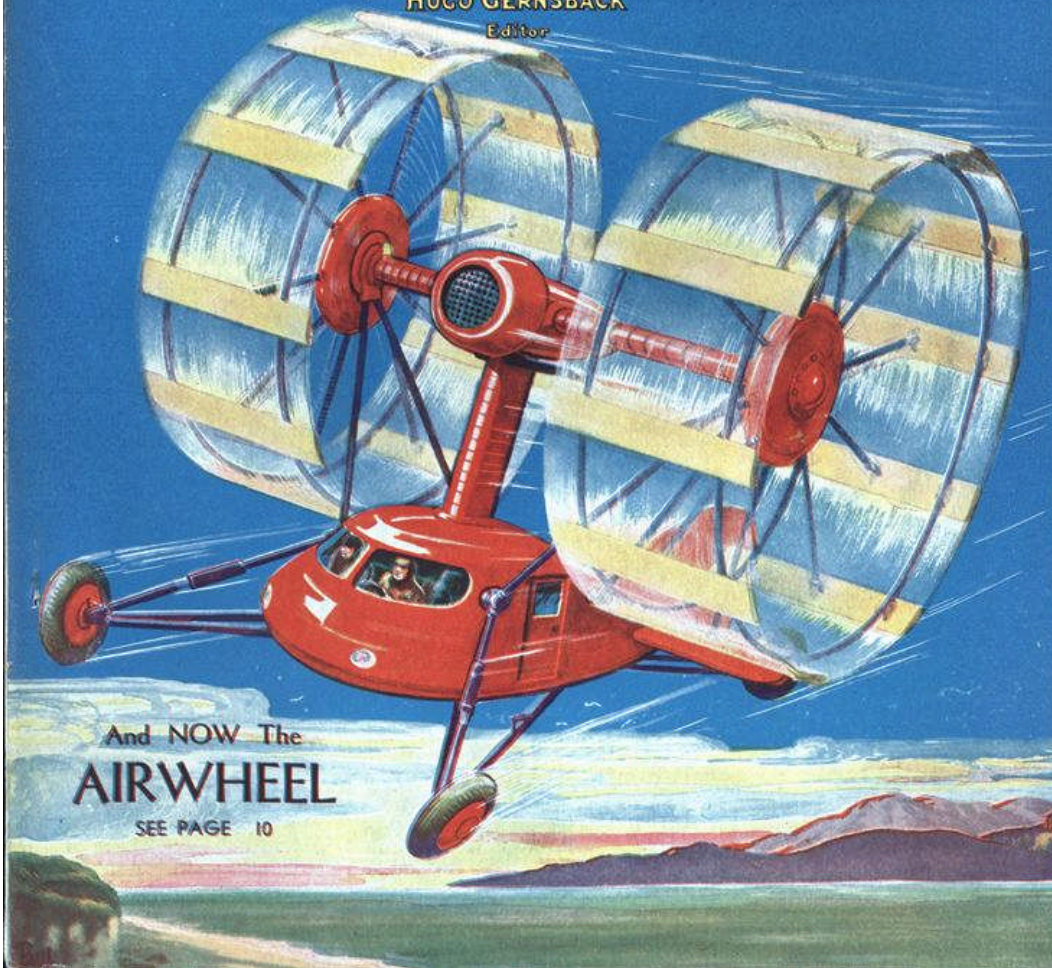

And NOW The  
**AIRWHEEL**

SEE PAGE 10

*“Many attempts have been made, both before and after the invention of the airplane, to develop a craft which should really fly. The ornithopter, or bird-wing craft, has not been successful in its motion, any more than mechanical devices which simulate walking. The bird, like the man, has a great many controls in its muscular equipment, which are difficult to imitate in a machine. However, during the past few years, the idea of a revolving wing has been attracting more and more inventive effort. The craft illustrated represents one of the most practical principles, and will be carried into practice within a short time. It has two Airwheels, which not only propel the craft, like the paddle-wheel of a river steamer, but also supply lift...The wheel is equipped with ten narrow blades, each shaped in cross-section like an airplane wing, and whose setting is altered as the wheel revolves, by means of an eccentric and studded decagonal plate, which is adjusted by the pilot from the cockpit by means of a lever. Various settings enable the machine to travel forward, backward, upward, or to hover, as well as lower it gently and almost vertically.”*

Science and Mechanics, January 1934

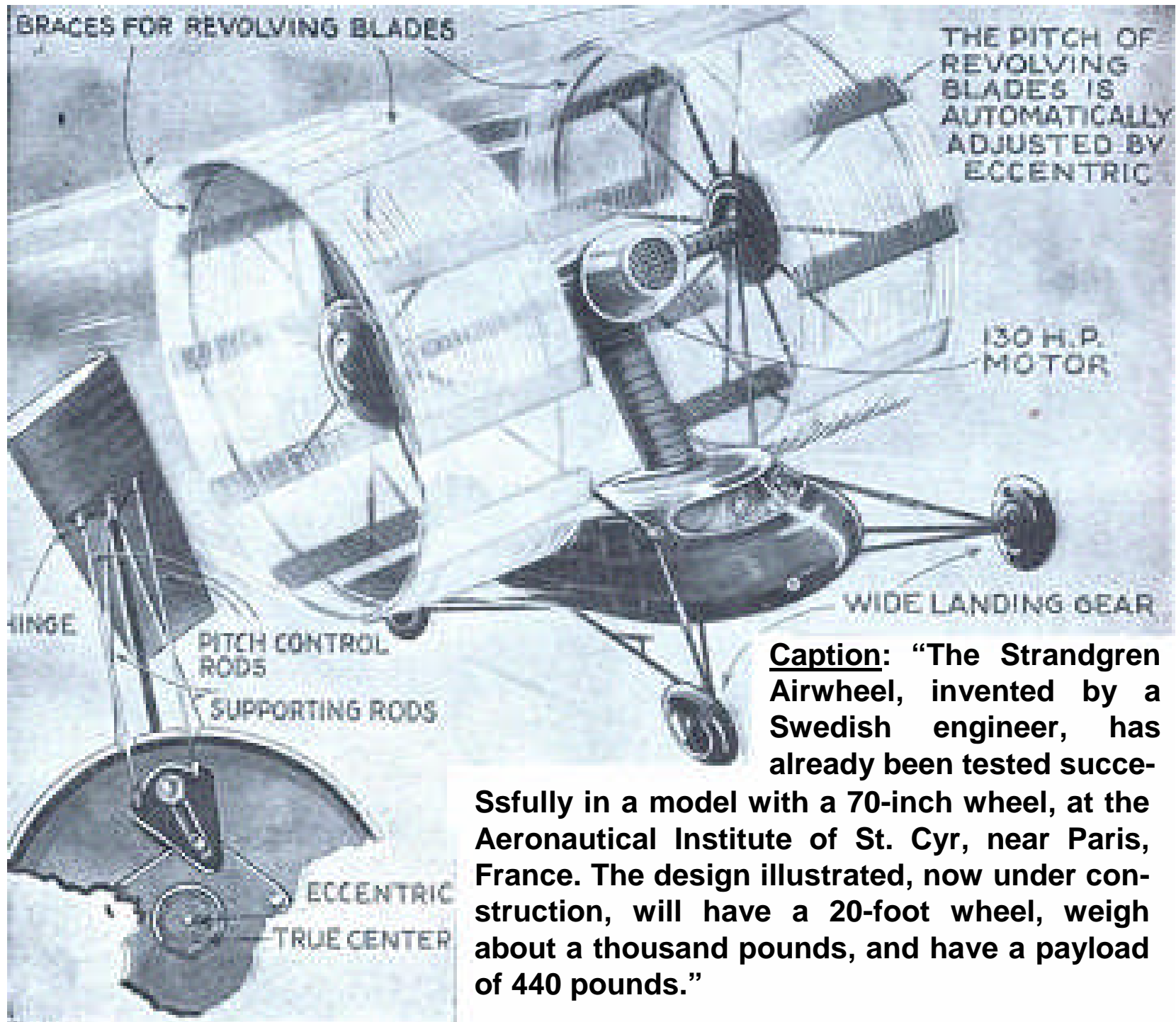

**Caption:** “The Strandgren Airwheel, invented by a Swedish engineer, has already been tested succe-

**Ssfully in a model with a 70-inch wheel, at the Aeronautical Institute of St. Cyr, near Paris, France. The design illustrated, now under construction, will have a 20-foot wheel, weigh about a thousand pounds, and have a payload of 440 pounds.”**



**“...For instance, take the positions of the blades for forward flight, as shown in the lower left illustration. The uppermost blade is lifting, in the manner of the normal airplane wing. The third blade (half of them are omitted for clearness) has had its angle to the brace changed; it is still lifting; but it is also exerting a forward pull. The fifth blade is hardly lifting, but it is pulling forward. The seventh blade (because of the forward motion of the plane) is not pulling backward, but slipping through the air. The ninth blade is exerting lift. All these pulls, transmitted through the framework, will be found to center at the point I; which corresponds, in a way, to the point at which the tractor wheel of a bicycle is touching the ground...”**

**Science and Mechanics, January 1934**

**Caption:** “The instantaneous diagram of the Airwheel (left) shows every other blade, with the carrying angles in their braces, regulated in the five-centered plate with the pivoting legs, during the rotation. The lines of pull center at I. Since the machine is moving forward, the blades describe, not circles, but the desired curves T-T. The slip of the blades causes the machine to move as if rolling on a wheel of radius  $r$ , as shown at the right. (illustrations adapted from La Nature, Paris).”

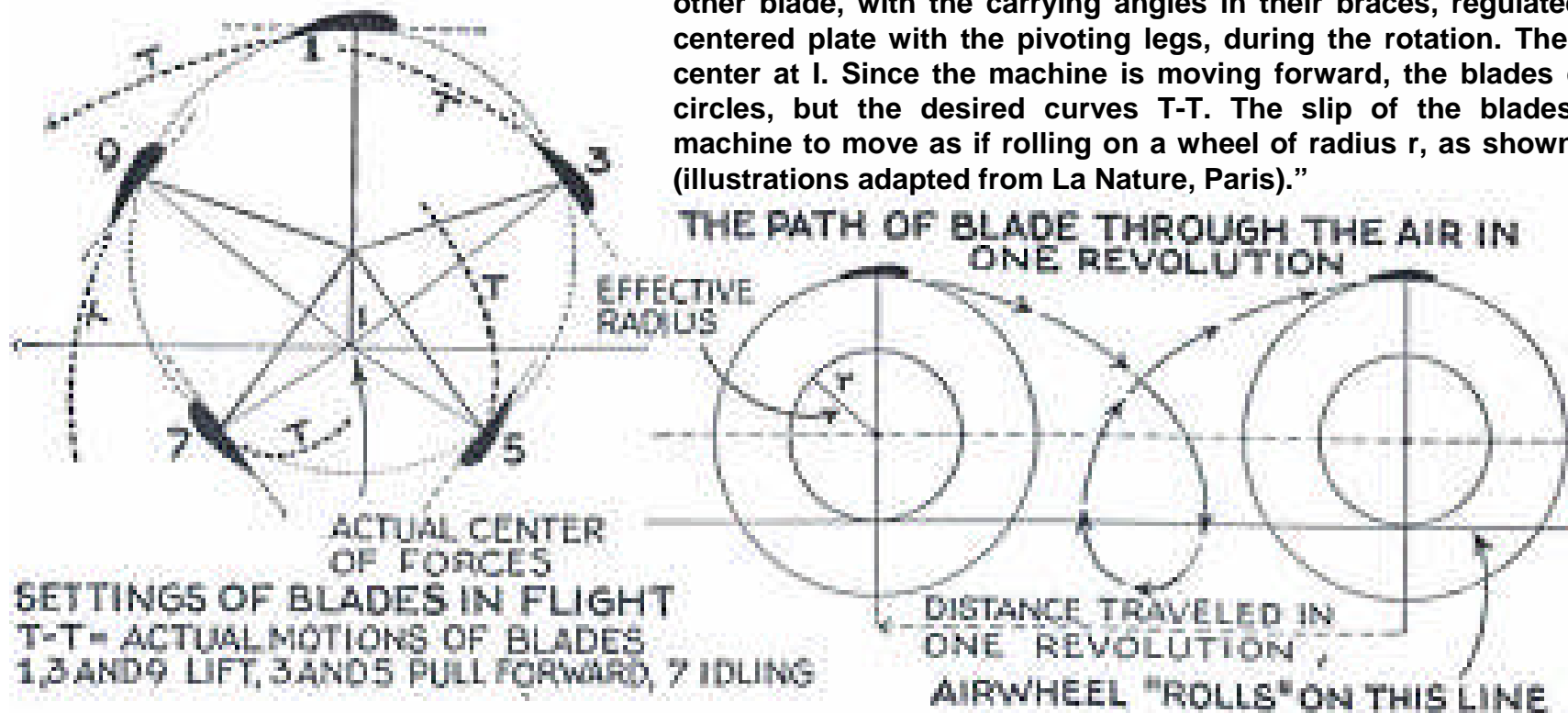

***“...The total effect of these forces is to draw the machine forward, while sustaining it in the air. A change in the setting of the blades, effected by turning the eccentric through a sleeve over the driving shaft, will change the direction of the combined forces; so that the Airwheel will exert its pressure backward, or forward. Like the autogyro, the machine will settle down almost vertically, and quite safely, with its blades revolving; though it does not seem well adapted to swift flight, it will be easy to control, and suitable for private operation over short distances, like a family car...”***

***Science and Mechanics, January 1934***

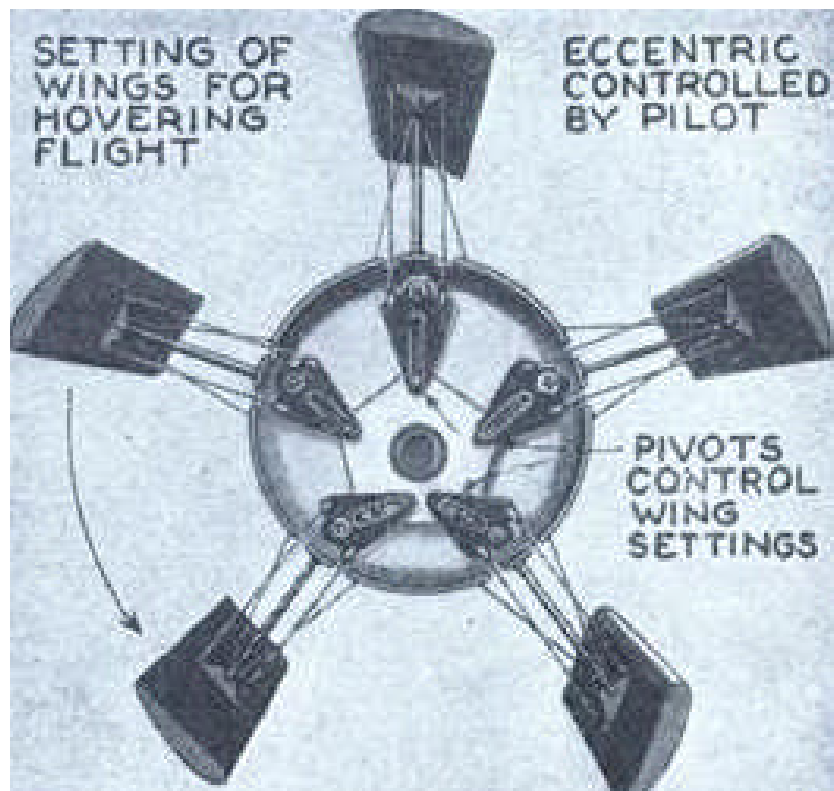

*“...The model recently tested had five wings, five feet in span (length) and 10 inches in chord (depth), on a framework 79 inches in diameter, and driven by a 4-H.P. motor. After satisfactory performance in a wind tunnel, it was decided to build a full-scale craft, of the passenger-carrying type; with a net weight of 990 pounds and pay-load capacity of 440 pounds. It will be driven at 120 R.P.M. by a 130-H.P. motor. This, with a rim speed of 125 feet per second (85 miles an hour) will give a calculated lift of about 1,760 pounds...”*

*Science and Mechanics, January 1934*

Left: caption: “The shifting of the eccentric (by a lever running from the cockpit, on the main shaft) changes the angles of the blades, at different angles, and thereby governs the motion of the Airwheel craft.”

***“...It will be observed that there is no rudder. Alteration of the settings of one Airwheel, as compared with the other, has the effect of banking and turning the machine. Since there is a slip of the machine through the air, it does not progress the full circumference of the wheel at each revolution; but about half that distance...While several designs of aircraft with revolving wings, rotors, etc., have been made, especially lately, the Airwheel seems to have greater possibilities, for its specific purpose, than most of the others...”***

***Science and Mechanics, January 1934***

# Propeller Wings

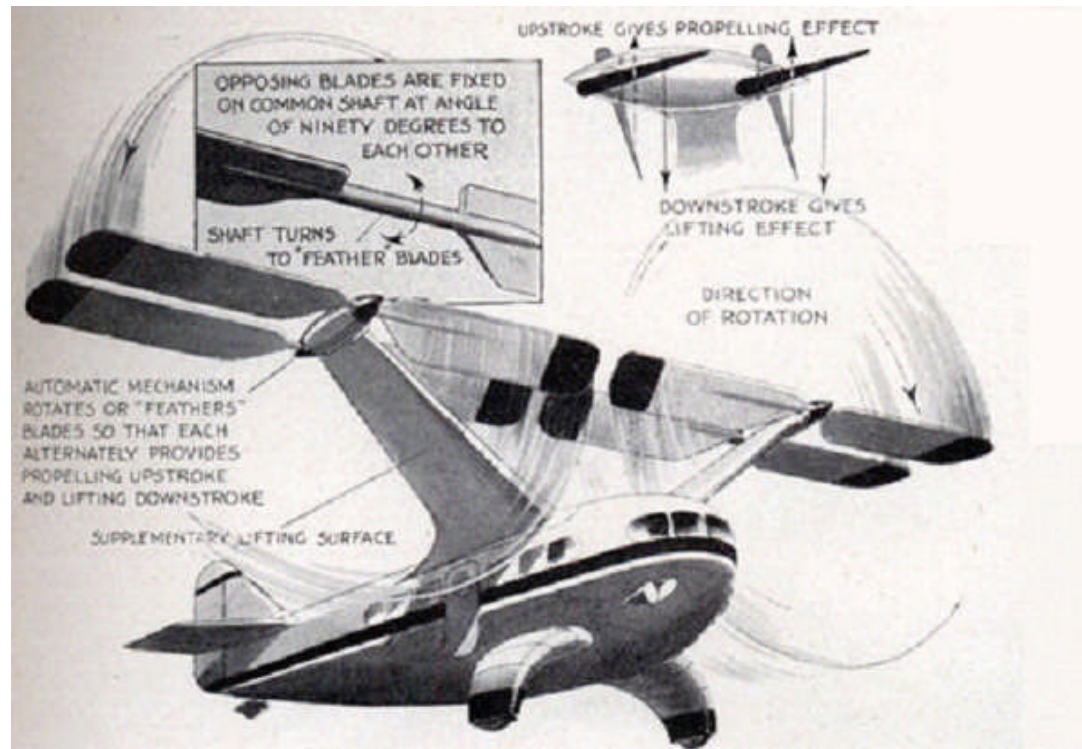

***“Threshing the air like giant paddle wheels, four huge propellers serve the double purpose of lifting and propelling an odd wingless plane designed by two Denver, Colo., inventors. Mounted in pairs on struts jutting obliquely upward from the fuselage, the ‘propeller wings’ have opposing blades fixed on a common shaft at an angle of ninety degrees to each other. An automatic mechanism turns the shafts to ‘feather’ the blades so that each upstroke propels the plane forward and each downstroke provides lift. Drive shafts in the struts connect the blades with the motor in the fuselage. The pilot may control blade pitch to gain either greater speed or more lift.”***

***Popular Science, February 1936***

***Above: caption: “Proposed design of wingless plane, showing how propellers will provide support and traction”***

# The Rotowing

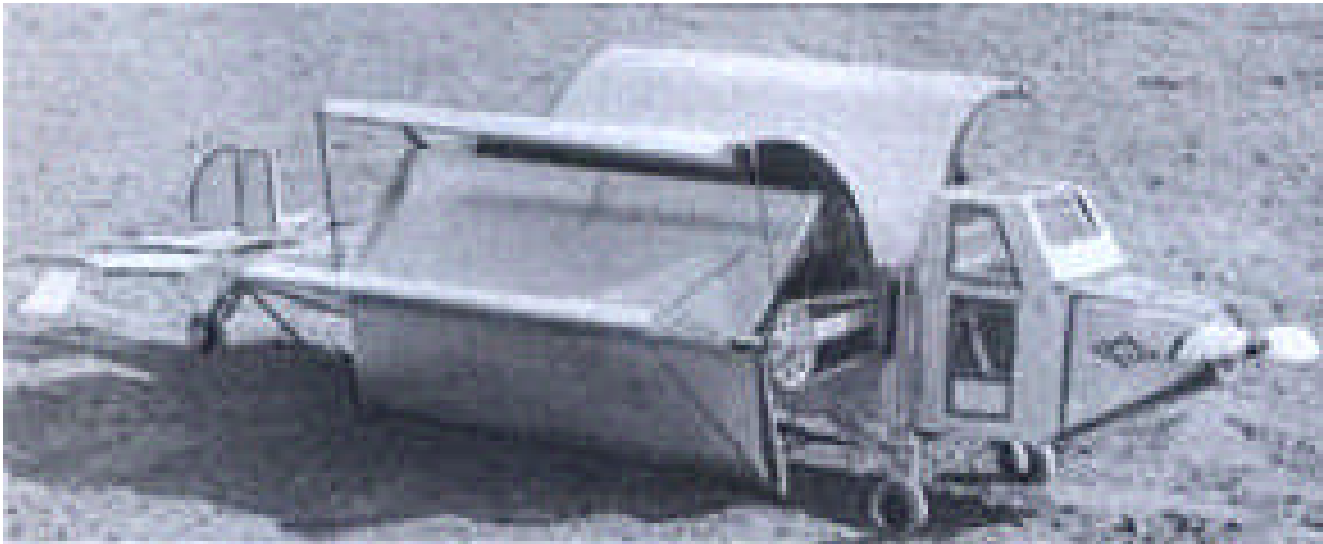

***“The Rotowing, an airplane of unusual design, has been invented by Virgil Kutnar, of San Francisco, Calif. It is designed for taking off in vertical flight without any forward***



***motion. Experiments with a small model have encouraged Kutnar to attempt the construction of a full sized plane. A sprocket chain attached to the motor supplies the power for turning the rotowings. A regulation motor and propeller cause forward flight.”***

***Modern Mechanix, November 1936***

***Left T&B: caption: “Above – this odd looking Rotowing model is designed to rise vertically without forward motion. Below – Virgil Kutnar, inventor, designing a full-size Rotowing”***



# Paddle Plane

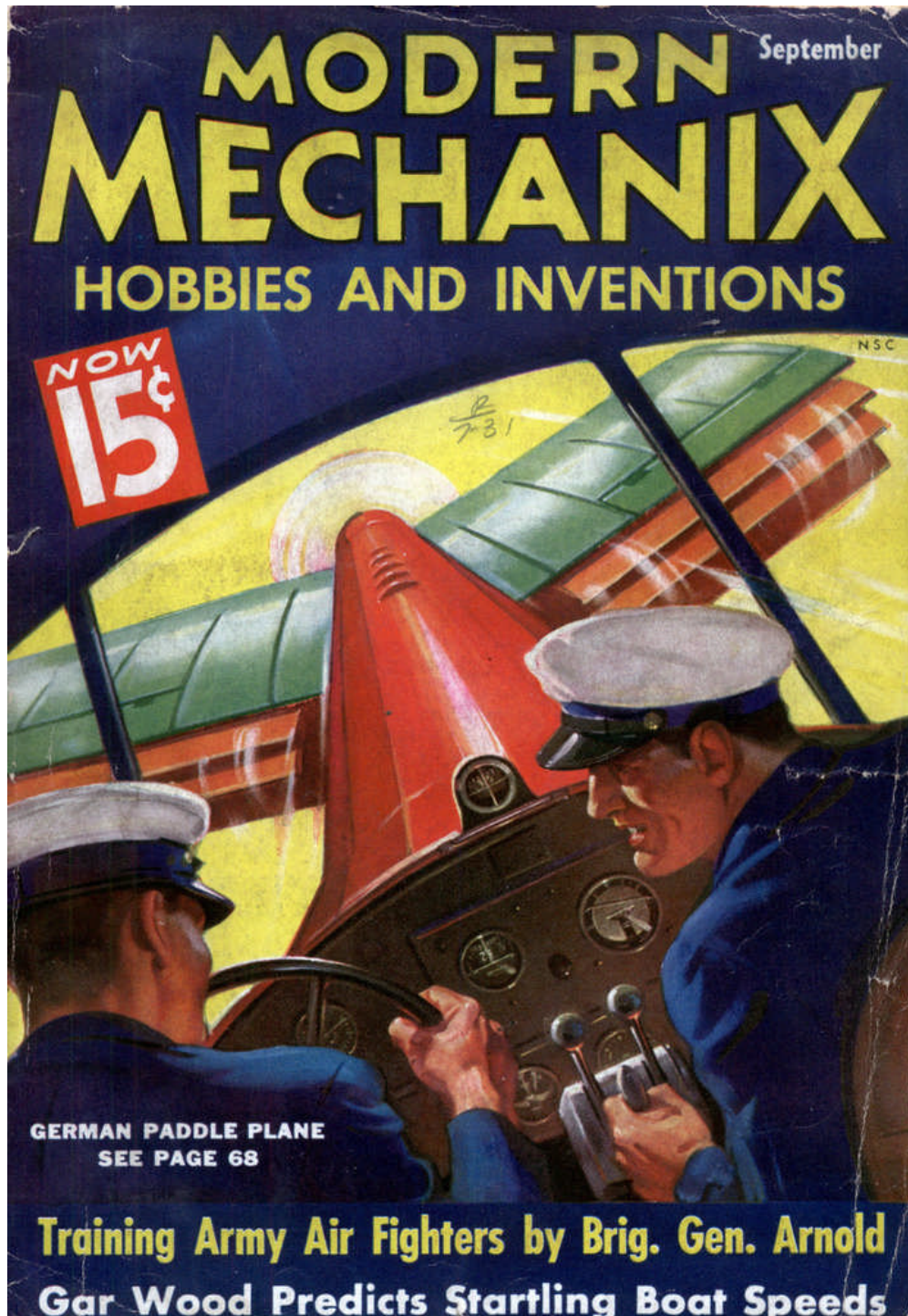

*“From Germany comes the news of another attempt to produce a plane of the rotating wing, or ‘paddle’ variety. Unlike the well-known Dr. Rohrbach’s paddle-plane design, the latest attempt to get away from conventional air-screws as a means of propulsion does not depend upon the paddles as a sole means of lift as well as propulsion. Rather, it seeks to adapt the paddle principle to an otherwise normal airfoil. The inventor, Herr Engineer R. Thebie, of Chemnitz, after studying wing-flapping flight as practiced by birds, has introduced the results of his observations in his airplane...”*

*Modern Mechanix, September 1936*

Left: caption: “Seated at the tail of the plane, the pilot has s command-<sup>89</sup>ing view”

***“...The paddles project from the lower surface of the wing and, made of flexible material, fold up into the wing itself during the upper half of the revolution. The compression of air natural to a wing in flight is thus assisted. Emerging from the wing the paddles exert a downward and lifting force. As the rotation proceeds they exert a propulsive force. Should the propulsive effort prove insufficient for practical purposes, Herr Thebie will install an auxiliary air-screw in front to aid the plane in taking off and other situations where exceptional power is needed.”***

***Modern Mechanix, September 1936***

**Right: caption: “General view of Herr Thebie’s proposed paddle plane. Driven by centrally located engines the paddles fold into the concave under surface of the wing as shown in small diagram”**

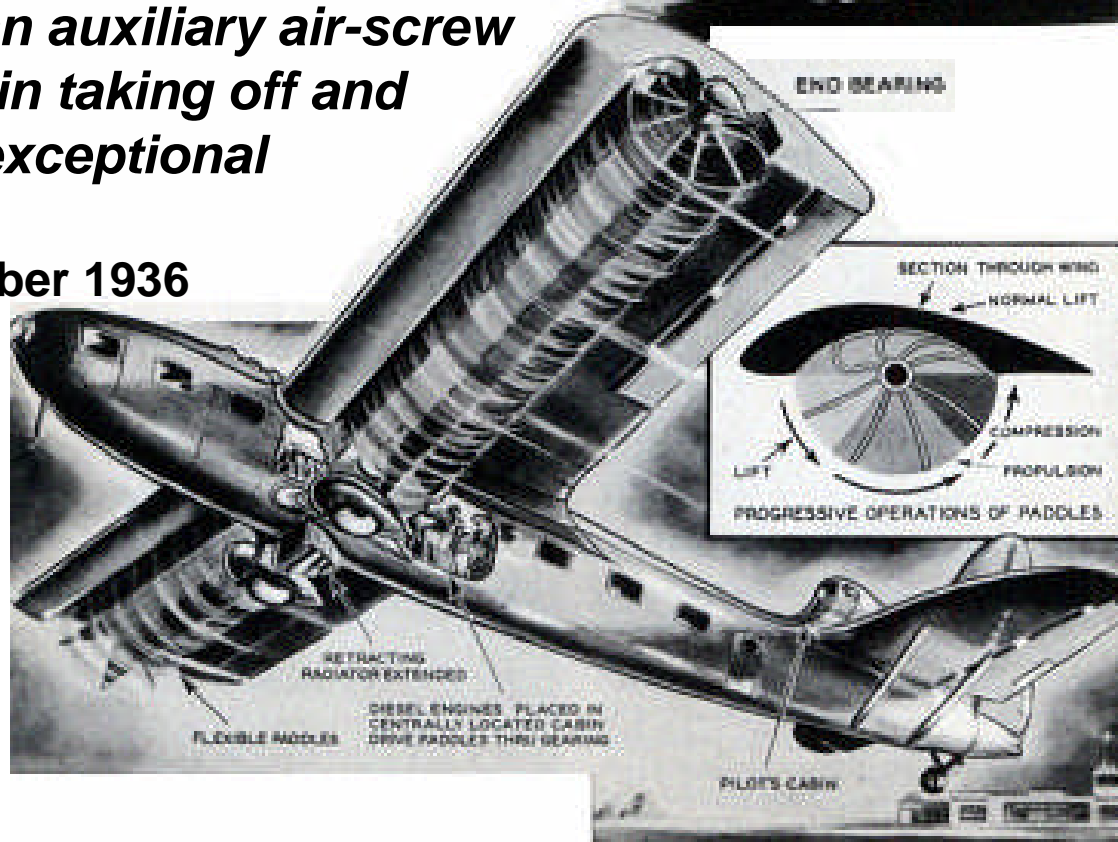

# Pulsating Plane

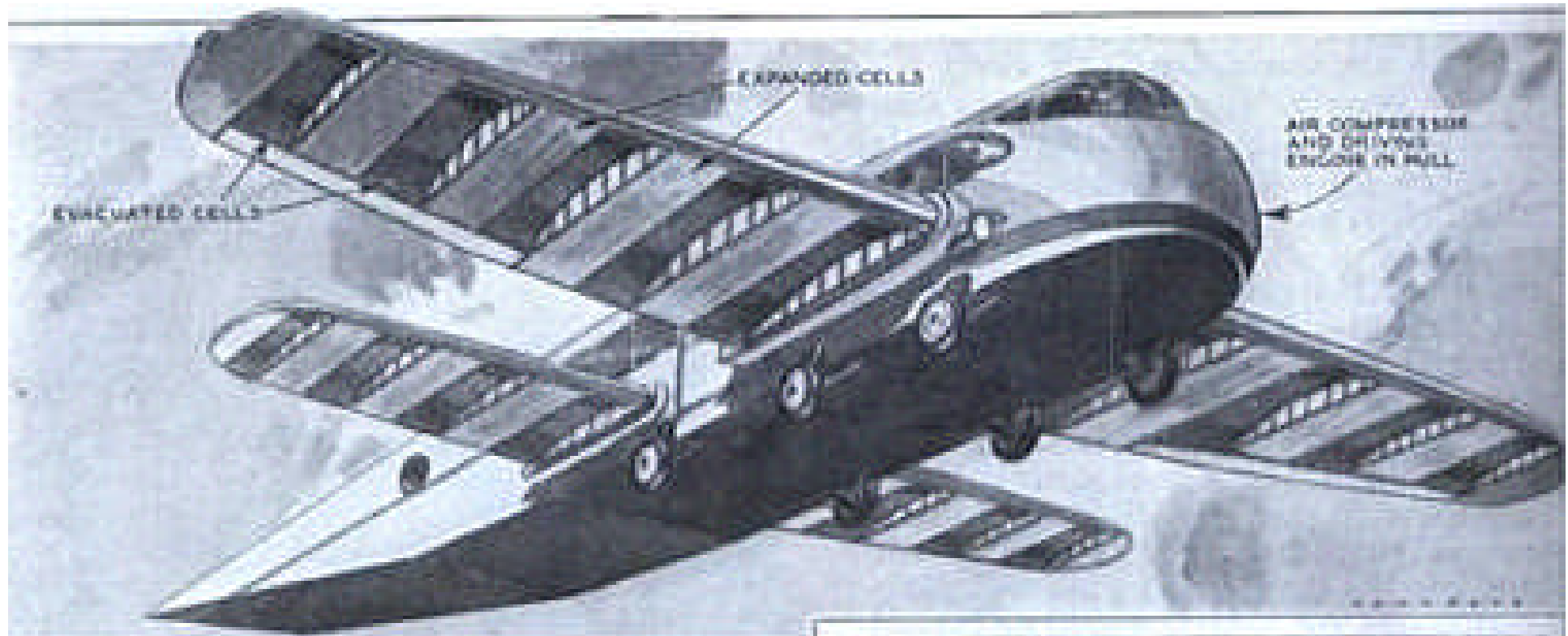

***“Lacking both propeller and tail assembly and driven only by a 10 H.P. motor, an Austrian plane is expected to take the air this summer. The motor drives a compressed air pump which expands and evacuates a large series of pneumatic air cells in the wings. It is planned that pulsations of these cells will furnish lift and driving power for the ship. By altering the stroke in the rear wing cells, which act as a propeller, the plane is expected to climb, bank, dive, hover and go forward or backward. The forward wing is used primarily for the higher speeds. The framework of the ship is constructed of welded steel tubing.”***

*Modern Mechanix, June 1934*

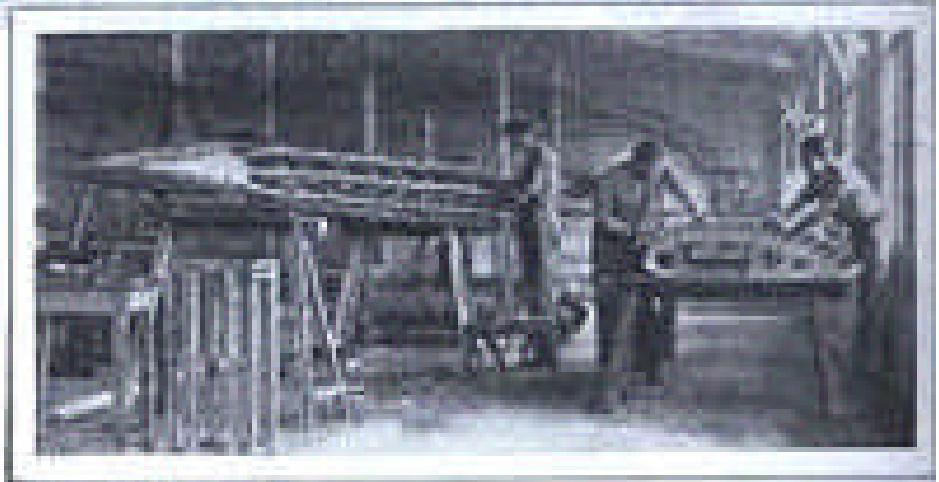

**Above: caption: “Workmen are shown building the many-celled wings which are expected to furnish the power for the strange craft.” 92**

# Who Can Tell?

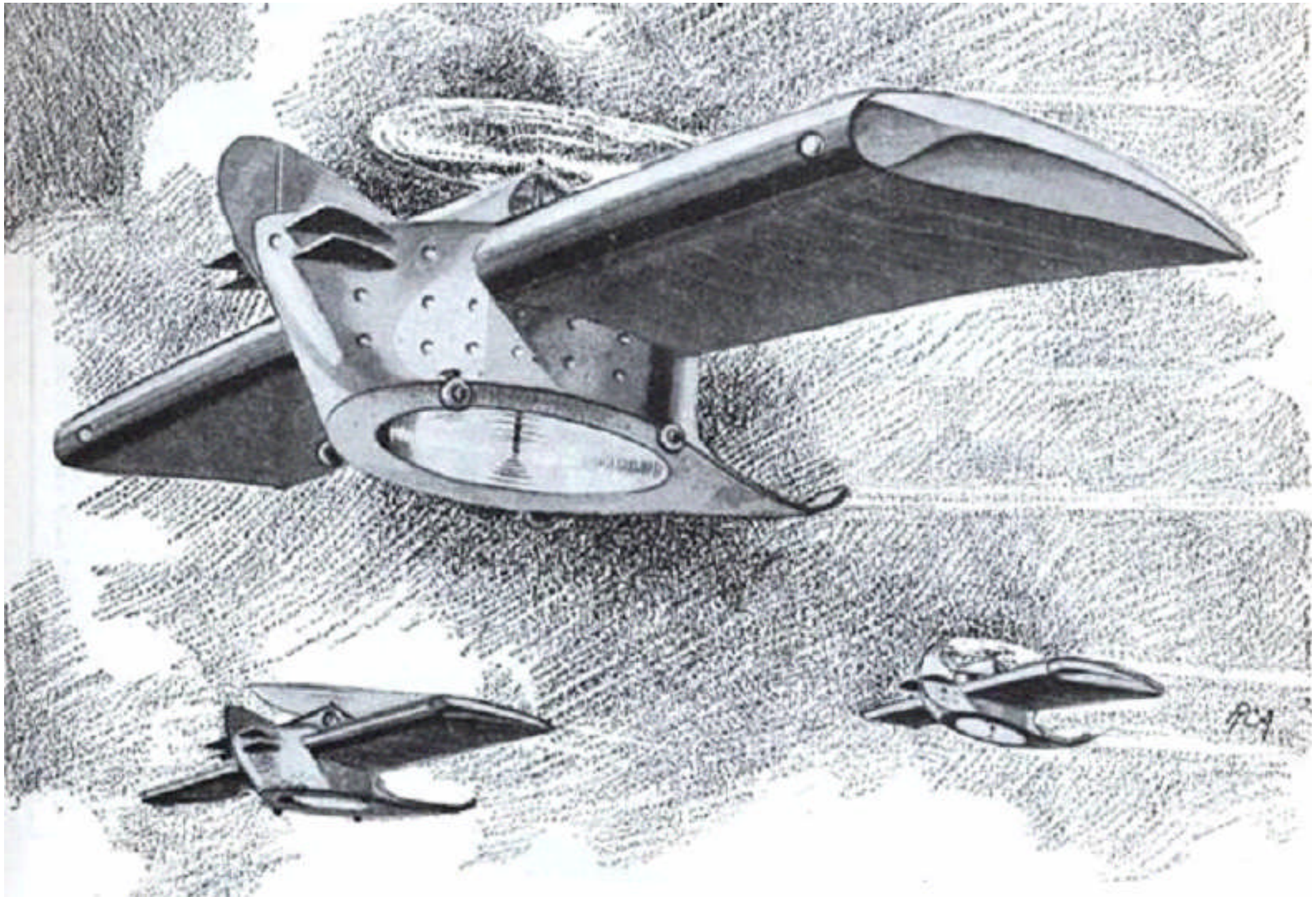

Above: caption: “Will the airplane of tomorrow look like this? Who can tell?”<sup>94</sup>

## Part 2

# A Brain Wave Airplane



**But it Doesn't Look Like an Airplane**

***“When the De la Cierva auto-giro made its first appearance in England an aviation authority condemned it on the grounds that it ‘didn’t look like an airplane’ and therefore couldn’t be much good. Another authority countered by asking what an airplane should look like. There is no reason for believing, he pointed out, that because airplanes have developed along certain lines that those lines are the best, safest or most efficient. With the exception of the few planes equipped with the new Packard Diesel engine, the airplane power plant is a direct descendant of the Wright brothers’ original four-cylinder gasoline engine. The propeller has changed but little from the first one they whittled out, though there is reason to believe that a radically different’ type of propeller might be more efficient and is bound to come. And the plane itself is still based on the earliest models...”***

***Modern Mechanics, October 1930***

**Autogiro** or **Gyroplane**, type of aircraft supported in the air by a horizontally mounted airfoil similar to that of a helicopter but un-powered. Invented by the Spaniard Juan de la Cierva, it was first flown successfully in January, 1923, in Spain. Most of the lift is supplied by large airfoils which are mounted horizontally above the craft and rotated by the airflow created by the craft's forward movement. The autogiro has fixed wings that are smaller than those of an ordinary airplane; the body and tail assembly is of conventional design. Thrust is supplied by an ordinary engine and propeller, and control is maintained by a rudder, elevators, and ailerons. In one type, fixed wings are absent, and the rotor provides all the lift. Control of pitch and roll are accomplished by tilting the rotor forward, backward, or to either side. Some advantages of the machine are that its descent will be slowed by the turning of the rotor if the engine fails; that it becomes airborne with a very short take-off run and can land in small areas; and that with a moderate headwind it can virtually hover with zero ground speed. However, it cannot match the vertical climbing performance of the helicopter.

***Columbia Encyclopedia***



***“For five centuries, since the days of Leonardo da Vinci, the genius of the Renaissance, men have been striving by means of a host of mechanisms to lift themselves vertically into the sky with heavier-than-air machines...Among the skyscrapers of lower New York City, a few weeks ago, a strange wingless craft drifted down in a vertical landing. Its wheels touched the concrete of a pier and rolled less than a dozen feet. With balancing wings eliminated, it represented the latest style in autogiros. The flying windmill has taken another step toward the goal of a thousand inventors, the helicopter. An autogiro can descend vertically; but it can take off only after a run...”***

***Popular Science, March 1935***

***Above L&R: caption: “A wingless autogiro photographed on a pier at the foot of Wall Street, where it landed after a flight from Philadelphia. It later took off from the same spot.”***



# AN AERODROME FOR EVERY TOWN

THE AUTOGIRO CAN SOLVE THIS PROBLEM



BECAUSE ANY OPEN SPACE CAN BE ITS AERODROME

The practical convenience of air travel will only achieve maximum utility when every town of importance has its aerodrome.

One of the greatest difficulties in building aerodromes for towns, particularly in industrial districts, is the acquiring of large enough areas for safe operation of orthodox aircraft.

The simple solution to this vital problem is the Autogiro.

The C 30 P AUTOGIRO can take-off in a few yards, climb steeply over obstructions, descend vertically and land without forward run. It can be operated safely in small areas such as would be impossible for fixed-winged craft. It is an air vehicle which can fly from town to town, completely independent of the huge open spaces essential for aeroplane operation.

More Aerodromes—Yes! But Autogiros where aerodromes are at present impracticable.

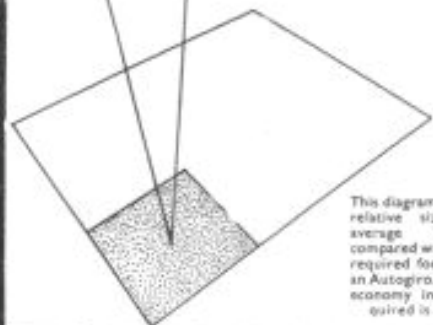

This diagram shows the relative size of an average aerodrome compared with the area required for operating an Autogiro. The great economy in space required is obvious.

**THE CIERVA**  
**AUTOGIRO**  
 BUSH HOUSE, ALDWYCH, LONDON, W.C.2

Aerodrome:  
 LONDON AIR PARK,  
 HANWORTH,  
 Telephone: Feltham 134.

Telephone: Temple Bar 2561.

**Left:** caption: “The practical convenience of air travel will only achieve maximum utility when every town of Importance has its own aerodrome. One of the greatest difficulties in building aerodromes for towns, particularly in industrial districts is the acquiring of large enough areas for operation of orthodox aircraft. The simple solution to this vital problem is the Autogiro. The C.30 P AUTOGIRO can take-off in a few yards, climb steeply over obstructions, descend vertically and land without forward run. It can be operated safely in small areas such as would be impossible for fixed-winged craft . It is an air vehicle which can fly from town to town completely independent of the huge open spaces essential for aeroplane operation. More Aerodromes - Yes! But Autogiros where aerodromes are at present impracticable. This diagram shows the relative size of an average aerodrome compared with the area required for operating an Autogiro. The great economy in space required is obvious.”

***“...Will the airplane of tomorrow develop out of present day ‘brain wave’ designs, so-called because of their freakish departure from generally accepted principles? It is quite possible, as Mr. Miller points out, that the airplane of the future will be entirely different from conventional types we are accustomed to. What will the airplane of the future look like? Will heavier-than-air craft continue to develop along present lines, with refinement of detail, or will something radically different be produced and prove better than existing planes?”***

***Modern Mechanics, October 1930***

***Right: caption: “The Cierva autogiro or ‘windmill’ plane shown above was regarded as a typical freak or ‘brain wave’ design in some quarters when it was first introduced, but it has proved to be a practical flyer which can land in a remarkably small space. The six-story plane pictured at the right is a less successful design. It is the invention of W.F. Gerhardt and was tested at Wright Field, Dayton, Ohio.”***

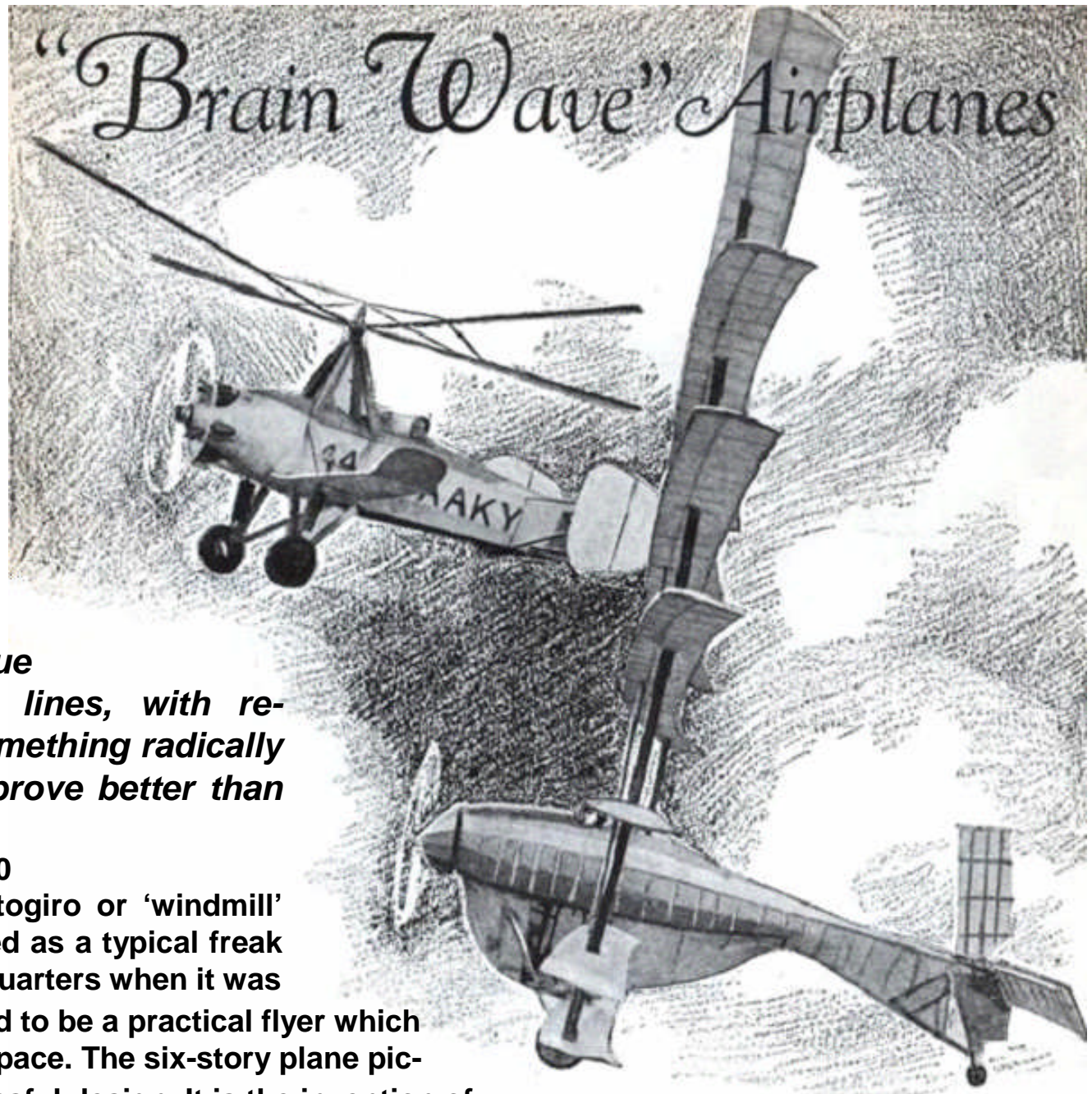

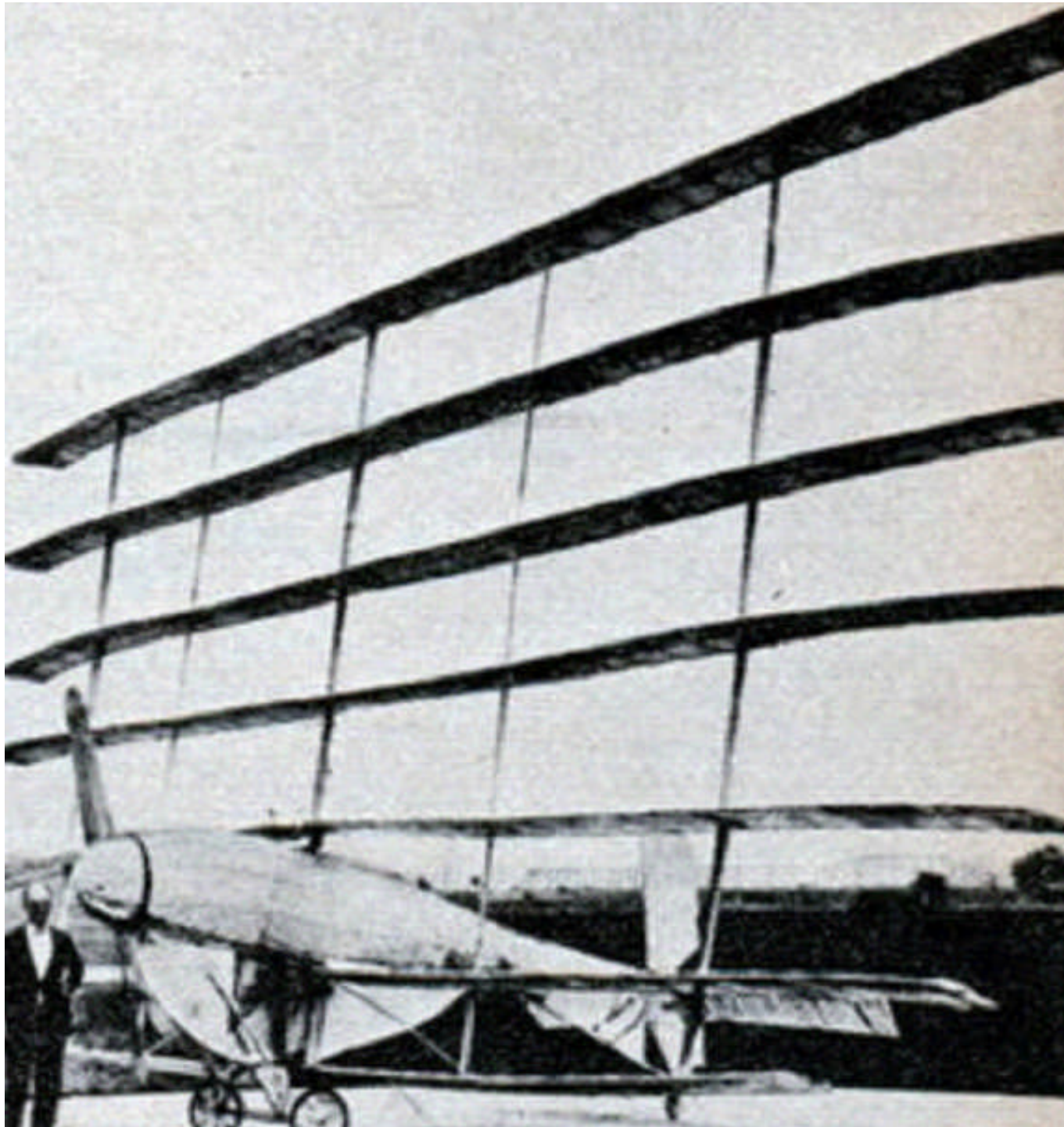

**Left: the six wings of this pedal-powered airplane rose to a height of three inches during its 1923 test flight**



# Parachute Plane

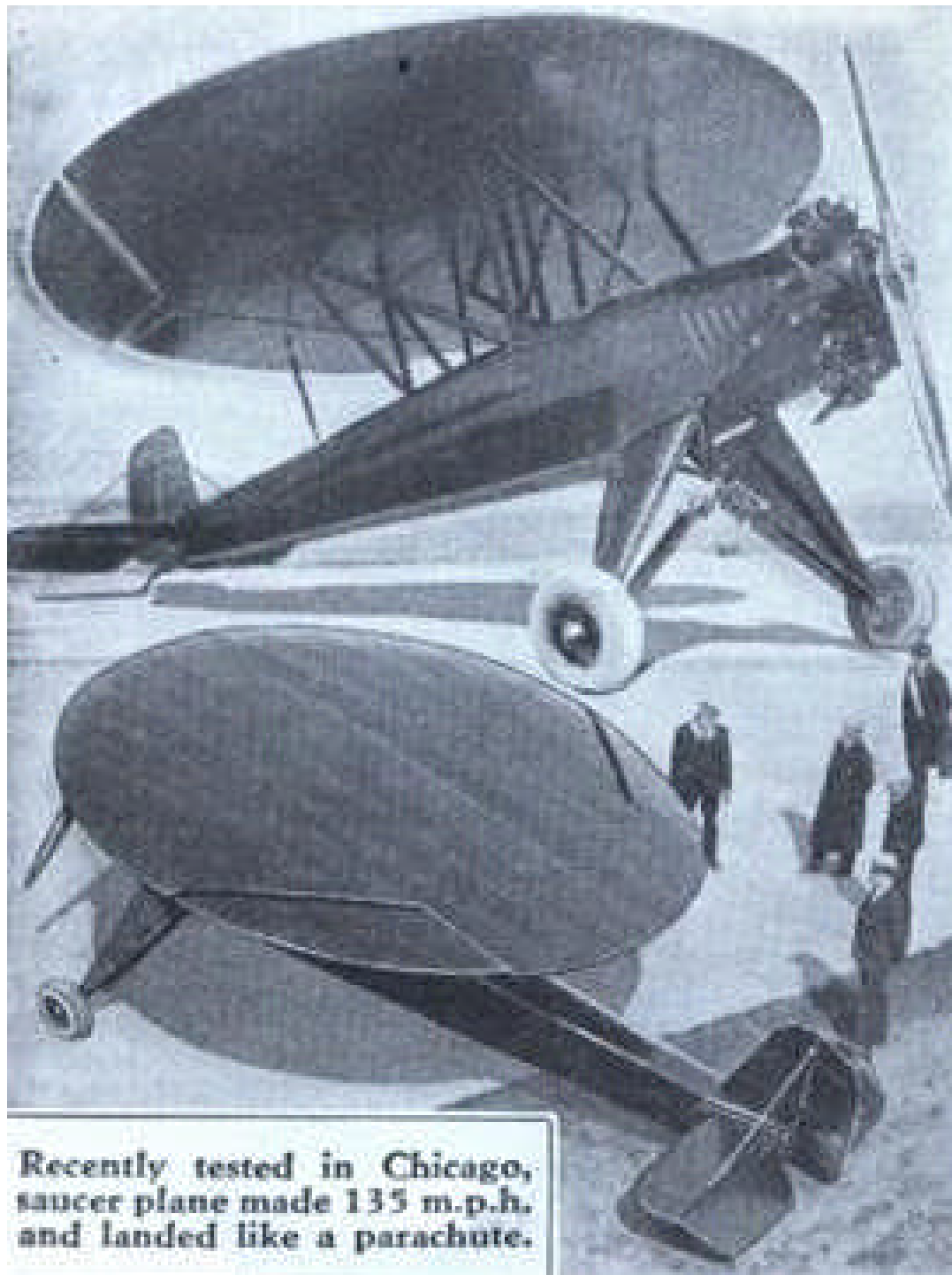

Recently tested in Chicago, saucer plane made 135 m.p.h. and landed like a parachute.

*“First cousin to the autogiro, a new circular-wing airplane recently tested in Chicago is so simple in operation that one who has never been off the ground can learn to fly it in thirty minutes, according to the inventor. Instead of the conventional wing structure, the new plane has a huge saucer-like disc trussed above the fuselage. At the rear of the wing are two ailerons which enable the plane to land at low speeds. A small 110-h.p. Warner motor develops a speed of 135 miles per hour. The ship climbs at an angle of 45 degrees and lands at a speed of 25 miles per hour, coming to a halt within a few feet. The plane’s peculiar fifteen-foot wing is attached to a conventional fuselage by braces like those of the usual high wing monoplane. The ship carries two passengers and can be housed in a hangar not much larger than the ordinary garage. The invention of Steven P. Nemeth, former aeronautics instructor at McCook Field, the plane is virtually stall-proof, foolproof and can land on any kind of field.”*

# **A Plane of the Helicopter Type**

***“...A helicopter could get out of a field the size of its landing gear. It could climb straight into the sky, could hover like a humming bird, and could drop like an elevator descending its shaft. Entirely new realms of aerial travel await the perfection of such a craft. Military observers could dart into the sky, sidestep diving pursuit planes, and plunge to a landing; private ships could be housed in rooftop hangars shaped like water towers; office buildings could be capped with honeycomb cells holding the helicopters of the workers, each craft dropping into its compartment in the morning and rising straight up from it at night; aerial shuttle lines could link centers of population with airports and suburbs...”***

***Popular Science, March 1935***

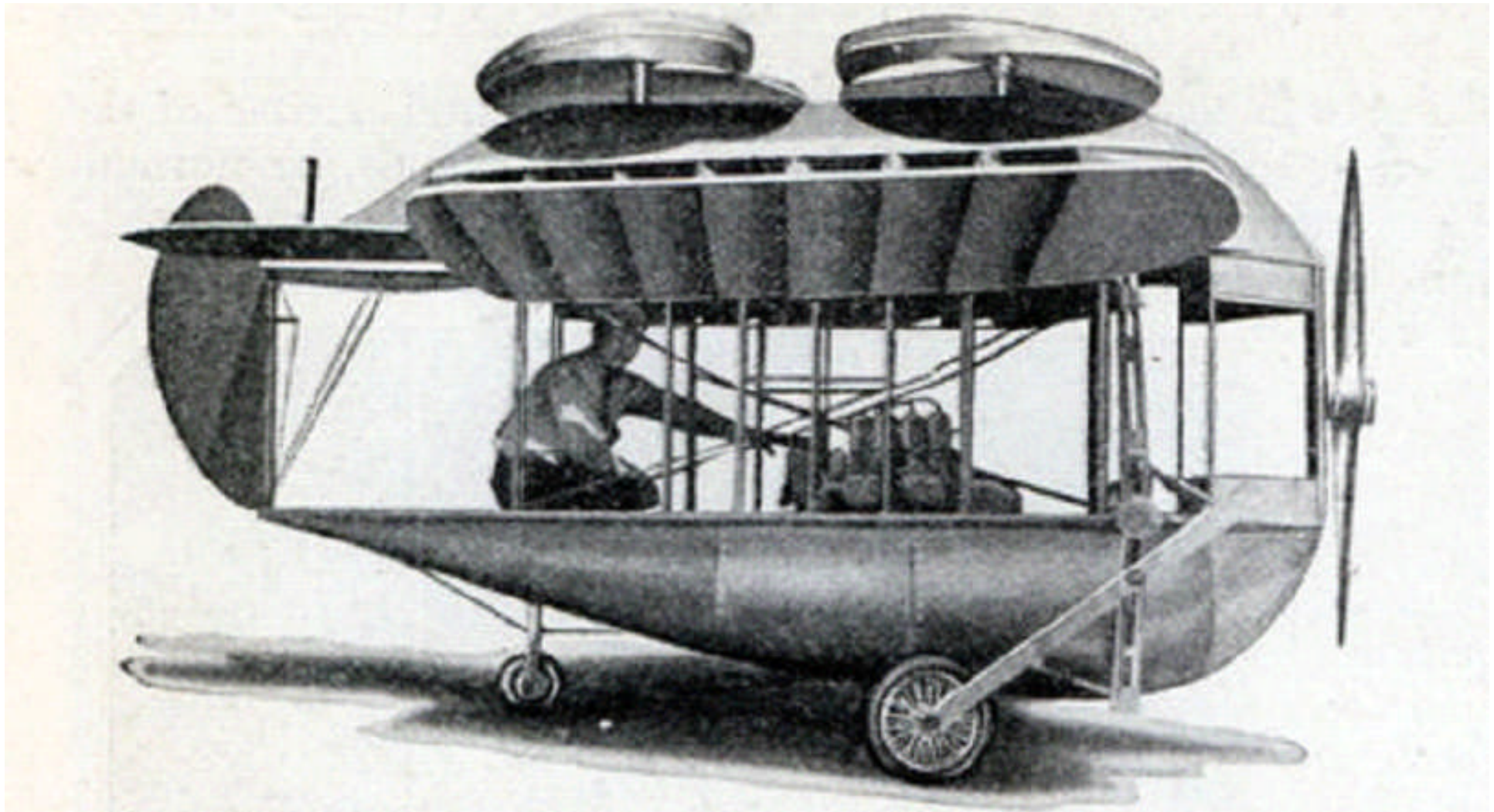

***“The recent success of the Cierva Autogiro has brought forth a deluge of attempts to defeat the law of gravity. Harry Cordy, a Los Angeles inventor, is about to introduce into a startled aviation world a model of his idea of just what an airplane should be. This plane of the helicopter type is characterized by a new form of propeller which is said to produce a superior degree of lift and thus effect a true vertical takeoff or landing.”***

***Modern Mechanics, January 1932***

***Above: caption: “Harry Cordy at the controls of his new helicopter”***

# **Flying Whirligig**

# POPULAR SCIENCE

MONTHLY

MARCH  
15 CENTS  
20 CENTS IN CANADA



NOW  
15¢

20 CENTS IN CANADA

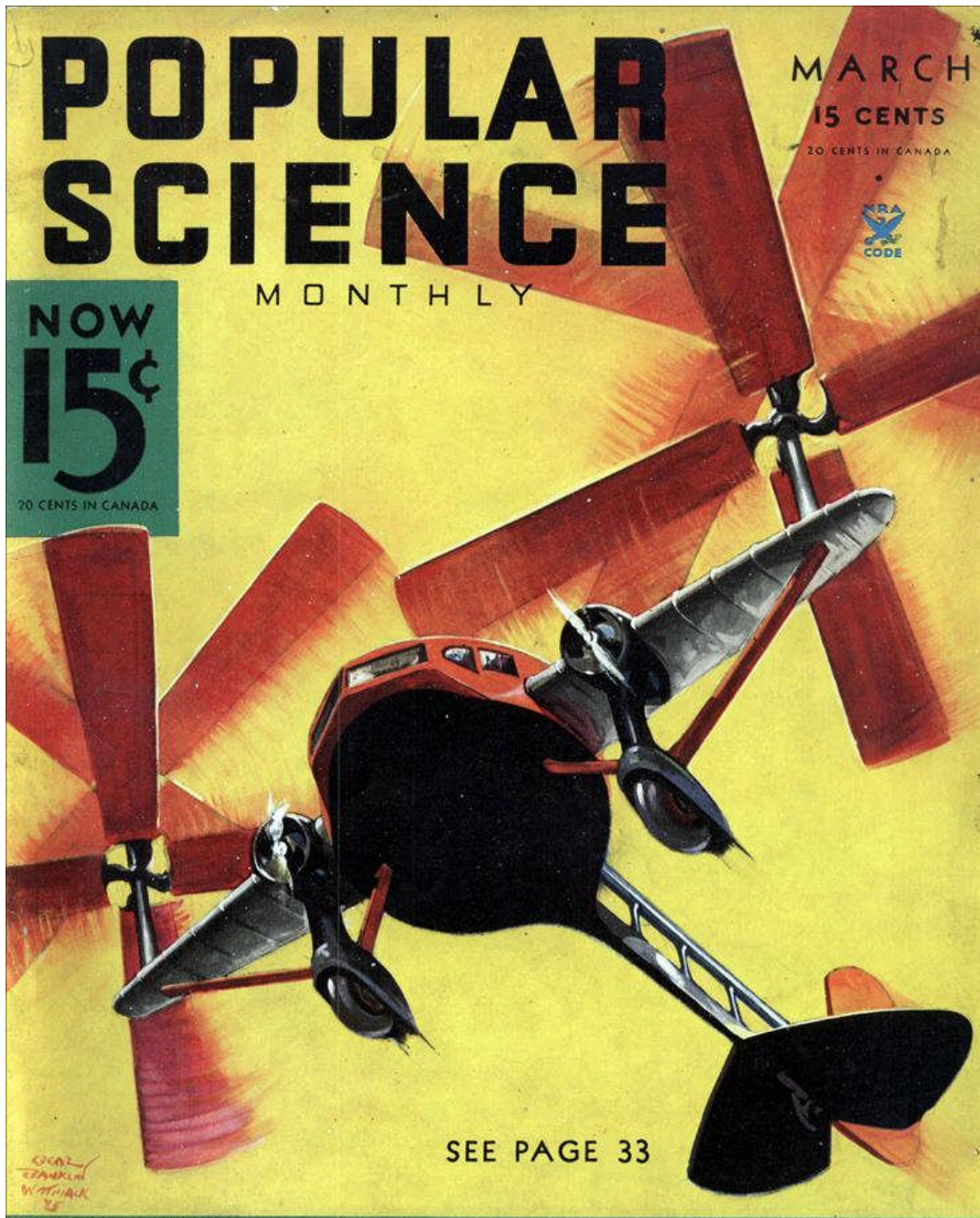

SEE PAGE 33

NEW INVENTIONS • MECHANICS • MONEY MAKING IDEAS  
HOME WORKSHOP PLANS AND HINTS • 350 PICTURES

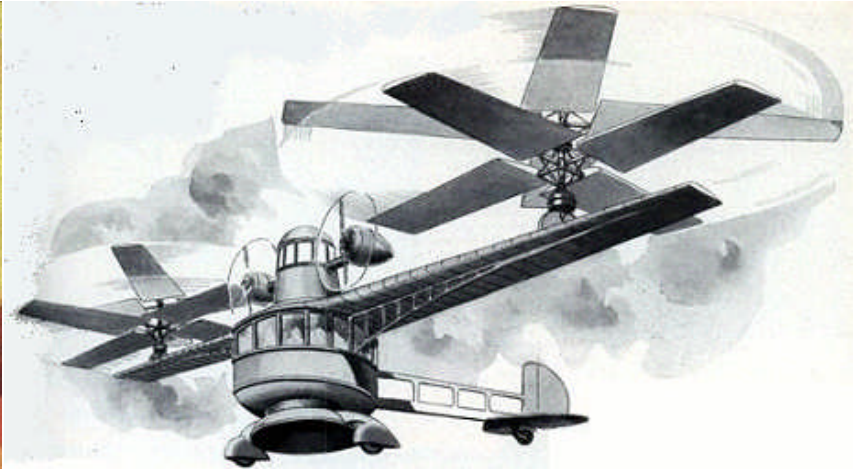

*“A ‘Flying Whirligig’ combining the principles of the standard airplane, the autogiro, and the helicopter, is envisioned by a Glenn Dale, Md., inventor, just granted a patent. His design calls for a main wing of conventional form, having at each extremity a set of windmill-like vanes, or ‘booster-copters,’ arranged to rotate freely when the craft is in motion; their lift aids the main wing to support the machine. The two rotors of each set revolve in opposite directions. Twin propellers, flanking an elevated ‘pilot house,’ constitute its power plant. They swing upward to provide additional lifting force during the takeoff, and return to horizontal position for forward flight. The inventor foresees the construction of huge air liners which could leave the ground or alight in congested areas where space is limited.”*

110

Popular Science, March 1935

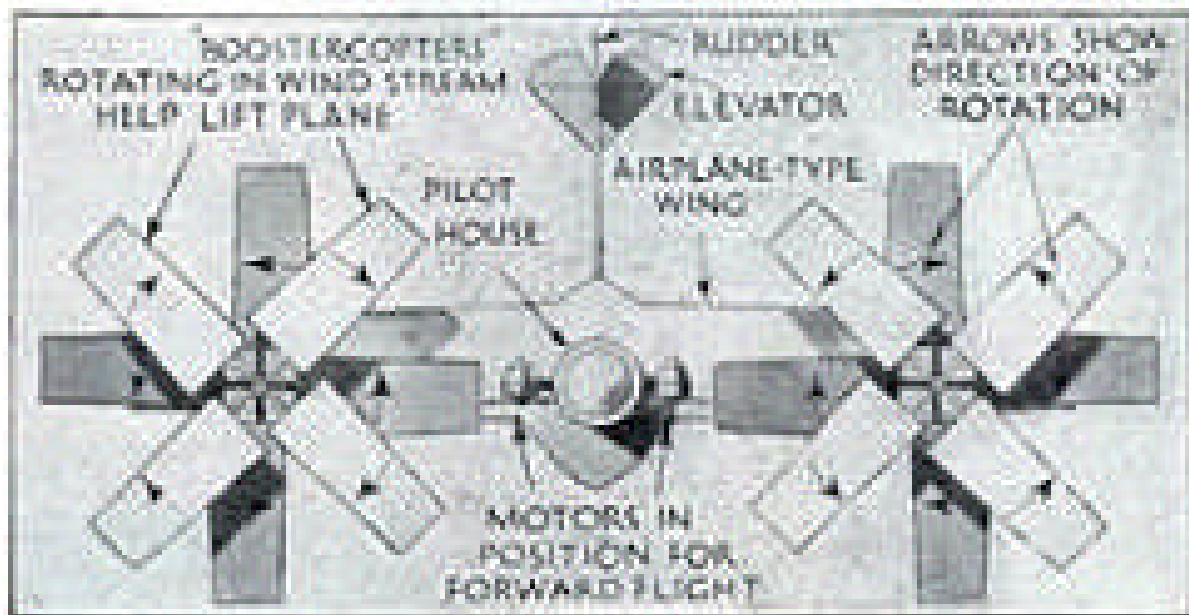

**Left: caption: “Diagram shows how revolving vanes, set near each wing tip, add lifting power and enable craft to alight within a very small space”**



# Spinning Top Plane

# MODERN MECHANIX

AND INVENTIONS

May

NOW  
**15¢**  
IN CANADA 20¢



SPINNING TOP  
PLANE  
SEE PAGE 83



Charles F. Kettering of General Motors Seeks  
**Secret of Hidden Power in Grass**

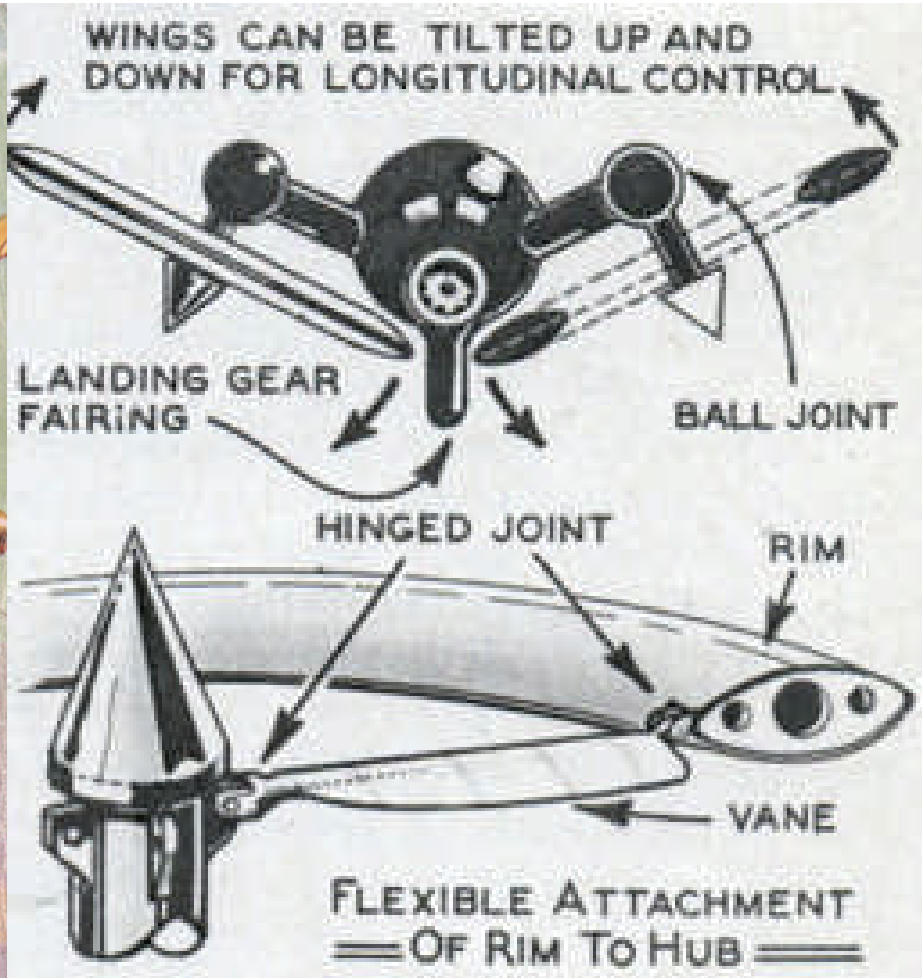

*“The ‘Spinning Top’ plane, illustrated in the drawing above, is the latest idea for the application of the paddle wheel theory being tested abroad. This airship derives its support from rotating wheels which are a compound of an outer rim around rotating vanes. The vanes rotate freely as in the autogiro”*

# **What Next, Flying Cars?**

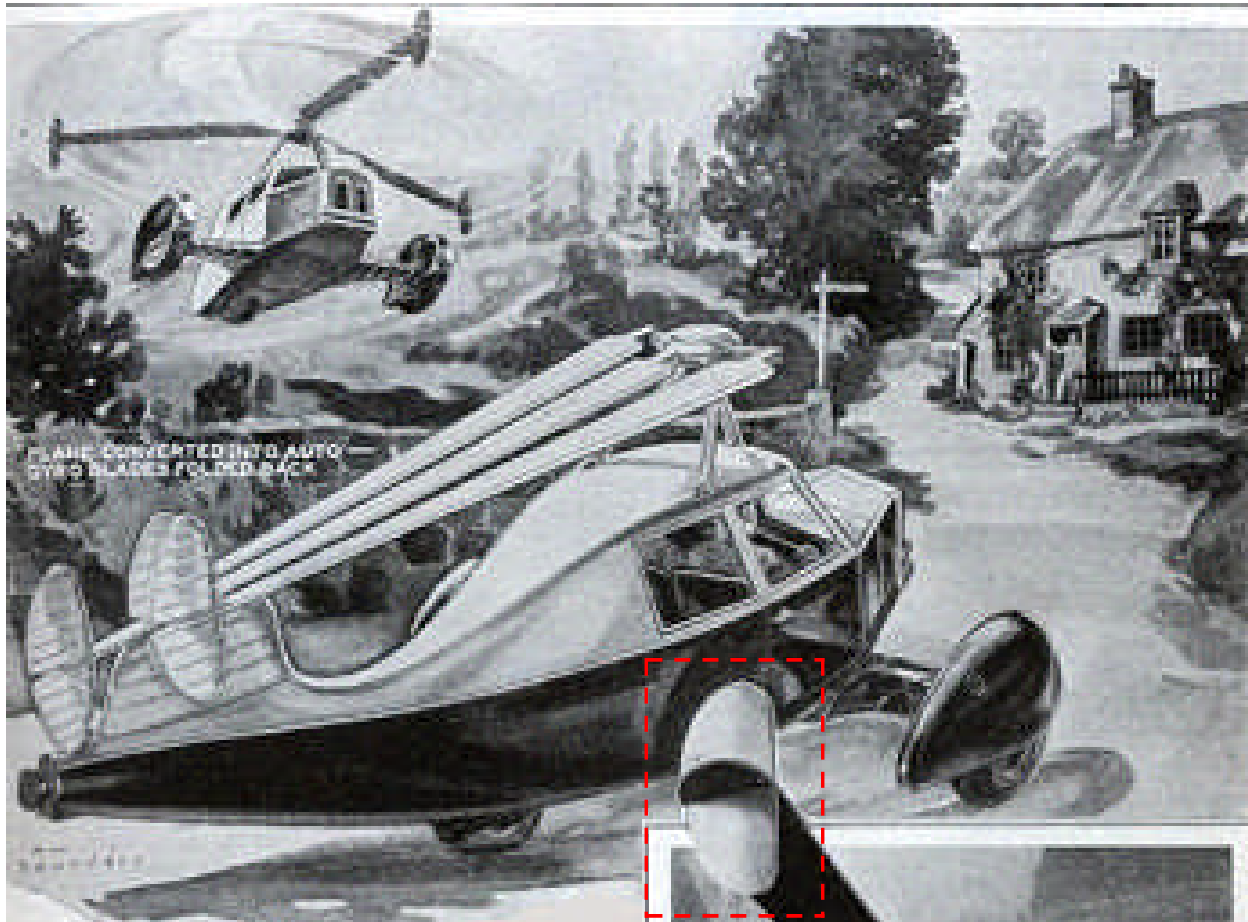

**Above:** caption: "Artist's drawing shows the 'flying auto' doing duty as both plane and auto. When it is to negotiate the highways the gyro blades are disengaged and power applied to the wheels."  
**Right:** caption: "Motor is mounted in the front as in an auto, the power being transmitted from there to either the gyro blades or the front wheels. Forward propulsion of the plane is obtained through action of the little vertical fins on the gyro blades."



**"The 'flying auto,' a combination airplane and automobile which negotiates roads and air lanes with equal facility, has at last appeared in the aeronautical world. Designed by two German engineers, the craft is a development of the autogyro. A great advantage, however, is that no propeller for the drive in the direction of flight is necessary. The little vertical fins on the gyro blades give the necessary force to drive the car forward in the air. When the craft is to be made ready for a trip along the highways the gyro blades are folded back as illustrated in the artist's drawing above. On the road the motor, which is located in the front as an accompanying photo shows, drives the wheels like a regular auto, the steering, however, being done by the rear wheel. Streamlining principles are applied as in a plane, which makes for maximum speed. The 'flying auto' was exhibited at the Berlin airplane show. Some difficulty has been encountered in mounting the engine, so that it is not likely that the plane will soon come into popular use."**

115  
*Modern Mechanix, January 1933*

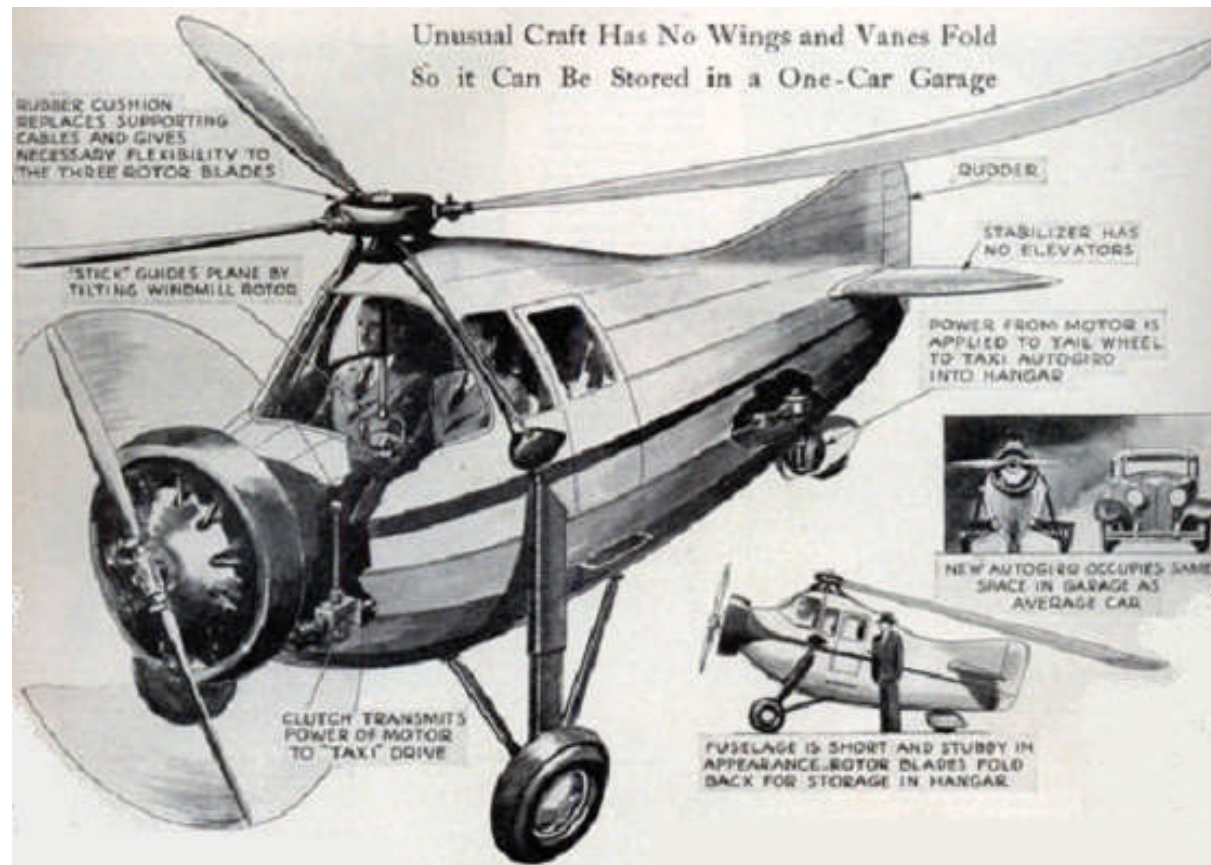

***“Unusual Craft Has No Wings and Vanes Fold So it Can Be Stored in a One-Car Garage. One overhead handle in the cabin of the latest type of autogiro, now being successfully tested and flown at Willow Grove, Pa., enables the pilot to steer up, down, or sideways and to bank the craft simply by tilting the windmill-like rotor. The experimental model carries a horizontal rudder, but tests indicate that this may be superfluous. There are no ailerons or elevators, and the stub wing usually present in this type of craft is missing. Because of the simplicity of control, the new craft is expected to be especially suited to the novice pilot and is soon to be marketed. Other striking innovations are embodied in the new machine. A clutch disconnects the motor from the propeller and transfers the power to a tail wheel, steered from the cabin, so that the plane can run out of its hangar under its own power. The vanes fold out of the way when the plane is stored so it occupies no more space than an auto. It has a top speed of 105 miles an hour.”***

*Popular Science, October 1933*

***Above: caption: “The newest autogiro, as illustration shows, is steered by tilting vanes and runs on ground with power transferred to wheels. Inset illustrations show height of autogiro to be that of a man and its width that of a car.”***



***“The wing-less autogiro and the invention of a combined land and air drive makes the dream of the flying auto come true. Flying automobiles are within reach of the public today as a result of a dual drive for land or air invented by Edward A. Stalker, of Ann Arbor, Mich. His gear drive includes a simple clutch which engages a wheel to drive the car on land or a propeller to push the vehicle through the air...”***<sup>117</sup>  
***Modern Mechanix, July 1935***

**“...Based on this invention, the giro-automobile was designed. In appearance it resembles the modern streamlined, rear engine automobile. No wings are necessary as autogiro blades would provide the necessary lift. The U.S. Bureau of Air Commerce has ordered the Pitcairn Autogiro Company to design an autogiro airplane-automobile for amateur fliers, which with its rotor blades folded back and its engine geared to the wheels that can be driven on a highway like a motor car.”**

**Modern Mechanix, July 1935**

**Inset Lower Right:** caption: “Drive wheel A in diagram would propel flying auto-moblie on land. To take off giro blades are started spinning and drive wheel runs the car for short distance needed for auto giro takeoff. In flight, wheel would drop, engaging shaft C which drives propeller for forward flight.

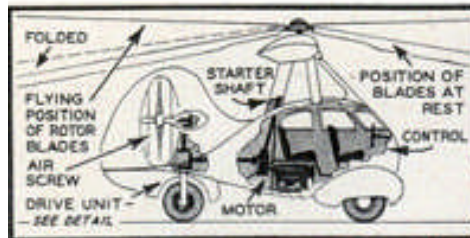

Sectional diagram above shows how Stalker's dual drive system would be used in giro-auto.

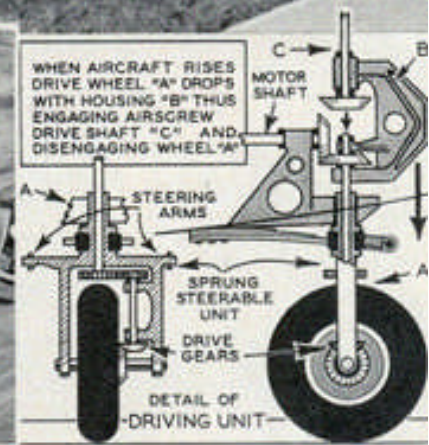

**Above:** caption: “Photos show latest Pitcairn autogiro.

10¢ **BILL BARNES** OCTOBER 1935  
**AIR TRAILS**

A  
GREAT FEATURE  
BY  
**CLYDE  
PANGBORN**



FEATURES - FACTS - MODELS - HOWS - PLANS - DEVICES - AIR STORIES  
MARK OF THE VULTURE - Bill Barnes Air-Naval Co. George E. Eaton  
Clyde Pangborn - Albert J. Carlson - Gordon E. Light - Frank J. Taylor - Arno Wittmann



*“...after sixteen years the autogiro has only now become an autogiro...”*

*Fortune magazine, March 1936*

RE: the “roadable” autogiro had been a *Pitcairn Aviation* project for the *Bureau of Air Commerce* under the leadership of *Eugene Vidal*. *Pitcairn’s* chief test pilot *Jim Ray* had previously delivered the *Pitcairn AC-35* to the Federal Government by landing it in a *Washington D.C.* park, folding its blades back, and driving it through the streets (above). The roadable autogiro did receive media attention appearing in several publications (left), but failed to excite the public-at-large who saw it as a novelty rather than a practical conveyance.



# **Convenient for the Absent-Minded**

Sees storm ahead - slows down to 20 m.p.h. to choose his landing spot (which need not be more than 100 feet square)

A few minutes later he lands on a friend's lawn to take him to the city.

Leaving filling station he proceeds to nearest open lot, unfolds the rotor blades and jumps off.

100 miles from the city the owner tells his giro out of its garage and drives it along road to the nearest filling station.

Stern having passed he takes to the air and attains top speed of 110 m.p.h.

Lands on lot close to city and drives giro through streets to his office, or he may land on roof of his building if suitable.

Thus the giro commuter might make the 100-mile trip to his office in one appreciably less than that of a light car.

Municipal airport 3 miles from the center of town usually a 20 to 30-minute ride by bus or car.

Note relative storage space required for giro and conventional 2-seater plane.

### The AIRPLANE counteracts Force with Force, resulting in Stress

### The AUTOGIRO counteracts Force with Force, resulting in Equilibrium

The rotor of a giro is not a propeller. It is a revolving wing and its rotation while in flight is independent of the engine.

#### HOW IT WORKS -

1. Before the giro takes off, the rotor is set spinning by the engine which is thereafter disengaged.
2. This rotation sets up two elementary forces -  
 (A) Centrifugal Force, which keeps the rotor blades extended.  
 (B) Lifting Action, by the rotor, whose blades act in relation to the air like airplane wings in motion.
3. As soon as the ship is in the air a third force (C) comes into play. This is the pull of Gravity, exerted by the ship which hangs from the rotor hub. - Since Centrifugal Force (A) prevents the blades from folding upward, their only escape from the conflicting actions of (A), (B), & (C) is to continue to rotate. - See diagrams.

#### AUTOGIRO ANATOMY

Rotor hub  
 Direct control stick (see upper right)  
 Gear box, main clutch to propeller shaft to rotor transmission  
 30 H.P. Polysyn motor, 12 ft. diameter, 1000 r.p.m. - 1000 r.p.m. - 1000 r.p.m.  
 Main shaft  
 Gear drive shaft  
 Propeller  
 Rudder, horn action and steering doubles (actuated by gear roll in direct ruddery)  
 Two propellers, rotating in opposite directions to nullify torque, which multiple-propeller ship is denuded by using surfaces and airfoil manipulation.

1. If you were dropped from a height without first spinning the rotor this would happen (Gravity only force operative) and it would drop like a dead duck.

2. DIRECT CONTROL & HOW IT WORKS - The rotor is so attached that the pilot can tilt it in any direction with respect to the ship. A tilt to the right, for example, increases lift on the left, causing a bank and then a side-slip to the right. Since the tail resists side-slip, the fuselage turns to the right.

3. Force (C) (gravity) acts upward on blade.

4. Force (B) (lift) acts upward on blade.

5. Force (A) (centrifugal), developed by the tip speed of 200-400 m.p.h. keeps blade from folding upward.

6. If you were dropped from a height without first spinning the rotor this would happen (Gravity only force operative) and it would drop like a dead duck.

7. when giro is moving forward, the advancing blade meets the air at greater or steeper than the retreating blade. This would result in greater lift on the advancing side were it not that the advance in a blade automatically rises at its hinge and the resulting angle decreases its lift. As it swings around to the retreating side - it hits the air at a steeper angle, down again and increases its lift.

Overall Dimensions:  
 Height 8 feet  
 Width 7 feet  
 Length 19 feet  
 Weight 1250 pounds full, 750 pounds empty

Richard Harwood

**YOU CANNOT DO THIS YET**  
 and it may be many a day before you can. But the reborn autogiro, described in the accompanying text, is designed to make possible the commuter's itinerary pictured around these two pages. The new two-passenger ship, to be demonstrated this spring, will weigh 750 pounds empty and be narrow enough of beam, when rotor blades are folded back over the tail, to be stowed in an ordinary garage and not to be a road hog on the highways. It will have a top speed in the air of 110 miles per hour, twenty five on wheels. The 'roadable' mechanism consists of a small transmission and a shaft to the rear wheel from the engine, which is mounted inside the cabin, abaft the seats. A clutch disengages the propeller for road touring. The front wheels are steerable, operated by the rudder pedals. The pilot will use the same motions for steering on the ground as in the air, which should be convenient for the absent-minded."

ANATOMY OF AUTOROTATION  
 In the diagram on the left we set both the principle underlying why and how an autogiro flies (for an exhaustive treatise see Fournier, March, 1934). The rotor samples in the product of three men in development, each sharply misnamed by an inventor. First step, speed. Clava separates the speed of the mechanical lifting surface from the speed of the machine as a whole. That is, the ability to maintain flight was made independent of high forward speed. Lift's source is an ordinary airplane diagram (item 1) to 1000 ft. high wings (1934). Clava separates control, steering, landing, climbing, gliding from forward speed. Control is welded to lift, and lift is constant at all speeds from 0. Third step, speed. Clava achieves direct take-off by storing up surplus energy in the rear by oversteering it on the ground. To the ability to stop gently down a new joined the ability to take off with no forward run.

**“YOU CANNOT DO THIS YET...and it may be many a day before you can. But the reborn autogiro, described in the accompanying text, is designed to make possible the commuter’s itinerary pictured around these two pages. The new two-passenger ship, to be demonstrated this spring, will weigh 750 pounds empty and be narrow enough of beam, when rotor blades are folded back over the tail, to be stowed in an ordinary garage and not to be a road hog on the highways. It will have a top speed in the air of 110 miles per hour, twenty five on wheels. The ‘roadable’ mechanism consists of a small transmission and a shaft to the rear wheel from the engine, which is mounted inside the cabin, abaft the seats. A clutch disengages the propeller for road touring. The front wheels are steerable, operated by the rudder pedals. The pilot will use the same motions for steering on the ground as in the air, which should be convenient for the absent-minded.”**

## “ANATOMY OF AUTOROTATION...

In the diagram at right are set forth the principles underlying why and how an autogiro flies...The reborn autogiro is the product of three steps in development, each sharply mile-marked by an invention. First step, 1920-23: Cierva separates the speed of the mechanical lifting surfaces from the speed of the machine as a whole. That is, the ability to maintain flight was made independent of high forward speed,

life's breath to an ordinary airplane (diagram items 1 to 10). Second step, 1932-34: Cierva separates control – steering, banking, climbing, gliding – from forward speed. Control is wedded to lift, and lift is constant at all speeds (item 7). Third step, 1934-35: Cierva achieves direct take-off by storing up surplus energy in the rotor by overspeeding it on the ground. To the ability to take off with no forward run.”

*The AIRPLANE counteracts Force ~ with Structure, resulting in Stress*  
*The AUTOGIRO counteracts Force ~ with Force, resulting in Equilibrium*

The rotor of a giro is not a propeller. It is a revolving wing and its rotation while in flight is independent of the engine.

**HOW IT WORKS :-**

1. Before the giro takes off, the rotor is set spinning by the engine which is thereafter disengaged.
2. This rotation sets up two elementary forces :-  
 (A) **Centrifugal Force**, which keeps the rotor blades extended.  
 (B) **Lifting Action** by the rotor, whose blades act in relation to the air like airplane wings in motion.
3. As soon as the ship is in the air a third force (C) comes into play. This is the pull of Gravity, exerted by the ship which hangs from the rotor hub. Since Centrifugal Force (A) prevents the blades from folding upward, their only escape from the conflicting actions of (A), (B), & (C) is to continue to rotate. See diagrams

**THE ROTOR**  
 hinges permitting upward motion  
 hinges permitting lateral motion  
 weight of ship hangs from hub

**7. DIRECT CONTROL & HOW IT WORKS:-**  
 The rotor is so attached that the pilot can tilt it in any direction with respect to the ship. A tilt to the right, for example, increases lift on the left, causing a bank and then a side-slip to the right. Since the tail resists side-slip, the fuselage turns to the right.

**4. Force (C) (gravity)**  
**5. Force (B) (lift) acts upward on blade**  
**6. Force (A) (centrifugal) developed by the tip speed of 200-400 m.p.h. keeps blade from folding upward.**

**8. If giro were dropped from a height without first spinning the rotor this would happen (Gravity only force operating) and it would drop like a dead duck**

**9. but with initial rotation (hence Centrifugal Force & Lift) the blades keep on spinning till the giro settles to earth (at a speed less than that of a parachute)**

**10. when giro is moving forward, the advancing blade meets the air at greater speed than the retreating blade. This would result in greater lift on the advancing side were it not that the advancing blade automatically rises at its hinge and the resulting angle decreases its lift. As it swings around to the retreating side, it hinges down again and increases its lift.**

**AUTOGIRO ANATOMY**

Drive shaft to rotor (used only in starting)  
 Direct control stick (see upper right)  
 Gear box, contains clutch to propellers, clutch to rotors & transmission gears  
 Rotor hub  
 Mechanism for jump take-off (see text and photos for explanation)  
 90 H.P. Pobjoy motor, 7 cyl. air-cool. d. radial type. location in rear improve viability.  
 luggage space  
 fuel tank  
 road drive clutch  
 Two propellers, rotating in opposite directions to nullify torque, which in single-propeller ships is damped by wing surfaces and aileron manipulation.  
 Brakes, knee action and steering knuckles (castered to permit roll in dirt landings)  
 Rudder: not essential but permits shorter turns  
 Box-like structure to stabilize the fuselage in light and support rotors at rest  
 rotors tilted back for road travel  
 Drive shaft to single rear wheel for travel on road

Overall Dimensions:  
 Height 8 feet  
 Width 7 feet  
 Length 19 feet  
 Weight -1250 pounds full, 750 pounds empty

Richmond Harrison

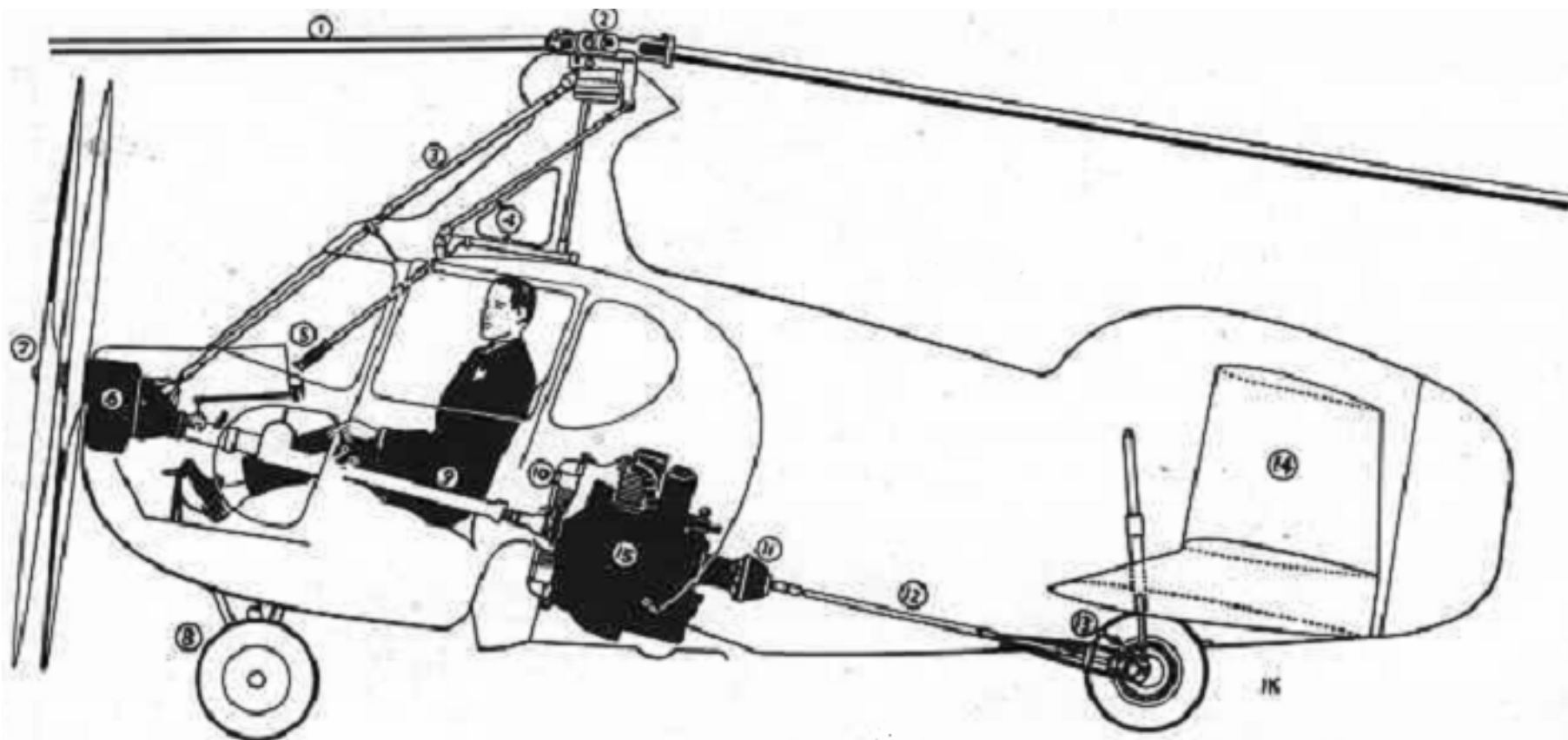

- ① ROTOR BLADE (FOLDS FOR ROAD USE)
- ② ROTOR HEAD
- ③ ROTOR STARTER DRIVE SHAFT
- ④ LINKAGE FOR "DIRECT CONTROL" ROTOR TILTING
- ⑤ GRIP THROTTLE ON STICK
- ⑥ GEAR BOX WITH PROPELLER CLUTCH, ROTOR STARTER CLUTCH, PROPELLER GEARS
- ⑦ TWIN PROPELLERS (OPPOSITE ROTATION)

- ⑧ STEERABLE KNEE ACTION FRONT WHEELS
- ⑨ DRIVESHAFT TO PROPELLER GEAR BOX
- ⑩ ENGINE COOLING FLYWHEEL FAN
- ⑪ CLUTCH FOR ROAD DRIVE
- ⑫ DRIVESHAFT TO SINGLE REAR WHEEL
- ⑬ FREE WHEELING GEAR FOR ROAD DRIVE
- ⑭ BOXLIKE FIXED TAIL STRUCTURE
- ⑮ MOTOR IN REAR IMPROVES VISIBILITY

**Above:** caption: "Pitcairn AC-35 drive and control diagram. Note two contrarotating propellers. The dual propeller feature was abandoned in favor of a large single propeller because a report says, 'Propellers set up a howl that could shatter glass.'" 123







***“Jess Dixon, of Andalusia, Ala., got tired of being tied up in traffic jams, so he designed and built this novel flying vehicle. It is a combination of automobile, helicopter, autogiro, and motorcycle. It has two large lifting rotors in a single head, revolving in opposite directions. It is powered by a 40 h.p. motor which is air-cooled. He claims his machine is capable of speeds up to 100 miles an hour.”***

***Mechanix Illustrated, November 1941***

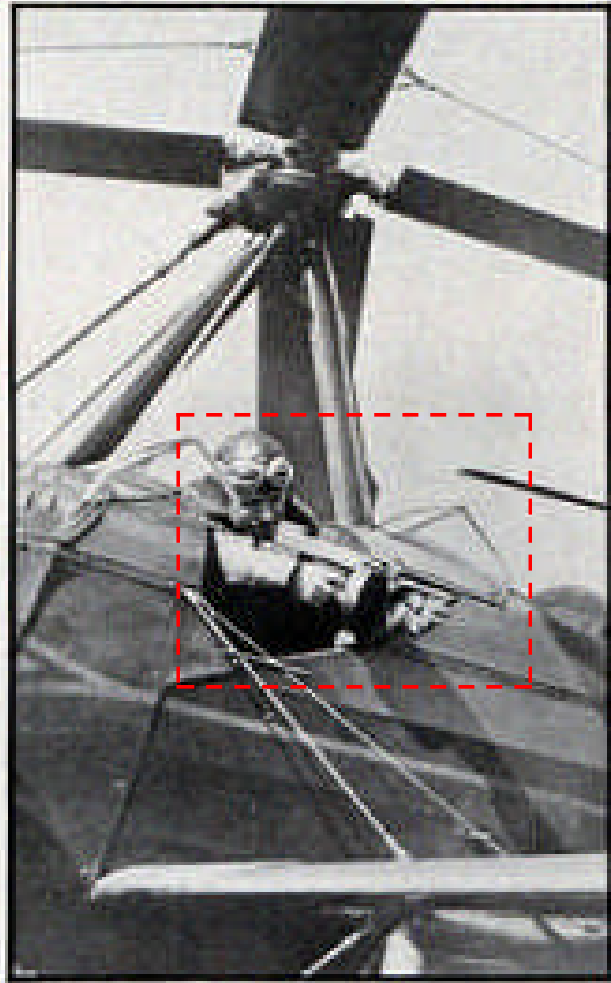

***To test an autogiro in a motor bandit chase, a driverless car recently was sent speeding across a field near Bryn Athyn, Pa. A windmill plane took off in pursuit, carrying Chief of Police Theodore Hollowell.***



***Using a sub-machine gun, as at left, he peppered the car until a direct hit disabled it. Tracer bullets set the car afire. The end of the chase is shown below, with the autogiro about to land.”***

***Popular Science, 127  
June 1933***





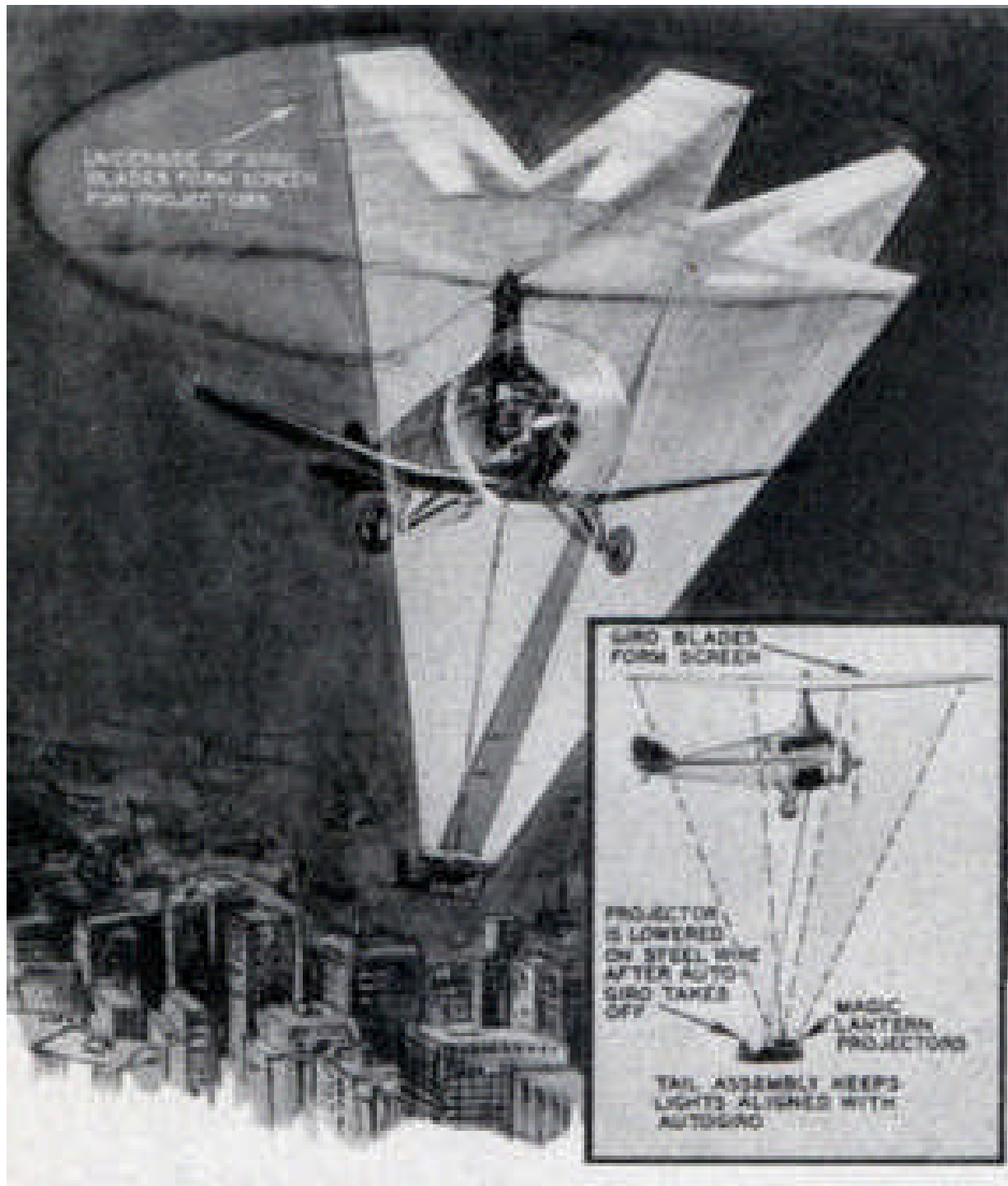

*“Display advertising at night by means of a magic lantern suspended beneath an autogiro, with the rotating blades serving as a screen, is a German inventor’s latest medium for placing a product before the public eye. The magic lantern assembly is placed in a torpedo shaped carriage equipped with vertical and horizontal rudders to keep it in perfect alignment with the autogiro flying above. It can be raised or lowered by means of a cable, for focusing the advertiser’s message on the blades. When landing, the projector is drawn up into the fuselage. To insure perfect reproduction of the advertisement, the under sides of the rotor blades are specially treated. The autogiro has been found to be particularly adapted for this type of aerial advertising because of its ability to hover almost motionless in the air, while the blades revolve fast enough to form an uninterrupted screen.”*

*Modern Mechanix, September 1935*

**Left:** caption: “Hovering almost motionless in the air, this autogiro, equipped with magic lanterns, can present aerial advertisements at night by using the rotating blades as a screen.”

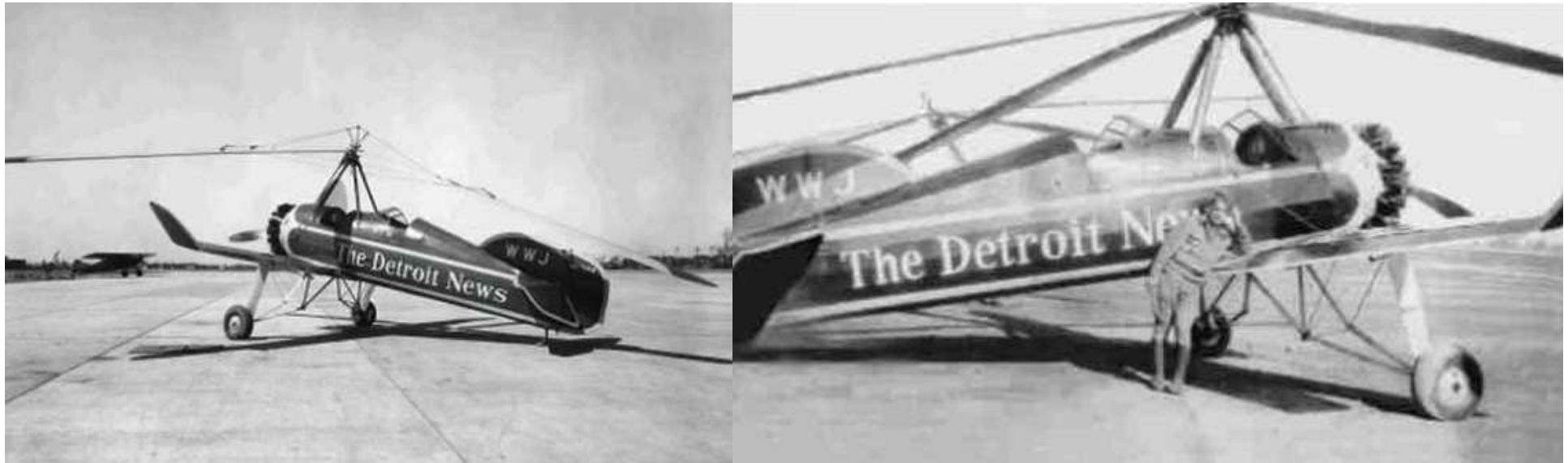

***“With a huge aerial camera mounted in the front cockpit, a three-place auto-gyro has been added to the facilities of the Detroit News. The plane was selected because of its ability to land and take off in small and restricted areas, to fly at slow speed once in the air, as is oftentimes necessary in news photography, and because it can ‘hover’ over selected spots for short periods. The plane will descend vertically at parachute speed.”***

***Popular Mechanics, October 1931***

***Above:*** the *Detroit News* Autogiro was a standard *Pitcairn PCA-2*, powered by a *Wright 300* horsepower *J-6* engine, painted in the *Detroit News* colors (red and ivory), with the name on the sides and underbody of the plane and call letters *WWJ* of the News’ radio station painted on the vertical fin. In the forward cockpit special arrangements were made for mounting a large *Fairchild* aerial camera on a swivel mount and an auxiliary raised seat was provided for a photographer when operating the camera. It was delivered to Detroit on Feb. 15<sup>th</sup> 1931 and represented the first commercial use of an Autogiro.



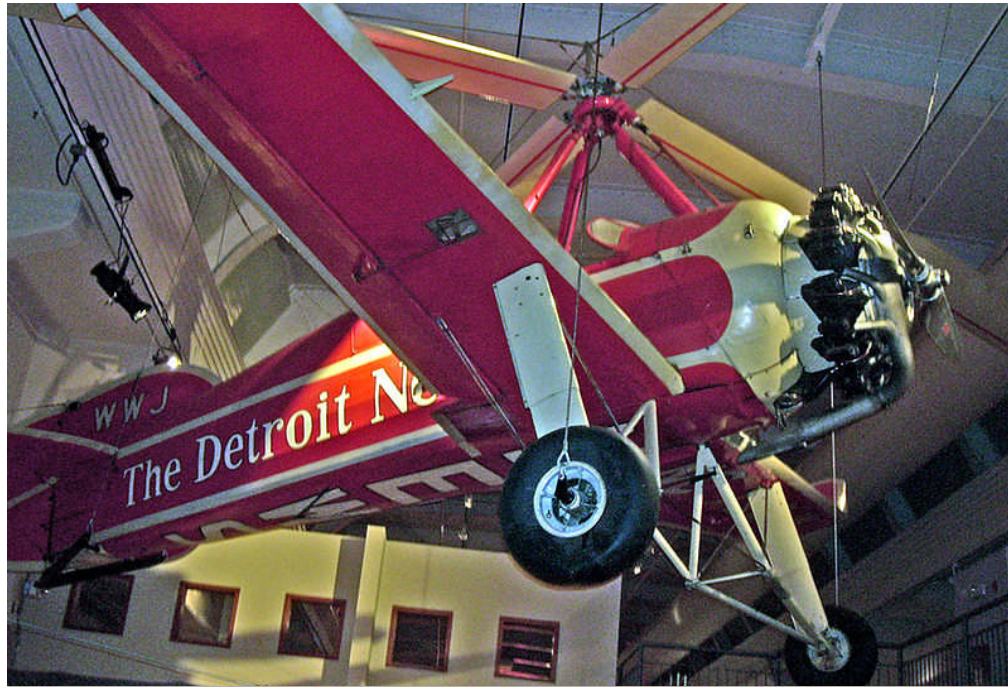

# **The Most Modern Means of Transportation**

***“...the most modern means of transportation at the command of the civilized world...Modern business demands action and a first-hand knowledge of what is going on throughout the country. The day is past when you can run a business from behind a desk...”***

***The Wichita Beacon, October 15<sup>th</sup> 1931***



***Robert Wood Johnson*** (left), VP of ***Johnson & Johnson*** of ***New Brunswick, N.J.***, was so interested in aviation that at one point in the 1920s he bought a biplane and flew it around the New Brunswick area. In a newspaper interview he said that he was thinking of providing airplanes for all of the company salesmen so they could save time and improve their performance. Johnson developed his own prototype amphibious biplane, but while taking off from the bay at ***Keyport, N.J.*** on its second test flight and flying to New Brunswick for its first runway landing, a wheel strut snapped during the landing. The plane skidded down the runway, flipped onto its back and skidded to a crash stop. Miraculously, the pilot was unhurt, but the plane was destroyed thus ending Johnson's hopes of bringing a new industry (and jobs) to New Brunswick.

---

# ROBERT W. JOHNSON TAKES U. S. TESTS

---

## First in This Section to Receive Private Opera- tor's License

---

Robert W. Johnson, vice president of the local manufacturing concern of Johnson & Johnson, received his private autogyro operator's license at Hadley Airport yesterday afternoon from Inspector George D. Ream of the Aeronautics Branch, U. S. Department of Commerce.

The autogyro operator's license awarded to Mr. Johnson yesterday was the first ever issued at Hadley Airport and the first received in this territory, including Middlesex county.

*"In order to cover the territory as rapidly as possible, yet spend sufficient time in each city, Mr. Johnson is making the entire trip by air, using his auto-gyro so that landings can be made in places ordinarily inaccessible to the regular type plane."*

*The Wichita Beacon, October 11<sup>th</sup> 1931*

RE: R.W. Johnson soon became interested in autogyros, and he began taking lessons on how to pilot them. He was awarded an autogyro pilot's license – the first nonprofessional autogyro pilot's license in the region (he had License No. 1), and the first one in *Middlesex County, N.J.* Johnson eventually bought a *Pitcairn* Autogyro and was soon using it for business travel, because it was a quick and efficient way for him to get around. During the depths of the *Great Depression* the company was looking for ways to improve business. So it was that in 1931 *Robert Wood Johnson* announced that he would visit sixteen mid-western cities in which there were major wholesale customers in a little over two weeks. To save time, he would use his Autogyro. In 1932, Johnson used his Autogyro to visit *Montreal*, where *Johnson & Johnson* had a subsidiary.



## HERE'S HOW HE CHECKS UP ON BUSINESS

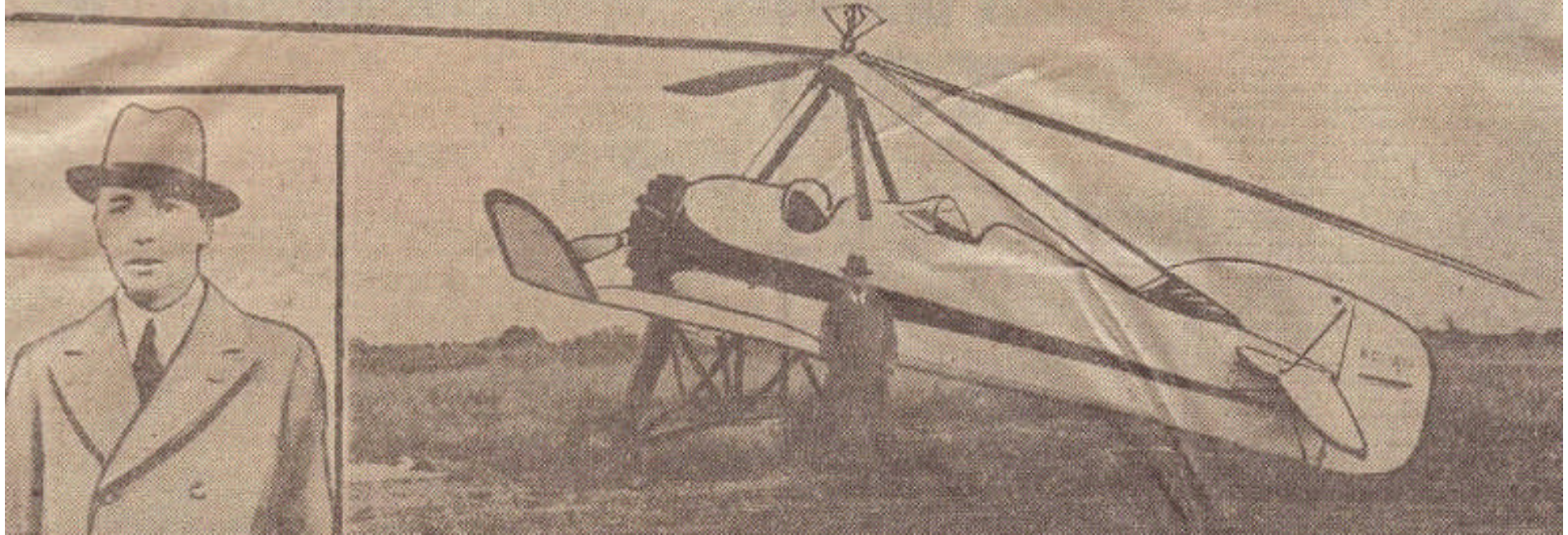

**Johnson was well known for making surprise inspections at company facilities. Many times, the local manager would receive advance word of the surprise inspection and employees at the facility would race around hiding clutter and making sure that everything was up to Johnson's exacting standards. The manager at one site decided to store some materials on the roof to get them out of sight during Johnson's visit. Unfortunately, Johnson came in by air that day and the first question he asked the nervous manager was: "what is all that stuff doing on your roof?"**

# **Lady Lindy's Grand Tour**

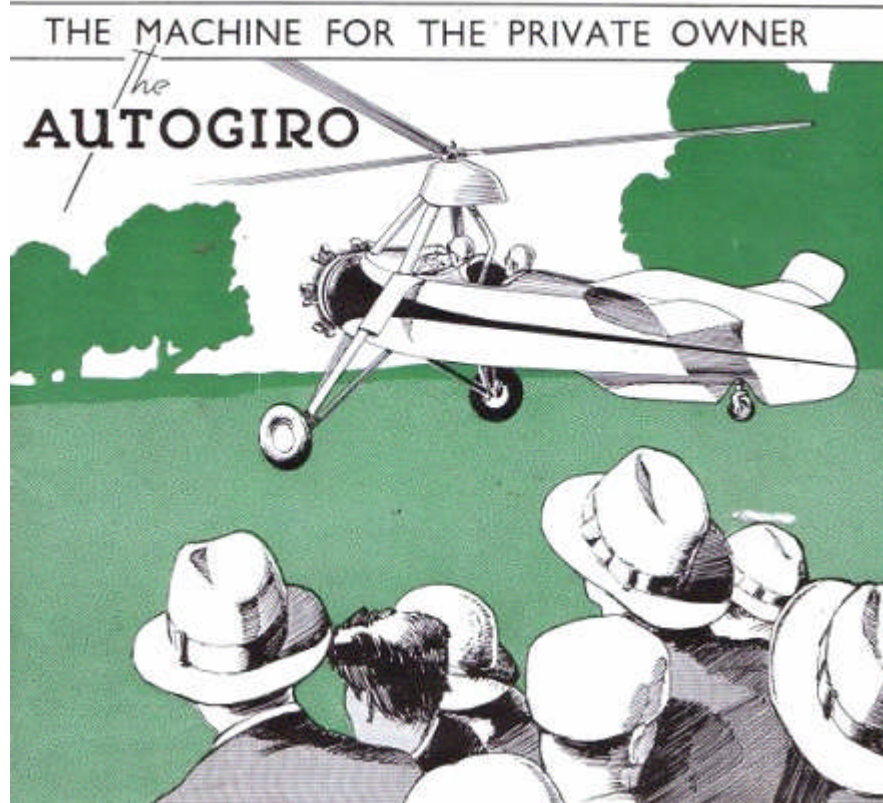

By 1930, famed aviatrix *Amelia Earhart* became interested in the Autogiro. She had, after a single 15-20 minute flying lesson by Pitcairn factory test pilot *John Paul "Skipper" Lukens*, soloed at the *Pitcairn Aviation* field at *Willow Grove, PA* on December 19<sup>th</sup> 1930, thus becoming the first female Autogiro pilot. Advertising for the Autogiro was just beginning and Pitcairn's offices received deposits and advanced orders from individuals and corporations seeking the convenience, safety and publicity that seemed to accompany almost every Autogiro flight.



**Above:** caption: “Amelia Earhart, transatlantic aviatrix, with her husband, George Palmer Putnam, Jr., the publisher, left, and Harold Pitcairn, the airplane designer”

**Left:** *Amelia Earhart* - the aviatrix who earned fame in 1928 as “Lady Lindy” (the first woman to fly across the *Atlantic*) loved flying and kept at it, piloting a *Lockheed Vega* to third place in the first *Women’s Air Derby* in 1929 and setting three women’s world speed records in June 1930. In February 1931, she married publisher *George Putnam* who ordered an *Autogiro* for his new bride.<sup>139</sup>



***Amelia Earhart* increased speed for take-off from Pitcairn's *Willow Grove* field one fine day in December 1930. Soon she was sailing over the snowy *Pennsylvania* fields, practicing take-offs and landings under the watchful eye of her tutor *James Ray* - test pilot for the *Pitcairn Autogiro Company*. After bringing the Autogiro in for a final landing that day, Earhart admitted she didn't know "whether I flew it or it flew me."**

**Above L&R: caption: "Willow Grove, PA - December 18, 1930. Amelia Earhart after becoming the first woman to fly solo in an autogiro"**



**While waiting for her own *Pitcairn Autogiro* to arrive, Earhart borrowed a company model for practice flights. On April 8<sup>th</sup> 1931, she donned a heavy flying suit, boots and mittens to fly Pitcairn's *PCA-2* model. Planning to test the autogiro's ceiling, she carried an oxygen bottle and arranged for the *National Aeronautic Association* (NAA) to install a sealed Barograph in the *PCA-2*. Putnam, hoping she would do something newsworthy, invited members of the *New York* press and *Movietone News* to watch. The crowd of nearly five-hundred dispersed after her first flight, but when Earhart sailed into the sky a second time that day she remained airborne for about three hours and set a woman's Autogiro altitude record of 18,415-feet.**

**Above L&R: caption: "Amelia Earhart with her Autogiro after setting altitude record"**

**\$12,000,000 IN LOANS**

papers to Show Dummy  
ns Were Formed a Few  
Before Deal Involved.

**IS FIRST WITNESS**

indicates That Defense Will  
d That Transaction  
Was Not Illegal.

secution in the trial of  
. Marcus, president of the  
nited States, and three as-  
a charge of felony aris-  
an alleged misapplication  
of a subsidiary of the  
ed its case before Judge  
Donnellan in the Court of  
isions yesterday.  
teuer, special prosecutor,  
the jury, outlined the  
ing up to the failure of

however, was dropped.

**MISS EARHART SETS  
AUTOGIRO RECORD**

Altitude of 19,000 Feet, Highest  
Ever Made in a 'Windmill,' Is  
Registered in Pennsylvania.

**ENCOUNTERS NO TROUBLE**

Aviatrix Reaches 'Ceiling' on  
Second of Two Flights in Day—  
Barograph to Be Checked.

*Special to The New York Times.*  
PHILADELPHIA, April 8.—Miss

Seabury in  
Hofstadte  
on Own

**PLEDGES UNBI**

Urges That the L  
Additional Fund  
"Gigantic

**PLANS TO WOR**

Will Study Stru  
for City Govern  
Works on H



**Harold Pitcairn and Earhart's husband; George Palmer Putnam, had seen to it that the world altitude flight was well-covered by the news media which was always eager to cover the achievements of the photogenic lady flyer. Such acclaim met each party's needs and they sought to capitalize further with the first transcontinental flight. Seeing a publicity bonanza, the *Beech-Nut Packing Company* offered Earhart the use of its previously ordered *Pitcairn PCA-2* if she would fly it coast-to-coast with the company logo painted on its side and accompanying promotional efforts related to its chewing gum. Brokered by her husband (who was known for his acumen at garnering publicity), she promptly canceled her order in favor of the Beech-Nut Autogiro. However, since Beech-Nut was scheduled to receive the 13th production model, Earhart, superstitious about such things, requested that she receive a lower number and in fact received the twelfth production model.**

**Left: caption: "Amelia Earhart and George Putnam"**





**Putnam canceled his own Autogiro order with Pitcairn after he arranged to have his wife fly Beech-Nut's Autogiro on the trans-continental tour. He was on hand to pass out chewing gum when she took off in the company's vivid green Autogyro from *Newark, N.J.*, on May 29<sup>th</sup> 1931, accompanied by mechanic *Eddie de Vaught*.**



**Amelia Earhart** had undergone a tonsillectomy just a month before departing on her “Beech-Nut Transcontinental Autogiro Tour,” but she tackled the strenuous tour admirably. The ungainly looking aircraft, with its stubby wings, 300-hp *Wright Whirlwind* engine and 45-foot-diameter rotor blades, drew plenty of curious spectators as did its famous pilot. Since the Autogiro had to be refueled frequently, Earhart made many stops in small communities across the country. The weather also affected her schedule, such as when she had to land at tiny *Sidney, Nebraska* because of strong headwinds. Often she attended luncheons and banquets in her honor dressed in her flying clothes; leather jacket, jodhpurs and boots. She explained to one writer that she had no room in the open cockpit to carry a change of clothes.

**Left:** caption: “Rock Springs, WY - June 4, 1931. Amelia Earhart with her <sup>145</sup> Autogiro during Beech-Nut Tour”



After much preparation and orchestrated publicity, Earhart left *Newark, NJ* on May 29<sup>th</sup> 1931 and headed west. Accompanied by mechanic *Eddie Vaught* and making as many as ten landings per day, she proceeded along the northern mail route to *Oakland, California*. At each stop she lifted children up to see the cockpit, shook hands with spectators, gave interviews and often gave out samples of *Beech-Nut* chewing gum. Arriving on June 6<sup>th</sup> 1931 in Oakland, she discovered much to her amazement and her husband's anger that *Marine Corps Reserve Lt. John M. Miller* had arrived in *San Diego* on May 28<sup>th</sup> 1931 (in the thirteenth production PCA-2) having left *Willow Grove, PA* on May 14<sup>th</sup> 1931 with no fanfare. Thus, *Amelia Earhart* was deprived of the transcontinental record for an Autogiro. Earhart flew an average of five hours a day at about 80 mph in her Autogiro. In *Wyoming* she landed at *Cheyenne, Laramie, Parco, Rock Springs* and *Leroy*; towns roughly one-hundred miles apart. The *Wyoming State Tribune* estimated she drew half the state capital's population to see the strange flying machine when she arrived on June 4<sup>th</sup> 1931. The *Rock Springs* newspaper claimed that two-thousand people were on hand to watch as the Autogiro "dropped almost vertically from the heavens" and made a "safe and somewhat esthetic landing." Earhart explained to one Wyoming reporter that she wanted the public to realize the Autogiro was "not a circus contraption...a practical and scientific and safe means of air navigation." Not everyone in the aviation industry agreed with her. Many pilots expressed concern about the safety of the experimental aircraft resulting in the sinister nickname "Black Maria." On the contrary, Earhart told interviewers the Autogiro was "the answer to an aviator's dream." 146



In a reception typical of her stopovers during the tour, Earhart was greeted at Denver's airport by a host of local luminaries, including *Frederick Bonfils*, publisher of the *Denver Post*. People crammed rooftops to watch her demonstration flight there (which was vividly recounted in the *Post's* front-page story). She sped about 100-feet down the runway as the propeller spun and the rotor blades whipped the air above her. When she pulled back on the stick, "the ship jumped from the ground like a scared rabbit," then began climbing at a 75-degree angle. After reaching an altitude of 1K-feet, she returned to the airport, making a sound landing with "no jolt at all."

Left: caption: "Amelia Earhart at the Reading Airport, her first stop on the cross-country flight in the Beech-Nut Autogiro"

Right: caption: "Amelia Earhart flying over Pennsylvania in Beech-Nut Autogiro during Transcontinental Tour"



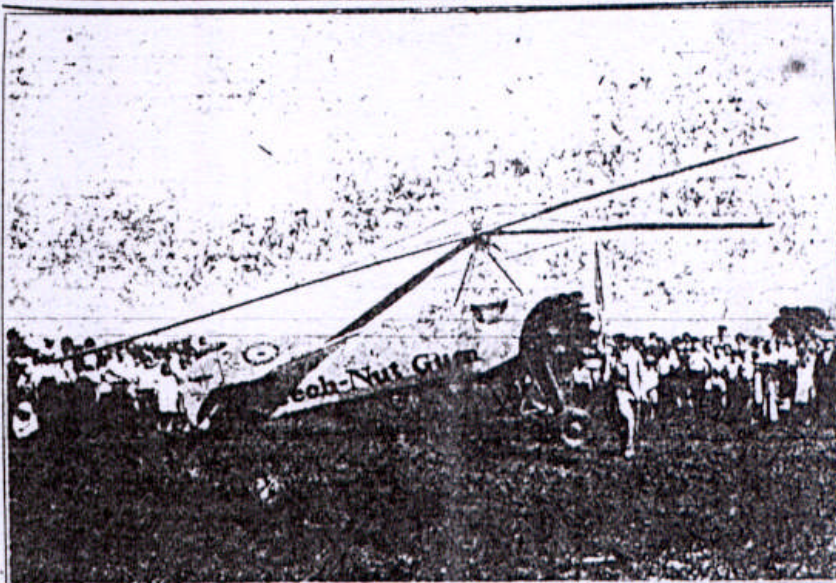

Weather Permitting  
**AMELIA EARHART**  
WILL FLY

**Beech-Nut Autogiro No. 1**

At Curtiss Airport

Raleigh, N. C.

SATURDAY, NOVEMBER 7th  
10:30 A. M. and 2:30 P. M.

Positively the only flights Miss Earhart will make during her stay in Raleigh! Don't Miss It!

This is the famous Beech-Nut Autogiro in which Miss Earhart recently completed the first round trip transcontinental flight ever made in this type of airplane.

Saturday's flights mark the first demonstration of an Autogiro in Raleigh. The public is cordially invited to visit the airport, inspect the Autogiro and witness Miss Earhart's flight. The take-off and landing are a revelation to those unfamiliar with remarkable new development in airplanes.

This will be an unusual opportunity for residents of Raleigh and vicinity to see a most interesting new aircraft—flown by one of aviation's most famous pilots. Miss Earhart not only has the distinction of being the first woman to fly across the Atlantic, but holds the altitude record for Autogiros—18,400 feet.

The Time: 10:30 A. M. and 2:30 P. M. Saturday  
The Place: Curtiss Airport, Raleigh, N. C.

**There Is No Admission Charge**

*“Arriving in an autogiro, the first aircraft of the sort to be seen in Raleigh, Miss Earhart literally dropped down on the field. Other planes may hover and swoop and glide over the field, but the autogiro with a whirl of its propeller, made a vertical descent and came to rest close by the airport hangar, a strange looking air visitor...It would be hard to say which was the bigger attraction, Miss Earhart or the autogiro, and during the three days that they are in Raleigh the city will have opportunity to see both a number of times...Miss Earhart will give a demonstration flight at the Curtiss-Wright Airport. The general public is invited to attend this demonstration. Saturday evening Miss Earhart will deliver a fifteen-minute talk over Radio Station WPTF. At the Saturday demonstration, Miss Earhart will show all the remarkable possibilities of this newest type of aircraft. The flying features of the autogyro are most spectacular. It makes short take-offs, steep climbs, stands still in the air, flies backwards and makes vertical descents with little or no runs. Many aviation authorities consider that the new type plane will be safe, practical and popular aircraft of the future.”*  
*The News & Observer, November 7<sup>th</sup> 1931*      149



Upon her arrival in *Oakland, CA* on June 6<sup>th</sup> 1931, throngs of onlookers stormed through barriers to greet *Lady Lindy*. Earhart had hoped to set a record as the first pilot to cross the country in an autogyro, but she was disappointed to learn that *Johnny Miller* (left) (the first person to purchase a *Pitcairn PCA-2 Autogyro*) had done just that only two weeks earlier (in May 1931).

Above: caption: "Glendale, CA - June 7, 1931 Amelia Earhart receives warm welcome at Grand Central 150 Air Terminal in Los Angeles"



**Beech-Nut's Autogiro had performed flawlessly thus far, seemingly validating Earhart's confident appraisal of the aircraft. But during her return trip she encountered some difficulties that called her ability as a pilot into question. On June 12<sup>th</sup> 1931, she was preparing to land in *Abilene, Texas*, in front of a crowd when the winds suddenly calmed. She aimed the craft away from the onlookers, narrowly missing them as she crash-landed. Earhart climbed out of the cockpit unhurt, but the Autogiro had been badly damaged. Arrangements were made for another Autogiro to be flown from *Pitcairn Field in Willow Grove, PA* to *Oklahoma* so the tour could continue. According to news reports, she flew from Abilene to *Oklahoma City* in a plane piloted by another flier.**

**Left: caption: "Abilene, TX - June 11. Beech-Nut Autogiro nose-down after Amelia Earhart's crash on take off."**

**Right: caption: "Abilene, TX - June 11. Beech-Nut Autogiro surrounded by onlookers 151 after Amelia Earhart's crash on take-off."**





***“The air just went out from in under me. Spectators say a whirlwind hit me. I made for the only open space available...With any other type of plane the accident would have been more serious.”***

***Amelia Earhart***

**RE: the *PCA-2* had dropped thirty-feet, hit two cars and damaged its rotor and propeller. She and the accompanying mechanic were unhurt, but her attempt at setting a record (using the southern mail-route) on the eastbound cross-country return trip (to avenge rival John Miller’s preempting her for the first (westbound) trans-continental Autogiro record by just nine days) was ended. She returned to the East Coast by train. The Aeronautic Branch of the *Department of Commerce* (renamed the *Bureau of Air Commerce* in 1934) did not accept her version of the incident and issued her a formal reprimand for “carelessness and poor judgment” based on the report made by the local inspector *R.W. Delaney*. Actually, the government had intended to ground Earhart for ninety days had her friend *Senator Hiram Bingham* not interceded. He secured a lesser penalty; a formal reprimand from *Clarence Young*, then *Assistant Secretary of Commerce for Aviation*.**

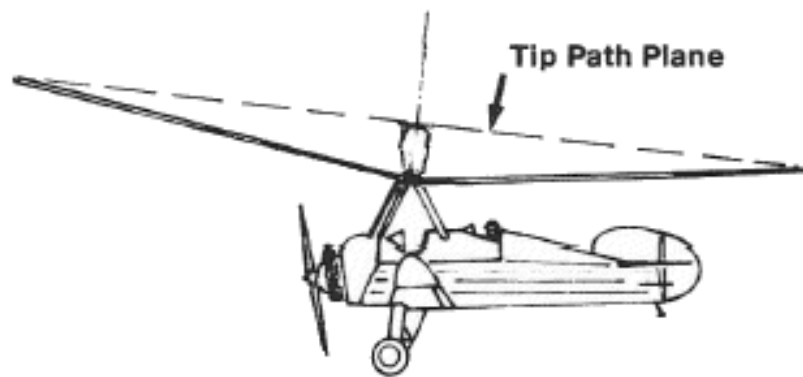

Fig. 9

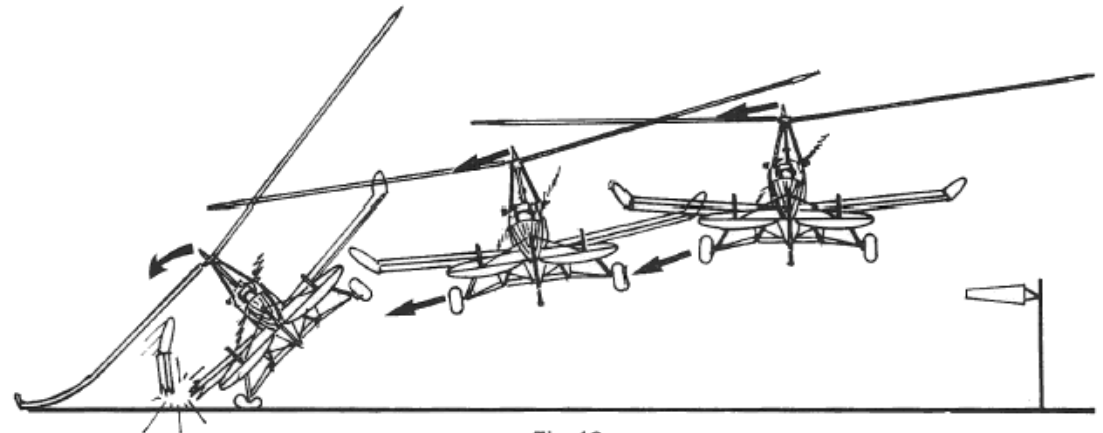

Fig. 10

In forward flight, the blades of an Autogiro are flapped up in the front and flapped down in the rear. The blades climb up from their low position at the tail to the high position at the nose and descend back to the tail position. An imaginary line drawn from the tip of the most-forward blade to the tip of the rear-most blade would describe the blade tip position at any point in its rotation. This is called the “tip path plane” (fig. 9, at left). Furthermore, air passes up through the rotor disc (unlike the downwash from a helicopter rotor). Although the rotor could not stall, even when the autogiro is flying at very low airspeed or even zero airspeed, the airplane-type control surfaces that were used on early autogiros could stall. When brought in for a landing, and the nose pulled up to reduce the contact speed, all control was lost. If the autogiro was too high when the flare was performed and the nose was not directly into the wind, the Autogiro might begin to drift away from the wind. If this did happen and the autogiro contacted the ground in this altitude, the down-wind wheel would strike the ground sideways and the lift from the rotor, high above the wheel would cause the craft to roll over (fig. 10, at right). This was seen as a serious problem and the early pilots, who were professionals for the most part, learned to avoid this condition. As more Autogiros were manufactured and amateur pilots (who did not have had the same piloting experience) bought them, an increase of these crosswind accidents occurred.



When Earhart stopped in *Tulsa, OK*, she was dismayed to learn that the *Department of Commerce* had issued her a formal reprimand. Senator *Bingham's* (president of the *National Aeronautic Association* of which Earhart was vice president) intervention on her behalf prevented her from being grounded. Stung by the criticism, she vented her frustration in an article in the *New York World-Telegram*, contending that the accident examiner who had interviewed her after the crash had never flown an Auto-giro nor even seen one in flight. She also complained that rather than receiving an official notice of reprimand, she had first learned of the embarrassing judgment through the press.

Left: caption: "Ameilia Earhart<sup>155</sup> on her Autogiro during Tour"





## AUTOGIRO FLIGHT INSTRUCTION

### *A Comprehensive Course by Specialist Instructors*

The Autogiro flying school offers complete facilities for those wishing to take a practical course of instruction under the most ideal conditions.

The latest equipment, combined with individual attention by enthusiastic and experienced instructors, ensures your rapid progress.

The Autogiro is the ideal aircraft for all-initio pupils wishing to take a pilot's licence with maximum safety and comfort at minimum cost.

A complete "A" licence course, all dual instruction and solo flying for Air Ministry requirements for . . . . .

# £35

INCLUSIVE

***"...a novice is placed in much the same position as when learning to drive a motor car. Mistakes are not necessarily dangerous, if he becomes confused, he can stop and let the ship land itself..."***

***Aero Digest, December 1930***

**RE: 1930s-era advertisements (example at left) for the Autogiro called attention to its power and potential, highlighting its safety and ease of flight training which promised a revolution in aviation.**

**IMPORTANT NOTICE**  
to those about to take up  
**FLYING INSTRUCTION**

THE AUTOGIRO is the SAFEST and MOST PRACTICAL Aircraft for Flying Tuition. It cannot stall or spin. It ensures complete control throughout its very wide speed range. It has a rapid take-off and steep climbing angle, and it can be landed without forward run.

Complete Ab Initio "A" Licence Course, all dual instruction and solo flying for Air Ministry requirements . . . . . **£35**  
(including)

We have successfully trained Pupils ranging in age from 17 to 69!

**SPECIAL CHARTER**  
Latest types of Autogiros available for cross-country flights at competitive rates.

*Write for particulars now.*

LONDON AIR PARK HANWORTH

TELEPHONE FELTHAM 2621

**THE CIERVA**  
**AUTOGIRO** CO LTD  
BUSH HOUSE ALDWYCH LONDON WC2 (TELEPHONE TEMPLE BAR 2561)

## Important Notice

### to Those About To Take Up Flying Instruction

The Autogiro is the safest and most practical aircraft for flying tuition. It cannot stall or spin. It ensures complete control throughout its very wide speed range. It has a rapid take-off and steep climbing angle, and it can be landed without forward run...Complete Ab Initio "A" License Course. All dual Instruction and Solo Flying for Air Ministry requirements. £35-00 We have successfully trained Pupils ranging in age from 17 to 69

### Special Charter

Latest types of Autogiros available for cross country flights at competitive rates



FOR ALL WHO FLY OR WANT TO LEARN

**T**HIS Pitcairn Autogiro is a sister ship to those whose countless miles of flight from coast to coast have shown a new source of security to those who fly or want to learn to fly. Here you can see the rotor, whose blades are turned constantly by natural forces alone, to supply continuous support independent of the engine or maneuvers of the pilot. It is this support and the security it provides which make the Pitcairn Autogiro the craft so obviously suited for the needs of the amateur or private owner flyer. Write for a copy of the book, "It Lands in the Length of Its Shadow." It describes the 300 h. p. three-place and 125 h. p. two-place Pitcairn Autogiros available, and tells more about their principle of flight. Pitcairn Aircraft, Inc., Pitcairn Field, Willow Grove, Pa.

**PITCAIRN**  
*autogiro*

PITCAIRN AIRCRAFT, INC., PITCAIRN FIELD, WILLOW GROVE, PA.

**Left: caption: "This Pitcairn Autogiro is a sister ship to those whose countless miles of flight from coast to coast have shown a new source of security to those who fly or want to learn to fly. Here you can see the rotor, whose blades are turned constantly by natural forces alone, to supply continuous support independent of the engine or maneuvers of the pilot. It is this support and the security it provides which make the Pitcairn Autogiro the craft so obviously suited for the needs of the amateur or private owner flyer. Write for a copy of the book, 'It lands in the length of Its Shadow.' It describes the 300 h.p. three-place and 125 h.p. two-place Pitcairn Autogiros available, and tells more about their principle of flight..."**





**Prospective Pupil:**  
"Is it easier to learn on an Autogiro than on a fixed wing type?"

**Pilot Instructor:**  
"Yes, because the Autogiro in the air practically flies itself, requires no tricky judgment of the approach to land and also can be put down without many hours of learning the art of 'holding-off' in order to make a successful landing."

**Prospective Pupil:**  
"I hear it is safer also..."

**Pilot Instructor:**  
"That is very true, the Autogiro cannot stall or spin however faultily it is flown—loss of air speed need not worry the novice."

**Prospective Pupil:**  
"Will it take long to learn by Autogiro?"

**Pilot Instructor:**  
"No, we can teach you quickly, and remember, also, when you go solo our sound instruction combined with Autogiro characteristics will give you absolute confidence."

**Prospective Pupil:**  
"Well, book me for one of your £1 Is. Trial Lessons now!"

A complete "A" licence course. All dual instruction and solo flying for Air Ministry requirements. **£35** No Extras

If you hold an "A" licence we offer you dual instruction and one hour's solo flying for **£5** inclusive

Full particulars from —

**THE CIERVA**  
**AUTOGIRO**

BUSH HOUSE, ALDWYCH, LONDON. W.C.2

(Tel.: Temp. 849 356)

AERODROME: LONDON AIR PARK, HANWORTH, MIDDLESEX. Tel.: Feltham 236

**Prospective Pupil:**

"Is it easier to learn on an Autogiro than on a fixed wing type?"

**Pilot Instructor:**

"Yes, because the Autogiro in the air practically flies itself, requires no tricky judgment of the approach to land and also can be put down without many hours of learning the art of 'holding-off' in order to make a successful landing."

**Prospective Pupil:**

"I hear it is safer also..."

**Pilot Instructor:**

"That is very true, the Autogiro cannot stall or spin however faultily it is flown—loss of air speed need not worry the novice."

**Prospective Pupil:**

"Will it take long to learn by Autogiro?"

**Pilot Instructor:**

"No, we can teach you quickly, and remember, also, when you go solo our sound instruction combined with Autogiro characteristics will give you absolute confidence."

**Prospective Pupil:**

"Well, book me for one of your £1 Is. Trial Lessons now!"

**INDISPUTABLY**  
**THE *safest***  
**AIRCRAFT OF TO-DAY**



- **BECAUSE** it cannot stall or spin.
- **BECAUSE** it maintains height and is under full control at 20 m.p.h. (Vital in conditions of bad visibility.)
- **BECAUSE** it can descend vertically and land without forward run. (No fear of hitting ground obstructions at high speed.)
- **BECAUSE** it has a steep angle of climb. (It can be operated in the smallest area.)
- ★ **BECAUSE** of its unrivalled safety characteristics it is the finest aircraft for  
**FLYING INSTRUCTION**  
 Full ab-initio course of tuition available for "A" licence, by Autogiro experts at £35 inclusive.  
*Particulars sent on request.*

**AVOID ACCIDENTS**  
 . . . . **FLY BY AUTOGIRO**

THE CIERVA  
**AUTOGIRO**  
BUSH HOUSE, ALDWYCH, LONDON, W. C. 2

**INDISPUTABLY**  
**THE *safest* AIRCRAFT OF TO-DAY**

- **BECAUSE** it cannot stall or spin
- **BECAUSE** it maintains height and is under full control at 20 m.p.h. (vital in conditions of bad visibility)
- **BECAUSE** it can descend vertically and land without forward run. (No fear of hitting ground obstructions at high speed)
- **BECAUSE** it has a steep angle of climb. (It can be operated in the smallest area)
- **BECAUSE** of its unrivalled safety characteristics it is the finest aircraft for

**FLYING INSTRUCTION**

**Full ab-initio course of tuition available for "A" License by Autogiro experts at £35 inclusive. Particulars sent on request.**

**AVOID ACCIDENTS...FLY BY AUTOGIRO  
 THE AIRCRAFT FOR PRACTICAL AIR TRAVEL.**



**IS it SAFER to  
FLY at 80 or 20 mph.  
when visibility is BAD?**

Obviously the answer is 20 m.p.h.—if your aircraft is capable of a SAFE slow air-speed!

No sane motorist would drive at 50 m.p.h. in a fog—yet the Aeroplane pilot has no option and must fly at high speed even if visibility is practically nil.

The Autogiro pilot is indeed lucky in bad weather conditions, he can cruise along comfortably at 20 m.p.h. feeling his way through the mirk in safety—secure in the knowledge that his craft cannot possibly stall and suddenly “drop out of his hands.”

Speed, comfort and safety are assured with the Autogiro—

**THE AIRCRAFT  
FOR PRACTICAL AIR TRAVEL**

Tripplou - Totals for 261

**THE CIERVA  
AUTOGIRO**  
BUSH HOUSE, ALDWYCH, LONDON, W. C. 2

## **IS it SAFER to FLY at 80 or 20 mph when visibility is BAD?**

Obviously the answer is 20 m.p.h. - if your aircraft is capable of a SAFE slow air-speed! No sane motorist would drive at 50 m.p.h. in a fog - yet the Aeroplane pilot has no option and must fly at high speed even if visibility is practically nil. The Autogiro pilot is indeed lucky in bad weather conditions, he can cruise along comfortably at 20 m.p.h. feeling his way through the mirk in safety - secure in the knowledge that his craft cannot possibly stall and suddenly “drop out of his hands.” Speed, comfort and safety are assured with the Autogiro

**THE AIRCRAFT FOR PRACTICAL AIR TRAVEL.**

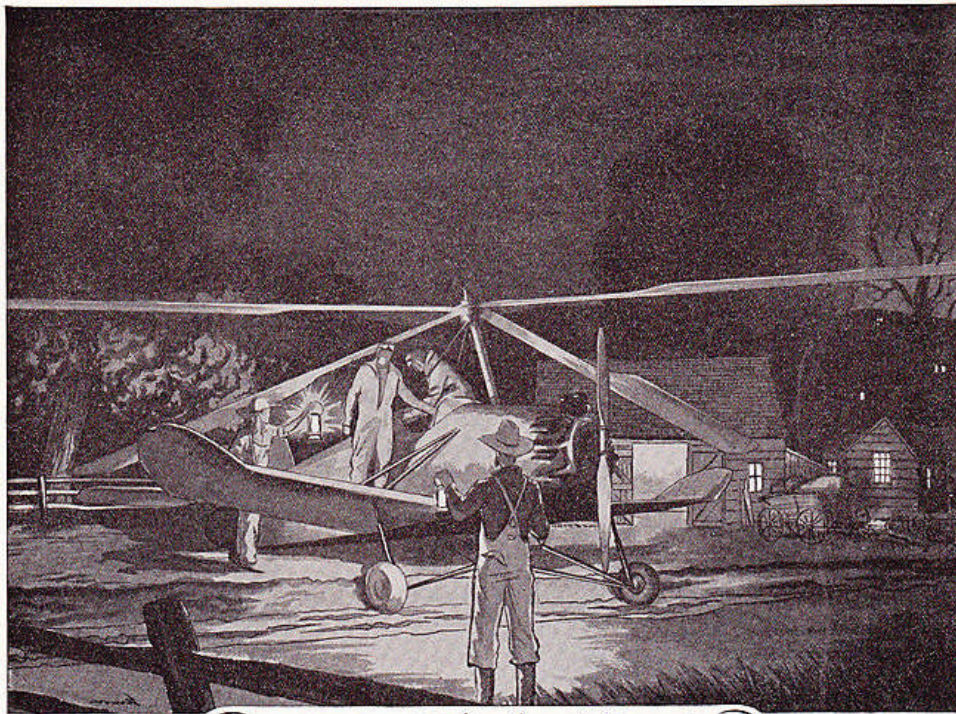

*" . . . . We landed in the  
backyard of a farmhouse . . . "*

"To make a long story short, we finally passed over the Utica Airport and started on the last lap. The lights of Syracuse appeared and I cut north of the city direct for the airport. Suddenly the motor coughed and stopped completely out of gas. Embarrassing, to say the least. The ground below was absolutely black and it was impossible to distinguish whether we were going to land on trees, deserted houses or what have you. There being only one thing to do, I headed into the wind, and came down vertically 2,000 feet. We landed in the backyard of a farmhouse with no more shock than the average landing and without forward roll of an inch. The wheels landed in a one-foot ditch, which with any forward movement of the ship would have turned us over. Actually there was no damage done to the ship whatsoever. Had we been in an airplane without flares and landing lights, making contact with the ground at 50 or 60 miles an hour, the results would have been different, to say the least. Evidently we had run into 40 or 50 mile head winds." LESLIE B. COOPER (Kellett K-2 Autogiro)

Cross country, black-night flying is not common practice for the average Autogiro owner. But even though Mr. Cooper is a veteran airplane pilot he attributes his remarkable landing more to the inherent security of the Autogiro itself, than to his own flying skill.

The Autogiro Company of America is an engineering and licensing organization. It owns

and controls, exclusively, all Autogiro patent rights in the United States. Manufacturing companies of high standing will be licensed to build Autogiros with the full cooperation of our engineering staff. Present licensees are: Buhl Aircraft

Company, Detroit, Mich. . . . Kellett Aircraft Corp., Philadelphia, Pa. . . . Pitcairn Aircraft, Inc., Willow Grove, Pa.

**AUTOGIRO**

**Left: caption: "To make a long story short, we finally passed over the Utica Airport and started on the last lap. The lights of Syracuse appeared and I cut north of the city direct for the airport. Suddenly the motor coughed and stopped completely out of gas. Embarrassing, to say the least. The ground below was absolutely black and it was impossible to distinguish whether we were going to land on trees, deserted houses or what have you. There being only one thing to do, I headed into the wind, and came down vertically 2,000 feet. We landed in the backyard of a farmhouse with no more shock than the average landing and without forward roll of an inch. The wheels landed in a one-foot ditch. Which with any forward movement of the ship would have turned us over. Actually there was no damage done to the ship whatsoever. Had we been in an airplane without flares and landing lights, making contact with the ground at 50 or 60 miles an hour, the results would have been different, to say the least. Evidently we had run into 40 or 50 mile head winds. Leslie B. Cooper (Kellett K-2 Autogiro)"**

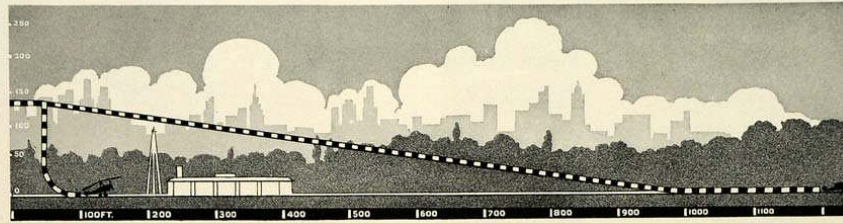

COMPARATIVE AREA REQUIRED FOR SAFE LANDING OF AUTOGIRO AND AIRPLANE—COMPARATIVE DATA 300 H. P. PITCAIRN AUTOGIRO—300 H. P. PITCAIRN MAILWING

IT KNOWS HOW TO  
GET DOWN

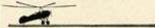

Come down when and as you will. Glide down to touch the earth as gently as a bird. If you prefer, come down straight—for here is a type of aircraft with a way of landing all its own.

With the engine dead or idling, it will bring you down, slower than a man in a parachute, to let you land on any selected spot with no forward run required.

Ease of landing is matched by ease in flying safely, either high or low. Even if you never flew before you can learn to fly a Pitcairn Autogiro in a few hours, under personal instruction included in the purchase price of your ship.

You climb, you bank and turn, come down and land, without regard for flying speed or fine exactness in flying judgment. For here is a craft that can not fall into a tail spin, since the blades which are the lifting surface can not stall. It is sustained by four rotating blades, independent of the engine or your skill. They are rotated by natural forces and provide sustaining power as long as the craft is in the air.

Because it brings you down in comfort and security, lands and takes off in restricted areas, it is obviously the craft for the private owner-flyer. Whether on sport or business you may start a day's flight from almost any country estate. Land on any polo field, golf course, or other available area near your destination. Come back home at night, not to a distant airport, but to your starting point.

The Pitcairn Autogiro offers to amateur and professional alike, flight that may be fast or slow, high or low, and above all with security comparable with that of your own motor car. In production now are a 300 horse power, three-place model, and a 125 horse power, two-place, tandem cockpit sport model. Write for the new book, "It Lands in the Length of Its Own Shadow."



*Advantages—Steep angle of climb, short radius of turn . . . Can not go into a tail spin . . . Lands vertically without any ground roll . . . Descends in a glide with short ground roll . . . Descends slower than a man in a parachute . . . Takes off at slow speeds, lands with no forward speed . . . Flies fast, slow, or hovers momentarily . . . Easy to learn to fly, its characteristics make it the aircraft for the private owner-flyer.*

PITCAIRN  
AUTOGIRO

**Left: caption: "Advantages – Steep angle of climb, short radius of turn...Can not go into a tail spin...Lands vertically without any ground roll...Descends in a glide with short ground roll...Descends slower than a man in a parachute...Takes-off at slow speeds, lands with no forward speed...Flies fast, slow, or hovers momentarily...Easy to learn to fly, its characteristics make it the aircraft for the private owner-flyer."**

**RE: excerpt from a 1931 advertisement for the Pitcairn Autogiro**

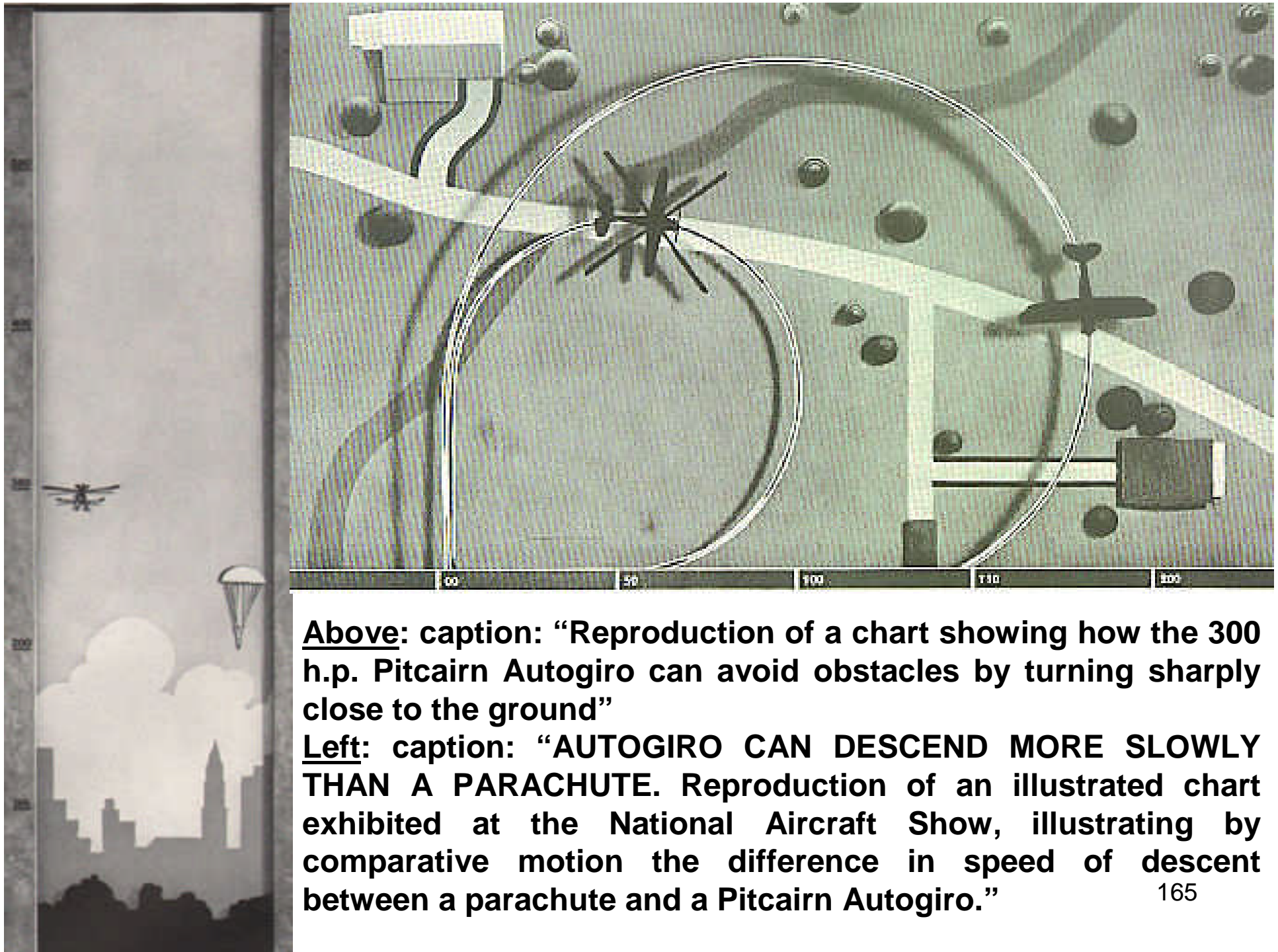

**Above:** caption: “Reproduction of a chart showing how the 300 h.p. Pitcairn Autogiro can avoid obstacles by turning sharply close to the ground”

**Left:** caption: “**AUTOGIRO CAN DESCEND MORE SLOWLY THAN A PARACHUTE.** Reproduction of an illustrated chart exhibited at the National Aircraft Show, illustrating by comparative motion the difference in speed of descent between a parachute and a Pitcairn Autogiro.”

**MILK & ICE FUND  
BENEFIT**

**AIR  
SHOW**



Featuring  
**AMELIA  
EARHART**  
and her

**AUTOGIRO**

at the **FAIR GROUNDS**  
**SUNDAY JUNE 14-2 1930**

**Select Parking Space**

Now on sale by Junior League  
Members at \$1.00 per car; GEN-  
ERAL ADMISSION on day of  
event: cars 30c; grandstand—  
adults 25c, children 15c . . . all  
receipts go to the Milk and Ice  
Fund. . . . Expenses paid by the  
Oklahoma Publishing Company.

**Earhart + 'Giro' + Stunts = Thrilled Throng**

All that's needed is the co-operation of the weather man against the usually possibility of rain and this week that L. F. Thompson, Daily Oklahoman staff artist, has depicted will be duplicated at Fair-grounds Sunday afternoon. One of the largest crowds in Oklahoma City aviation history is expected to jam the park to see Amelia Earhart put her new Autogiro through its paces in a benefit aerial show, all proceeds of which will go to The Daily Oklahoman and Times milk and ice fund.



**WOMAN FLIER  
IS DUE TODAY  
FOR GIRO SHOW**

Earhart's *Texas* mishap did little to diminish the fanfare surrounding her tour. Prior to her Autogiro demo in *Oklahoma City*, for example, the program included a serenade by a 42-piece band, an airshow featuring what one report said was "practically every plane in Oklahoma City," formation flying, a parachute jump and a demonstration by a local woman stunt pilot.



***“My giro spill was a freak accident. The landing gear gave way from a defect and I ground-looped only. The rotors were smashed as usual with giros, but there wasn’t even a jar.”***

***Amelia Earhart***

**RE: excerpt from letter to her mother concerning second crash on 09/12/31. During the course of her cross-country tour, Earhart stopped in seventy-six towns in three weeks of travel. Eager to keep her name and face before the public, Putnam booked her on additional Autogiro tours. Her second tour began in August 1931. On September 12<sup>th</sup> 1931, at the *Michigan State Fair in Detroit*, Earhart once again crash-landed. This time Putnam was in attendance and when he heard the commotion he ran to rescue his wife. In the process, he tripped on a guy wire, spraining his ankle and injuring his ribs. Earhart, who had once again escaped injury, continued the tour while Putnam recuperated in the hospital. In November 1931, Earhart began a whirlwind tour of thirteen southeastern states. During this trip, she sometimes made appearances on behalf of charities. For example, in *Raleigh, NC*, she arrived a day early to help a local organization raise funds to prevent the city from having to start a soup and bread line; a common situation in depression-era *America*. She stayed from two to four days at each of her stopovers during 167 the tour.**





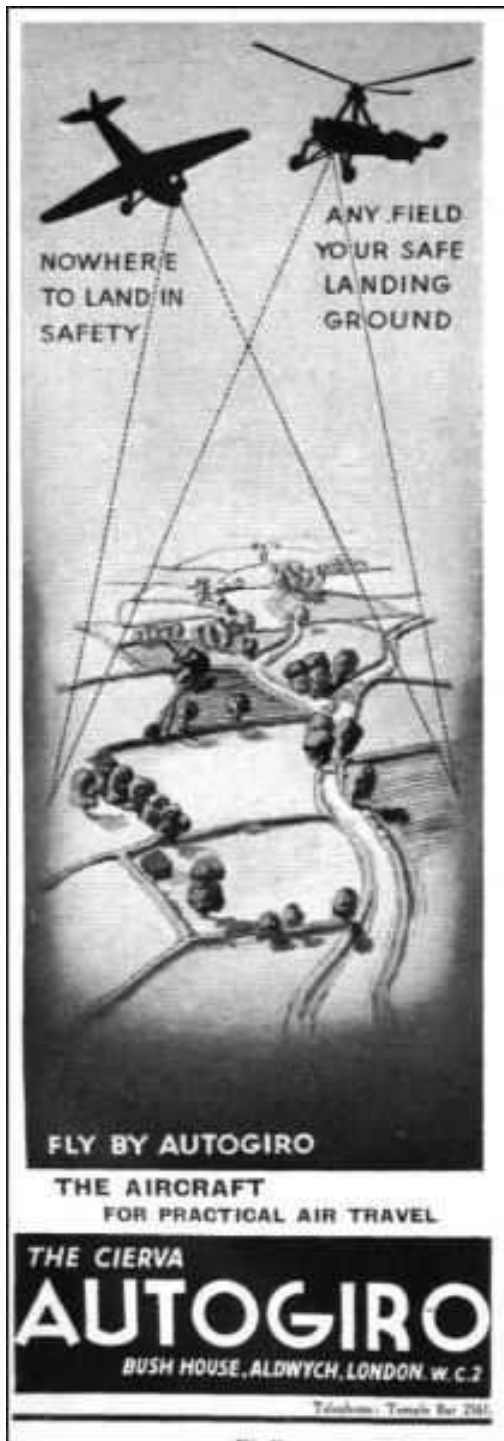

With 20-20 hindsight, it's fair to say that Amelia Earhart's involvement with the Autogiro was relatively insignificant. The general consensus was that she was an "impatient pilot" and that her accidents were the product of a lack of both training and attention to detail. The crash in *Kansas* appears to have resulted from forcing take-off without the rotors having achieved high enough rotation, while *Detroit* was the result of not having spent enough time practicing landings. To be sure, the Autogiro, despite Pitcairn's public claims of ease of operation touted in virtually every advertisement and public pronouncement, was a difficult aircraft. Earhart's friend, pilot *Blanche Noyes*, who was hired to fly a *PCA-2* for an oil company, ridiculed Pitcairn's claim that "a ten-year-old boy" could fly an Autogiro. She related, in her Oral History (which is part of a collection at *Columbia University*) that the factory training aircraft was called the "Black Maria" because so many pilots had accidents. It is also well known that she accepted the Beech-Nut tour/s because she needed the money.



***“...It is reported that Amelia Earhart, since her two crashes, opines that it is as hard to make a perfect landing with an autogiro as it is to make a perfect drive on the golf course...”***

***Fortune magazine, March 1932***

***Left: Amelia Earhart appearing in a 1928 magazine advertisement for Lucky Strike cigarettes (after her successful trans-Atlantic crossing). Although Earhart did additional flying for Beech-Nut in a mutually profitable arrangement, her significant contact with the Autogiro finished with the end of 1931. She was already planning the solo trans-Atlantic flight of May 20-21, 1932, which would win her the National Geographic Society Special Medal - the first awarded to a woman pilot. After the crash in Detroit, she was overheard to say: “I’ll never get in one of those machines again. I couldn’t handle it at all.” While Autogiro accidents were commonplace, they were usually more embarrassing and costly than fatal. Worse yet, the Autogiro was not living up to its promise of safe aviation.***

# EARHART PLANE LOST AT SEA

(Start on Page 8)



**Amelia Earhart Missing on World Flight**

Following a search for Amelia Earhart and Fred Goetz, her navigator, were believed down in the Pacific near South Island, on 2,800-mile leg from San Francisco. Friends thought they would meet her some time. This picture was made at Newark, N.J., on the day they were granted by President Johnson (right) an aerial tour on photographic flight.



Above: this photograph of *Amelia Earhart* was taken just prior to her famous flight that led to her disappearance. She is sitting in the cockpit of her *Lockheed Electra*.

Left: when news of her disappearance hit, it was front page news. There was hope that she would be found however, those hopes would eventually be dashed when neither Earhart, her navigator or the plane were ever found. 171



There have been many theories offered as to what exactly happened to *Amelia Earhart* (left). One theory suggested the flight was an elaborate scheme to spy on the Japanese (at the behest of *President Roosevelt*) whereby she and her navigator were shot down, captured and executed as spies. There are two other explanations that are more likely to be closer to the truth about what happened to Amelia Earhart and navigator *Fred Noonan* (above). The first has them crash landing into the *Pacific*, resulting in their death and the complete destruction of the airplane. The other has them crash landing either on or close to a small Pacific island and surviving for a short time thereafter. The latter theory now has some credible evidence to support it. 172



***“...whereas an airplane of similar size and power might cost \$11,000...and the Pitcairn sport model for \$6,750 – and here is the real difficulty. An airplane to yield the same service might cost only \$1,500...”***

***Fortune magazine, March 1932***

**RE: in 1932, the state-of-the-art *Pitcairn PCA-2* (above) cost \$15K**

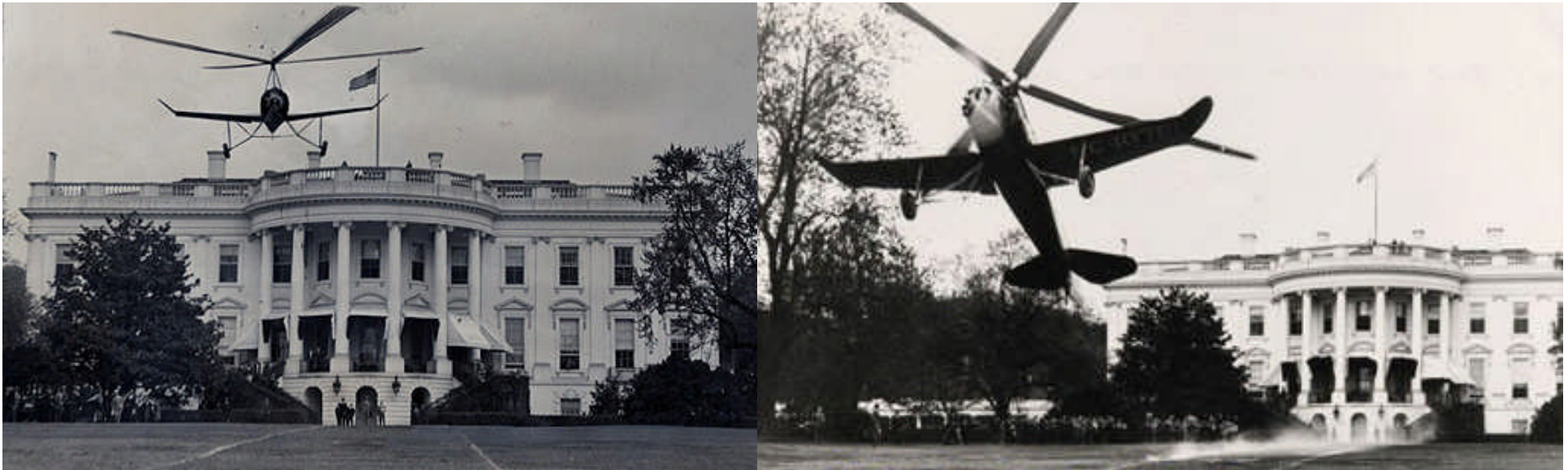

***“...Obviously autogiros are not flying every corner of the sky. Obviously too, consciousness of the autogiro has come up over America’s horizon. The autogiro has hopped on the lawns of the White House, the Capitol, and the Smithsonian Institution, where the first autogiro to fly in this country delivered itself to the very portals within which it is now immortalized. It ha alighted on golf courses, on the piers of ocean liners, and once, when it ran out of gas, it settled at night into the back yard of a farmer. And some sixty-one commercial (as opposed to experimental) have been sold today as compared to one year ago...”***

***Fortune magazine, March 1932***

***Above: Autogiro landing (left) and taking-off (right) on/from White House lawn.***



**The oldest Autogiro in *America* was the *Cierva C.8W* first flown by Cierva test-pilot *Arthur ‘Dizzy’ Rawson* on December 18<sup>th</sup> 1928. When the evaluation of the C.8W was complete, Pitcairn presented it to the *National Air and Space Museum* of the *Smithsonian Institution* on July 17<sup>th</sup> 1931. *Dr. Charles Greeley Abott* – Secretary of the Smithsonian, accepted it after Pitcairn test-pilot *Jim Ray* landed it on the *National Mall* on July 22<sup>nd</sup> 1931. The C8.W was on display for several years, but was transferred to the SI storage facility in *Silver Hill, MD* when it began to deteriorate. 175**



***“...turned out to be a lemon...for all practical purposes...still the only flying machine that could rise from a narrow lawn, loaf through the air as slowly as twenty-five miles an hour, and, if its engine died, settle to earth as gently as a parachute...the trouble was...it would do those things generally only in the hands of experts; and it would not do even for the experts certain other desirable things, like flying fast and carrying a descent load (‘Half the speed and twice the horsepower’ was the contemptuous jibe of airplane pilots and engineers)...”***

***Fortune magazine, March 1936***

**RE: though Fortune magazine had an expressly different view of the Autogiro phenomenon five years after its March 1931 article (which sang its praises) it did, however, consider the introduction of “direct control,” the “jump take-off” and “roadability” (automobile/Autogiro hybrid) to portend a “rebirth” of the Autogiro, replacing the flawed/limited Autogiros that preceded.**



**Left: Cierva Autogiro taking-off from Madrid's *Gran Via* in 1935. It hit overhead tram wires, then crashed and burned (above).**

FOR SAFE FLYING IN 1936.....



CIERVA

**AUTOGIRO**

CO LTD

BUSH HOUSE, ALDWYCH, LONDON W.C.2.

TELEPHONE: TEMPLE BAR 2561



**Top:** caption: “Pitcairn YG-2 (PA-33) Autogiro: Not all the firsts that occurred at Langley were planned, such as the first successful bail-out from a rotary-winged aircraft. On March 30, 1936, pilot William McAvoy and engineer John Wheatley abandoned their Pitcairn YG-2 Autogiro when the rotor failed. The Autogiro ‘NACA 88’ crashed and burned in the Back River, but both men parachuted to safety.”



**Bottom:** caption: “Kellett YG-1B Autogiro: This Kellett YG-1B Autogiro shows one of the problems with these early rotorcraft, cracked rotor blades. This YG-1B was tested by the NACA in late 1939.”



*Wreck Ends Mimic Battle*



**Left: pilots *Al Wilson* and *Johnny Miller* worked together as air show pilots. They staged mock dogfights between Miller's Autogiro and Wilson's modified *Curtiss Pusher*. At the finish of their show during the 1932 *Cleveland Air Races*, Miller landed at the circle in front of the viewing stand and, as the Autogiro's blades continued to turn, Wilson "buzzed" him. The Curtiss Pusher entered the downdraft of the Autogiro blades, struck them, nosed to the ground and crashed. Wilson died two days later.**

# The Towering Take-Off

***“...One of the recent developments of the autogiro is the maneuver variously described as the ‘jump take-off,’ ‘direct take-off,’ and ‘jump-off.’ This maneuver, hereafter referred to as the ‘jump take-off,’ is a take-off with a flight path initially vertical, effected by the release of excess kinetic energy stored in the rotor. The energy is stored by driving the rotor at a speed greater than its normal speed in flight, and during this process the pitch of the rotor blades is reduced to zero. The driving mechanism is disconnected when the desired speed has been attained, the rotor pitch is suddenly increased to either its normal value or a higher one, and this consequent thrust, which is greater than the weight of the machine, lifts it vertically from the ground. During the jump, the rotor decelerates, and the propeller must be operated at full throttle so that the forward speed of the machine will be at least equal to its minimum speed in level flight by the time that the rotor speed drops to its normal value. At this same time, if a rotor pitch greater than normal has been employed for the jump, this high pitch must be reduced to normal. The machine now continues flight from the top of the jump as if a conventional take-off had just been completed...”***

***RE: excerpt from Technical Notes – National Advisory Committee for Aeronautics – Analysis and Model Tests of Autogiro Jump Take-Off (October 1936)***



Up to this point in its development, the Autogiro could cruise at about 100 to 110 mph when fixed-wing craft (with the same horsepower) were cruising at 120 mph. They could fly very slowly (as slow as 20 mph) and could land vertically with adequate control. It was still necessary, however, to make a short run of 20 to 50-feet to become airborne. It would have seemed logical to continue driving the rotor with the engine and take off vertically. One of the main reasons this could not be done was that while the rotor was being driven, a torque was being imparted to the fuselage thus rotating the fuselage (with the weight of the Autogiro on its wheels, the brakes could be used to prevent the rotor torque). If the Autogiro rose into the air without some kind of anti-torque device that would be effective in flight, the fuselage would rotate in the opposite direction of the rotor. The second reason is that the incidence angle, or blade pitch, remained at about four degrees for all the Autogiro's flight modes. This angle was not great enough for an efficient vertical flight even if the torque problem could be solved. A solution was at hand called "jump take-off." The Autogiro could lift itself into the air without power in the rotor and could temporarily have an increase in the rotor blade pitch which would be reduced once in the air.

***“The jump type of start involves an inefficient conversion of energy due to high induced airflow velocities, and is generally, particularly if there is no wind, followed by a substantial loss of height to regain speed after reaching the top of the leap. The purpose of the towering take-off is primarily to hold the machine after the start in the proximity of the ground, thereby keeping the induced drag down, while the air-screw accelerates it to climbing speed, and to regulate the rate of conversion of energy in the rotor through the sensitive feel of this control, in order to suit varying wind conditions.”***

**RE: excerpt from speech made at the *Rotating Wing Aircraft Meeting* held on October 38-29, 1938 at the *Franklin Institute* in *Philadelphia, PA***



***“...The jump take-off promises two important advantages: first, take-off becomes independent of the type of ground available insofar as mud, roughness, or high grass is concerned; and second, the machine is enabled to clear much higher obstacles in a given distance and thus can operate from more restricted fields...”***

***RE: excerpt from Technical Notes – National Advisory Committee for Aeronautics – Analysis and Model Tests of Autogiro Jump Take-Off (October 1936)***



Referred to as a “jump takeoff,” (above) the Autogiro could lift itself into the air without power in the rotor and could temporarily have an increase in the rotor blade which would be reduced once in the air. The system was relatively simple. The blades were all set by the pilot at zero pitch or “no lift position” while the engine turned the rotor at about 150% of normal rpm. The rotor drive was quickly disconnected from the engine and simultaneously the rotor blade angle was increased to about nine-degrees. With the energy that was put into the rotor by over-speeding it, it continued to turn at a higher speed than normal with the blade angle at nine-degrees and the Autogiro rose straight up from five to twenty-feet, depending on the atmospheric conditions. As the rotor rpm slowed, the blade angle automatically returned to its normal four-degree autorotative angle. Several jump take-off Autogiros were delivered to the military, but by this time the helicopter – capable of both vertical take-off and landing, hovering and slow flight, was a practical everyday flying machine.

# Direct Control

## Direct Control American Wingless Autogiros

● Differing radically from previous conventional autogiros, two new models, one an open cockpit type, the other a cabin job, have just been demonstrated to the aviation industry in the United States by Kellett Autogiro Corp., and Autogiro Company of America, respectively. In these models, wings, ailerons and elevators have been entirely eliminated and use of the rudder is optional with the pilot. Three-bladed, folding rotor systems have replaced the rigid, four-bladed units previously used.

Control is maintained through inclination of the entire rotor system, which is so mounted as to pivot on a universal axis in accordance with the conventional movements of the control stick. This new control system provides positive control of the craft at all times and under all conditions ranging from vertical descent and no forward speed to the maximum speed condition.

### Pitcairn Autogiro

Direct control—a return to fundamentals in more ways than one as regards autogiro practice—made its initial appearance in this country when James G. Ray, vice-president of the Autogiro Company of America, demonstrated the first American machine of the type to the public at Washington on November 8.

Direct control means that the entire machine is controlled directly through its sustaining mechanism, or rotor, without the aid of ailerons, elevators, rudder or other surfaces subject to extreme changes in effectiveness with each change in forward speed. In the first American model a rudimentary rudder is used but will be dispensed with on instruction machines. The conventional rudder has proven unnecessary for ordinary flight within the entire speed range.

This speed range is now from 17 to 105 m.p.h. with the experimental machine which has been under development by the Autogiro Company of America since

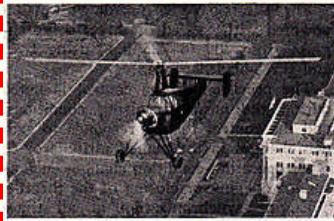

Pitcairn autogiro in flight over Washington

April, 1933, giving a factual ratio of better than 6:1. Performance measurements have been made on days as nearly windless as possible, and corrected by averaging the results of flights both with and against the wind. As evidence of the low speed performance, a man can outrun the machine under ordinary conditions.

While bearing evidence of its experimental nature and history (the machine is in fact a mockup and has been several times altered in nearly all essentials), the performance of the experimental direct control 'giro shows more markedly different characteristics as compared with the other 'giros than was the case as between the first production autogiros and airplanes. Having eliminated the rudder, the factor of coordination between stick movement and rudder bar has disappeared from instruction, and "crossing controls" is eliminated. The control-differential between high and low speed conditions has been eliminated for all practical purposes.

The present two-place, side-by-side cabin autogiro indicates a general type such as might be developed to promote the use of aircraft by the general public. The details of construction are capable of refinement and the general arrangement does not necessarily represent the ultimate form.

In autogiros of the direct control type the control stick is the inverted or hanging type, being pivoted to the cabin roof

in the center and easily accessible to either occupant. Push-pull rods connect the stick with the rotor mounting to effect control movements of the rotor hub, this arrangement giving a minimum number of joints.

When the autogiro is on the ground the control stick is moved to the forward position and secured there by a latch. The rotor is then at its low incidence, least affected by wind gusts. This position is also maintained while revving up preliminary to take-off, and when the rotor revolutions reach flight-speed, the stick is unlatched and the rotor clutch disengaged. Take-off is accomplished after a short run by pulling back on the stick in the usual manner.

From a structural point of view, the landing gear closely resembles orthodox type. The front wheels, however, are placed much further forward than has been the practice in airplane or previous autogiro construction so that a greater part of the weight is carried by the steerable tail wheel. The ground angle is also less than is usual in aircraft practice.

In a normal take-off the tail remains on the ground until the three wheels lift. This procedure does not penalize the take-off since, because with the fixed wing eliminated, it is not necessary to get the tail up to gain take-off speed (approximately 25 m.p.h.). Take-off is accomplished by increasing the rotor incidence without changing the fuselage attitude appreciably.

The low-speed characteristics and flying qualities of an autogiro of this type are adaptable to the needs of the amateur flyer. Most of the minimum forward speed can be eradicated before contact with the ground by increasing the incidence of the rotor, and the actual landing may be made with little or no forward speed.

Full control is available, even at zero forward speeds, since the rotor, which retains its lift regardless of forward speed, produces the control moments. Thus the effect of gusts may be adjusted, even when landing with no forward velocity. In flight the machine is easily controlled and maneuvered. Bungees are provided which may be adjusted for various conditions of loading and flight, so that the controls may be flown hands-off. Turns, climbs and other normal maneuvers may be practiced by a novice without danger of spins from improper handling, or of control failure from the older style control surfaces.

Blades are arranged to fold and since there are no fixed wings, the width of the storage space is determined by the span of the tail surfaces (7 ft. in the experimental machine). The blade folding

**“Differing radically from previous conventional autogiros, two new models, one an open cockpit type, the other a cabin job, have just been demonstrated to the aviation industry in the United States by Kellett Autogiro Corp., and Autogiro Company of America, respectively. In these models, wings, ailerons and elevators have been eliminated and use of the rudder is optional with the pilot. Three-bladed, folding rotor systems have replaced the rigid, four-bladed units previously used. Control is maintained through inclination of the entire rotor system, which is so mounted as to pivot on a universal axis in accordance with the conventional movements of the control stick. This new control system provides positive control of the craft at all times and under all conditions ranging from vertical descent and no forward speed to the maximum speed condition...”**

**RE: excerpt from a 1934 Aero Digest article (left)**

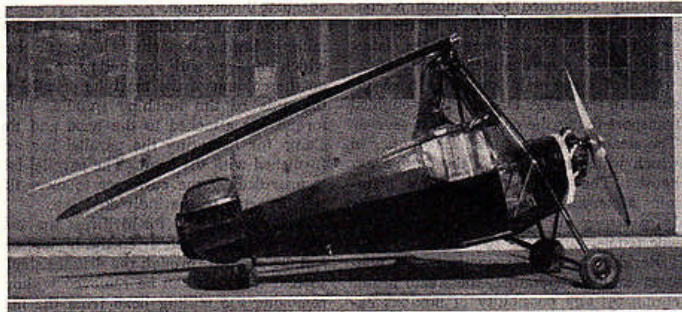

Side view of Pitcairn wingless two-place cabin autogiro with rotor blades folded

***“...Direct control means that the entire machine is controlled directly through its sustaining mechanism, or rotor, without the aid of ailerons, elevators, rudder or other surfaces subject to extreme changes in effectiveness with each change in forward speed. In the first American model a rudimentary rudder is used but will be dispensed with on instruction machines. The conventional rudder has proven unnecessary for ordinary flight within the entire speed range. This speed range is now from 17 to 195 m.p.h. with the experimental machine which has been under development by the Autogiro Company of America since April, 1933, giving a factual ratio of better than 6:1. Performance measurements have been made on days as nearly windless as possible, and corrected by averaging the results of flights both with and against the wind. As evidence of the low speed performance, a man can outrun the machine under ordinary conditions...”***

**RE: Aero Digest, 1934**

***“...the performance of the experimental direct control ‘giro shows more markedly different characteristics as compared with the other ‘giros than was the case as between the first production autogiros and airplanes. Having eliminated the rudder, the factor of coordination between stick movement and rudder bar has disappeared from instruction, and ‘crossing controls’ is eliminated. The control-differential between high and low speed conditions has been eliminated for all practical purposes...”***

**RE: Aero Digest, 1934**



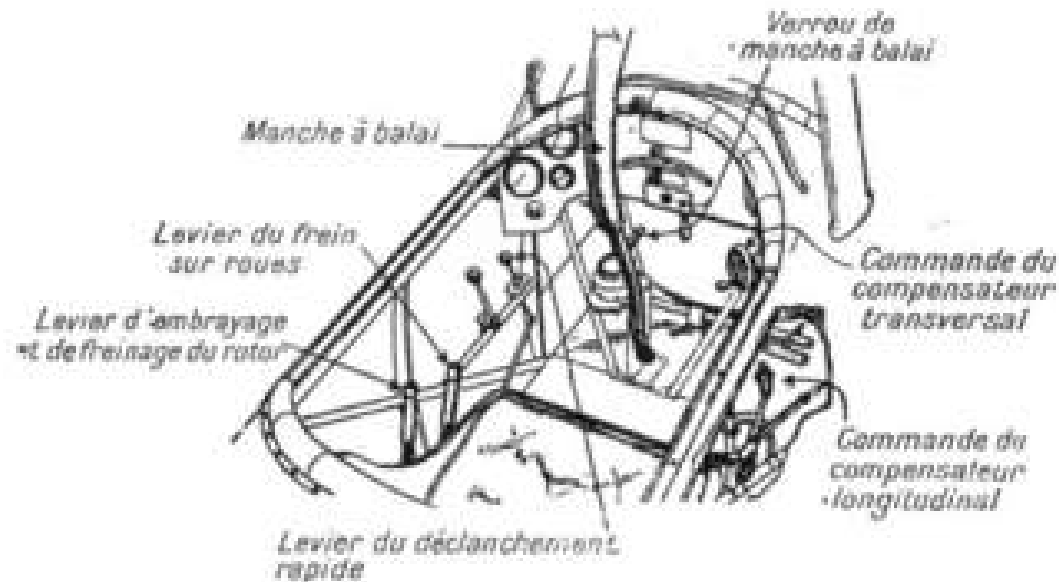

**“...In autogiros of the direct control type the control stick is the inverted or hanging type, being pivoted to the cabin roof in the center and easily accessible to either occupant. Push-pull rods connect the stick with the rotor mounting to effect control movements of the rotor hub, this arrangement giving a minimum number of joints. When the autogiro is on the ground the control stick is moved to the forward position and secured there by a latch. The rotor is then at its low incidence, least affected by wind gusts. This position is also maintained while revving up preliminary to take-off, and when the rotor revolutions reach flight speed, the stick is unlatched and the rotor run by pulling back on the stick in the usual manner...”**



**Aero Digest, 1934. Control diagram (top, in French) and view of the Cierva<sup>192</sup> C.30's cockpit (bottom)**

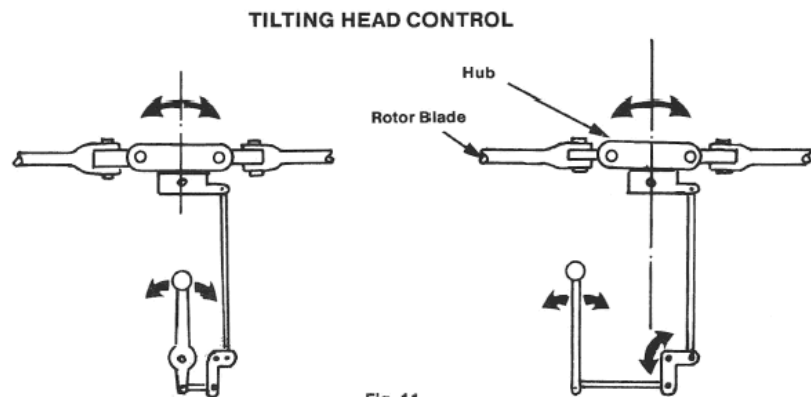

Fig. 11

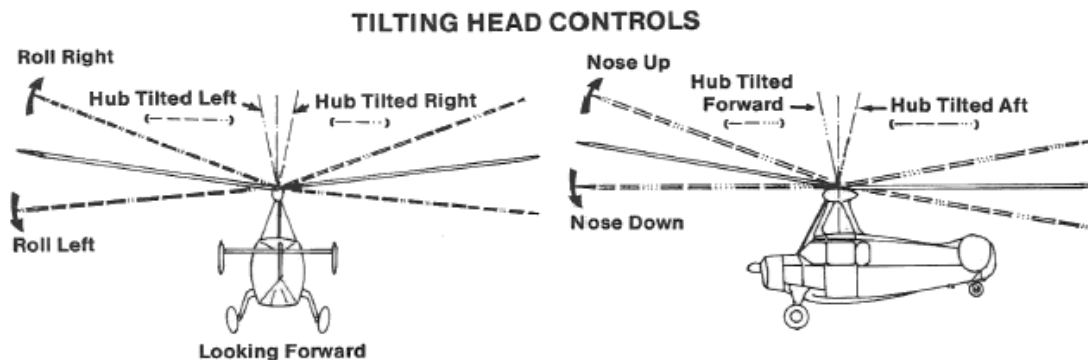
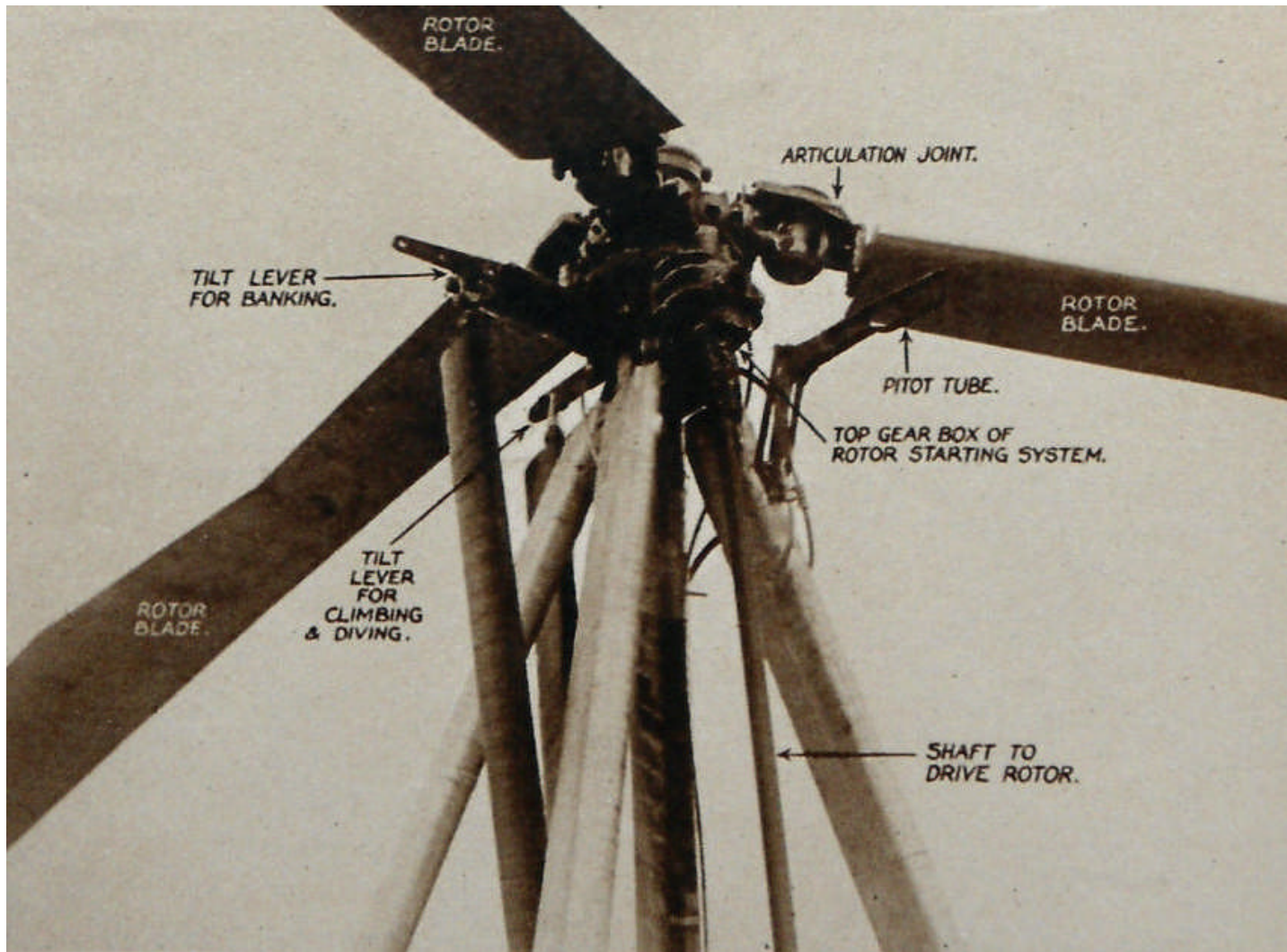

Fig. 12

**Juan de la Cierva** began his experiments with the rotor providing lateral control, but he abandoned it in favor of the airplane-type control surfaces. All the Autogiros delivered in the *United States* from 1931 through 1934 had airplane type control surfaces. Soon Cierva's Autogiros were equipped with lateral control provided by the rotor and at the same time, the rotor also controlled the Autogiro longitudinally. All this was accomplished with a simple principle; tilting the rotating axis of the rotor in the direction that control was wanted. The system was ingeniously simple. The control stick moved the rotor hub directly (fig. 11, at left), through only one or two belcranks to provide the mechanical advantage so that the loads in the control stick were only a few pounds (fig. 12, at right). The rotating part of the rotor system weighed about three-hundred pounds. With this mass spinning at 200 or more rpm, a powerful gyroscope was attached to the hand of the pilot. Any out-of-balance of the rotor was fed back to the pilot's hand via the control stick.



July 31, 1945.

J. DE LA CIERVA  
ROTOR-EQUIPPED AIRCRAFT  
Filed Dec. 6, 1932

2,380,580

17 Sheets-Sheet 6

Fig. 9.

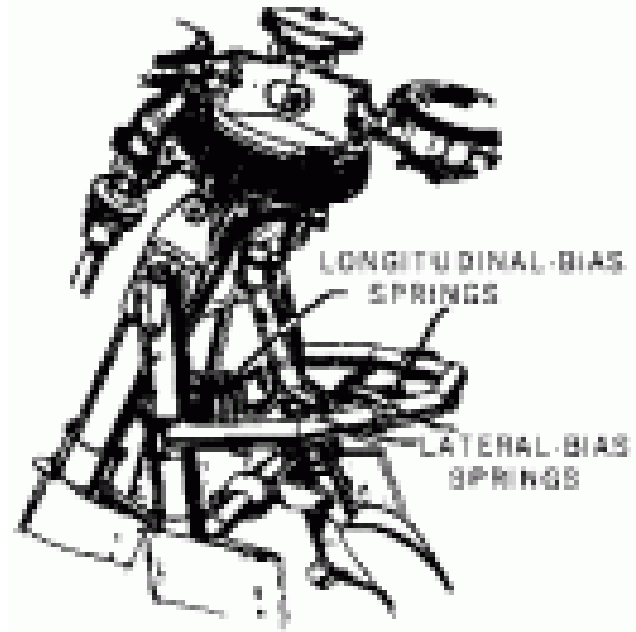
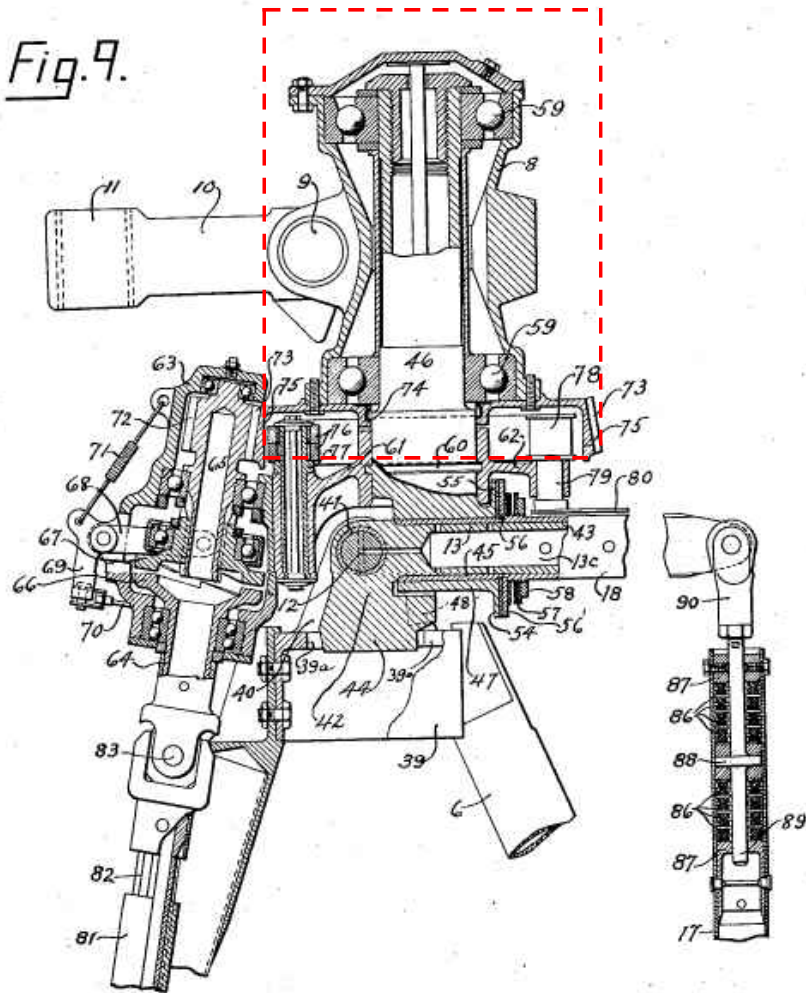

Many of the control difficulties of the Cierva C.30 were the result of direct control (via rotorhead tilt) combined with offset flap hinges. The C.30 flap hinges were crowded together as close as possible (note the hourglass shape of the C.30 rotorhead in the patent drawing at left). Without doglegging or interleaving, central flap hinges were not possible. In addition, the high stick force (resulting from flap hinge offset) masked the stabilizing effect of excess pitch pivot offset balanced by trim spring/s (above).

Fig 4

INVENTOR  
*Juan de la Cierva*  
 BY *Stratton & Peckner*



***“...From a structural point of view, the landing gear closely resembles orthodox type. The front wheels, however, are placed much further forward than has been the practice in airplane or previous autogiro construction so that a greater part of the weight is carried by the steerable tail wheel. The ground angle is also less than is usual in aircraft practice...”***

***Aero Digest, 1934***

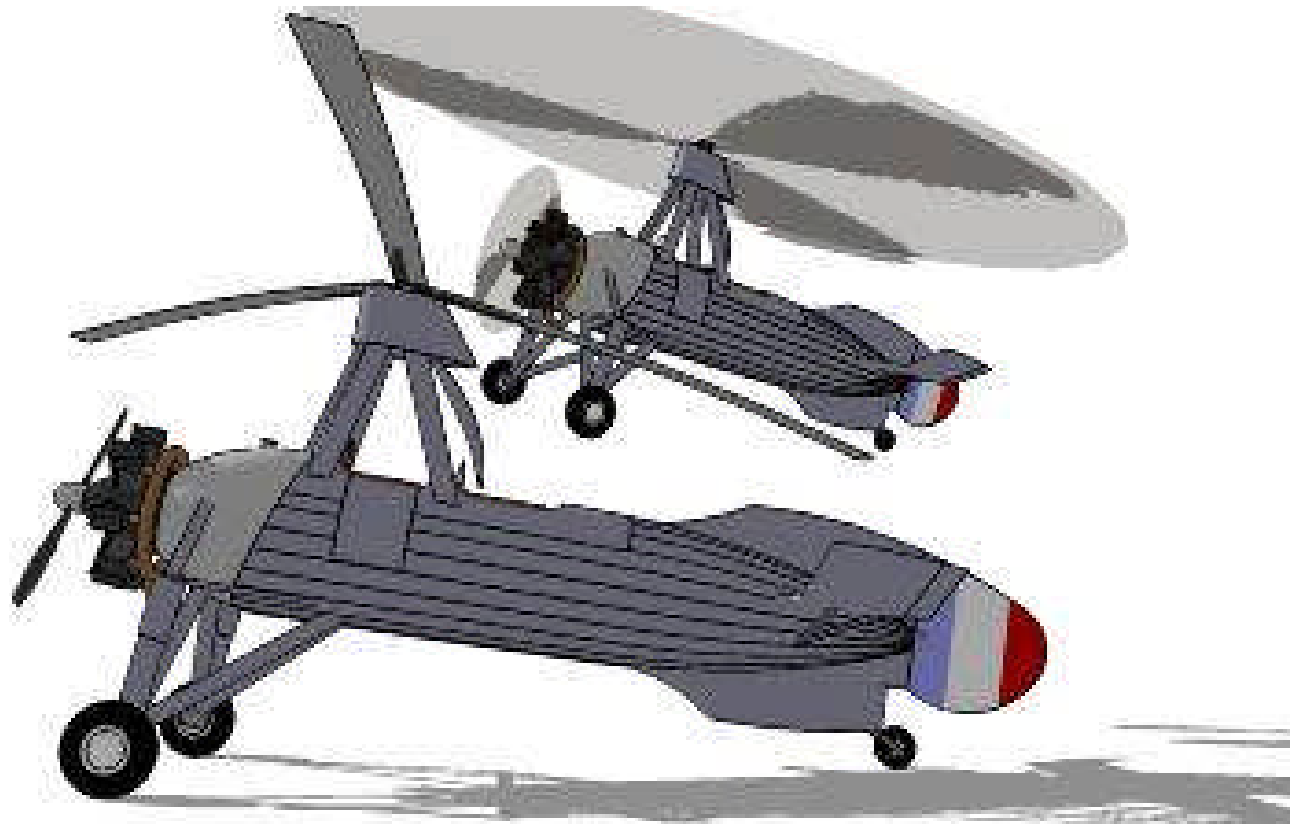

***“...In a normal take-off the tail remains on the ground until the three wheels lift. This procedure does not penalize the take-off since, because with the fixed wing eliminated, it is not necessary to get the tail up to gain take-off speed (approximately 25 m.p.h.). Take-off is accomplished by increasing the rotor incidence without changing the fuselage attitude appreciably...”***

***Aero Digest, 1934***

***“...The low speed characteristics and flying qualities of an autogiro of this type are adaptable to the needs of the amateur flyer. Most of the minimum forward speed can be eradicated before contact with the ground by increasing the incidence of the rotor, and the actual landing may be made with little or no forward speed. Full control is available, even at zero forward speeds, since the rotor, which retains its lift regardless of forward speed, produces the control moments. Thus the effect of gusts may be adjusted, even when landing with no forward velocity. In flight the machine is easily controlled and maneuvered. Bungees are provided which may be adjusted for various conditions of loading and flight, so that the controls may be flown hands-off. Turns, climbs and other normal maneuvers may be practiced by a novice without danger of spins from improper handling, or of control failure from the older style control surfaces. Blades are arranged to fold and since there are no fixed wings, the width of the storage space is determined by the span of the tail surfaces (7 ft. in the experimental machine)...”***

***Aero Digest, 1934***



AUTOGIRO





**Above: caption: “An aeroplane without wings, elevators, or ailerons – the ‘direct control’ autogiro. Mr. de la Cierva landing with the tail wheel of his machine touching ground first – the rest of the aircraft then sinking slowly to earth.”<sup>200</sup>**

# Miss Champion

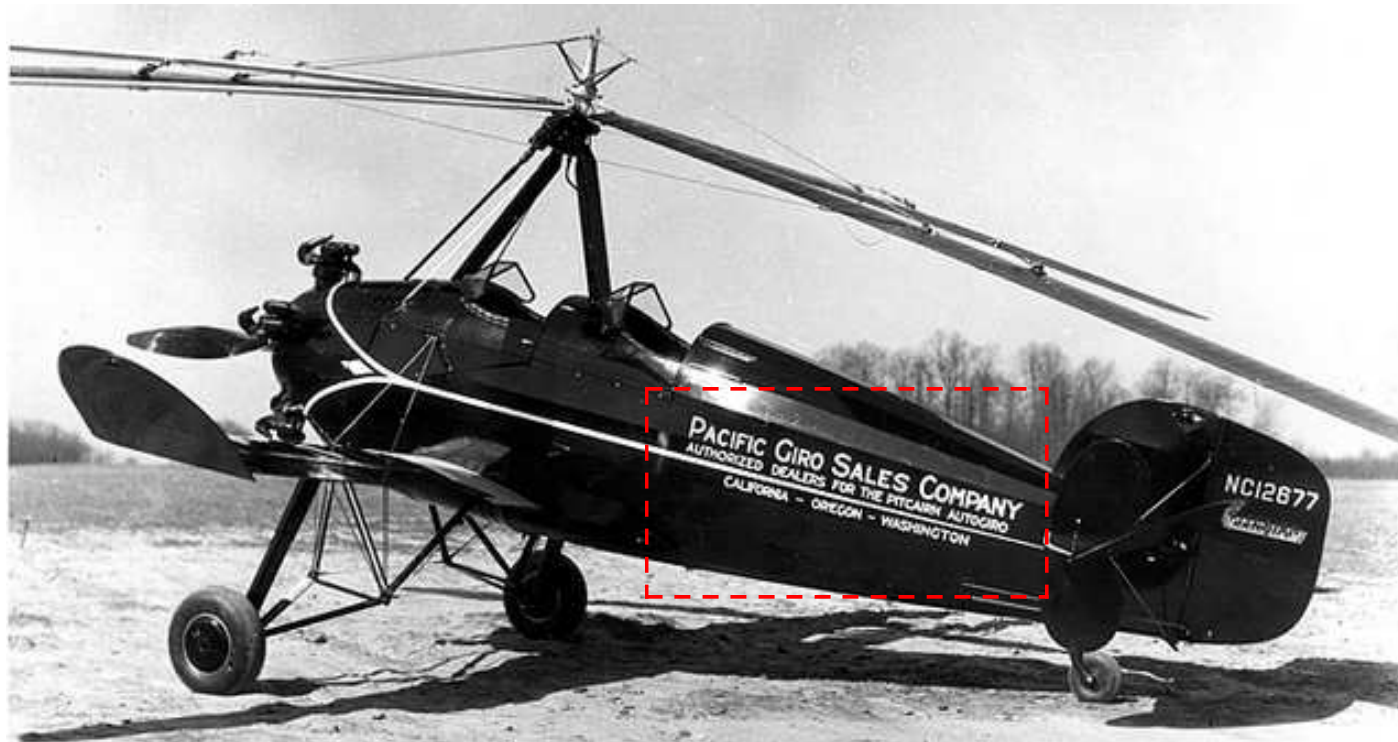

In 1929, aircraft pioneer *Harold F. Pitcairn* started building Autogiros in *Pennsylvania*. One of his first successful designs was the *PCA-2*. Only two *PCA-2* Autogiros exist today; one on static display in the *Henry Ford Museum* in *Dearborn, Michigan* (the *Detroit News* three-seater), and the flight-worthy “*Miss Champion*” (owned by *Steven Pitcairn*). *Miss Champion* came off the line at the *Pitcairn Aircraft Company* in June 1931. The type was very much in the public eye as two months earlier *Amelia Earhart* had flown one to an altitude record of 18,415 feet on April 8<sup>th</sup> 1931 and Pitcairn test pilot *Jim Ray* landed one on the *White House* lawn on April 22<sup>nd</sup> 1931.

Above: the *PCA-2* was the first rotary-wing aircraft to achieve type certification in the *United States* and was used in a number of high-profile activities. It was Pitcairn’s first autogiro design to sell in quantity, having a conventional design for its day; an airplane-like fuselage with two open cockpits in tandem and an engine mounted tractor-fashion in the nose. The lift by the four-blade main rotor was augmented by stubby, low-set monoplane wings that also carried the control surfaces. The wingtips featured considerable dihedral to act as winglets for added stability.



Knowing that Autogiros attracted attention wherever they flew, the *Champion Spark Plug Company* decided to buy one of the *PCA-2* Autogiros and use it as a flying billboard to advertise their product. The company bought serial number “27” (left) and painted it dark blue with bright yellow rotor blades and wings, and then put a large “Champion” logo on the side (above L&R). The aircraft immediately became known as “Miss Champion” and was put to use advertising Champion spark plugs all over the country.<sup>203</sup>

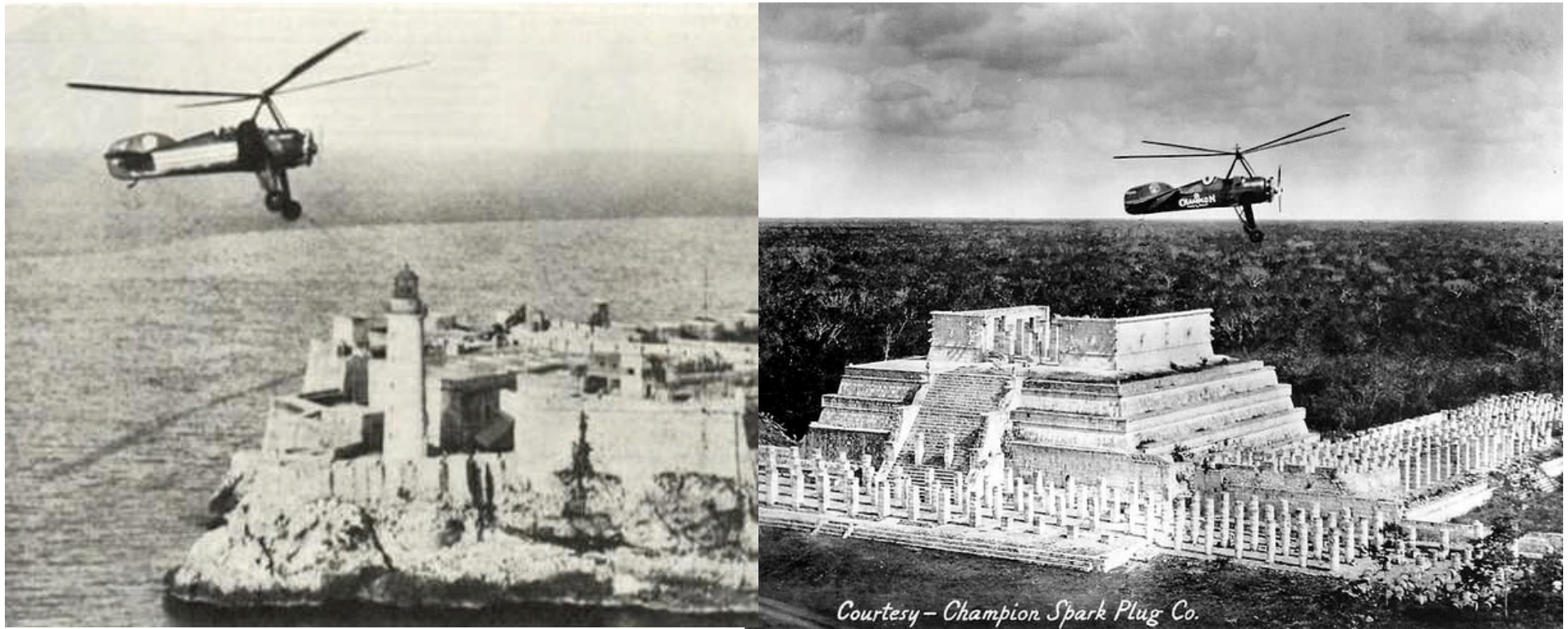

**Pilot *Lewis Yancey* flew *Miss Champion* over 6,500 miles, visiting twenty-one states and thirty-eight cities with the 1931 *Ford National Air Tour*. Everywhere the Autogiro flew it was the main attraction. In January 1932, Captain Yancey flew *Miss Champion* over three-hundred miles from *Miami, Florida* to *Havana, Cuba* (left). From there he flew across the *Gulf of Mexico* to Mexico's *Yucatan Peninsula*, where he used the Autogiro to help archeologists explore *Mayan* ruins (right). The Autogiro's slow flight and landing characteristics allowed the archeologists to make many discoveries they might never have found otherwise.**





After returning to the U.S., the *Champion Spark Plug Company* retired *Miss Champion* at the end of 1932. Soon after, she was placed on exhibit at Chicago's *Museum of Science and Industry*. After WWII the museum transferred *Miss Champion* to a small museum in *New Jersey*. She eventually wound up in a barn gathering dust until it was rescued by *Steve Pitcairn*, Harold Pitcairn's son, in 1982. Steve had *Miss Champion* restored to flying condition and flew her to the *Oshkosh, Wisconsin* fly-in in 1986. In September 2005, *Miss Champion* joined the permanent collection of the *EAA AirVenture Museum* in Oshkosh, where she is now on public display (above L&R) as a tribute to rotary-winged flight. 206





# Part 3

# Flying Craft of the Future

***“I have just had the biggest thrill of my twenty years of flying. I have piloted an autogiro. And I have seen this amazing windmill plane ‘do the impossible.’ It is, I am positive, the flying craft of the future...”***

***Assen Jordanoff, 1931***



**Above:** caption: "James Ray, right, explains to Jordanoff the mechanism of the new plane's windmill vanes"



**Above:** caption: "Pulling out the knobs on the instrument panel connects the vanes with the motor"

**Right:** caption: "Jordanoff, in cockpit beneath drooping vanes, ready for his first autogiro flight. The autogiro, except for the horizontal windmill vanes overhead, has an appearance of an ordinary plane."

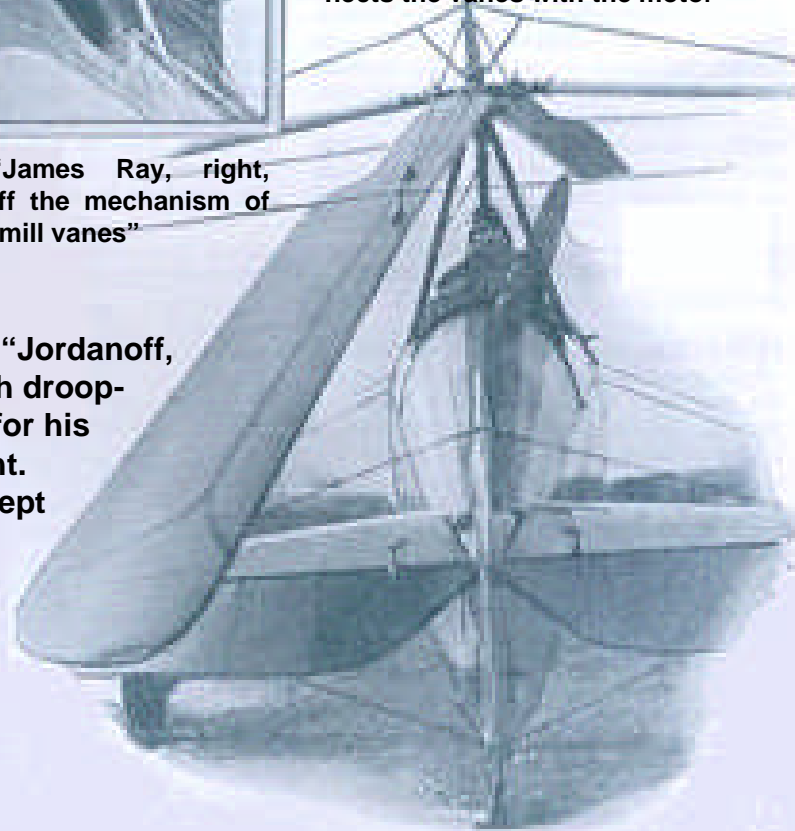

**"...At Pitcairn Field, fourteen miles from Philadelphia, Pa., James Ray, chief test pilot for the Pitcairn-Cierva Company, explained the design of the strange machine and took me for a passenger hop. We landed at the far side of the field. The spinning windmill over our heads slowed down. Its four yellow vanes, long and slender like blades of grass, drooped to a standstill above the bright green fuselage. Ray climbed from the rear cockpit. 'All right,' he said, 'you can take her up now.' I settled into the pilot's cockpit and buckled the safety strap. Ahead of me, at the nose of the conventional fuselage, was a 225-horse-power Wright Whirlwind engine and its steel propeller. Beneath me was the small black stabilizing plane with ailerons and curiously uptilted ends. At the rear were the usual tail surfaces of an airplane. But above me was the striking feature of the strange machine..."**

**Assen Jordanoff, 1931**

# Aeronautical Bulletin

PUBLISHED IN THE AIRWAYS SECTION,  
OFFICE OF THE CHIEF OF AIR SERVICE, WASHINGTON, D. C.

No. 431 STATE SERIES FEBRUARY 2, 1926

## PENNSYLVANIA

PHILADELPHIA PITCAIRN FIELD

(Superseding Bulletin No. 302)

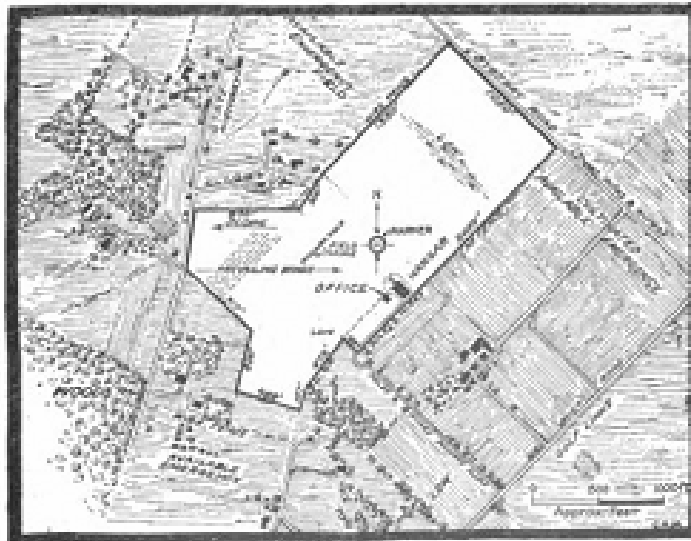
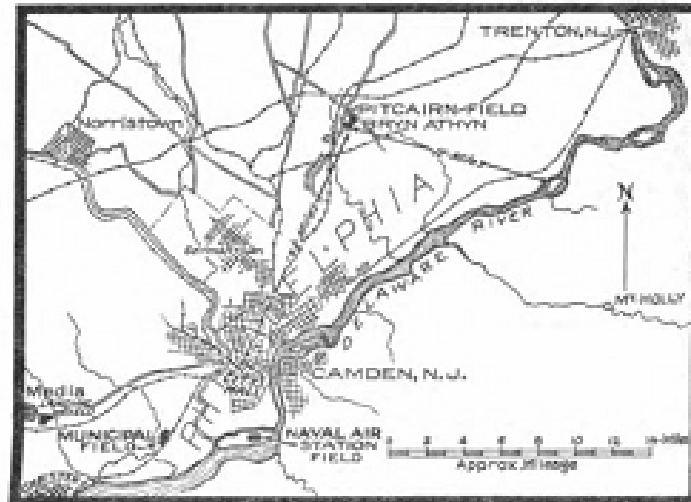

### Information on Pitcairn Field, near Philadelphia, Pa.

**CLASS.**—Commercial. Communicate with H. F. Pitcairn, 2115 Land Title Building, Philadelphia, Pa.

**POSITION.**—One mile northeast of Bryn Athyn, in lower Moreland Township, Montgomery County, Pa.; adjacent to Fox Chase and Huntingdon Turnpike at the intersection of Byberry Road. Latitude,  $40^{\circ} 8'$ ; longitude,  $75^{\circ} 3\frac{1}{2}'$ ; magnetic declination,  $8^{\circ} 45'$  west of true north. Altitude above sea level 300 feet.

**DESCRIPTION.**—Approximately 2,600 feet long by 1,000 feet wide, with an extension of 500 feet in the direction of the prevailing wind; total area is approximately 70 acres. Low wire fences surrounding field. Natural sod. Hard smooth runways in all directions from marker; runway in direction of prevailing wind is 1,400 feet long; field can be used at all times except during deep snow.

**OBSTRUCTIONS.**—Telegraph wires along road on northeast and approaching field hangar; groups of trees on the south, southwest, west, and northwest approaches. Open approaches on the north, northeast, east, and southeast.

**SIGNALS AND MARKINGS.**—Marked with white circle showing compass points and name of field. Wind cone on hangar. The Bryn Athyn Cathedral and the academy school buildings with red roofs are conspicuous landmarks from the air.

**ACCOMMODATIONS.**—Hangar with 60-foot bay; personnel in charge of field always available; accommodations for personnel in Bethayres, 1 mile from field; main highway, Philadelphia & Reading Railroad, and bus connects field with Philadelphia and other points.

**REPAIR FACILITIES.**—Available at field for rigging of planes; shops near by for other repairs.

**STORES.**—Gas, oil, and water at field for Government or commercial aircraft.

**COMMUNICATIONS.**—Telephone at field; telegraph at Bryn Athyn station.

**METEOROLOGICAL DATA.**—Available at Weather Bureau station, Philadelphia, Pa. Prevailing wind from west.

**REPORTED.**—October 18, 1924, by Harold F. Pitcairn.

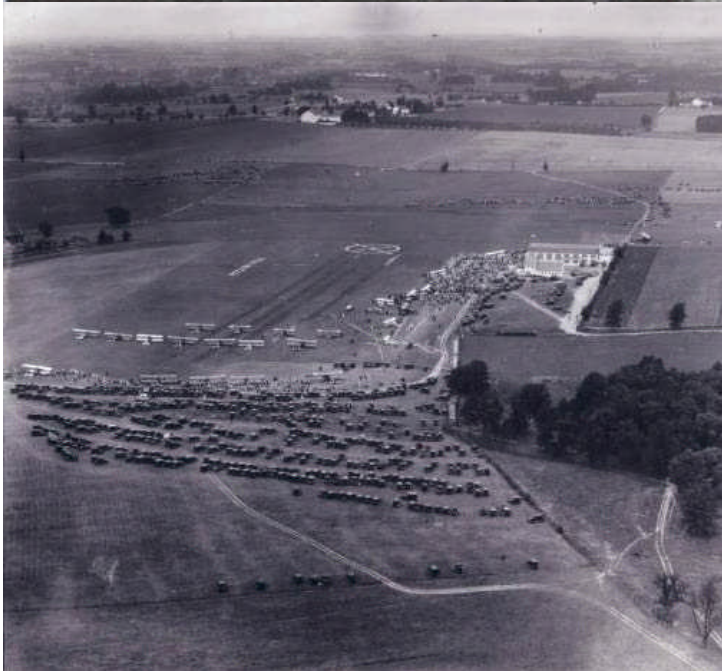

***“...Harold F. Pitcairn, president of Pitcairn Aviation, Inc., is a pilot, and also a director of National Air Transport, Inc. The Pitcairn Field is at Willow Grove, Pa. Here are a factory, hangars and ten airplanes. During the first sixteen months of operation by Pitcairn Aviation, Inc., no passenger has suffered the slightest discomfort. In 1925, Mr. Pitcairn's ships made 5,314 flights, covered 63,000 miles and carried 4,168 passengers...”***

***Aircraft Yearbook, 1926***

**Above: caption: “Pitcairn Aircraft, Inc. manufacturing facility, ca. 1930”**

**Left: caption: “Air Meet held at Pitcairn Field, Bryn Athyn,<sup>212</sup> PA, 1925”**



DATE \_\_\_\_\_

*Souvenir of Your Flight in a Pitcairn Plane*

*Pitcairn Aviation*

OF PENNSYLVANIA, INC.

Pitcairn Field, Willow Grove, Pa.

No. 36452

GLOBE TICKET COMPANY, PHILADELPHIA



***Pitcairn Field*** was founded by ***Harold Frederick Pitcairn*** (left), one of the movers and shakers during the ***Golden Age of Aviation***. Born in 1897, he was the youngest son of ***John Pitcairn***, co-founder of the ***Pittsburgh Plate Glass Company***. His airfield actually occupied two sites. Around 1916, it became an official airport at a site in ***Bryn Athyn, PA***. The second site, at ***Willow Grove, PA***, was established around 1926. The first site was small, but active. It offered flight training, air shows and pleasure flights. The second airfield site (a much larger area) satisfied the need to accommodate expanding flight instruction, sightseeing flights, airmail operations and aircraft manufacturing (some manufacturing operations remained at Bryn Athyn).

**Harold Pitcairn** took an early interest in aviation and, inspired by the first flight of the *Wright Brothers* in 1903, he began flight training as an air cadet in the closing days of WWI (he would eventually earn a pilot's license signed by *Orville Wright*). As a teenager, Pitcairn developed a fascination with the possibilities of rotary-wing aircraft and studiously followed news of Juan de la Cierva's progress. In 1924, he established himself in the aircraft manufacturing industry by building rugged biplanes, one of which; the *PA-5 Mailwing*, was to gain a legendary reputation among pilots who flew the early airmail routes (it used square rather than round tubing for the airframe giving it greater strength and durability). Nonetheless, Pitcairn pursued his dream to enter the then highly dubious field of rotary-wing aviation. In 1925 and 1926, he traveled to *England* for discussions with Cierva about either license-building Autogiros or using them as the basis of his own helicopter designs. While there with his engineer *Agnew Larsen*, Pitcairn viewed film footage of the aircraft in operation. They observed that, while the Autogiro was capable of landing in short distances within a confined space, it also required considerable amounts of high-speed taxiing to build up sufficient rotor rpm to take-off. Clearly, the ability to land short was of little value without the capability to take-off from the same terrain. Nonetheless, Pitcairn remained interested and in the summer of 1928 he returned to England and flew in the *Cierva C.8*, which greatly impressed him. A rope sling pulled by a ground crew spun the rotor of to near take-off rpm, which meant that less taxiing was required before a take-off (only 100-feet). Pitcairn decided to purchase one of the experimental *Cierva C.8W* as a test-bed for his own company's fledgling rotary-wing program.





**Left:** map shows the route of Pitcairn's *Contract Air Mail* (CAM) franchise. He operated *New York to Atlanta* (CAM-19) and later *Miami to Atlanta* (CAM-25). These routes were sold by Pitcairn to *North American Aviation* on July 10<sup>th</sup> 1929 and re-named *Eastern Air Transport* on January 17<sup>th</sup> 1930 (*Eastern Air Transport* eventually became *Eastern Airlines*). Without the airmail routes, *Harold Pitcairn* was free to concentrate on production of his *Pitcairn Mailwing* biplane, which he had developed to fly the mail. But it was so popular among other pilots there was a lucrative business in their manufacture. Likewise, through another business partnership in 1928, Pitcairn began rotary-wing aircraft production in the form of the series of *Autogiros* which, along with the *Mailwing*, assured the Pitcairn name a place in aviation history. In 1942, Pitcairn sold his *Willow Grove* airfield to the *United States Navy* to support their efforts during WWII.



**Above:** caption: “I had already moved the stick,’ says Jordanoff, ‘to lift the tail, when the ship shot up”

**Right:** caption: “Jordanoff studies the great, flimsy-like vanes, held rigid in flight by centrifugal force”

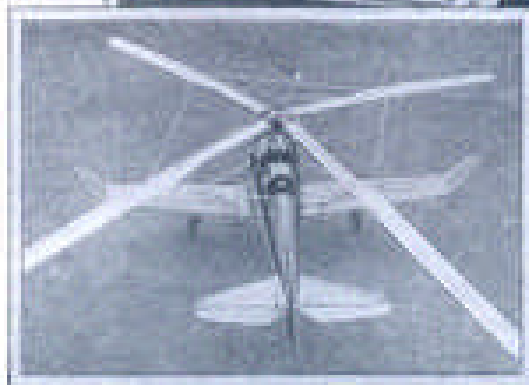

**“...At the top of a mast of three black steel tubes was the ‘rotor head’ to which the long windmill, or rotor, vanes were attached. Each vane was free to move up and down. When the ton and a half mass of the machine is supported by these vanes there is nothing to keep them from ‘coning up,’ like an umbrella turned wrong-side-out - except centrifugal force! The only bracing wires on the windmill are small ‘droop wires’ placed above the vanes to keep them from dropping to the ground and becoming damaged when at a standstill. In an autogyro, you ‘ride on centrifugal force.’ By the time the windmill is spinning at a hundred or more revolutions a minute, centrifugal force is stiffening out the vanes with a pull of more than two tons on every blade. As rigidly as though they were made of steel, this invisible bracing keeps these almost flimsy blades from folding upward...”**

**Asen Jordanoff, 1931**

**Left:** caption: “The only brace wires on the windmill are small drop wires above the vanes to keep them off the ground” <sup>217</sup>



**Above:** caption: "The windmill vanes, designed with the greatest care, are put together with the utmost accuracy in the factory"

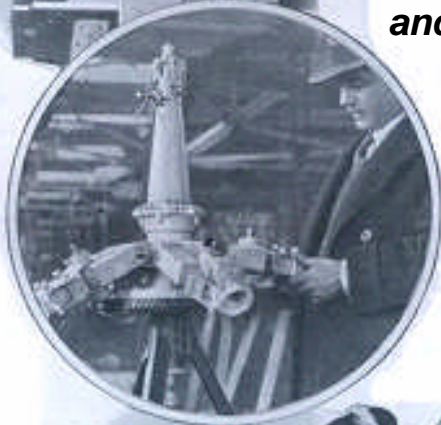

**Circle:** caption: "Jordanoff examines the manner in which the vanes are attached to the plane"

**Right:** caption: "Ray, right, explains to Jordanoff exactly what the vanes are designed to do"



*card gives the number of revolutions of the rotor at different engine speeds..."*

*Asen Jordanoff, 1931*

**Left:** caption: "Jordanoff and Ray inspect the landing gear. In his first landing Jordanoff expected a rough jolt when he hit the ground but he struck with only a slight jar"

*"...Ray pointed to a small lever at the right of the instrument board marked 'rotor brake.' That, he explained, holds the windmill from being turned by the breeze when the machine is at rest. Below the center of the instrument panel was a large knob labeled 'rotor drive.' Instead of taxiing back and forth across the field to get the rotor spinning, the Pitcairn machines are equipped with a drive shaft. Jordanoff studies the great, flimsy-like vanes, held rigid in flight by centrifugal force. From the engine, to save time, pull out the knob and the drive is connected. Push it in and it is disconnected. Push it in and it is disconnected. In the air, the windmill is never operated by the engine. Its vanes are turned by the air rushing past them. This brings up a common misconception. Many people think the autogiro is a form of helicopter; that its whirling windmill pulls it vertically upward. This is not true. Each vane is a separate airplane wing. It lifts, just as does the usual aircraft wing, by moving rapidly through the air. In the ordinary airplane, the amount of lift given by the supporting surface is entirely dependent upon the forward speed of the machine. Because the vanes of the autogiro turn at high speed, they continue to exert their lift even when the craft has come to a standstill. With the Whirlwind idling, I pushed ahead on this lever, freeing the windmill. Then I pulled out the knob. The long vanes, extending far out beyond the nose and the tail of the fuselage, began to move. Directly above the knob on the instrument panel is a round-faced dial. It shows the revolutions per minute of the rotor. Between it and the engine tachometer, a white*

***“...With my feet on the brake pedals, holding the landing gear wheels, I watched the two instruments. The needle of the engine tachometer advanced to 800. The merry-go-round above my head moved faster. The rotor tachometer showed it was turning sixty-three ‘revs’ a minute. When the Whirlwind was turning 1,000, the rotor was making seventy-nine. The machine rocked and vibrated as the forty-eight-foot windmill speeded up. Faster and faster the reflections of the vanes raced across the glistening black surface of the stabilizing wing. On sunny days, Ray told me, the checkered light and shadow made by the whirling rotor sometimes distracts a pilot unfamiliar with the machine. Now the whistling sound of the rotor was drowned in the roar of the whirlwind. It was bellowing at 1,500 revolutions a minute. The windmill was streaking around at 118. I was ready to take off. I shoved in the knob of the rotor drive. Hereafter, the air striking the vanes would prevent them from slowing down. I slipped my feet from the brake pedals to the rudder pedals. The released ship raced down the field. I had hardly moved the stick to lift the tail when the ship seemed snatched into the air. An ordinary airplane runs several hundred feet before it takes off, often at a mile a minute speed. The autogiro gets off in less than thirty yards and takes to the air at twenty-five miles an hour. I was climbing at a steep angle. The fact that an autogiro will take off at an angle from fifty to ninety percent steeper than an airplane has led it to be hailed as the ‘back yard plane’ of the future. Any plot 400 feet square, I was told, will make a four-way flying field for a ‘windmill plane.’ Already, a five-passenger cabin autogiro is under construction in England for landing and taking off on roof tops and small plots in large cities...”***

***Assen Jordanoff, 1931***



**Robert B.C. Noorduyn** had joined the *Pitcairn Company* as executive engineer in February 1932 at the commencement of the *PA-19* project, the largest Autogiro ever produced – it was equaled only by the *C-34* prototype constructed in *France* by *SNCASE* in March 1939, which never advanced beyond the testing phase. The stated goals of the “Cabin Autogiro” were strength, reliability, ease of maintenance, comfort, appearance and luxury. The prototype *PA-19* was first flown by *Jim Ray* in September 1932. When introduced to the public on October 19<sup>th</sup> 1932, the Cabin Autogiro was received with acclaim. It “rivalled the luxurious comfort of fine automobiles, suitable for women in skirts and older passengers.” Even though the *PA-19* rivalled passenger airplanes in terms of comfort (a far cry from the basic open cockpit models), only five were built and was commercially unsuccessful.

Above: caption: “The Pitcairn *PA-19* Cabin Autogiro was the largest American Autogiro built. Five<sup>220</sup> were constructed but it failed to find a market due to the depression.”



***“...For private owners, little machines with ten-foot vanes are entirely practicable, designed with vanes that fold together like the blades of a jackknife so the machine can be stored in an ordinary garage. At an altitude of 600 feet, I leveled off. I had the queer sensation of flying a plane with the wings gone. I glanced upward. The vanes of the rotor were still milling around at dizzying speed. The air was bumpy, filled with up and down currents. But the flexible structure of the machine ‘ironed out’ these ruts of sky travel. The vanes ‘give’ just enough to cushion the drops. Only occasionally did I have to move the standard airplane controls by which the machine is guided. The plane almost flew itself...”***

***Assen Jordanoff, 1931***

**Top: caption: “A Cierva autogiro flown by H.F. Pitcairn high above the Bryn Athyn Cathedral”**

**Bottom: caption: “It lands in the length of its own shadow”**



***“...I pulled back the stick and climbed to 1,200 feet. An autogiro’s ceiling is around 20,000 feet; its high speed, over two miles a minute. Cierva, its inventor, is planning a racing autogiro which is expected to pass the 200-mile-an-hour mark. The ‘windmill craft’ has withstood vertical dives at 140 miles an hour carrying 600 pounds of sand. It will do anything an airplane will do and, while these stunts have not been attempted yet, there is no aerodynamic reason, Ray told me, why they cannot loop the loop and fly upside down. At the top of the quick climb, I got my only scare on the flight. I leveled off suddenly. I was watching the rotor tachometer at the moment and saw the needle drop back from 115 to 105. The rotor had lost ten revolutions. Was it slowing down? I shot a glance up at it. The vanes seemed turning slower and slower. But when I glanced back at the instrument the needle was back at 115 again. Later, I learned that at the top of a fast climb, when the load on the vanes is suddenly lightened, they lose about ten revolutions. But as soon as the weight comes back on them again, they speed up. The greater the weight on the ‘windmill,’ the faster it turns. Tests have shown that there is no conceivable position in which the autogiro might be placed where the blades would cease revolving or slow down below the danger point...”***

***Assen Jordanoff, 1931***



# THE AUTOGIRO



*The C 19 Machine  
with device for starting the rotor blades.*

The Autogiro constitutes the first practical solution of the problem of completely controlled flight.

It ensures safety.

It cannot stall.

It can ascend and descend in a small area.

***“I eased back the throttle. We drifted across the sky at thirty miles an hour. Rolling Pennsylvania hills, light brown winter fields, bluish orchards of leafless trees, spread out below. I gave the Whirlwind the gun and watched the air speed indicator hand creep ahead to 50-70-90-115 miles an hour. On a cross-country flight, the autogiro can maintain a cruising speed of ninety-five miles an hour. In a flight from Philadelphia to Chicago for the National Air Races last fall, Ray covered the 700 miles in six hours and forty minutes. One after the other I tried skids, side slips, climbing turns, feeling out the machine. I found I had to press slightly harder on the rudder pedal but the stick control was more sensitive than on an ordinary plane. The ship made sharper turns at slower speeds than would be possible in the best of airplanes...”***

***Assen Jordanoff, 1931***



***“...By now I was down to 800 feet. I nosed up slightly into the wind and eased back the throttle. The thunder of the Whirlwind sank away. The rustle and whistle of the spinning vanes seemed to increase. The air speed indicator hand slid back until it was nearing twenty. I was trying a stall. Already I was far below the flying speed of the lightest plane. Subconsciously, I braced myself for the terrific downward plunge or the dizzying tail spin that follows a stall in an airplane. But nothing of the kind happened. We seemed floating in space...”***

***Assen Jordanoff, 1931***

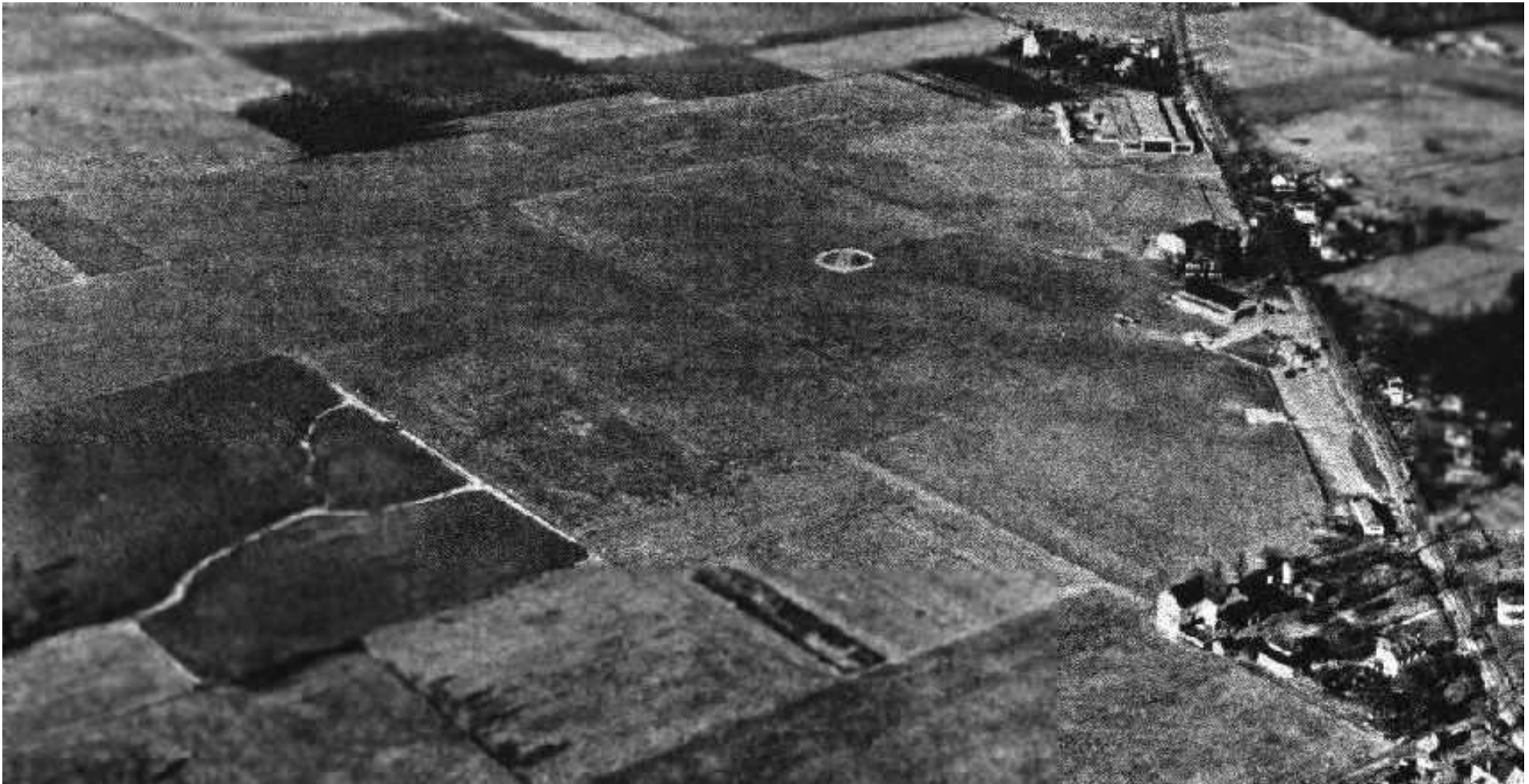

***“...I looked over the side of the cockpit. We were directly above the high water tower at the edge of the field. The yellow letters circling its top: ‘PITCAIRN FIELD,’ were slowly rising toward me. I was settling straight down through the air. The ship was coming down out of the sky like an elevator...”***

***Assen Jordanoff, 1931***

226

**Above: caption: “An aerial view looking northwest a Pittcairn Field, ca. 1930”**

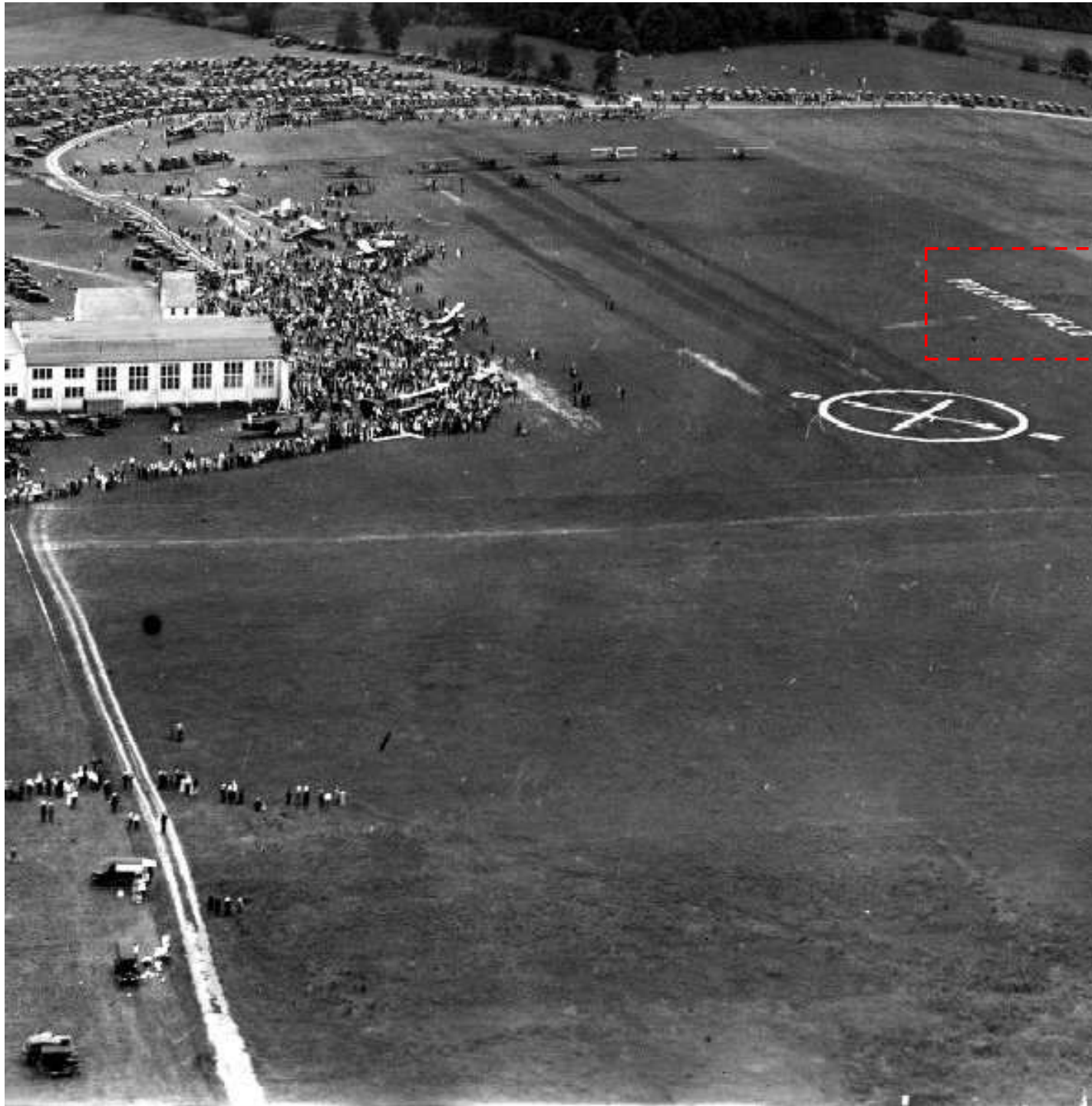

**Left:** The earliest photo of *Pitcairn Field*. A 1925 aerial view looking southwest during an Air Meet. The photo depicts the wooden hangar on the east side of the grass runway, which was marked “Pitcairn Field” in large letters (upper right, highlighted)

7585

Aero Club  
of  
Pennsylvania

FORMAL OPENING  
**PITCAIRN**  
FLYING FIELD

Bryn Athyn, Pa.

SUNDAY, NOV. 2, 1924

TAG 50 Cts.—Children under 15 yrs., 25 Cts.

Warning: *Owing to the great number of airplanes it is compulsory that all guests remain within police lines.*

***“...The faster the autogiro settles, the faster the rotor spins, just as a windmill speeds up when the breeze freshens. No matter at what altitude the machine is stalled, it merely settles. In the ‘flying windmill,’ the deadly tail spin is unknown. The reason is that the wings continue to rotate at hundreds of miles an hour and so maintain flying speed even though all forward movement of the craft has stopped. It was a tail spin that led Juan de la Cierva, the Spanish designer, to invent the autogiro....”***

**Assen Jordanoff, 1931**

**Left: ticket to opening of Pitcairn Flying Field – November 2<sup>nd</sup> 1924**



***“...Although few people know it, Cierva was a famous airplane designer before he turned to his windmill craft. He built the first successful biplane in Spain and constructed the first tri-motored tractor in the world. In 1910, when he was fourteen years old, he got into the air in a homemade glider by hiring a dozen boys at a penny apiece to pull him at the end of a long rope. Two years later, with a total capital of sixty dollars, he started his first motored machine. The propeller was carved from the wine-soaked wood of an old bar taken from a deserted inn. It was several pounds heavier on one end than the other, so the plane flew like a bucking broncho - but it flew, Later, in 1918, he designed a huge, eighty-foot, tri-motored passenger plane that was flown successfully. But the over-confident pilot stalled it in landing and spun into the ground. That spin led Cierva to believe that something was wrong with the entire system of airplane flight. He sought other means of getting off the ground; tried wing-flappers and helicopters. Finally, he worked out the whole theory of the autogiro on paper before he built even a model. His first machine was built in 1920. It and several others that followed failed to fly. It was not until he gave the vanes complete freedom and depended upon centrifugal force that he succeeded. The first flight over a closed circuit in an autogiro was accomplished at Madrid, Spain, in 1923...”*** <sup>229</sup>

***Assen Jordanoff, 1931***



***“...At the Pitcairn factory, machines have been flown practically every day for the past two years. They have been tested thoroughly and are to be put on the market in quantity production this spring...”***

***Assen Jordanoff, 1931***



**Top:** caption: “Over the Skyscrapers of Philadelphia. Here, in a limbo of light, the autogiro soars through heaven with the imperturbability of airplane or of albatross. Its frail-looking pinions cushion it over the air bumps that exist above the city’s pinnacles”

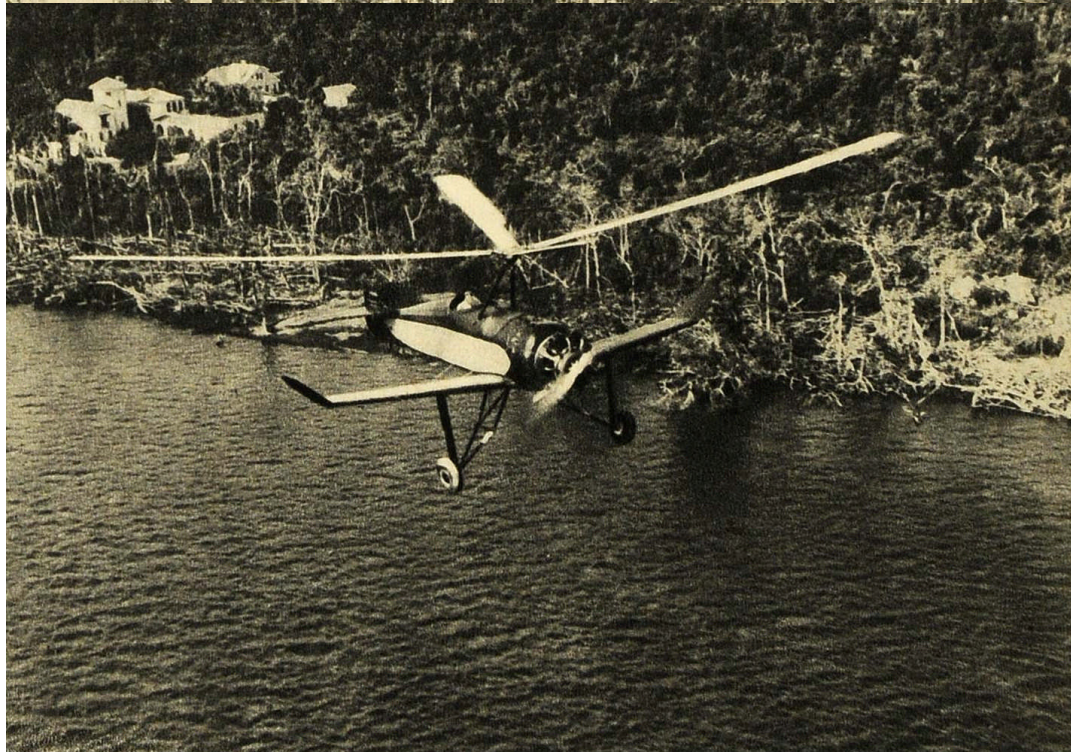

**Bottom:** caption: “Over the Coral Shores of Florida. In January of this year, an autogiro paid a visit to Miami. Secure in its peculiar ability to alight easily and safe from the danger of falling into spins at low altitudes, this petrodactyl of modern mechanics skimmed impudently over the waters of the Gulf Stream, flitted across the tangled greenery of subtropical forests.”



# Settling In



***“...For about 100 feet, I continued to settle toward the tower. Then I pushed the stick downward, picked up flying speed, and gave the Whirlwind the gun. I swung to the far side of the field and came in for a landing. This can be accomplished in two ways: either by gliding in, as in an airplane, or by ‘settling in’ by a vertical descent. For my first landing, I picked the one I knew best and drifted in with a long slow glide. When I was twenty feet off the ground, I pulled back the stick. The nose of the ship rose and the whirling vanes checked our forward speed just as a crow spreads its wings and checks itself as it alights in a cornfield. The autogiro is the only heavier-than-air craft that can slow down suddenly. Once Cierva took off toward a row of high trees, saw he could not clear the barrier, jerked back the stick at the last instant, and sat down seventy-five feet from the obstacles. An airplane would have crashed...”***

***Assen Jordanoff, 1931***

***Above: caption “A remarkable 1931 photo of Juan de la Cierva (inventor of the Autogiro) making a<sup>233</sup> tail-first landing of G-AAKY at Pitcairn Field, Bryn Athyn”***

***“An investigation to determine the rate of descent, the horizontal velocity, and the attitude at contact of an autogiro in landings was made by the National Advisory Committee for Aeronautics at the request of the Bureau of Air Commerce, Department of Commerce. The investigation covered various types of landings. The results of the investigation disclosed that the maximum rate of descent at contact with the ground (10.6 feet per second) was less than the minimum rate of descent attainable in a steady glide (15.8 feet per second); that the rate of descent at contact were of the same order of magnitude as those experienced by conventional airplanes in landings; that flared landings resulted in very low horizontal velocities at contact; and that unexpectedly high lift and drag force coefficients were developed in the latter stages of the flared landings. The characteristic ability of an autogiro to be landed from steep glides of approach and with very low horizontal velocities at contact with the ground has led to speculation as to the strength and shock-absorption requirements for this type of aircraft...Tests to obtain these data were made with a Pitcairn PCA-2 autogiro...The tests consisted of a series of landings arranged to cover the types that would be made by an autogiro pilot of average, or poor, ability. The investigation was conducted by the N.A.C.A. at Langley Field, Va., during the months of May and June 1933...”***

**RE: excerpt from *Technical Notes – National Advisory Committee for Aeronautics – Landing Characteristics of an Autogiro* (November 1934)**



**Above: caption: “Pitcairn PCA-2 Autogiro purchased in 1931 and used for experimentation. Owned and operated at Langley Field, Virginia by <sup>235</sup> the N.A.C.A.”**

# WINGS OF TOMORROW

---

THE STORY OF  
THE AUTOGIRO

By JUAN DE LA CIERVA and DON ROSE



---

BREWER, WARREN & PUTNAM

*“The take off in itself is effected exactly like that of an aeroplane. One may dive and climb at will, make vertical turns, and so on. The autogiro flies exactly like any aeroplane. The real sensation that I experienced was in landing. Cutting off the motor 1,000 feet directly over the field, I pulled the stick back and proceeded to fly, on my first landing, about thirty miles an hour coming into land. The descent was about an angle of 45 degrees and on touching the ground I did not roll more than ten feet without any application of the wheel brakes whatsoever. I took off again and landed to become accustomed to this strange craft. It intrigued and thrilled me. I now had enough experience to attempt a more vertical descent....it is quite a sensation for a pilot who has been flying a fast aeroplane that lands between 60 and 70 miles an hour and that must be maneuvered carefully into a field, making sure his judgment is accurately managed, to step into a machine and fly right over the center of the field, shut off his motor and then drop right straight down into the circle which marks the center of airport.”*

*Juan de la Cierva*

236

RE: excerpt from *Wings of Tomorrow*

# **Newsreel Worthy**



***“...I had expected a terrific jolt when we hit the ground. Instead, we landed with a comparatively slight jar. Even when the ship descends vertically from high in the air the jolt of landing is about that of crossing a rough railroad crossing at twenty-five miles an hour in a well upholstered automobile. Because there is no long run after touching the earth, an autogiro can sit down on rough ground, even between frozen potato rows, without damage. Any small open space, wider than the windmill, serves as a landing field. At the National Air Races, Ray was flying from Cicero, Ill., to the field where the contest was held when his engine cut out. He pulled back the stick and settled down on the pavement of a highway directly between two telephone poles, without the slightest damage...”***

***Assen Jordanoff, 1931***

***Left: caption: “July 8, 1931: An autogiro took off in front of the Capitol with Senator Hiram Bingham of Connecticut on board, headed for an afternoon of golf.”***



Publicity stunts were designed to catch the public's attention. Perhaps the most newsreel-worthy publicity stunt performed by an Autogiro occurred when a Pitcairn Autogiro landed in the parking lot on the east-side of the *U.S. Capitol Building* to pick up *Senator Hiram Bingham* to fly him to a golf outing at the *Burning Tree Country Club* outside *Washington, D.C.*

Left: caption: "Senator Hiram Bingham poses on the wing of an autogiro after returning to the Capitol from a round of golf in 1931"





Pitcairn also had the *PCA-2* photographed landing on the lawns of country estates, with many images of the aircraft landing at his own *Bryn Athyn* home: *Cairncrest*, and flying off to hunting or fishing camps. His advertising agency commissioned paintings, used for magazine and sales brochure illustrations, featuring the Autogiro landing at the country estate, the foxhunt, the dude ranch and on the country club landing field having just deposited the handsome couple heading for the tennis court.

Above: caption: "Pencil Drawing of Auto-giro in Flight over Cairncrest"

240

Left: bookplate showing Cairncrest and an Autogiro



SECURE AND PRACTICAL FOR RECREATION AND UTILITY

Open areas surrounding almost any country club offer room for the owner of a Pitcairn Autogiro to fly directly to his golf game. Requiring little room to take off and even less to land, the pilot owner can fly directly to the scene of almost any sporting event. The practicality of such use has long ago been demonstrated by those owners of the Pitcairn Autogiro who have flown to football games, race tracks, hunt meets and other social gatherings in many locations. The ability to land on and take off from any reasonably sized open ground with security frees the pilot from the necessity of seeking a safe landing only at the large airport. The 1932 Pitcairn Tandem has been refined in design for greater speed and pleasure. Improved streamlining and more engine power add to speed. Tandem cockpits that afford the full visibility so desirable to the amateur flyer, have dual controls to permit sharing the sport of flying. A demonstration can be arranged at the point where you would use your own Autogiro. Write for descriptive literature.

PITCAIRN AIRCRAFT, INC., PITCAIRN FIELD, WILLOW GROVE, PA.

PITCAIRN  
*autogiro*

***“...the day is fast approaching when country houses will have wind cones flying from their roofs to guide guests to the front lawn landing area...”***

***Cosmopolitan magazine, August 1931***

***Left: 1932 Pitcairn Autogiro magazine advertisement***

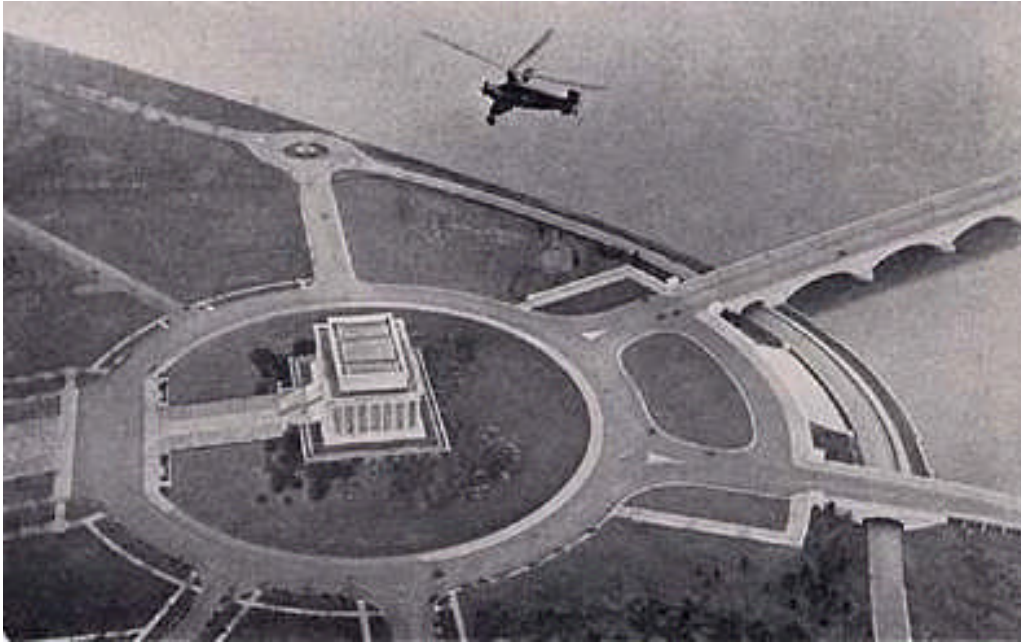

***“...In the thousands of hours that autogiros have been flown, nobody who has piloted one has been seriously injured. Once, a vane broke off high in the air and the pilot was only shaken up and bruised in landing. That accident occurred when Cierva was experimenting with rigid vanes. Since they have been made flexible there has been no repetition of the trouble...”***

***Assen Jordanoff, 1931***

***Left: caption: “Over The Lincoln Memorial Washington, D.C., February 1933”***

***“...Before the windmill lost momentum, I shoved the throttle wide open and took off on my second hop. Just clipping the tree tops, I cruised over the countryside at thirty-five miles an hour. A farmer chopping wood in a field stopped to look up. I waved and he waved back. The most fun in flying is to fly low. And that is as dangerous as dynamite in an airplane. You have to fly up at 2,000 or 5,000 feet to have a safe gliding range in case the engine stops. Such flying is monotonous. It is like passing over a huge map. People are the size of pin heads. You want to see what is going on but dare not take the chance. All this is changed with the autogiro. You can fly low and slow with safety. In case of engine trouble, you can drop down into any open space; you don't have to pick out a wide and level field. The more I flew the autogiro the more enthusiastic I became. Anyone who can learn to drive an automobile can learn to fly a windmill ship. Safety in an airplane depends more on the skill of the pilot. In an autogiro the human factor is reduced immensely. Ninety percent is taken care of by the machine itself. They told me a student could master a windmill plane in a quarter the time it takes to learn to fly an airplane. The danger of the take off is eliminated; the difficulty of landing is done away with; the menace of stalling and getting into a deadly tail spin is gone. It is the first plane designed for the average person...”***

***Assen Jordanoff, 1931***



# **When Autogiros are Everywhere!**

***“...After nearly half an hour in the air, I climbed to 1,000 feet above the center of the field and ‘settled in.’ Holding the ship level with the ailerons, I looked over the side of the cockpit and watched the yellow-brown rectangle of Pitcairn Field slowly expand as I settled toward it. A small chrome-yellow training plane scudded below me and sat down on the field with a long run, then taxied to the hangars. I was dropping slightly faster than a walk. It was like drifting down in a balloon. The earth seemed moving up to meet me. I had no sense of descent. There was no up-draft hitting my face. The spinning vanes above push down a column of air as well as act as a parachute. Fifteen feet from the ground, I pulled back the stick, dropped the tail, and we sat down on three points. The wheels made less than half a turn on their axles; we rolled hardly six inches. I had landed less than a hundred yards from the first take-off where Ray was still standing. The windmill overhead slowed down. The rotor tachometer hand touched ninety, then sixty, then forty. As they lost speed, the tips of the vanes began to drop. Finally, with the blades held up by the droop wires, the windmill came to a stop. I pulled back the rotor brake lever, locking it in place, and looked over at Ray. He grinned broadly and said: ‘Well, now you are one of the first twenty-five pilots in America to fly an autogiro.’ ‘That,’ I told him, ‘will be something to tell the grandchildren - when autogiros are everywhere!’”***





# Inside Story



***“Captain Frank T. Courtney began flying in England in 1911. During the war, he served as a member of the Royal Flying Corps. In 1919, an accident destroyed his chance of making the first nonstop flight across the Atlantic. In 1928, he attempted to fly the Atlantic from east to west. The engine caught fire in mid-ocean and he drifted for twenty-four hours. He is a famous racing pilot and has tested more new planes than any other flyer....”***

***Popular Science, October 1931***

***Left: Capt. Frank Courtney,  
test pilot extraordinaire***

## Capt. Courtney's FIVE RULES FOR TEST FLYING

- 1 . . . Weigh the plane to be sure it is in perfect balance before trying to take off. (See diagram below)
- 2 . . . Sit in the cockpit, switching on and off the ignition and fuel until these emergency movements become instinctive.
- 3 . . . Make sure the controls are hooked up correctly by "wagging" the stick.
- 4 . . . Select a large field for the initial tests so there will be plenty of room to maneuver in an emergency.
- 5 . . . Never take an untried plane up unless the air is calm.

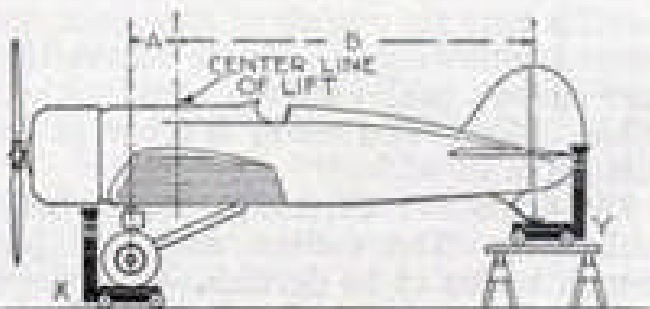

Diagram shows how to weigh an untried plane to see if it is properly balanced. Note scales at front and rear. The formula is: Weight shown by two scales under wheels, X, times distance, A, equals weight shown at Y times distance B if plane is in balance.



***"...Just for fun, the other evening, I jotted down a list of the planes I have ridden into the sky on their initial tests. It totaled more than a hundred different types. For fifteen years, I have been a freelance test pilot in England, on the Continent, and in America. During that time I suppose I must have made 10,000 test hops - possibly more than any other pilot in the world..."***

**Captain Frank T. Courtney, 1931**

**Above: caption: "This plane was built for Courtney's use in trans-Atlantic flight in 1919. He violated his rule of waiting for a calm day before making a first test flight with the result that he smashed up and lost his opportunity to be the first to fly the Atlantic nonstop."**



***“...My most fascinating adventure in test flying began one fall day in London. A relatively unknown Spaniard, Juan de la Cierva, invited me to lunch. He had brought a strange ‘flying windmill’ from Madrid, and asked me to fly it in its early tests. That was in 1925. For eighteen months afterwards, I did all the flying on the five experimental machines that led to the present autogiro. The inside story of those early days has never been told...”***

***Captain Frank T. Courtney, 1931***  
***Left: Juan de la Cierva***



***“...One of our early problems was getting the vanes spinning for the take-off. The windmill of the autogiro is not braced like the wings of an airplane. The vanes, free to move up and down, are held rigid during flight by centrifugal force pulling them outward. Aloft, the rushing air keeps the vanes spinning at sufficient speed to maintain this invisible bracing. But on the ground, the vanes must be spun up to 100 revolutions a minute artificially before the take-off can be made. This is now done through a drive from the motor. In the beginning, I had to taxi back and forth across the field to start the windmill going. Then Cierva attached knobs to the underside of the four vanes. Mechanics wound a long rope outside these knobs then ran with the end, spinning the vanes as a boy spins a top. One of the ‘mechs’ who didn’t get much fun out of running suggested tying the end of the rope to a stake and taxiing the ship away, spinning the vanes in this manner. It sounded all right and we tried it. I opened the throttle and the ship moved down the field faster and faster, the vanes streaking around over my head...”***

***Captain Frank T. Courtney, 1931***

**Above: caption: “When Courtney first tested autogiros, men pulling ropes started the windmill vanes whirling. Now the motor does that before take-off”**

***“...They were spinning at more than a hundred revolutions a minute when the end of the rope whistled through the air. There was a loud splintering crash. The ship rocked and trembled. I cut the gun and stopped. The end of the rope, whipping through the air, had sliced through the fin and rudder as cleanly as a knife!...”***

***Captain Frank T. Courtney, 1931***

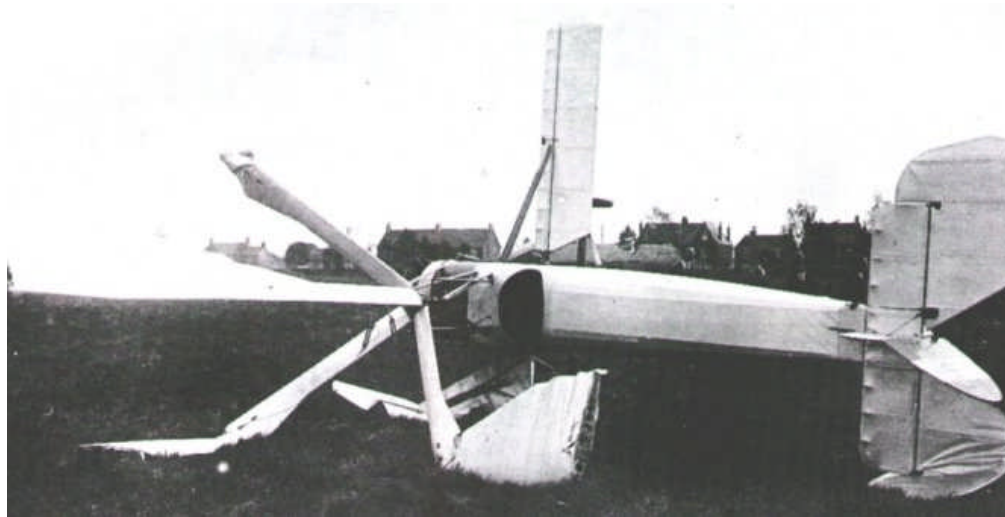

***“...Another accident in those early days taught us an important lesson. The first autogiro I flew had the windmill simply mounted on an old Avro fuselage with the landing wheels comparatively close together. In the early part of 1926, I was giving an exhibition with this machine at Paris. The sky was ugly when I took off from Villacoublay field. The wind was blowing in gusts. Only the fact that a large assemblage of dignitaries was present made us go on with the demonstration. As I circled the field, the strength of the wind increased. It was a howling, forty-mile-an-hour gale when I came down to land. The ship sat down in the teeth of the wind, not a hundred feet from the cameras. It landed squarely on both wheels. Then a side gust struck the spinning vanes, rocked the ship on its narrow landing gear, heeled it over. The long, flail-like arms threshed into the mud, Hinging it away like sparks from an emery wheel. Then the craft crumpled, lay still. I crawled out, muddy but unhurt. As a result of that spectacular crack-up, the wide landing gear, giving greater ground stability, was adopted as part of the design of modern autogiros...”***

254

***Captain Frank T. Courtney, 1931***



***“...Another improvement resulted from a hair-raising crash at Southampton, England, a few months later. Two vanes of the rotor fell off in mid-air. About 150 feet up, I noticed excessive vibration in the vanes. Picking out a long line of trees, I steered directly above them. They would break my fall in the event of a crash. At the end of the line, the vibration was no worse and I swung over the field at 125 feet. Suddenly the vibration increased. The vanes were shaking violently. I started down. At that instant, there was a loud crack above my head. The steel main spar of one of the vanes, crystallized by the vibration, had snapped. The long blade of the windmill broke free, whirled into space. I had one glimpse of it fluttering off like a broken blade of grass. After that, I saw nothing. The uneven jerking of the remaining blades rattled me about in the cockpit like a pea in a tin can. My shoulders were battered black and blue. Fifteen feet up, a second blade tore away from the reeling craft. It fell like a stone...”***

***Captain Frank T. Courtney, 1931***

***Left: caption: “Captain Frank T. Courtney flying the Cierva C.6A autogiro over Farnborough, England, October 30, 1925”***





***“...While I was in the hospital, mending half a dozen broken bones, vertical hinges in addition to horizontal hinges were fitted to the vane spars. This prevents vibration on modern machines and makes impossible a repetition of my accident. Today, the autogiro is less likely to break in the air than an airplane. By bringing out weak points, revealing needed improvements, and helping adjust and alter new machines, the test pilot plays an important part. Most of the work we do, however, is not with radically new designs like the autogiro...”***

***Captain Frank T. Courtney, 1931***

***Left: caption: “Captain Frank T. Courtney 256 (ca. 1945)”***

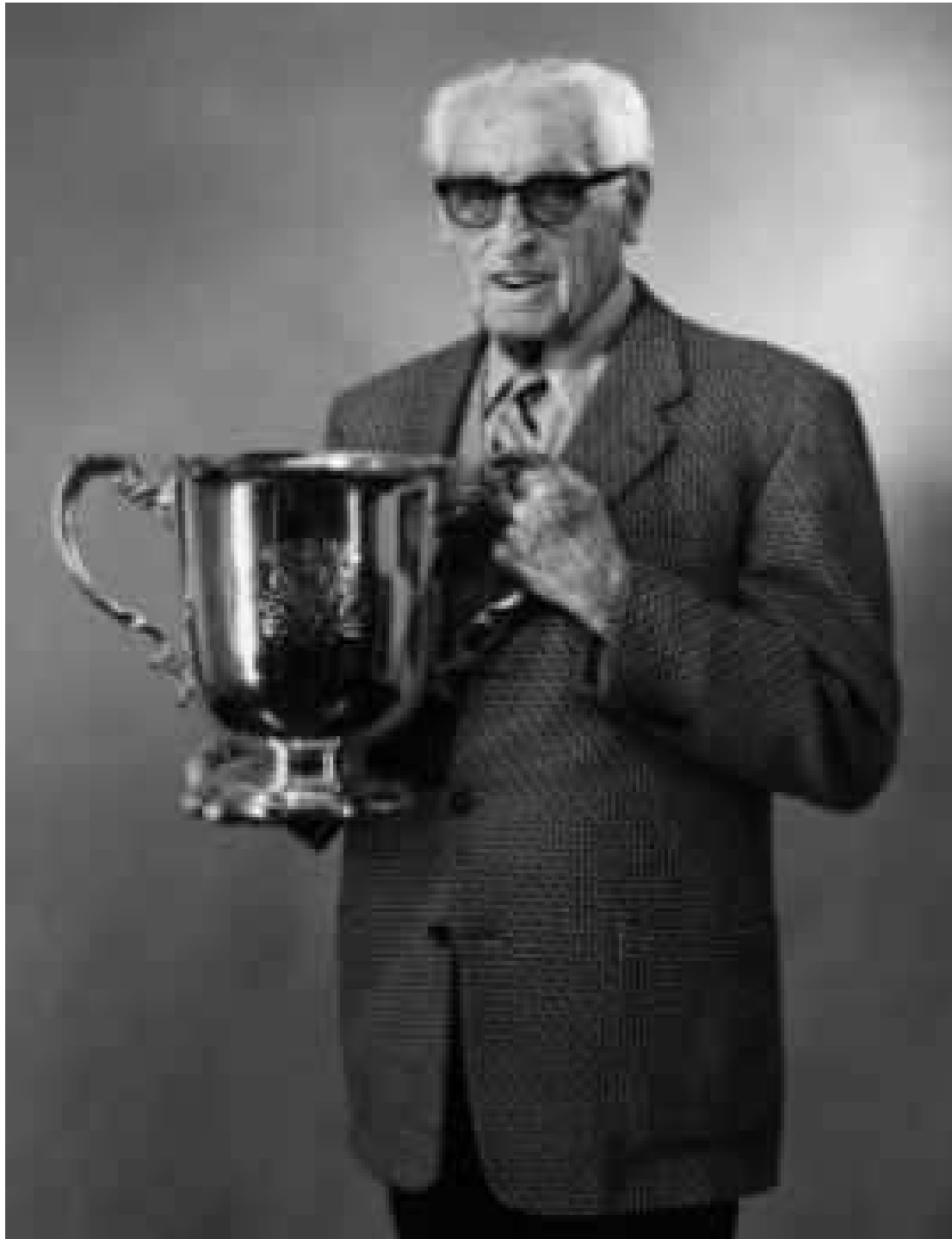

***“...A test pilot, who risks his life in untried planes, must be prepared for anything. The surprise may be a false alarm or a desperate crisis. In the world of flying men, he plays a role replete with thrills and drama, which he has to treat as ordinary mechanical happenings. He is using the sky for his laboratory in work that plays its part in bringing better planes.”***

***Captain Frank T. Courtney, 1931***  
**Left: caption: “Captain Frank T. Courtney (1894-1982) in 1972 (at the age of 78) holding the King’s Cup which he won in the 1930s. This photograph was taken at the RAF museum, Hendon, North London.”**

# The Helicogyre



*“Recent successes of Juan de la Cierva’s Autogyro airplane have directed the attention of aeronautical engineers to the possibilities of improving this type of machine into tomorrow’s perfect airplane. The aerodynamics of the autogyro are considerably more complicated than is the case with the conventional type of plane, but various features of its design, such as its ability to descend almost vertically, are most practical. On the cover of this month’s Modern Mechanics, Stewart Rouse has presented an adaptation of the autogyro suggested by a French designer and tentatively called the helicogyre. The principal difference from the autogyro lies in the installation of two motors in the ends of the revolving wings. In addition to this, the wings themselves are thickened and are generally of heavier construction than the companion pair of wings, without motors, which give fore and aft stability while the motored wings are parallel with the fuselage of the plane...”*

*Modern Mechanics, January 1930*

***“...In the autogyro a long run on the ground is necessary in taking off, to give the rotating wings time to gain speed. As implied in the name of the machine, these wings are set in motion automatically when the plane moves forward. In the helicogyre this long take off would be eliminated, the wing motors taking care of accelerating the wings, making possible an ascent which its advocates predict would be almost vertical. The addition of motors to the wings complicates the aerodynamics of the design somewhat. Light, high speed motors must be used to economize on weight. Such installation, however, entirely changes the principle by which flight is attained. The two small wings, resembling the lower wings of a biplane, are used more for directional control than for lifting power. Practically all of the lift is supplied by the revolving wings. An extremely low landing speed is a feature of the autogyro which appeals most strongly to observers. The plane seems almost to hover in the air, and when it comes down in a vertical line it stops rolling almost at the instant its wheels touch the ground. If the autogyro’s take-off ability can be made comparable to that of landing, the machine will have an ability to land in and rise from a back yard.”***

***Modern Mechanics, January 1930***

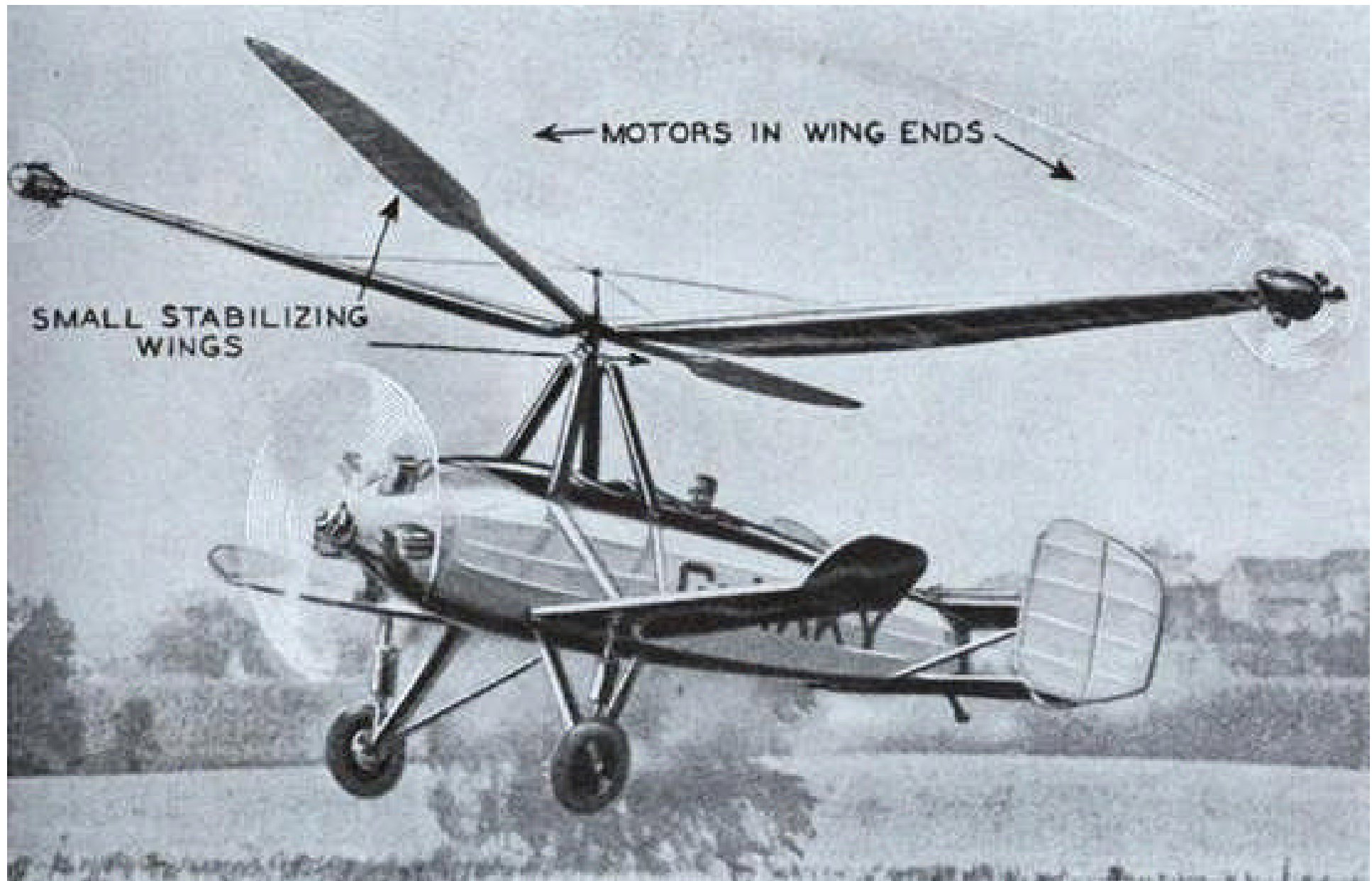

**Above: caption: “This pictograph shows a helicopter in flight, as depicted on the cover of this month’s Modern Mechanics. The helicogyre is a proposed improvement of the autogyro, with two motors mounted on the revolving wings.”**



***“As interesting as is the new type of gyro plane now undergoing exhaustive experiments in France, the method of testing is perhaps of even more interest. The trial carriage is electrically driven and attains a speed of from 60 to 80 miles an hour on rails. By means of measuring instruments on the carriage, the wind pressure, lifting power, derivation of lift, and the stresses on various parts are registered. The plane itself is of the conventional type, except for a pair of large propellers, which turn in opposite directions, mounted on a stub shaft above the plane. These propellers work by wind pressure.”***

***Modern Mechanics, January 1932***

***Left: caption: “The ‘Clinogyre BO mounted on its test carriage. The plane and carriage were invented by Bessier and Odier, of France.”***

# Trailblazer



**In about a twenty year flurry of activity, it seemed as though the Autogiro was sent to make the helicopter, for which many inventors had labored for many years, a success. The helicopter interests had been trying since the latter part of the nineteenth century. The problems had been many, but the two outstanding obstacles were power for flight and control in flight. With the arrival of the gasoline engine, the problem of power dissolved. Adequate control for such a machine that was intended to lift straight up and come straight down and fly with a great range of speed was not so easily solved. By the early thirties, the Autogiro had a control system that used the rotating blades for control for vertical flight and for low speed flight.**

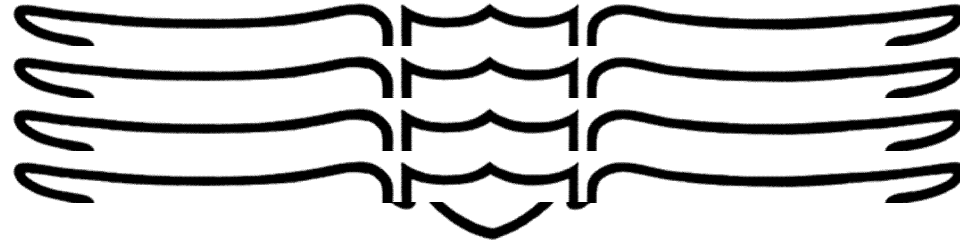

***“By 1931, the N.A.C.A had begun to study the autogiro extensively, but the innovations that occurred in the technology, such as direct control and jump takeoff, happened at the hands of the industry, not government researchers, who instead concentrated on developing an understanding of fundamental principles of rotary-wing flight. However, the N.A.C.A. did succeed in establishing a significant body of knowledge on rotor design that the industry would not have been able to compile itself. The publications that resulted from this effort meant that the helicopter pioneers of the 1940s did not have to retrace their steps in the field of rotor design and could concentrate on the fundamental issues of control and stability.”***

***Roger Connor, 2006***

***Above: National Advisory Committee for Aeronautics (N.A.C.A) logo. The N.A.C.A. was the forerunner of N.A.S.A.*** 265



***“I am firmly convinced that the autogiro solution marks only a provisional stage in the evolution of rotary-wing aircraft, and that the pure helicopter will hold the sky in the future...the helicopter will have a flexibility of use which will be superior to that of any other flying machine, permitting on one hand, hovering and vertical flight, and on the other hand, propulsion at a very high speed under particularly economical conditions...No matter how efficient an autogiro may be, the loss of power due to its separate propulsive propeller will remain great. On the contrary, I have proved that the propulsive efficiency of a helicopter – of a gyroplane – always remains practically constant and equal...and does not vary far from the optimum value, especially of the range of forward inclination of the axis does not exceed six or seven degrees.”***

***Louis Brequet, 1938***

**Left: French aviation pioneer Louis Brequet**



During the period 1930--1936, French aviation pioneers *Louis Breguet* and *Rene Dorand* made particularly notable advances in the development of a practical helicopter. Their machine of 1935 was relatively large for the era, with a coaxial rotor configuration. Each rotor had two tapered blades that were mounted to the hub with flap and lag hinges. The blades were controlled in cyclic pitch using a "swashplate" design. Yaw control was achieved by differential torque on one rotor with respect to the other rotor. Horizontal and vertical tails were used for increased stability. For its time, the aircraft held several records, including a duration flight of 62 minutes and distance flown of 44 km (27 miles). Further work on the Breguet-Dorand machine (left) concluded prior to the outbreak of WWII.

**By the late 1930s, war clouds were gathering and the U.S. Military released a request for bids from aircraft manufacturers to design and build a practical helicopter. Contracts were given to *Sikorsky Aircraft* in *Bridgeport, Connecticut* and *Platt-LePage* in the *Philadelphia* area. By 1940, Sikorsky had a helicopter that could fly, but the control system was so complicated that it was an impractical helicopter to bring to market.**

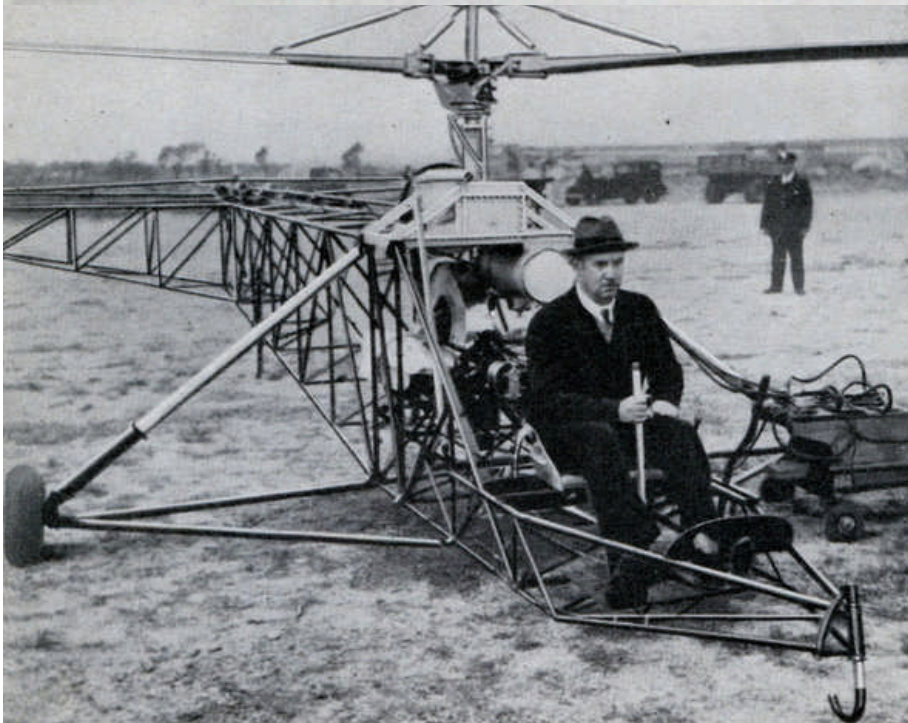
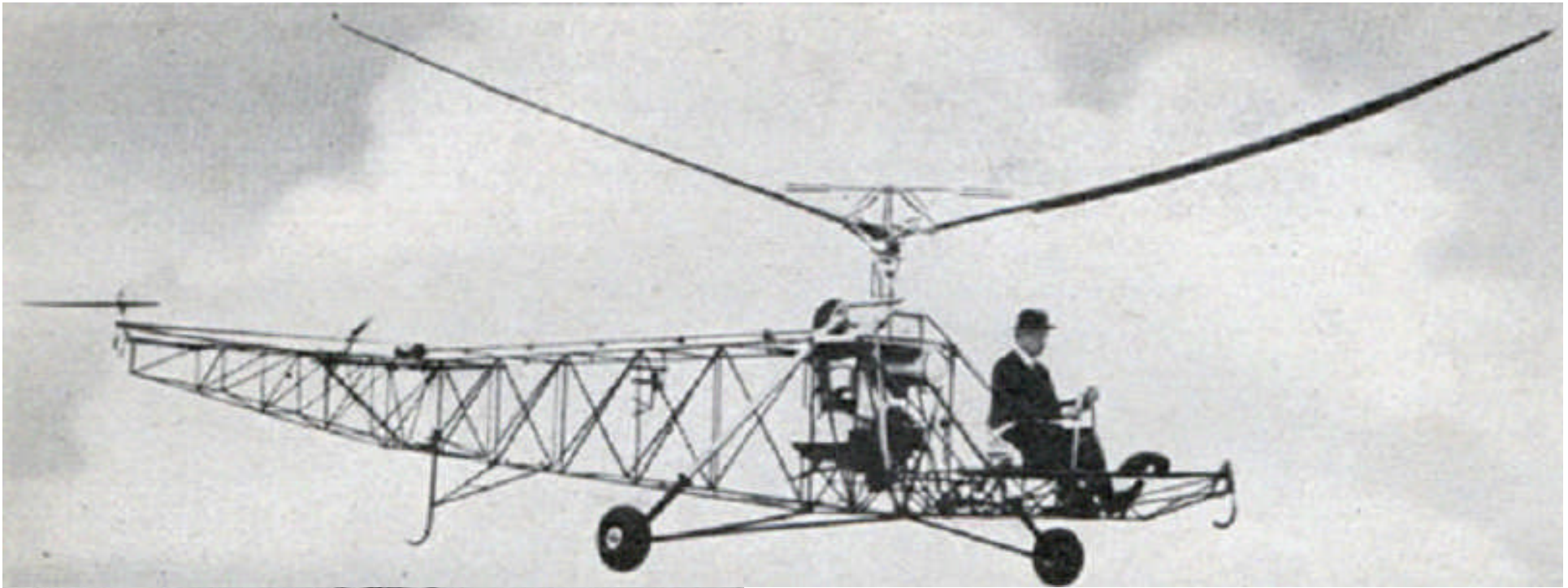

***“What is claimed to be the first successfully controlled vertical flight in a heavier-than-air machine was made recently by Igor Sikorsky, prominent aeronautical engineer, at Bridgeport, Conn., in his new helicopter. Powered by a seventy-horsepower engine and equipped with variable-pitch rotor blades, the craft moved straight up from the ground for thirty feet, circled the field, and then settled vertically to the ground. Small rotor blades mounted on the bare fuselage of the craft act as elevators and rudder. Sikorsky is shown at the controls of the helicopter in the photographs.”***

***Popular Science, September 1940***

***Left: caption: “Igor Sikorsky about to take off on a test flight in his helicopter”***

***Above: caption: “The odd machine in the air”***

**Colonel *Frank Gregory*, who was in charge of rotary wing design and procurement for the *U.S. Army Air Corps*, urged Sikorsky to enter into an agreement with the *Autogiro Company of America* as a licensee and thus have the use of all of ACA's patents and designs. Sikorsky followed this advice and with the Autogiro rotor system added, had a very successful and relatively simple helicopter. Sikorsky began delivering helicopters to the U.S. Military in the early forties and with these deliveries, Autogiro activity effectively ceased. Without the pioneering work of the licensees of Juan de la Cierva's principals in *Europe* in the *United States*, the success of the helicopter would not have occurred with such rapidity.**



**Left: the *Sikorsky R-4* was a two-place helicopter designed by *Igor Sikorsky* with a single, three-bladed main rotor and powered by a radial engine. The R-4 was the world's first large-scale mass-produced helicopter and the first helicopter to enter service with the *United States Army Air Corps, Navy and Coast Guard*, as well as the United Kingdom's *Royal Air Force and Royal Navy*.**

**Right: in 1941, *Igor Sikorsky* fitted utility floats (a.k.a. "pontoons") to the *Vought-Sikorsky VS-300*, making it the first practical amphibious helicopter. The water-landing feature soon proved its worth. Non-amphibious helicopters were required to hover above the scene of a water accident and utilize a hoist. but amphibious helicopters were capable of setting down on the water to effect a rescue directly.**





# Part 4

# The Spaniard

# **The Principle He Brought Forth**

***“...To reach a correct understanding of the Autogiro and its principles which underlie its performance, I feel that it will first be necessary to tell something of the man who has invented the most remarkable aircraft known up to this time. Senor Juan de la Cierva is a Spanish gentleman of great personal charm and brilliance. In his own land he is a person of real consequence. On the technical side, his genius undoubtedly places him among the world’s foremost mathematicians. His democratic manner, kindness, and tirelessness in his work have brought him the respect of all with whom he has come into contact, and although he has received some of the highest of the world’s honors, he is among the plainest of men in his ways. He is a tremendous worker; the present degree of perfection to which he has attained in the Autogiro is due, almost in entirety, to his efforts alone. He had faith in the principle which he first brought forth, and in the face of many disappointments, due to machines which refused to leave the ground, he persevered in his efforts until the Autogiro has finally proven practical and safe...”***

***Harold F. Pitcairn – President, Pitcairn-Cierva Autogiro Company of America***

***RE: excerpt from a speech he made at the Franklin Institute in Philadelphia in November 1929***



***Juan de la Cierva*** was born on September 21<sup>st</sup> 1895 in *Murcia, Spain*, into a wealthy family, as a teenager he experimented with gliders. His experiments with aircraft began as early as 1912. The fledgling aviator attended the *Escuela Especial de Ingenieros de Caminos, Canales y Puertos* in *Madrid* for six years, earning his degree in civil engineering. Cierva, with his education complete, entered a competition to design an aircraft for the Spanish military. His design entry was a bi-wing bomber that was tested in May of 1919. Unfortunately, the pilot stalled the aircraft and it crashed.

# **Something Distinctly Different**

***“The most extraordinary figure that has loomed on the aeronautical horizon since the days of the Wright brothers is Senor de la Cierva, inventor of the Autogiro. This fact must be admitted regardless of any predilections for or aversions toward the autogiro itself. The name of its inventor is destined to go down in history, if not with the Wrights – that would be too much to expect of any name – at any rate as the name of the first man to hit upon a radical innovation in the Wright’s system of securing controlled free flight. That statement may seem extravagant but it will stand examination. Heavier-than-air flying, with the single exception of the autogiro, is today in method exactly what it was as demonstrated by the Wrights a quarter of a century ago. Their work has been developed, refinements have been introduced, power plants have been perfected, but the fundamentals are the same, It remained for Cierva to try something distinctly different – something different, that is to say, that works.”***

***U.S. Air Services, January 1931***



**Cierva created a tri-motor airplane in 1918 and had successfully completed three flights in the ship and then it too crashed in 1919. Rather than let this these unfortunate turn of events deter him, he began a search to design an aircraft that would be independent of the stall characteristics found with fixed-wing aircraft. Following serious investigation into overcoming the stall issues on airplanes, Cierva started an approach at making the wing move continuously in the relative airstream.**



# **The Theory of the Autogiro**

***“An Autogiro differs from an airplane in that from 80% to 100% of the entire weight of the machine is carried by a rotating rather than a fixed wing system. All heavier-than-air machines obtain their lift through dynamic means, that is, a downward momentum, equal to the weight of the machine, must be imparted to a volume of air. Due to the low density of air, a large volume per unit time must be given downward momentum in order that a machine may maintain level flight. This requires a considerable velocity of the lifting surfaces with respect to the surrounding air. In a fixed wing machine, this is obtained by driving the machine as a whole through the air at the required speed, while in an Autogiro, the required velocity of the lifting surface is obtained by a practically constant rotational speed of the rotating wings or rotor independent of the forward speed of the remainder of the machine. Because the rotor system and its operation is practically independent of forward speed, and as the individual elements of the rotor blades operate at relatively low incidence, the Autogiro will neither stall nor spin, and has low speed characteristics superior to a fixed wing machine. The rotor operates in flight without driving means from the engine of the machine, air forces alone keeping it operative. Before the air forces which keep the rotor turning in flight can be fully operative, the rotor must be brought up to a certain minimum rotational speed...”***

**RE: excerpt from *The Theory of the Autogiro***

# Autorotation

***“...constants used by Lielienthal show the arched surface (of an airfoil) still possess supporting powers when the angle of incidence becomes negative, i.e. below the horizontal. The air pressure becomes a propelling force at angles exceeding three degrees up to thirty degrees...by this construction, the air was thrust upward on the outer surface while the air rushed in to fill the partial vacuum thus formed, exerting a powerful lift at the same time was pushed forward, thus tending to diminish head resistance...at certain angles, the total air pressure acting on the plane (wing) cease to act in a line normal to the plane (wing) or its chord, instead, the line of action of this force takes a position well in front. The pressure thus materially acting in the dual role of supporting and propelling force...”***

**RE: excerpt from *Practical Aeronautics* (1912). Autorotation was not invented by the helicopter engineers as a way to lower their crafts safely to the ground when their power-plant failed nor was it invented by *Juan de la Cierva*. The force that makes autorotation possible was known to aeronautical inventors at least as far back as 1909. In fact, nature has produced countless tiny autorotating seed pods that deliver their seeds to earth each autumn.**



***“...European maples and sycamores have an even more economical design. They are equipped with only a single wing, sprouting from one side. The balance between the weight of the seed and the length of the wing is so accurately matched that these seeds also spin...Even in a light breeze their tiny spinning helicopters can travel for very long distances across the countryside...”***

***David Attenborough, Author***

***Above: Sycamore Maple seed pod***

**An Autogiro (like a helicopter) is a rotary wing aircraft which means that it has a rotor to provide lift instead of fixed wings as do conventional airplanes. However, unlike a helicopter, the rotor is not powered by the engine. It is made to spin in flight by aerodynamic forces alone through the phenomenon of *autorotation*. What causes the rotor to spin, or autorotate, is the wind passing through it thus giving it its power. Consider a seed pod that spins as it falls. As it falls, passing air makes it spin creating lift so the seed pod doesn't fall as fast as it would otherwise (if it didn't spin).**

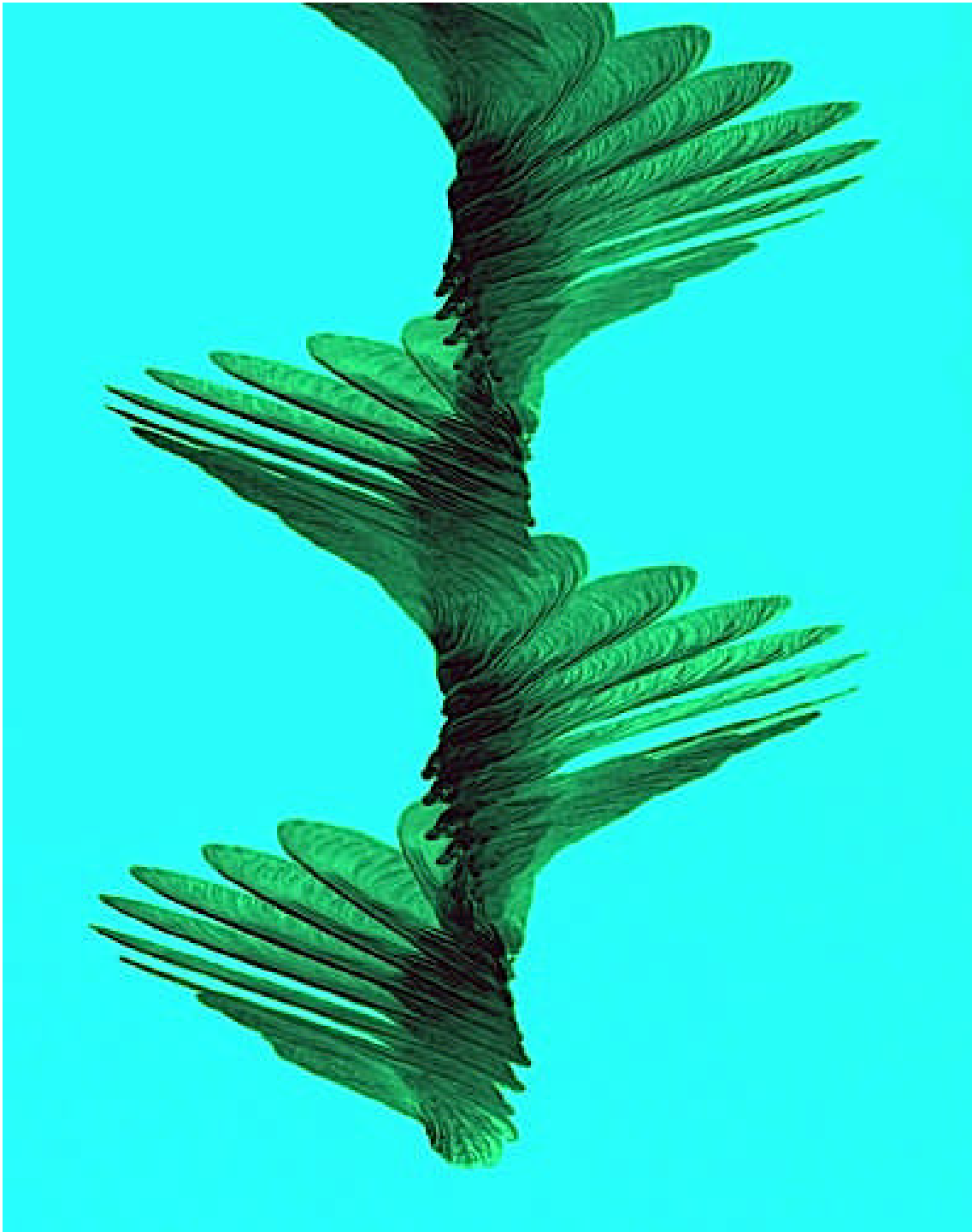

**Left: high-speed photograph revealing how a maple seed pod falls via autorotation. The flat, elongated pods are densest at their seed-containing ends, a configuration that causes them to autorotate while falling. Rotation creates small vortexes above their leading edges. By pulling in air, a vortex lowers the air pressure above a pod's surface, giving it lift.**

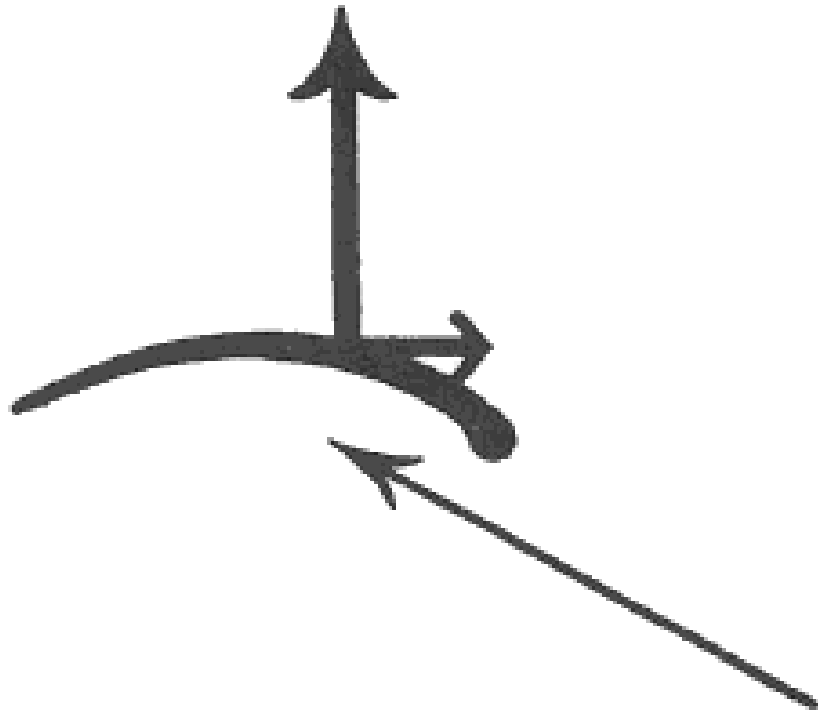
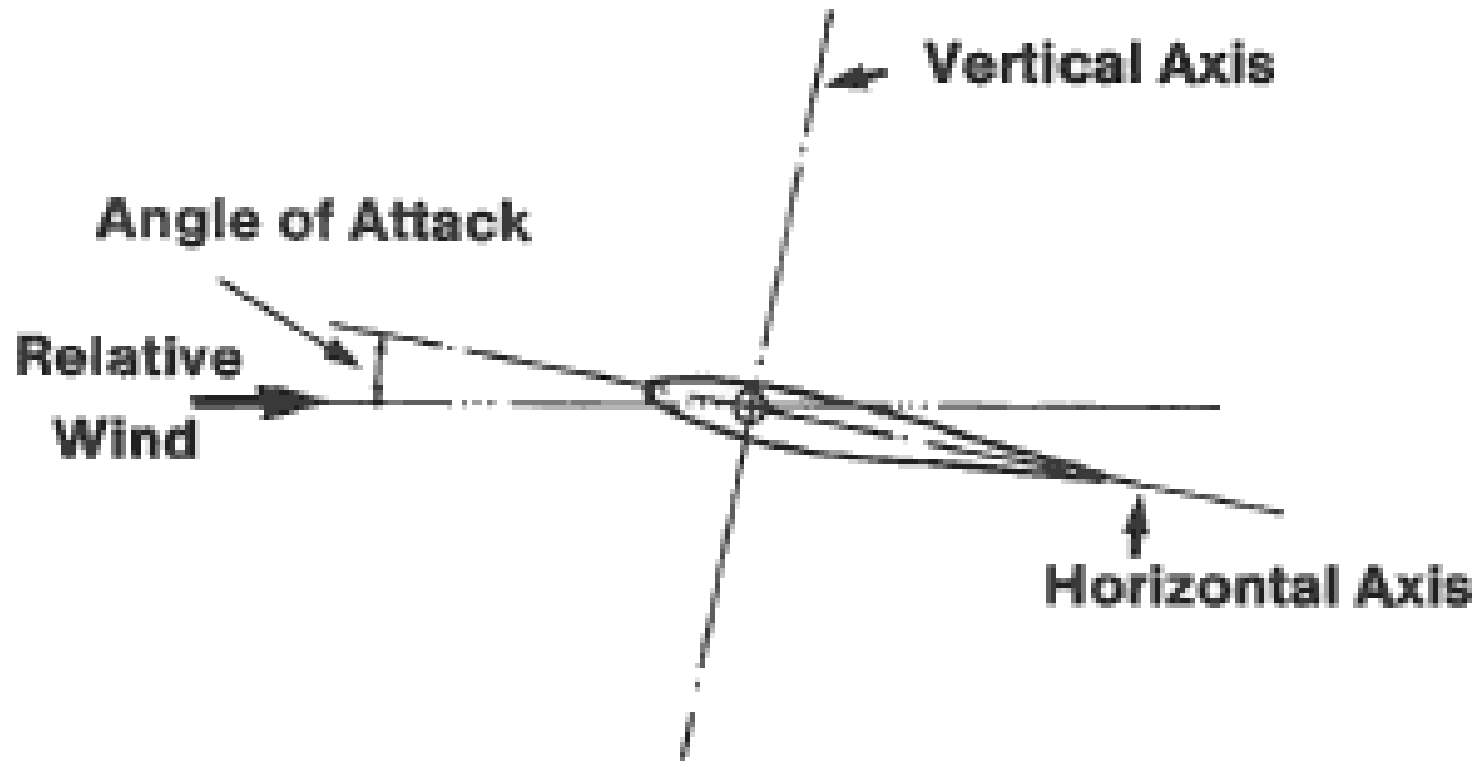

Fig. 1

***“...Thus we have a bird weighing 4.25 pounds, not only thoroughly supported, but propelled forward by a force of 0.359 pounds at 17 miles per hour...”***

**RE: excerpt from *Practical Aeronautics* (1912). A “Force Diagram for a Soaring Plane” (Fig. 1, at left - from *Practical Aeronautics*) shows the action of an airfoil in flight showing one inventor’s understanding of the forces: one vertical arrow, showing “lift” and another arrow pointing forward to illustrate the propelling force.**



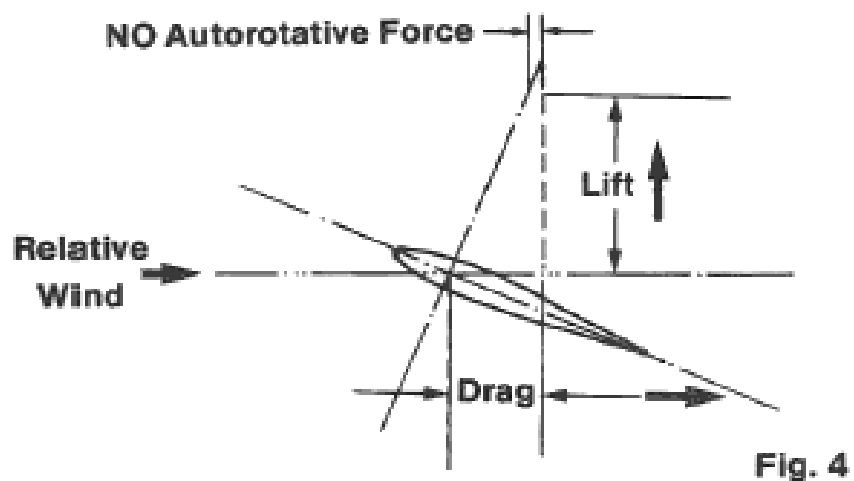
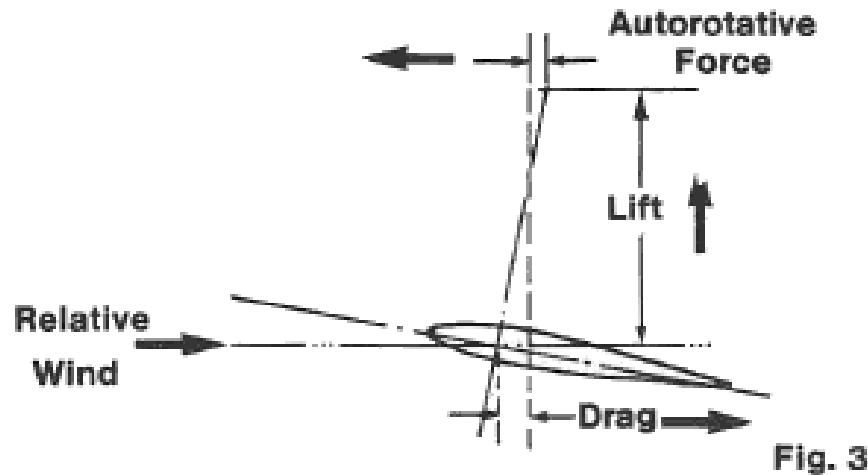

**Fig. 2**

**Figure 2 (above) shows the “Rules” for lift;**

- 1. Lift acts at 90 degrees from the relative wind**
- 2. Drag acts parallel to the relative wind**

**With knowledge of this forward propelling phenomena it's easy to see that Cierva would decide to anchor one end of his airfoil/s and when they were propelled forward, they would rotate.**



In Figure 3 (left), it's assumed that the values of lift and drag (measured in pounds) are drawn to the same scale. It can be seen that the "lift" line crosses the vertical axis of the airfoil. The value of the lift line ahead of the axis is a propulsive force. In figure 4 (right), the angle of attack of the airfoil is increased which increases the drag. Lift is increased also, but not at the same rate as the drag. In this figure you will see that the "lift" line does not cross the vertical axis and no autorotative force is produced. In an actual situation, very soon after the rotor was put in this angle of attack and if no power was being applied to the rotor, the rotation would stop.

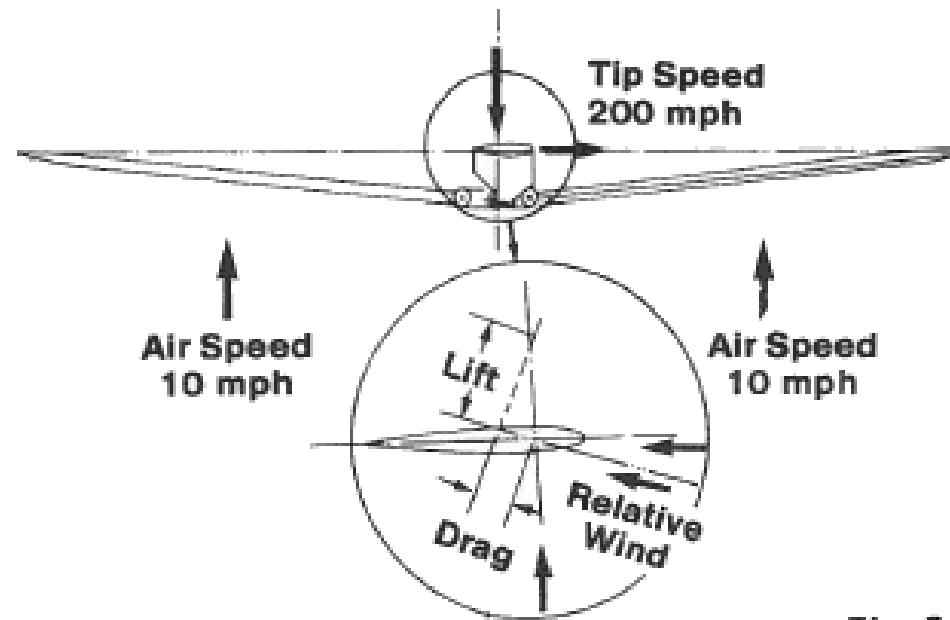
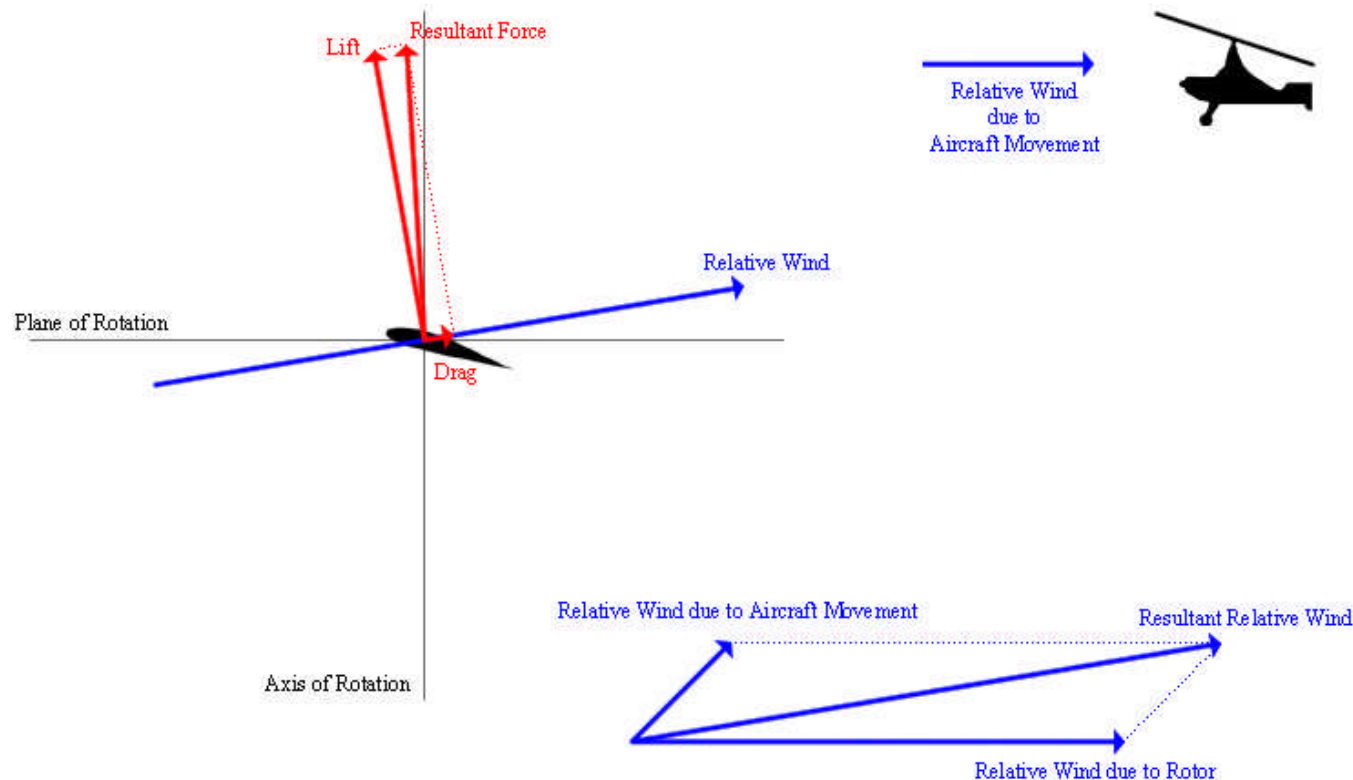
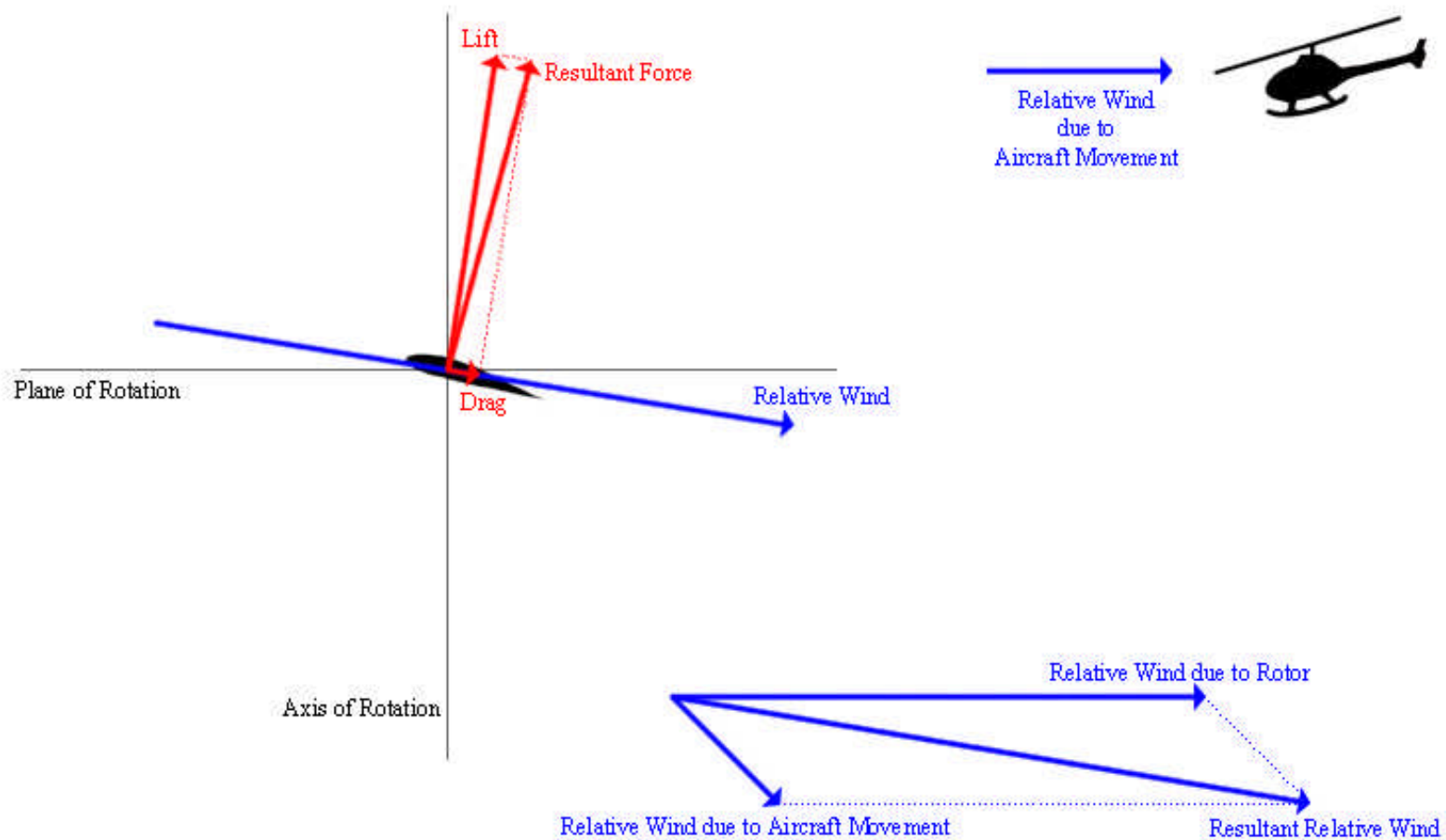

Fig. 5

As long as an Autogiro was in level flight, the angle of attack remained within the limits for producing an autorotative force. However, the layman found it difficult to understand how the angle of attack of the rotor blades could be kept at a low value when the Autogiro was descending vertically (when the air is flowing straight up at the rotor). Figure 5 (above) shows that while the Autogiro and the rotor system are descending vertically (usually at about 10 mph) the rotor tip speed is about 200 mph. Because it is in vertical descent, the air speed at the tip in any point around the circumference of the rotor is the same and there is no “advancing” blade (which meets a greater air speed for part of its circumference) or a “retreating” blade (which meets a wind blowing towards its trailing edge) because it is not in forward flight. It can be seen from figure 5 that a resolution of all the winds will show a resulting wind from a low enough angle to permit autorotation to continue.



The vector diagram above illustrates *autorotation*. The diagram in the lower right shows the winds relative to the rotor. Since the rotor is spinning, there will be relative wind due to this spin, which is labeled as “Relative Wind due to Rotor.” The “Relative Wind due to Aircraft Movement” is due to the fact that the aircraft is moving forward, and the rotor is mounted in such a way that the plane of rotation is at a slight angle to the direction the aircraft is moving in. The sum of these two vectors is the relative wind to the airfoil and is labeled as “Resultant Relative Wind.” The main diagram shows a cross section of the rotor at a point in time where it is moving forward relative to the aircraft. The *Resultant Relative Wind* from the smaller diagram is shown on this as “Relative Wind.” Any wind passing over an airfoil will create both lift and drag. The lift will be perpendicular to the airflow, and the drag will be parallel to the airflow. This is true for all airfoils, not just for the rotor in an Autogiro. When the lift and drag vectors are added together, they create a “Resultant Force.” In autorotation, this resultant force is in front of the Axis of Rotation, so in addition to providing lift, it also pulls the rotor forward. This is in sharp contrast to the rotor of a helicopter in forward flight.



A helicopter gets its propulsion by tilting the rotor forward. This angles the lift forward, giving the helicopter forward propulsion. However, this makes the *Relative Wind* due to the aircraft movement move down over the rotor instead of up through it as in an Autogiro. The vector diagram above (which is the exact format as for an Autogiro and uses the same labels) shows the results of this different relative airflow. Instead of pulling the rotor forward, it actually holds the rotor back.

**There are several advantages that Autogiros have over helicopters, namely;**

- Simplicity;**
- Speed, and;**
- Weight**

**A helicopter rotor must be complex to a certain degree. It provides the lift, thrust and control for the aircraft. It needs a method for cyclic and pitch control. An Autogiro also uses the rotor for control, but it does not need collective control. Some of the more complex Autogiros had collective control, but it was not a necessity for the smaller Autogiros. This reduces the complexity of the system and, by eliminating controls, reduces weight. The weight in an Autogiro is also reduced because it does not power the rotor in flight. To power the rotor in flight typically requires that it be connected to the engine through drive shafts and gearboxes. These must be strong enough to handle the torque driving the rotor and add up to a significant weight. An Autogiro does not need these systems thus it could be made lighter. Even if an Autogiro has these systems for pre-rotating the rotor for a jump take-off, they did not need to be as robust as those in a helicopter because they did not need to handle the same amount of torque. Also, because they are not flight critical, they need not be over-designed. An Autogiro can also fly faster than a helicopter. This is due to the fact that the rotor is providing only lift, whereas the rotor in a helicopter is providing both lift and thrust. For a rotorcraft to stay balanced, it must produce the same lift on both the advancing and retreating blades. The advancing blade (the one moving with the aircraft) has a higher velocity than the retreating blade. So, to produce the same amount of lift, the retreating blade must be at a higher angle of attack. At a certain angle of attack, the blade will stall, and will quit providing lift. This is a limiting factor in both Autogiros and helicopters. But because the helicopter must generate more force with its rotor, it will encounter this problem at a lower speed than an Autogiro, allowing the Autogiro to fly faster.**

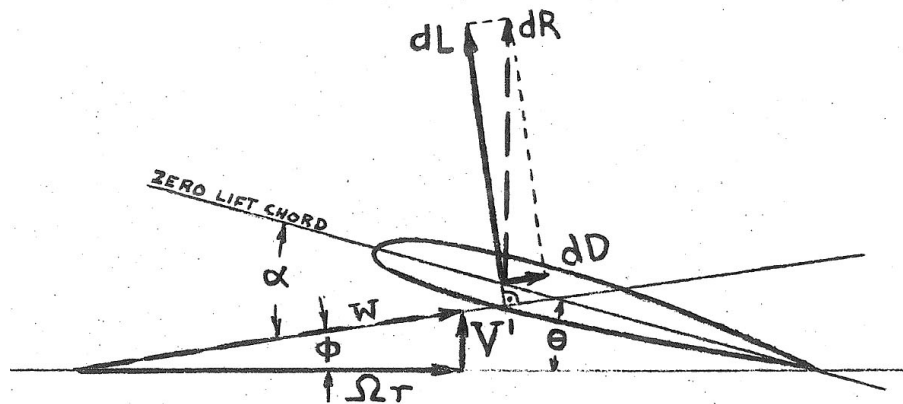

**Above: Generic vector diagram of forces on blade section, whereby;**

**dL → incremental lift force**

**dD → incremental drag force**

**dR → incremental resultant force**

**$\Omega T$  → velocity due to rotor spinning**

**$V'$  → velocity of aircraft**

**$w$  → resultant velocity at element**

**$\theta$  → angle of blade relative to plane of rotation (collective)**

**$\Phi$  → change in angle due to aircraft velocity**

**$\alpha$  → angle of attack**

The other part of an Autogiro's advantage flying at low speed is its inability to stall. As an airplane flies slower, it must increase the angle at which it is flying to create more lift. At a certain point, this angle becomes too great, the air stops flowing over the wings smoothly and the wing stalls. When this happens, the airplane falls, just like dropping a baseball out a window. When an Autogiro slows to a speed less than that needed to maintain autorotation, lift is not instantly lost. Instead, the rotor just starts slowing down. Since it's still spinning, it's still creating lift. The result of slowing an Autogiro down too much is just that the aircraft will descend gently. It will not fall like an airplane does. But these advantages aren't without drawbacks. Even though the rotors create less drag than the large wings of low-speed airplanes, they create more drag than the smaller wings of higher speed airplanes. Thus, Autogiros create more drag than airplanes of comparable size that fly at the same speeds. Also, because of this drag, Autogiros are not suitable for high-speed flight or long-distance flight. 294

***“The flow over the inner halves of the rotor blades on a Kellet YG-1B autogiro was investigated in flight by making camera records of the motion of silk streamers attached to the upper surfaces of the blades. These records were analyzed to determine the boundaries of the region within which the flow over the blade sections was stalled for various tip-speed ratios...The theoretical analysis of the autogiro rotor...includes expressions from which the angle of attack of a blade element at any position in the rotor disk can be calculated. These expressions indicate the existence of three distinct regions on the rotor disk. In one of these regions, the blade elements are unstalled; in another, they are stalled; and, in the third, they are subjected to a reverse flow, with the air moving from trailing edge to leading edge, The boundaries of the stalled region, which lies between the other two regions on the rotor disk, can be calculated from the theoretical expressions, provided that the angle of attack at stall of the blade airfoil section is known...Calculations indicate that the profile drag of stalled blade elements may appreciably lower the maximum lift-drag ratio of a rotor, if the boundaries of the stalled region differ materially from those predicted by theory...The investigation was made at Langley Field during December 1938...”***

**RE: excerpt from *Technical Notes – National Advisory Committee for Aeronautics – Observation in Flight of the Region of Stalled Flow* (December 1939)**





**Above: caption: "N.A.C.A.'s experimental Kellett YG-1B Autogiro at Langley Field"**

**There is one other major advantage that Autogiros have over airplanes and/or helicopters: safety in event of an engine failure. If an engine fails in an Autogiro, the same thing would happen as if the pilot tried to fly too slow. The aircraft would slowly descend until landing. In fact, the procedure for landing an Autogiro after engine failure is the same for landing an Autogiro under ordinary circumstances. In an airplane, when the engine fails, the pilot must try to glide the airplane in to a landing. Pilots do train for this, but “dead-stick” landings require skill and an airplane still needs a runway to land. The pilot must search for an area large and smooth enough to land the airplane, close enough to get to before the plane crashes. Helicopters are also difficult to land in case of an engine failure. As indicated in the vector diagram of a helicopter in forward flight, the aerodynamic forces are working to slow down the rotor. As soon as the engine fails and quits providing power to the rotor, the forces will work to slow the rotor down much more rapidly than in an Autogiro. Pilots correct this by putting the helicopter into autorotation, but this also requires skill. Since helicopters are not designed to normally handle autorotative landings, there is a risk of making a mistake and striking the tail during the landing flair. Even worse, there is a flight regime known as the “dead man’s area” whereby if a helicopter is too low and slow, it won't have enough time to establish autorotation and flair for the landing. Thus, if there is an engine failure it will crash.**



**Above & Left: the helicopter has one major advantage over the Autogiro - the ability to hover. Forward movement of an Autogiro is necessary for its autorotation and, therefore, for sustained lift. When the Autogiro stops moving forward, it begins to descend. With a skilled pilot, a helicopter can stay in one spot until it runs out of gas. Hovering is an essential ability for many of the roles that helicopters perform, especially rescues.**

**Cierva's first approach to the problem was to provide a rotational wing and he conducted several experiments with rigidly mounted rotors. Although these early aircraft had many engineering problems yet to be resolved, the basic foundation of his idea was laid and the Autogiro was patented in 1920. He could see that refinements were needed to absorb the flight loads imposed on the rotor blades and, as well, the need to reduce vibration present in the rigid rotors. Most importantly, Cierva realized that the advancing blade was producing more lift than the retreating blade resulting in an aircraft that tended to roll toward the retreating blade side when the aircraft attempted to take-off. This was a major finding in controlling the forces acting upon the rotor and the primary reason other inventors had failed to produce a working version of the helicopter. At the time, Cierva was trying to solve another problem. He was concerned with the bending stresses on the rotor blades as the lift increased on one side of the rotating circle and decreased on the other.<sup>299</sup>**



It was in *Madrid* in 1920 when *Juan de la Cierva* o built his first Autogiro - the *Cierva C.1* (above). For the C.1, Cierva used the fuselage of a *Deperdussin* - a French monoplane of pre-WWI (1913) vintage on which were mounted two contra-rotating four-bladed rotors. The C.1 had a vertical surface above the rotor to give lateral control. This model never flew, since it proved impossible to control <sup>300</sup> (the lift from the two rotors was unbalanced because of mutual interference).

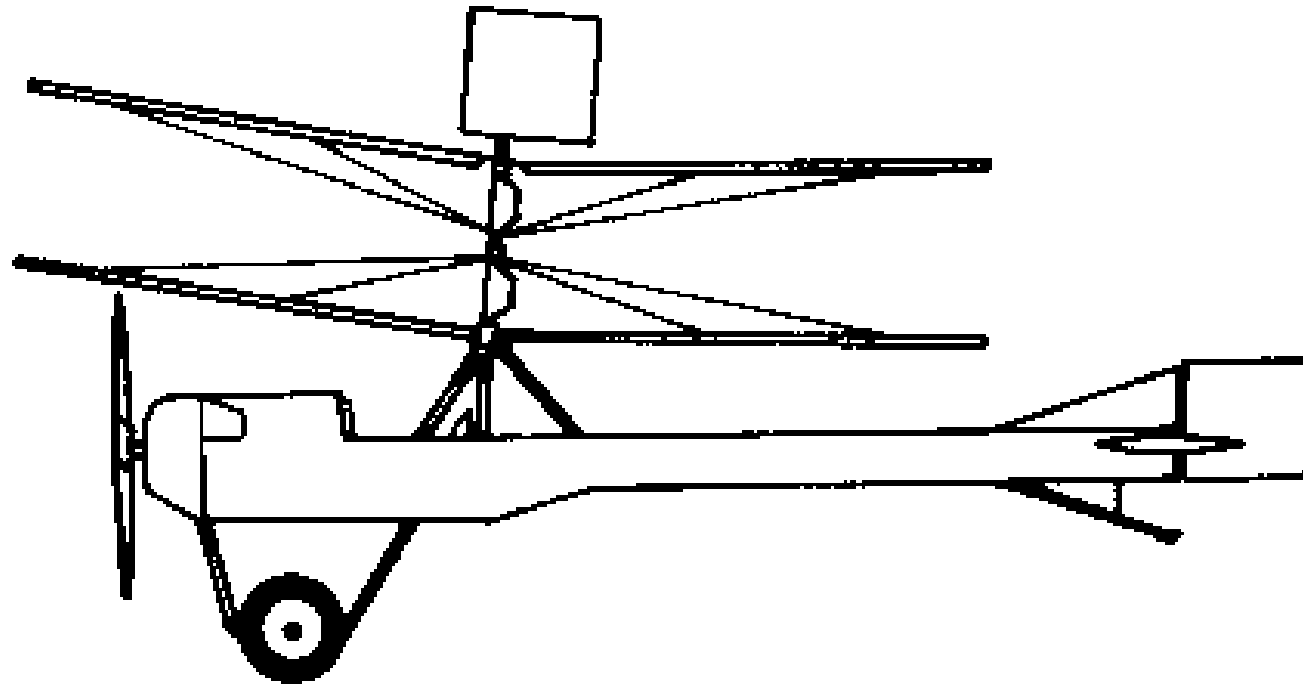
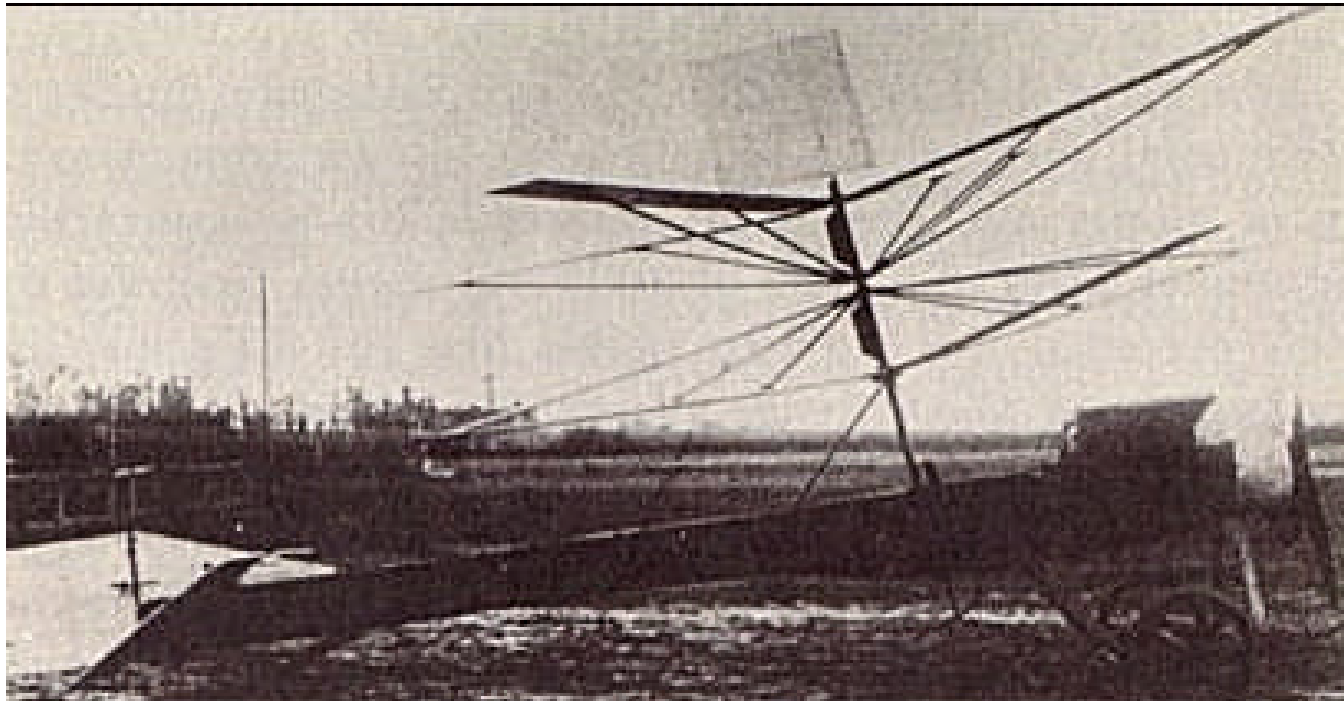

***“My first experiments with this type were encouraging. But after this model had been damaged and reconstructed nine times, it seemed clear that the solution would not be found in such a design.”***

***Juan de la Cierva***

**RE: the prototype Cierva C.2 was completed early in 1921. Above the center of gravity of a bi-plane *Hanriot* fuselage (retaining its elevators and rudder) was fitted a three-bladed rotor, the blades of which incorporated variation of the angle of incidence. C.2 suffered considerable damage and was rebuilt nine times before it was abandoned.**

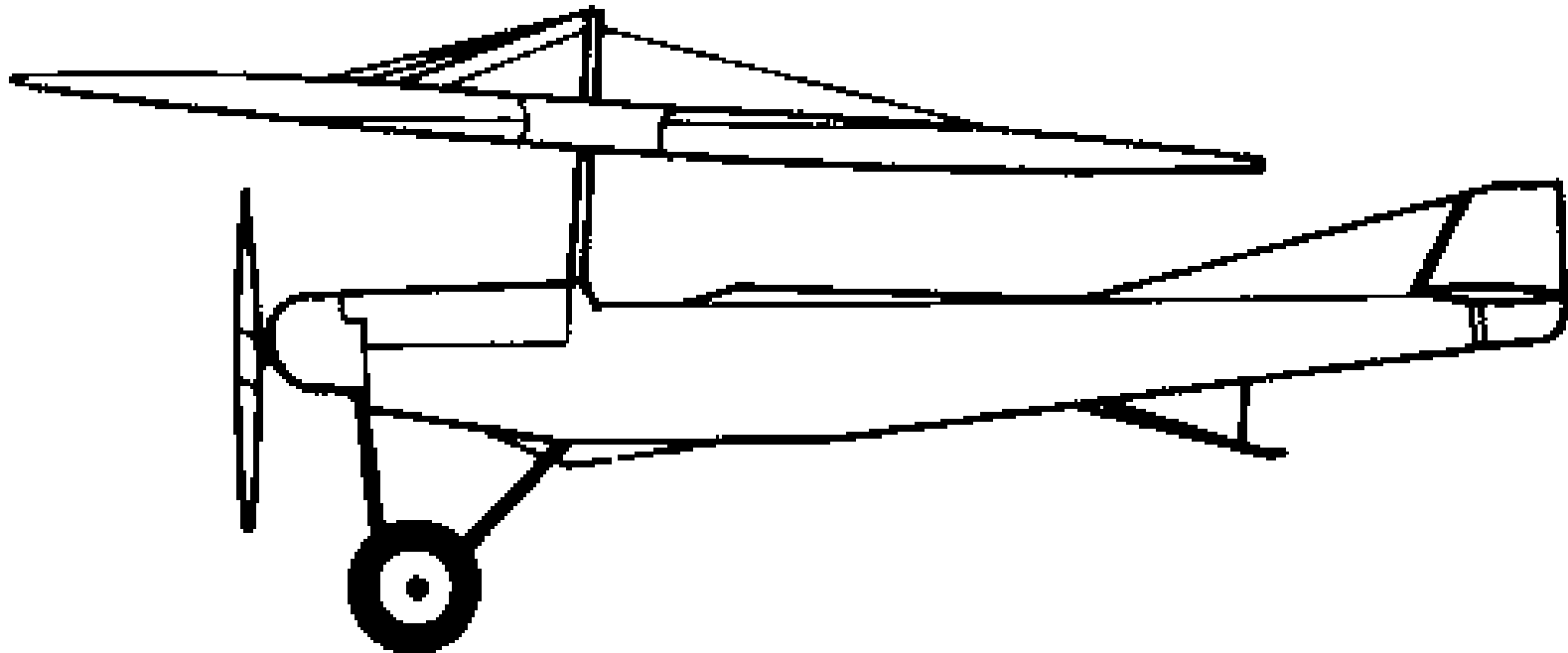
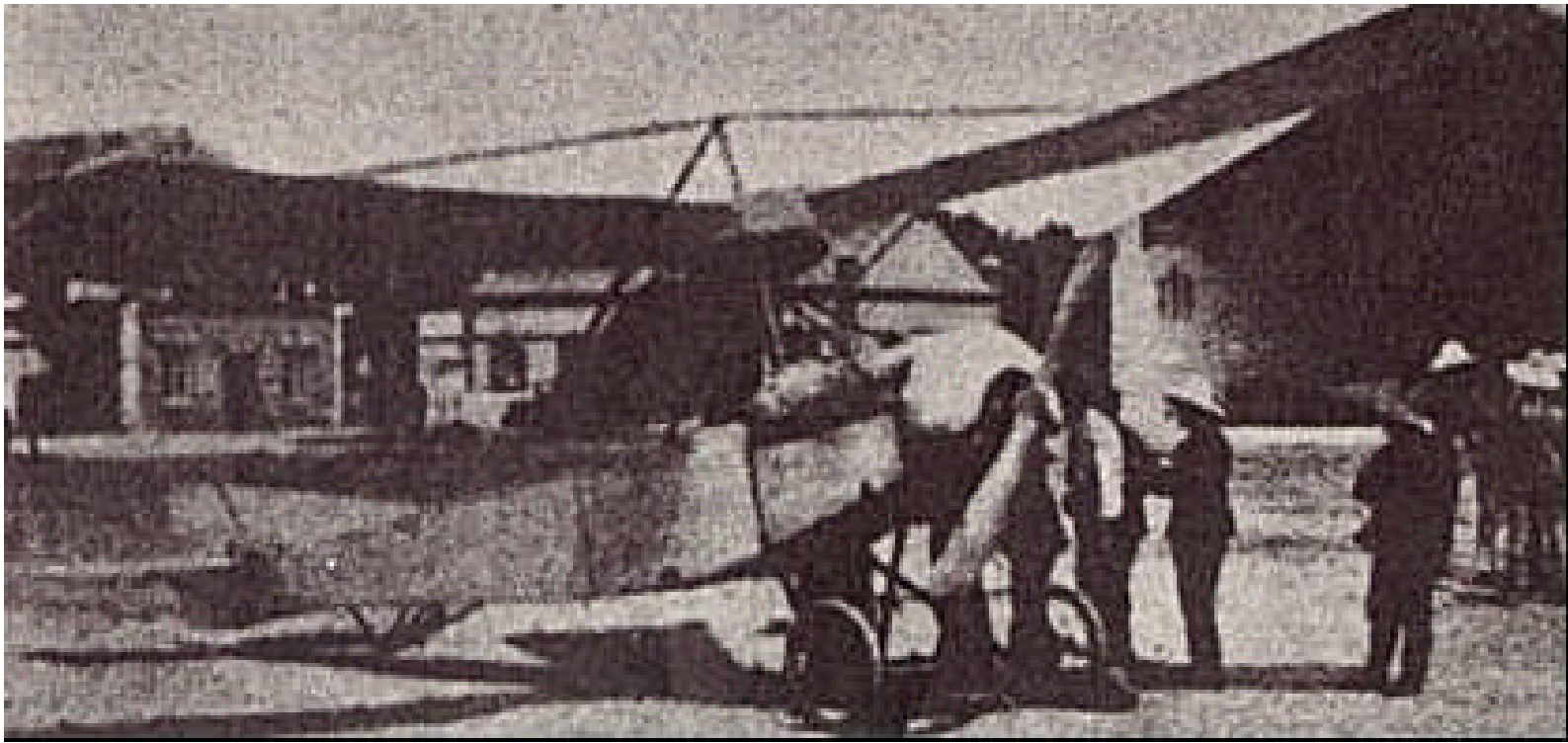



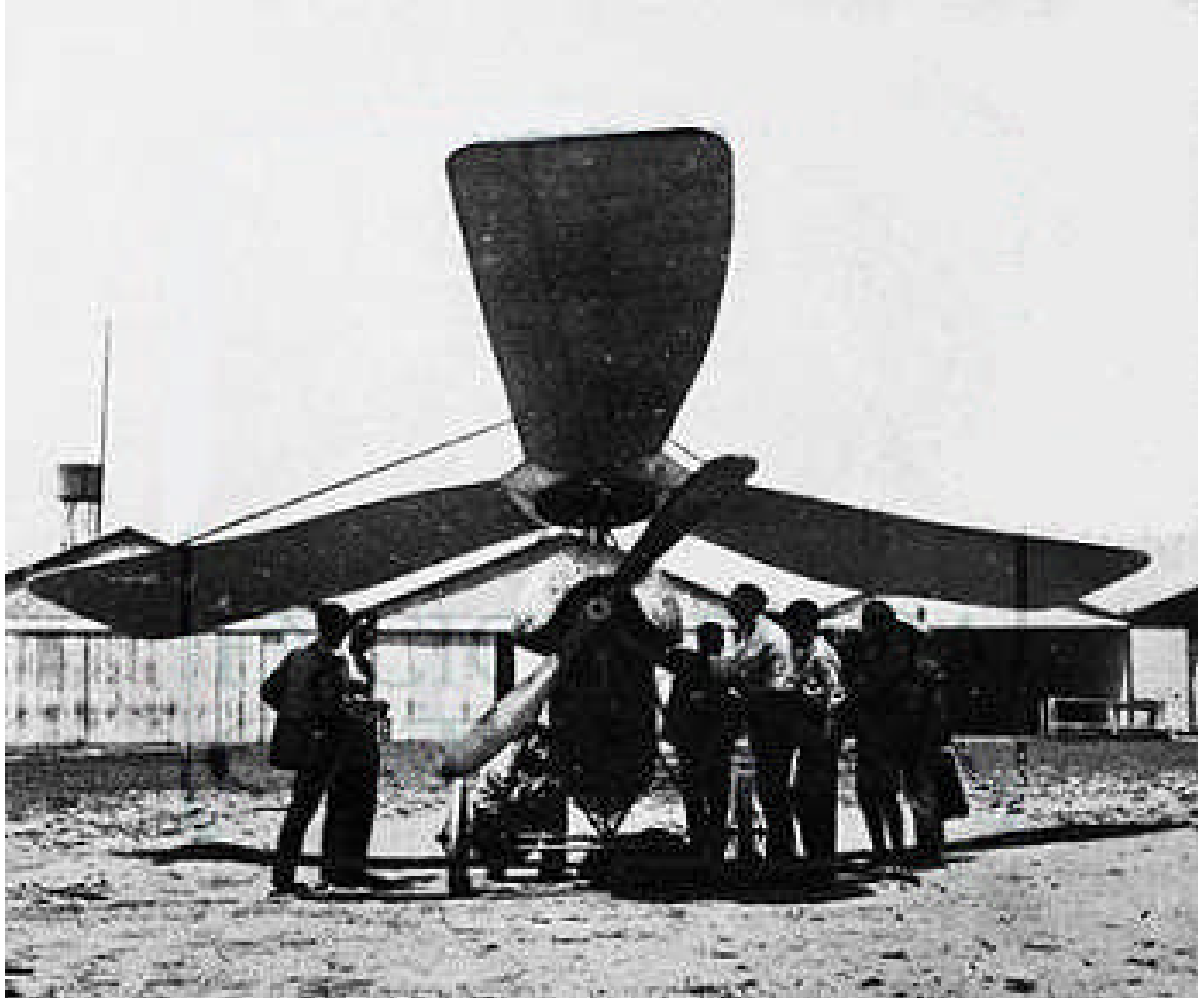

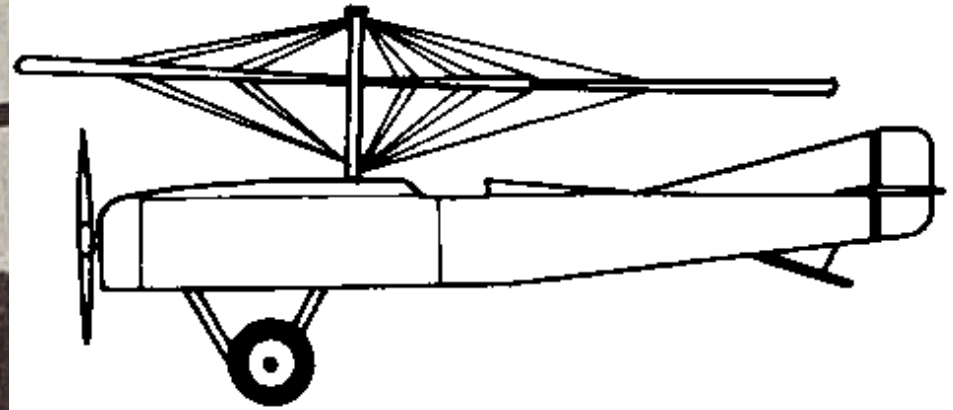
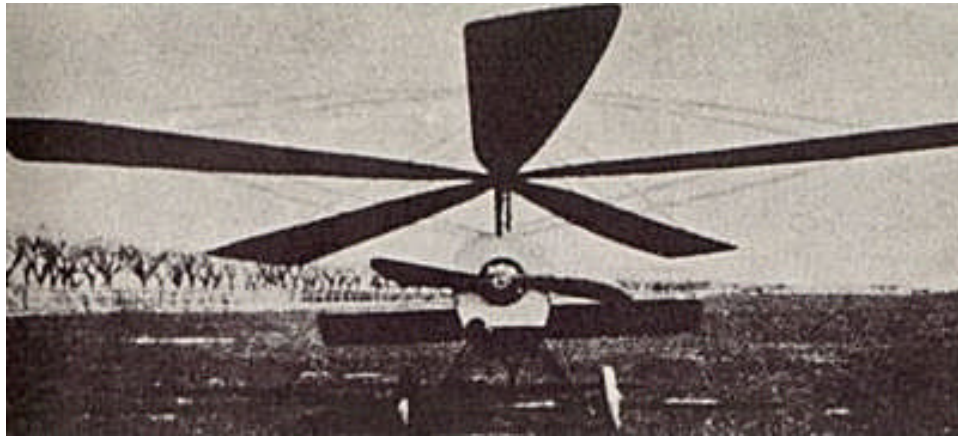

In early 1922, the *Cierva C.3* prototype (above L&R) with five rigid blades was ready for trial. Though its lateral control was improved, it always showed (in Cierva's own words) "a tendency to fall over sideways." It was damaged on several occasions and rebuilt four times. An end was put to Cierva's failures by a toy Autogyro which he had built. Its engine consisted of a twisted rubber band and its rotary wings of flexible palm wood. Unlike the full-sized machines, it flew properly. On comparing it feature-by-feature with the C.3, Cierva discovered that the flexible rotor blades accounted for the toy's successful flight. This gave Cierva the idea of articulating the blades so as to overcome the unbalance between the advancing and retreating blade/s. Once done with the C.3, Cierva went back to the C.2. The C.2 was finally completed early in 1922. It had similar controls to the C.3. It achieved slightly better lateral control, and short hops of a few feet above the ground, but still couldn't maintain sus- 305

tained flight.

# The Knowing

One of the problems with Cierva's three designs (C.1 thru C.3) up to this point was that the rotor was rigid. This created two problems. First, it created a gyroscopic effect. As soon as the aircraft tried to move this effect would cause the aircraft to tilt. The other problem came from unbalanced lift. As the rotor was spinning, one side would be moving the same way the aircraft was moving, increasing the relative wind speed, while the other side would be moving opposite the direction the aircraft was moving, decreasing the relative wind speed. The side with the higher relative wind speed would have a higher lift than the side with lower relative wind speed causing the aircraft to tilt. Cierva came up with a solution to this problem while watching an opera. One of the props for the opera was a windmill with hinged blades. Cierva decided to use hinges in his rotor designs. This allowed the blades to rise and fall depending on what direction they were moving in. The blades moving with the aircraft rose because of the higher lift, but this also served to decrease their angle of attack. The blades traveling in the opposite direction of the Autogiro would fall because of the lower lift, serving to increase their angle of attack. The combination of the rising and falling action, (which came to be known as "flapping") and the increase and decrease this had on the angle of attack served to balance the lift/s created on each side of the aircraft. The hinged blades also eliminated the gyroscopic effect caused by the rigid blades.

**A crash in February 1927 led to an improvement in rotor hub design. A “drag hinge” was incorporated at the hub to allow each blade to drag back a little or pivot forward slightly as it rotated. This relieved the stresses and was another step in developing the fully articulated hub used on many modern helicopters. While other experiments of rotary flight tried to power the rotor blades, Cierva took a more simplified approach in allowing the rotor blades to free-spin or autorotate with thrust being provided by a propeller. To overcome the lifting tendency of the advancing blade (known as “Dissymmetry of Lift”), Cierva decided to hinge the joint at the rotor hub to allow the blades to flap. This would allow the blades to naturally speed up or slow down depending on their position in the rotor disc. He then realized he might have a greater reduction in vibration if he allowed the blades to seek their own lateral position in rotation. Cierva incorporated another set of hinges to allow the blades to lead or lag in their position about the mast. The idea not only worked, it worked very well and Cierva could build his rotor blades from strong yet light weight materials that would be needed to get the performance he sought in his design.**

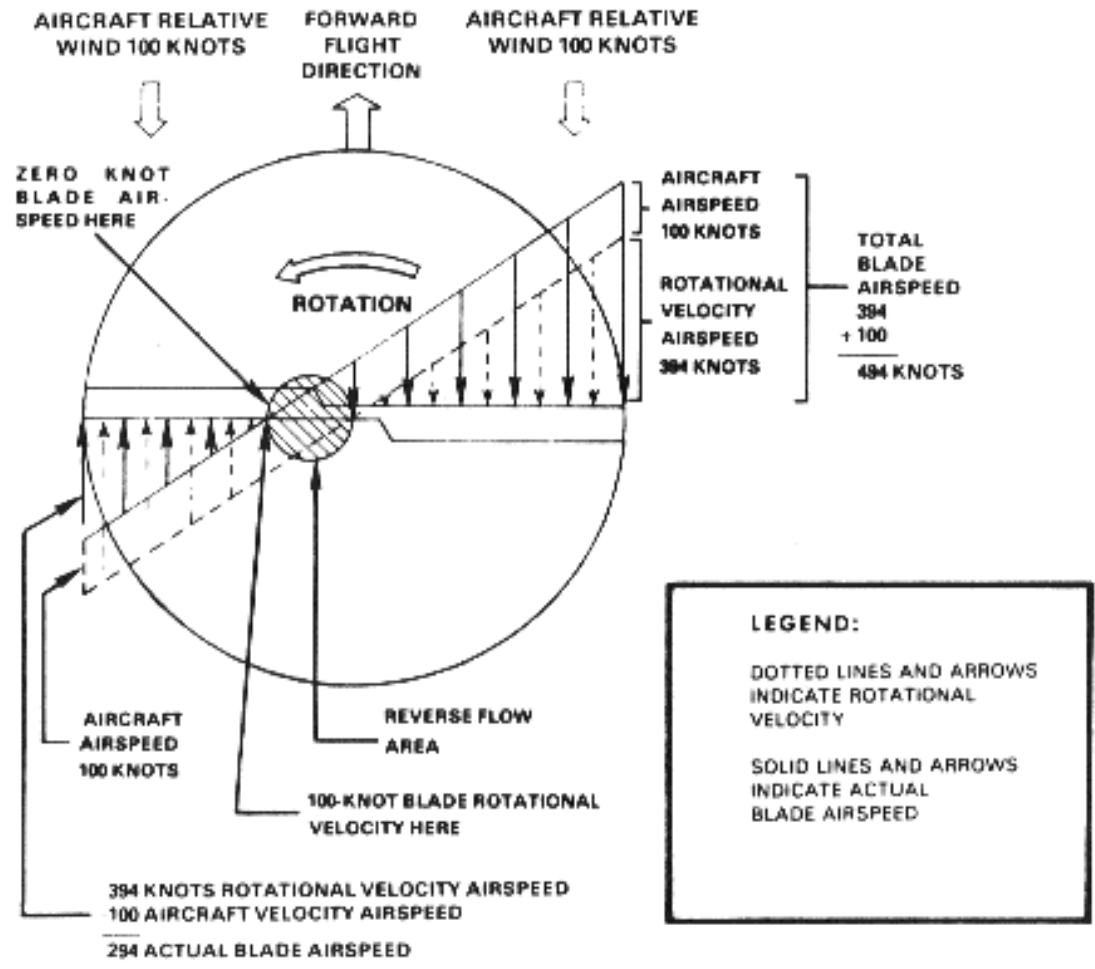

**Above:** caption: “Dissymmetry of lift is the difference in lift that exists between the advancing half of the rotor disk and the retreating half. It is caused by the fact that in directional flight the aircraft relative wind is added to the rotational relative wind on the advancing blade, and subtracted on the retreating blade. The blade passing the tail and advancing around the right side of the rotorcraft has an increasing airspeed which reaches maximum at the three o’clock position. As the blade continues, the airspeed reduces to essentially rotational airspeed over the nose of the rotorcraft. Leaving the nose, the blade airspeed progressively decreases and reaches minimum airspeed at the nine o’clock position. The blade airspeed then increases progressively and again reaches rotational airspeed as it passes over the tail.

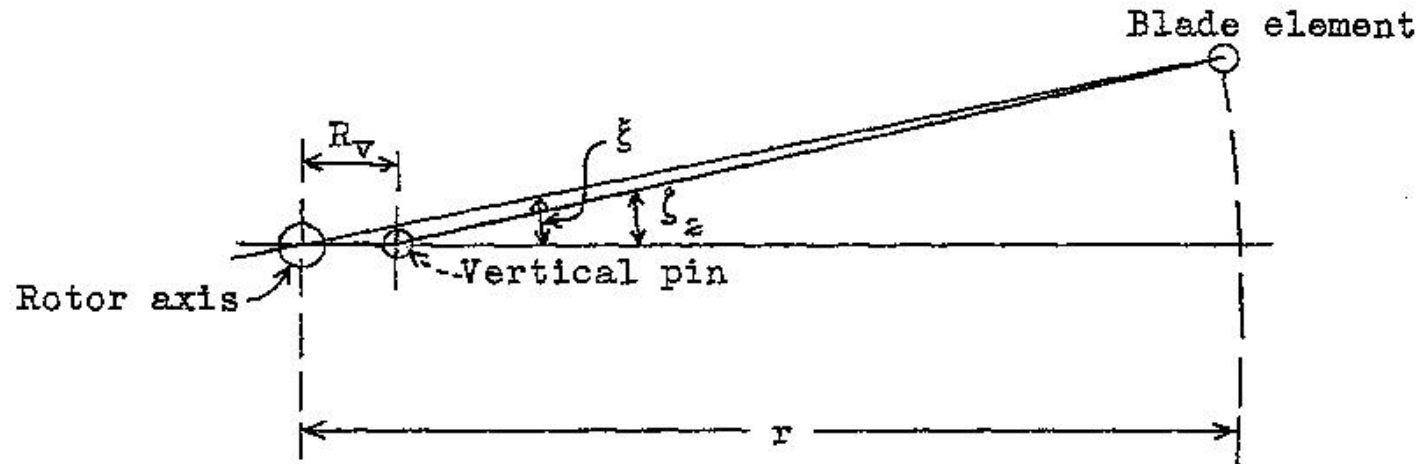

***“...An autogiro rotor blade is connected to the rotor hub in such a way as to permit two articulations, one about the horizontal hinge and one about the vertical hinge. The horizontal hinge axis is perpendicular to the blade span axis and to the rotor axis and permits the blade to oscillate freely in a plane containing the blade span axis and the rotor axis. The vertical hinge axis is parallel to and offset from the rotor axis and permits the blade to oscillate freely in a plane containing the blade span axis and the rotor axis. The vertical hinge axis is parallel to and offset from the rotor axis and permits the blade to oscillate in the plane of rotation. This articulation is required because the forces acting on the blade in the rotor disk are of unsteady nature and experience has shown that heavy stresses and uncomfortable vibrations arise if this articulation is not used. In addition, motion about this hinge is damped by friction so that transient vibrations will quickly subside...”***

**RE: excerpt from *Technical Notes – National Advisory Committee for Aeronautics – A Study of Autogiro Rotor-Blade Oscillations in the Plane of the Rotor Disk* (September 1936)<sup>310</sup>**

**Above: caption: “Figure 1 – Geometry of autogiro rotor blade and vertical-pin articulation”**

## FLAPPING and LEAD/LAG HINGES

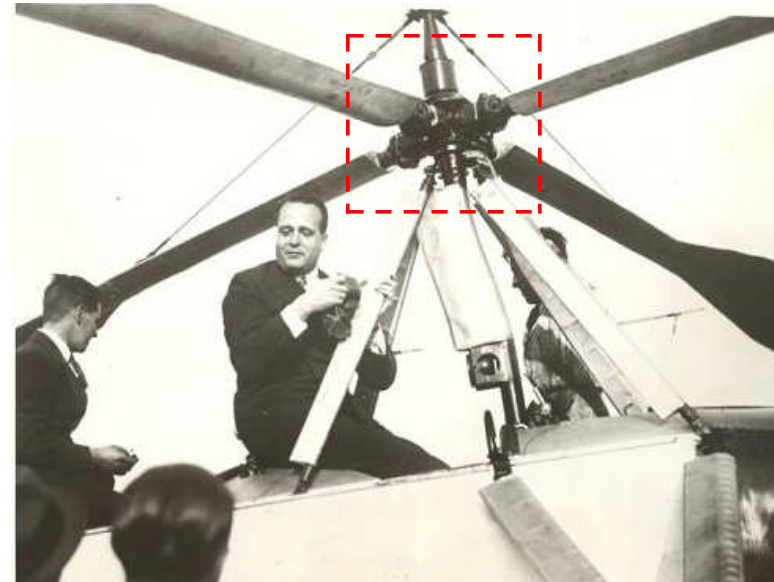
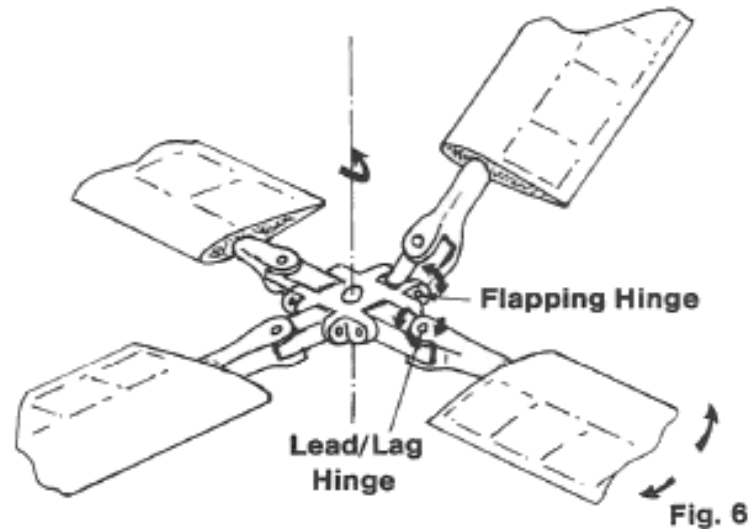

*Juan de la Cierva* never said he “invented something” or that he “discovered something.” Rather, he said, “God permitted him to know something.” Cierva was a structural engineer and had, in the past, designed trusses for bridges that were pinned at the ends to relieve bending. He applied the bridge design principle to the Autogiro rotor blade attachment at the hub. The pin at the hub permitted the blade to “flap” or rise and fall as it rotated (figure 6, left). When the blades were permitted to flap they not only relieved the bending, but allowed the additional lift on the “advancing” blade to cause the blade to rise, rather than roll the Autogiro over. In this case, Cierva said “God permitted him to know two things.” Cierva also put a vertical hinge on the blade to permit it to move fore and aft to relieve the bending as the drag increased on the “advancing” side and decreased on the “retreating” side.



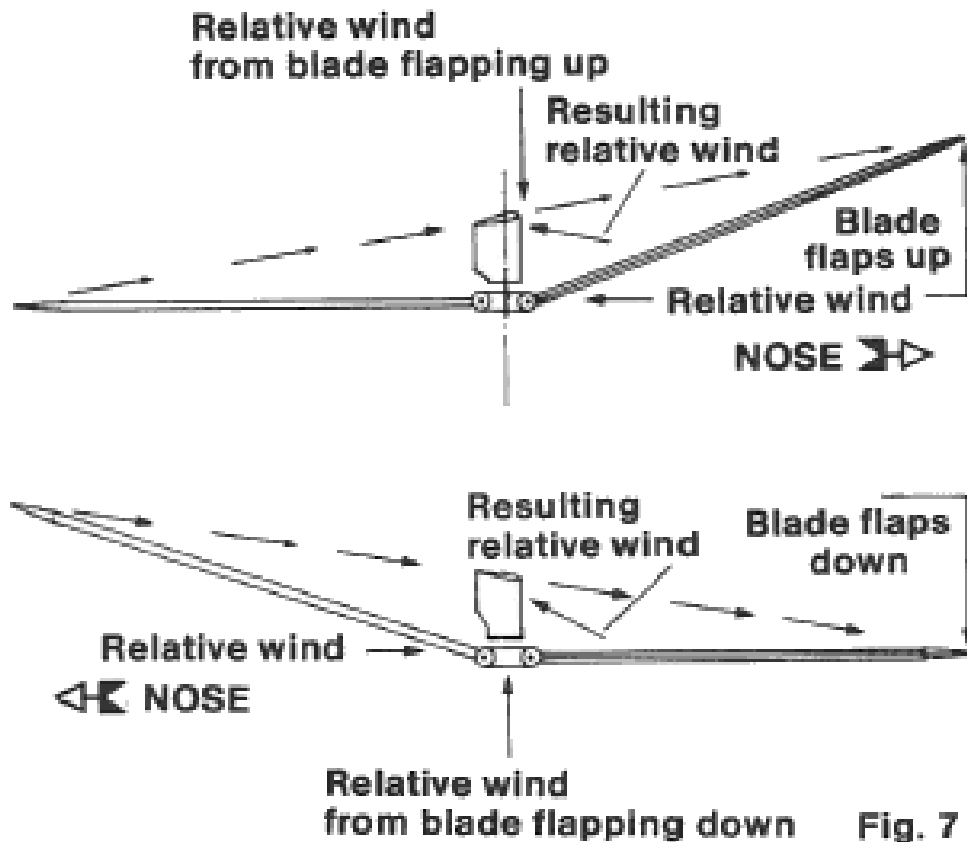

In normal flight, the forward speed of the autogiro adds to the air speed passing over the advancing blades and subtracts from the air speed that the retreating blades move in. As the blades advance, the increased air speed causes the blade to climb or "flap." As it does, it decreases its angle of attack (Fig. 7, left). This action effectively equalizes the lift on each side of the rotor disc and permits the Autogiro to fly level in forward flight instead of rolling because of the unbalance or asymmetry of lift across the rotor disc.

# Ground Resonance

**Any in-flight disturbance was usually quickly dampened out by the rotor lead-lag dampers. But on the ground, during run-up for take-off or just after touchdown, it was an entirely different experience.**

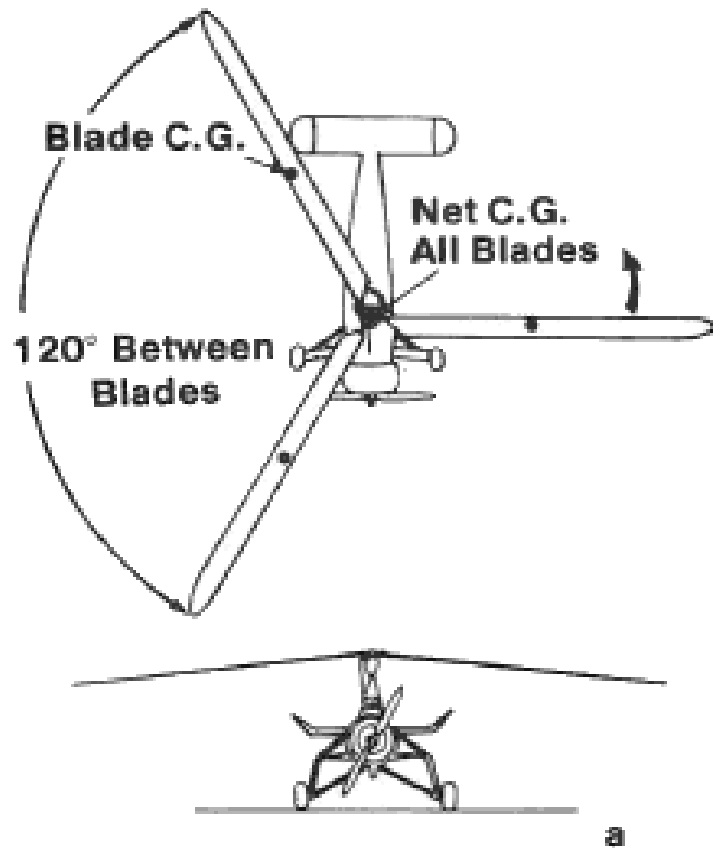

**Left: in figure “a” the rotor is stable because all three blades are equally spaced around the hub, 120 degrees apart.**

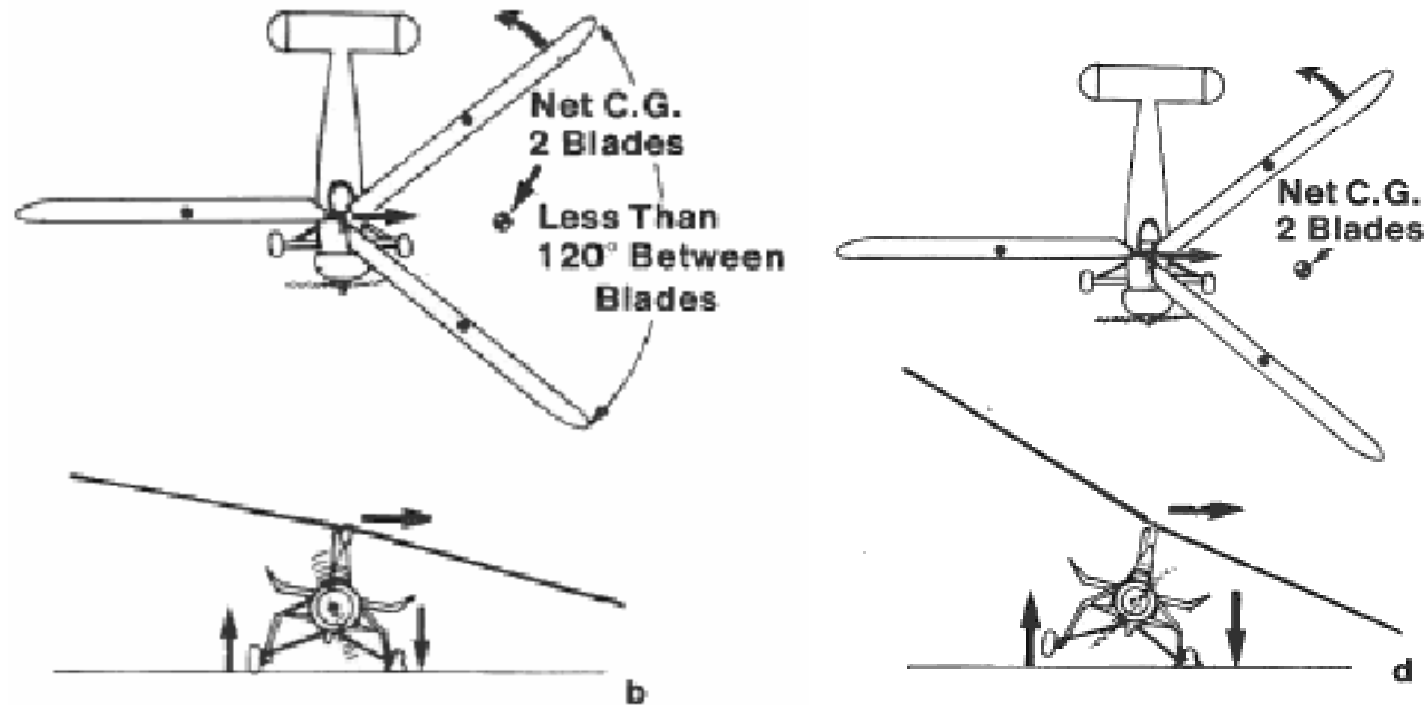

**Above:** In figure “b” (left), the rotor pattern has been disturbed and two blades are closer to each other than they are to the remaining blade. Although the C.G. of each blade has not changed, the collective C.G.’s of the two blades act against the remaining blade, with the collective C.G.’s at a new location and with their weights added together. This tries to pull the rotor head toward the C.G. of the two blades and because the landing gear tries to resist the autogiro rolling over, the tire compresses and the landing gear is compressed as seen in figure “d” (right). If the landing gear shock absorbing system (shock strut and tire) are not designed properly or not serviced properly, the reaction to their being compressed will try to push that side of the autogiro up at the same time the two blades that are closer together are on the opposite side of the Autogiro.

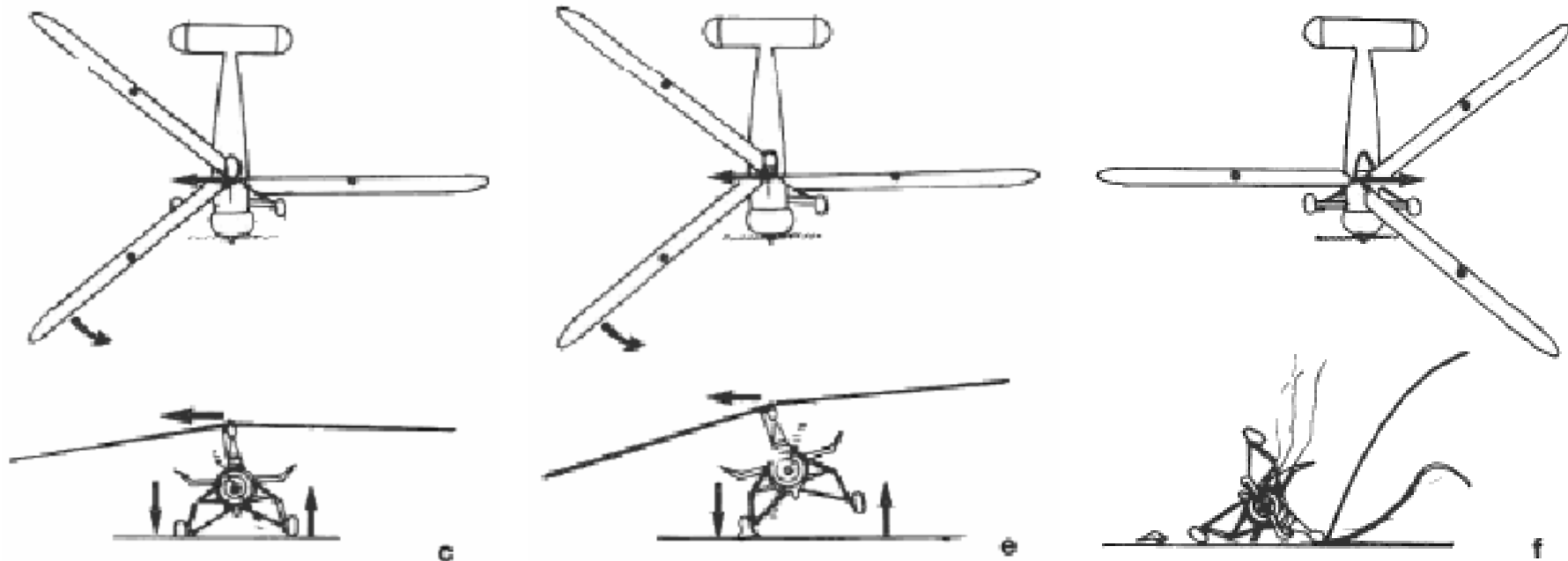

The combination of the weight and C.G. shift and the landing gear reaction put a stronger force into the Autogiro (figure "c," left). This can, if the landing gear does not dampen it out, build-up (figure "e," middle) with each revolution of the rotor until the Autogiro rolls onto its side (figure "f," right). As well, the Autogiro will also shake in a fore and aft direction, but because of the longer fore and aft stance, the overturn will be to one side or the other. There are no certain number of oscillations until the Autogiro upsets. If this happens on touchdown, the damage has been done before the pilot can react and there is little they can do in any event. If it happens on run-up for take-off, there is one chance; de-clutch the engine from the rotor drive and apply the rotor brake. This might cause all the blades to lag to the rear limit of their damper travel and they will be in an even spacing from each other. However, this is hypothetical - there is no record <sup>317</sup> of this action ever being performed during an Autogiro take-off.

**The overturning scenario depended on a number of factors. It could happen once oscillations began or it could rock without overturning. This phenomenon is known as “Ground Resonance” or “Ground Instability.” It was never a problem with four-bladed Autogiros because the four blades were wire braced to each other (it was difficult for the blades to get as close together as in the three-bladed system). Removing the wing from Autogiros (when three-bladed rotors with direct control in the rotor came about) brought with it narrow landing gears that did not resist the rocking as well as the wide-stance gear on the four-bladed autogiros with wings. Ground Resonance usually did not occur with two-bladed Autogiro designs because each blade always opposed the other blade uniformly. The three-bladed rotor system permitted two of the blades to be folded back alongside the third blade over the tail to make an ideal configuration for storage. The Autogiro could then be towed when the need arose (it was often more convenient and/or economical to tow it).**

# **Control-Stick Vibration**



***“...Conventional three-blade direct-control autogiros of the tilting-hub type are generally regarded as unsuitable for extended cross-country flights, largely because of the severe vibrations of the control stick that appears at air speeds above 80 miles per hour. The importance of the problem of stick vibration has been recognized by designers and several solutions have been proposed. Because the relative importance of the various elements of the control arrangement, as regards their contribution to stick vibration, has never been established, the tendency has been to devise an arrangement of the hub and the blades that will exclude all possibility of disturbing forces capable of causing stick vibration. Consequently, all the solutions proposed have involved radical departures from conventional arrangements and their development has been slow. As yet no entirely satisfactory solution has evolved. The fundamental cause of stick vibration is a periodic variation in the moment acting between the rotor and the fuselage at the lateral-control and the longitudinal-control trunnions...”***

**RE: excerpt from *Technical Notes – National Advisory Committee for Aeronautics – Flight Investigation of Control Stick Vibration* (June 1940)**

**It Flies!**



**Cierva's next design, the C.4, incorporated hinged rotors. For lateral control, ailerons were mounted on outriggers to the side of the aircraft. However, yaw and pitch control still came from a rudder and elevators. On January 17<sup>th</sup> 1923, the C.4 (above) flew, marking the first controlled flight of an Autogiro. The C.4 also demonstrated the Autogiro's safety in low speed flight. On January 20<sup>th</sup> 1923, just three days after its first flight, the Autogiro went into a steep nose-up attitude after an engine failure at about 25-35-feet. In an airplane, this would have almost certainly resulted in an unrecoverable stall. But the Autogiro just descended gently to the ground without damage to the machine or injury to the pilot. This low speed safety was demonstrated even more dramatically on January 16<sup>th</sup> 1925 when another design, the C.6, lost power after take-off at about 150-200-feet. The pilot was still able to turn the Autogiro around and bring it in for a safe landing, with only slight damage to the ma-**

322

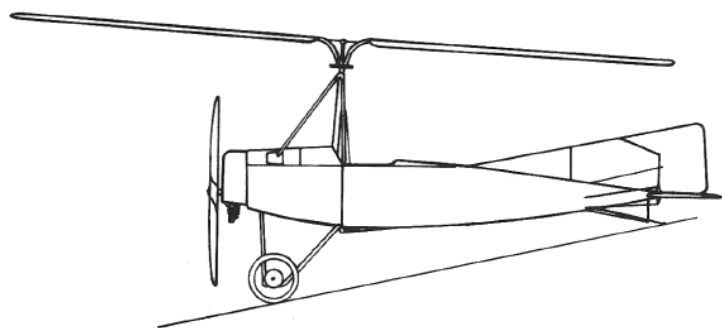
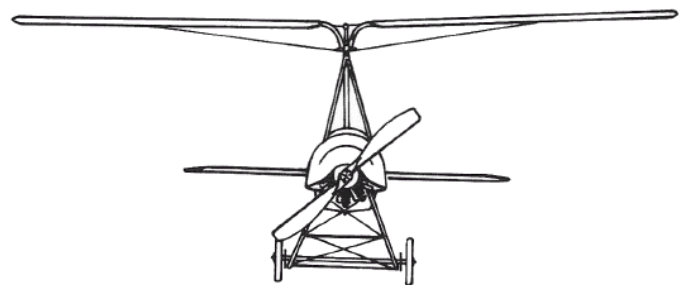
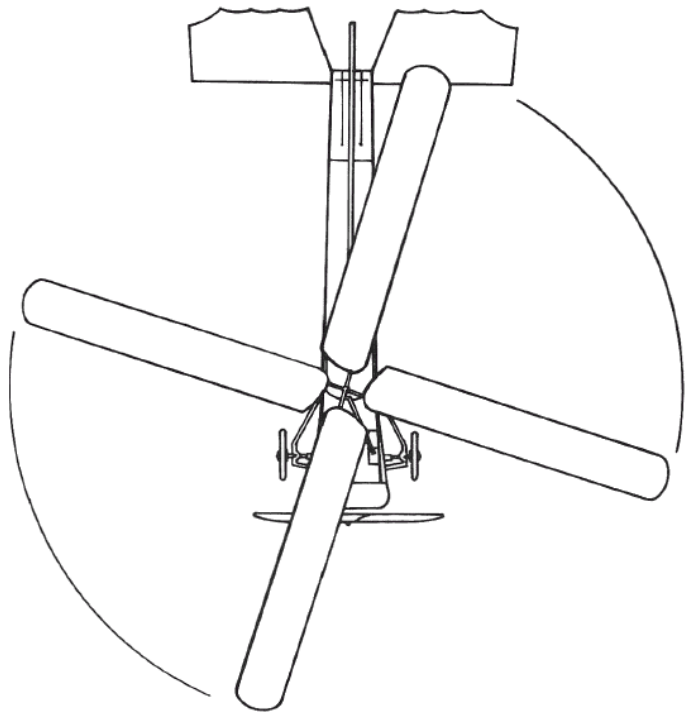

The four blades of the *Cierva C.4* prototype were articulated at the root and were thus able to flap vertically. The original model did not fly, but after various trials and modifications (such as the addition of ailerons on outriggers) the C.4 flew for the first time on January 17<sup>th</sup> 1923 at *Getafe Aerodrome* on the outskirts of *Madrid* and covered 183 meters. The *Autogiro* was moved to *Cuatro Ventros Aerodrome*, (also in *Madrid*) and at the end of January performed a closed circuit flight of 4 km in four minutes at a height of about 30 meters. Hinged, articulated blades thus proved the answer to the difficulties encountered in the previous types.

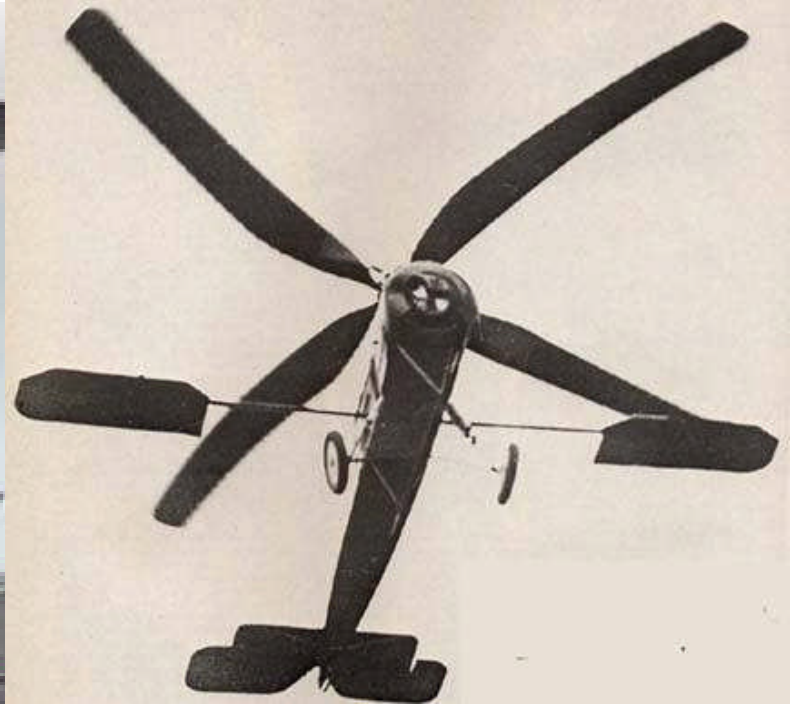
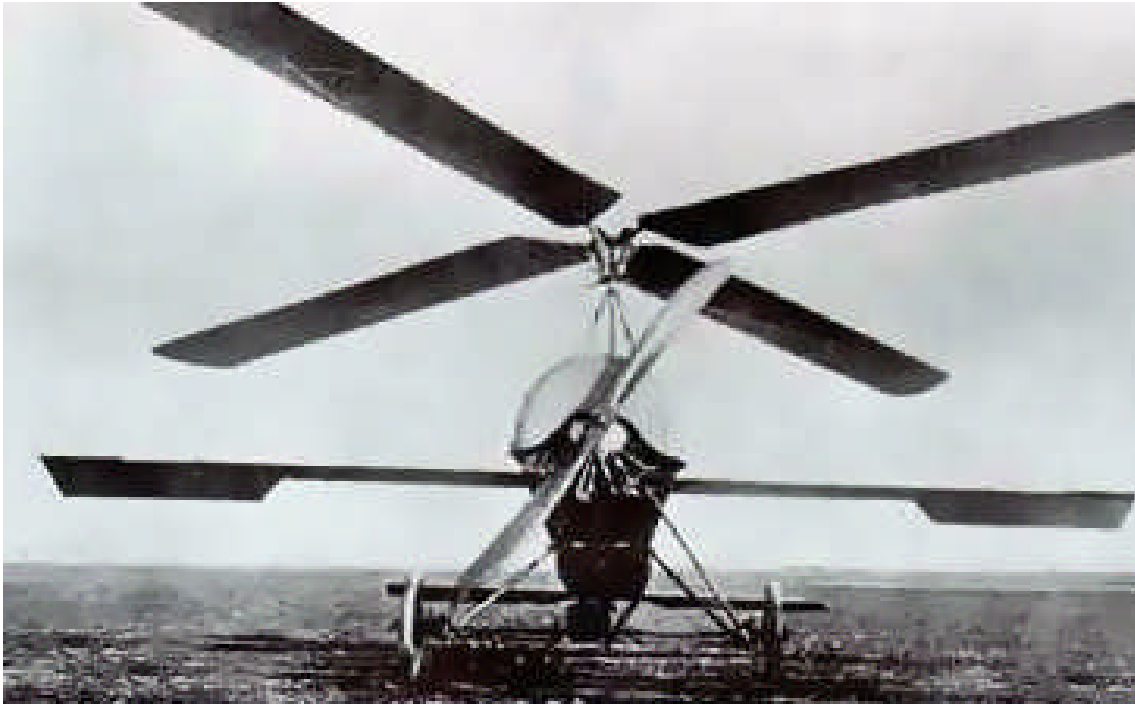

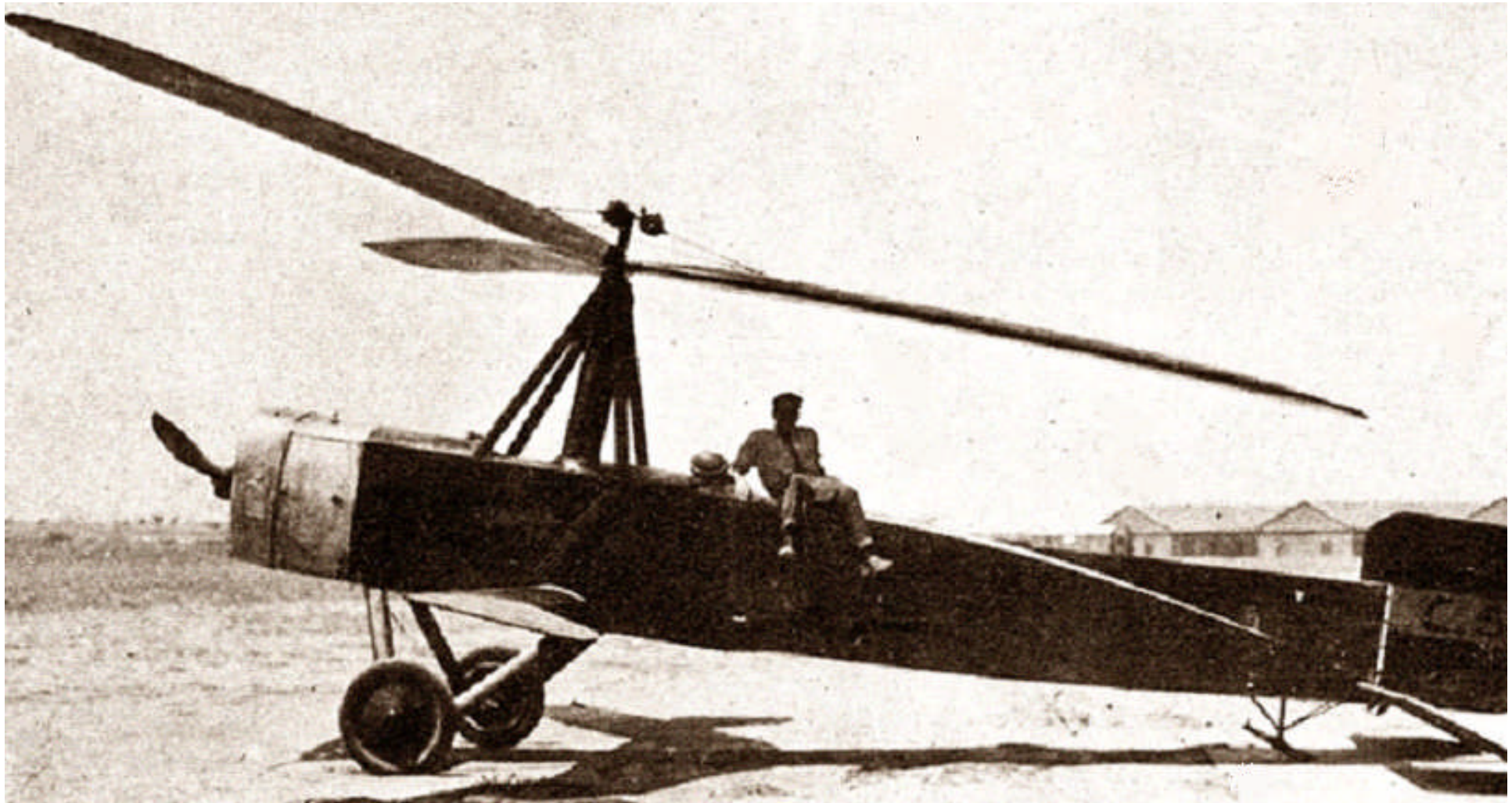

**Above: similar to the *Cierva C.3* (also equipped with a *Le Rhone 9 JA* 110-hp engine), the *Cierva C.5* (with a three-bladed rotor) first flew at *Getafe Aerodrome* in July 1923**

# **Suitably Impressed**

The *Cierva C.6*, unlike its predecessors which were financed from private sources, was developed with the help of subsidies from the Spanish Government and made its maiden flight in May 1924. It had an *Avro 504K* fuselage with ailerons on outrigger spars, a rotary *Le Rhone 9 JA* 110-hp engine and a four-bladed rotor with flapping hinges 10.97m in diameter and turning at 140 rpm (the rotor was designed to turn at up to 60 rpm). By means of a wound-rope spinning the rotor, the Autogiro's take-off was shortened considerably. On December 12<sup>th</sup> 1924, the first successful cross-country flight was made over the 12 km between the airports of *Cuatro Ventros* and *Getafe*. In October 1925, the C.6 was brought to *England* and performed a series of demonstrations at the *Royal Aircraft Establishment, Farnborough*. These were so impressive that the *Air Ministry* decided to order several Autogiros to be tried out by the *Royal Air Force*. This gave rise to the *Cierva Autogiro Company Ltd.*, which bought the rights to Cierva's patents. The firm of *A.V. Roe Hambel* (near *Southampton*) was selected to build the British C.6's under license. The *C.6C/D* received the designation/s *Avro Type 574/575* respectively and both were powered by a 130-hp *Clerget* engine.



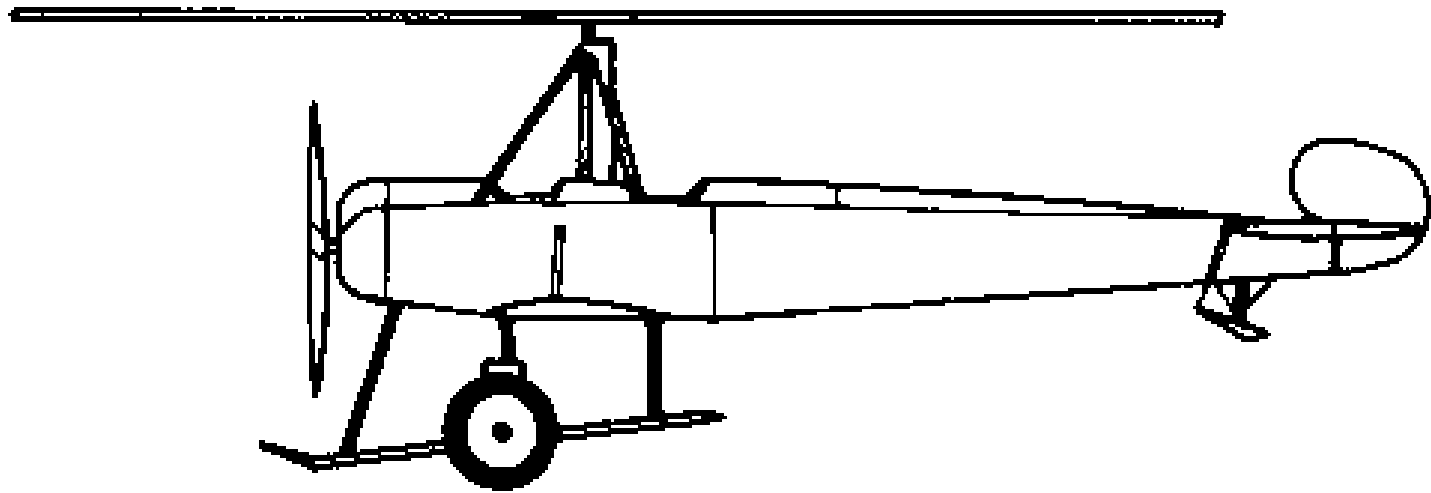





**Above: in September 1926, the C.6D was demonstrated at *Tempelhof Aerodrome* in *Berlin* before *Crown Prince Kaiser Wilhelm*. Following success with the C6D orders came in for the C.8, which was to fly in 1927.**



**Above: the C.7 designation was assigned to two machines built in *Spain* in 1926 by *Jorge Giros Loring* and whose power plant consisted of a *Hispano-Suiza* 300-hp engine. A C.7 was exhibited at the *Air Festival Madrid*.**

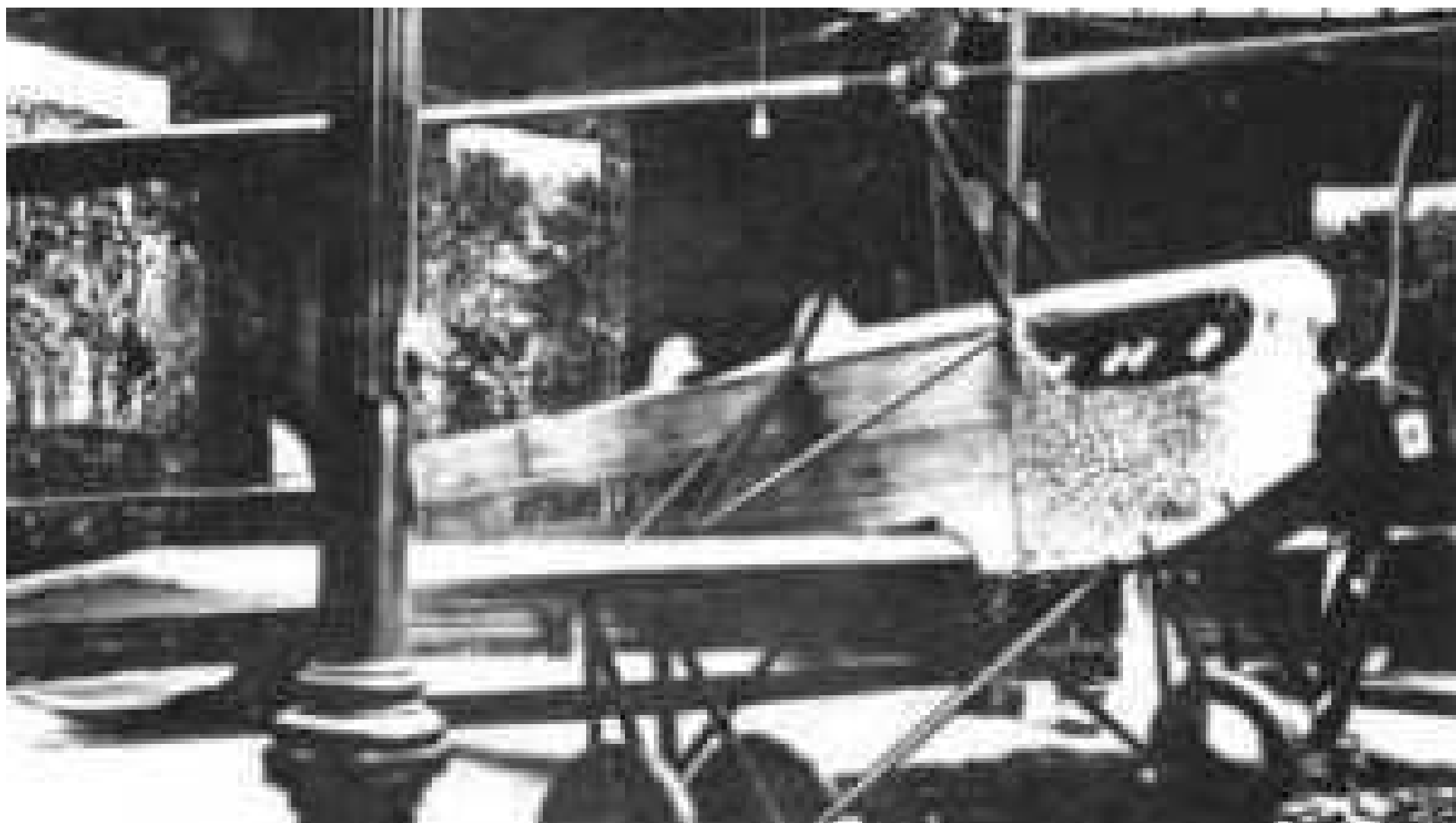

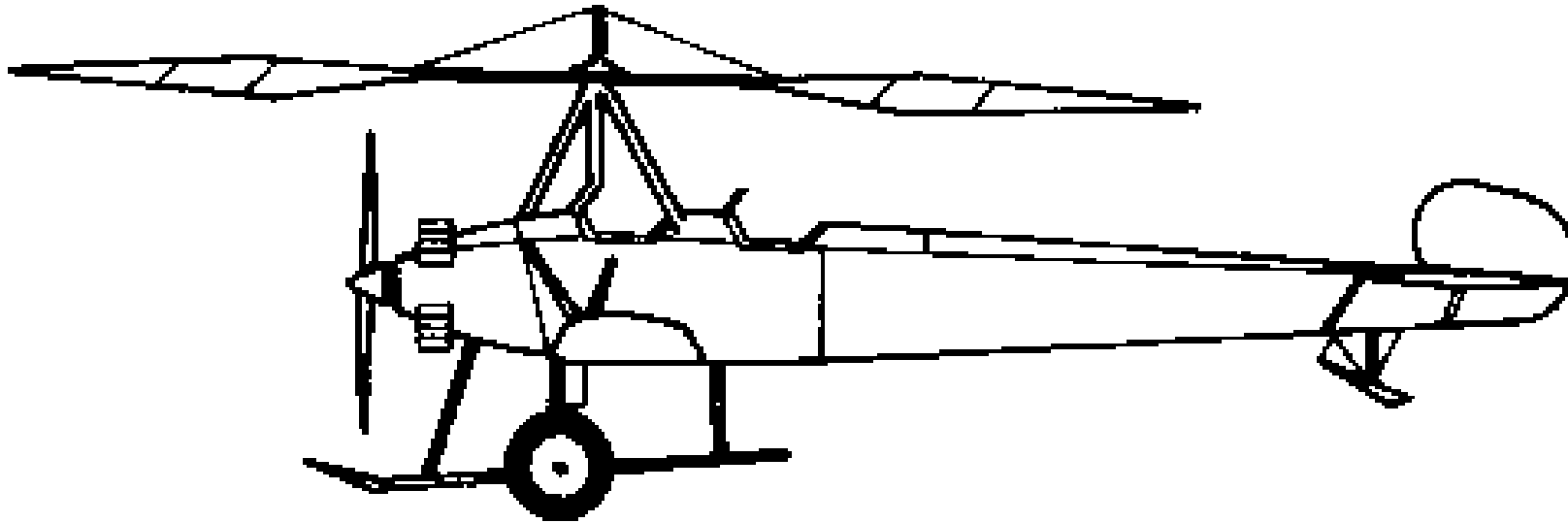

Cierva's first successful Autogiro (and the first successful rotary-wing aircraft of any kind), the *Cierva C.4*, took flight on January 17<sup>th</sup> 1923 at *Getafe Aerodrome* in *Madrid, Spain*. Over the next three years, Cierva made progressive improvements that resulted in the standard monoplane configuration for gyroplanes that remained in use until the mid-1930s. The greatest improvements came in the design of the rotor blades and the hinges, both of which would later prove essential for helicopters. Cierva constructed his first C.8 model, the C.8V, in close association with *A.V. Roe & Co. Ltd.* (commonly known as "Avro"). The airframe was based on the fuselage of the *Avro 552A*, a variant of the venerable *Avro 504* biplane. The most innovative component of the C.8V was its new four-bladed cable-braced rotor that incorporated drag hinges to reduce the stresses on the blades. The "V" in the model designation indicated the type of engine used in the variant - in this case, a *Wolseley Viper*. Cierva constructed six different C.8 configurations, all of which were experimental test-beds built to test improvements in Autogiro technology before a production model, the *C.19*, was to appear in 1929. Given the limited knowledge of rotary wing aerodynamics at the time and the necessity of relying on trial-and-error methods, it's not surprising that Cierva constructed two dozen experimental Autogiros before he completed a model worthy <sup>333</sup> of production.

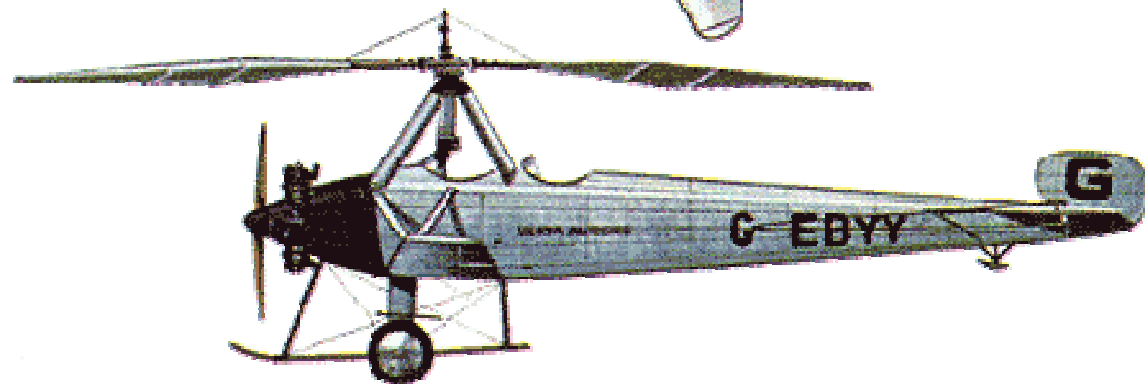
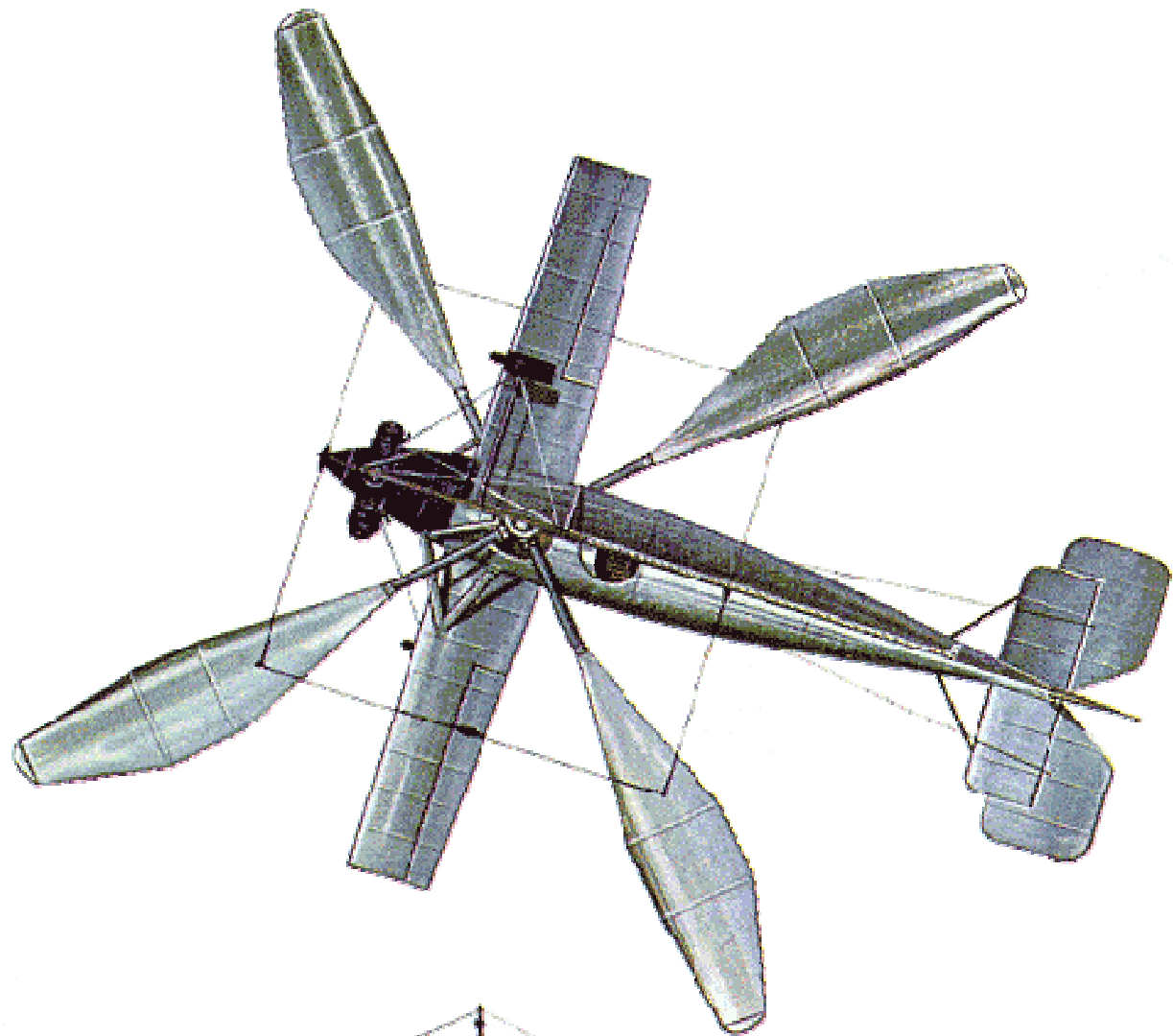



The most powerful of the six C.8s constructed was the two-seat C.8W (above) fitted with a 220-hp *Wright Whirlwind J-5*. Cierva had equipped the aircraft with an American engine at the request of its buyer, *Harold Pitcairn* (this was the Autogiro Pitcairn donated to the *Smithsonian Institution*). European engines turned counter-clockwise (when viewed from the rear) while the American *Wright Whirlwind J-5* turned clockwise, which caused Pitcairn some apprehension over its affects on rotor rpm. After Cierva confirmed that this would not be an issue, Pitcairn agreed to purchase a new C.8 with the *Wright* engine. On December 11<sup>th</sup> 1928, the C.8W arrived in the *United States* onboard the *S.S. Aquitania*. Pitcairn planned to have the Autogiro make its flight on the twenty-fifth anniversary of the *Wright Brother's* first powered flight (December 17<sup>th</sup> 1903) at his *Bryn Athyn, Pennsylvania* airfield. However, he was conservative when dealing with the experimental testing of the newly reassembled aircraft and was extremely anxious that all should go well on the first flight. Thus, not until December 18<sup>th</sup> 1928 would the C.8W perform the first flight of an Autogiro in the *United States*, with Cierva test pilot *Arthur Rawson* at the controls. Pit-<sup>335</sup>cairn flew the aircraft the following day.





Whatever doubts Pitcairn had concerning the potential of rotary-wing aircraft evaporated as he completely reorganized his company to support Autogiro production. His first step was to acquire the American patent rights to Cierva's inventions and to manage and license them under the direction of the *Pitcairn-Cierva Autogiro Company of America*. This enterprise (later renamed the *Autogiro Company of America*) would remain separate from the production side of *Pitcairn Aircraft*, which would become the *Pitcairn Autogiro Company, Inc.* in 1933.

***“...had regarded the whole Pitcairn adventure in the U.S. as a large testing ground on which the giro would be given a thorough workout under all sorts of conditions, while he perfected the design for markets in Europe...”***

***Fortune magazine, March 1936***

**RE: after negotiations in early 1929, Cierva and Pitcairn agreed that the *Pitcairn-Cierva Autogiro Company (PCA)* would be formed in *America* with the rights to license Cierva’s patents and *Harold Pitcairn* would join the English company’s board. The price was \$300K, paid for by the sale of Pitcairn’s airmail company; *Eastern Air Transport*, to a group headed by *Chandler Keys* and *Glenn Curtiss*. The purchase of Eastern Air Transport for \$2.5 million was completed just weeks before the stock market crash in October 1929 and Pitcairn’s airline would eventually become *Eastern Airlines*. Cierva eventually came to be seen by Harold Pitcairn as a rival, and some have suggested that Cierva had come to see the American rotary-wing industry as a “proving ground” for his aircraft improvements. Even so, it’s recognized universally that Cierva’s insight, enthusiasm and vision saw the development of the conceptual basis and the mechanical foundation of the practical helicopter. Cierva, as did Pitcairn, resisted mechanical complexity and saw in the Autogiro a rotary-wing air-  
craft that offered the greatest advantage with the least complication.**

**That Some Day**

# PITCAIRN AIRCRAFT OFFERS AMERICA THE

# PITCAIRN *autogiro*

BECAUSE THE AVERAGE MAN AND WOMAN CAN FLY IT . . . AND WITH A CONFIDENCE IN THEIR OWN ABILITY IMPOSSIBLE IN AVIATION UNTIL NOW

The Pitcairn Autogiro puts an entirely new meaning into the word "flying." It turns objective interest in aviation into personal interest. It makes flying possible for you, personally.

The distinguishing characteristics of the Autogiro which give you confidence to take the controls yourself, are these:

The Pitcairn Autogiro takes off at extremely low speed, after but a short run, and has an acute angle of climb which insures the clearing of obstacles. It can maintain level flight at a low speed approaching 20 m.p.h. in still air. It can momentarily arrest its flight in mid-air and "hover" over one spot. Or it can fly at a high speed comparable to that of conventional airplanes of like power. It can descend, with motor on or dead, almost vertically—and more slowly than a man in a parachute. It can land in very restricted areas, and with no forward speed

at all. The skid and slip lose their danger—and the Autogiro cannot tail spin. Any accredited pilot can fly an Autogiro after but a few minutes of verbal instruction—while the novice will find that learning to fly an Autogiro is very much like learning to drive a car.

Able to move slowly, and able to take off and land within an incredibly small space, constantly under complete control, the Autogiro broadens the utility-scope of aircraft beyond anything so far attempted. It must indeed make thousands of us feel that one of humanity's oldest dreams is becoming a reality.

The first Pitcairn Autogiros specially built and priced for individual ownership—a passenger-and-pilot—with 120 h. p.—will be shown at the National Aircraft Show in Detroit, April 11-19.

**PITCAIRN AIRCRAFT INCORPORATED**  
Willow Grove Pennsylvania



THE FIRST PLANT TO PRODUCE COMMERCIAL MODELS OF THE AUTOGIRO IN THIS COUNTRY

"SOME DAY WE SHALL FLY AS TODAY WE MOTOR" . . . YOU HAVE LIVED TO SEE THE DAWN OF THAT "SOME DAY" . . . AT THE NATIONAL AIRCRAFT SHOW IN DETROIT, APRIL 11-19

***"...Because the average man and woman can fly it...and with a confidence in their own ability impossible in aviation until now..."***

***"Some day we shall fly as today we motor... You have lived to see the dawn of that 'Some Day'..."***

**RE: excerpts (highlighted) from a 1931 Autogiro advertisement from Pitcairn Aircraft**

***“A very interesting type of heavier-than-air craft is the Cierva autogyro. It is neither a helicopter nor an airplane. It consists of a body or fuselage very similar to that of an airplane. In its nose there is a motor and an ordinary type of propeller. Its small stubby wings and tail surfaces are somewhat similar to that of any airplane. The remarkable feature of this machine is the windmill, or rotary wing which is mounted over it. This windmill, or rotor as it is called, is not actuated directly by any power from the engine but is made to revolve by the airstream from the propeller striking against it. When an ordinary airplane takes off in flight, its propeller gives it speed through the air and makes air pass under the wing at such a rapid rate that the airplane rises. With the autogyro, instead of the wing being fixed in position, it rotates and goes through as many particles of air in a given time as the wing of an airplane does; but with the windmill, instead of a great deal of forward motion being required, it is accomplished in one place by rotation...The machine can be made to hover over a certain place when climbing it upward. It can be brought straight down to the ground and landed on a place without any forward motion...The autogyro has been very successful in its flights and promises a great deal for the future, where machines are required to land on the top of a building, a small field, in a forest or the top of a mountain.”***

**General William “Billy” Mitchell, U.S. Army Air Corps**



Then followed the models *Cierva C.9*, *C.10* (in 1927) and the *C.12* built by *Avro* (in 1929). A *C.12* was fitted with floats so that when it flew from the *Port of Southampton* in April 1930, it entered aviation history as the first rotary-wing seaplane. Called a “Hydrogyro” (above), it was powered by an *Avro Alpha* 100-hp engine. Designations *C.15* and *C.16* didn’t get past the design phase, since the following was the *C.17 (Avro Type 612)*.  
Above: caption: “First ever Hydrogyro Cierva C.12 test, April 25<sup>th</sup> 1930”



**A C.8 designated C.8L (left) (with an *ADC Cirrus III* 90-hp engine and a fuselage based on the *Avian IIIA*) flew in October 1928 piloted by Cierva. It was underpowered and a second version was built with the designation *C.17 Mk II* (above). Though it had an *Avro Alpha* 100-hp radial engine, this model also had little success and was converted into an *Avian* in 1935.**



**Above: the *C.18* designation was for a two-seat closed-cabin machine built in *France* in 1929 by *Weymann-Lepere*. Powered by a *Salmson AC7* 195-hp engine, only one was ever built.**





The most prolific of experimental designs by Cierva was the *C.19*, of which a number of variants were built. The *C.19* marked the beginning of a series of *Gyroplanes* designed from the beginning as such and was the first to use an auto-start to rotate the rotor (a task that so far had been performed by a rope). The three *C.19 Mk I* models had *Armstrong Siddeley Genet II* 80-hp engines. They were followed by *C.19 Mk II*, *C.19 Mk IIA* (with improved rotor head), *C.19 Mk III*, *C.19 Mk IVP* and a *C.19 Mk V* (experimental) were built. All of them were powered by a *Genet Major 1* 105-hp engine.

Above: *Cierva C.19*

Left: *Juan de la Cierva* with a *C.19* at 344 *Hamble* (1929)

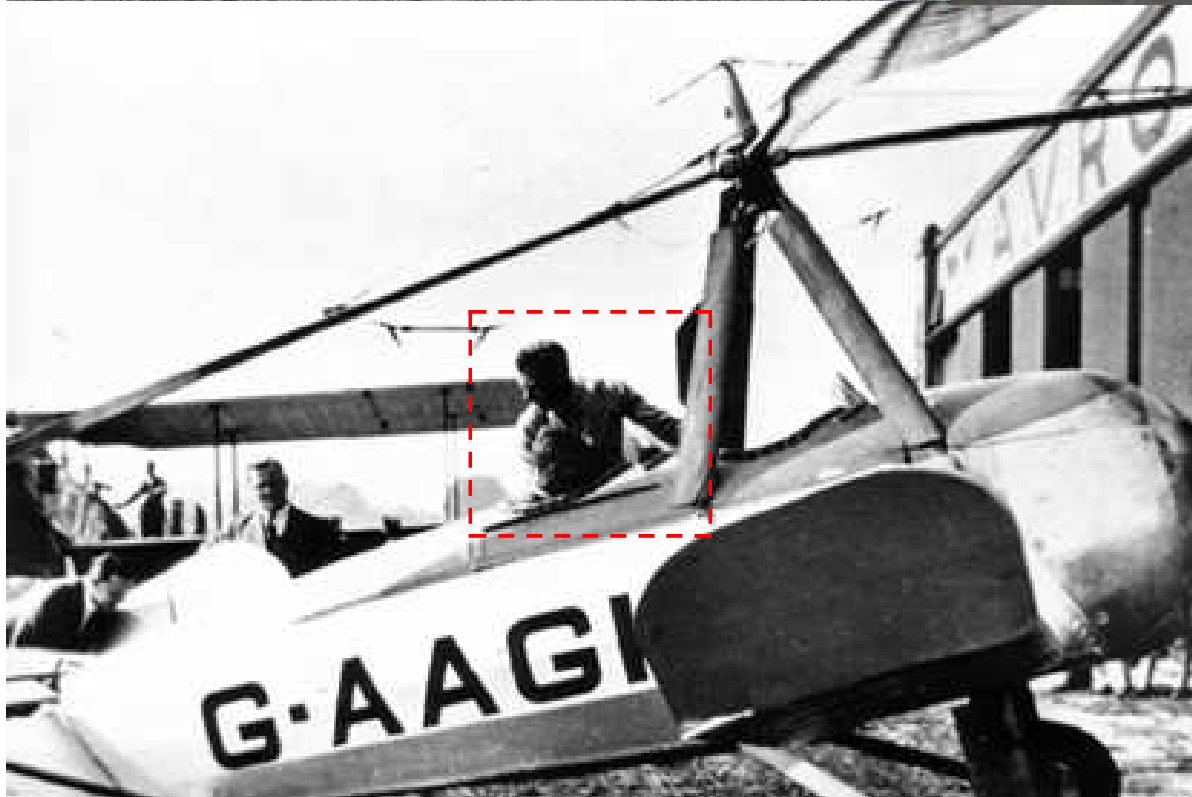

The C.19 had a deflecting tail plane (top L&R) tilted up (to deflect the slipstream up into the rotor disc to give it a start) and was built with a host of subtypes (*Mk I* thru *Mk V*). A total of twenty-eight of all the variations were built). The C.19 had a short stubby fuselage and, significantly, the C.19 *Mk V* had a handle in the cockpit for direct control of the rotor. Even the *Prince of Wales* came down to inspect the machine (left).<sup>345</sup>



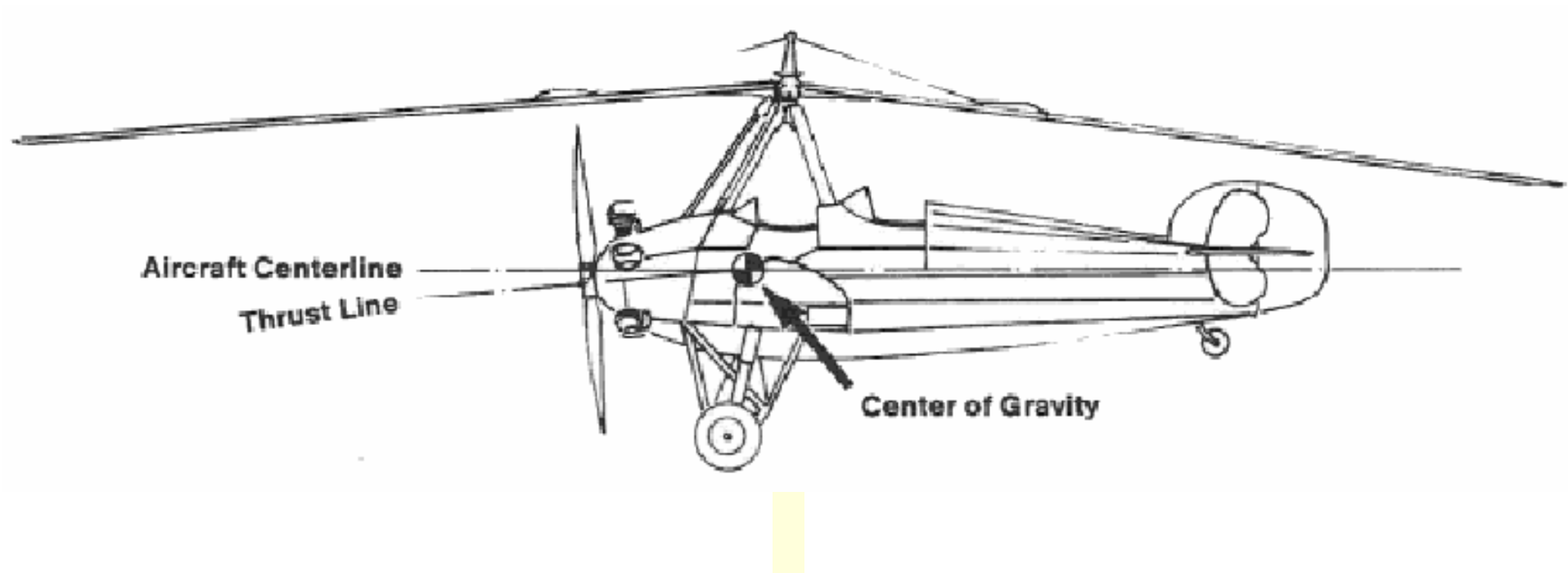

**Above: Cierva Autogiro's had their propeller thrust line tilted down (about five degrees). This was done to blow air on the rotor (in order to keep it turning). The tilted engine caused the thrust line to pass through the C.G. of the Autogiro which was unusually high (because of the extra weight of the rotor system high above).**



**Top:** Designated the C.20, several C.19 Mk IV's were built under license by *Focke-Wulf* of Germany using a *Siemens Sh14 B* 150-hp radial engine.  
**Bottom:** Focke-Wulf "Heuschrecke" (C.20) in flight

The *C.19* had a conventional airframe, a two-seat fuselage carrying a small span wing with ailerons (to relieve rotor loads in level forward flight) and a single radial engine in the nose. The un-powered, free spinning rotor had four wire braced blades (three cantilever blades in the *Mk IV*) and was mounted on four struts over the forward cockpit which met together to form a pyramid. The *C.19 Mk I - IV* did not have the tilting rotor head and associated hanging control column of later Autogiros (like the *Cierva C.30*). Instead, control was by the ailerons, elevators and rudder via a conventional column - a system that only worked effectively when the airspeed was high enough. A major engineering refinement in the *C.19* was the means to mechanically start the main rotor spinning. In earlier *Cierva* designs, the rotor had to be turned by hand or by pulling a rope (unless there was space for a take-off run). In the *C.19 Mk I*, this was done aerodynamically. The tail unit of this mark was a biplane structure with end-plate fins and rudders. To start the rotor, elevators and tail planes were fixed in a near vertical position and the engine started. The wash from the propeller was deflected upwards by the tail unit through the rotor, rotating it. For the first time, this made the Autogiro independent of ground crew at start making private ownership practical. In the *C.19 Mk IV*, the rotor was started directly from the engine via a clutch mechanism (as in all future Autogiros). This allowed the elaborate biplane empennage to be replaced by a more conventional monoplane tail plane. The single central fin was low and of correspondingly deep chord, to avoid being struck by the rotor. The *C.19 Mk IV* had a three bladed, 34-foot diameter cantilever rotor. The designation *C.19 Mk IVP* was also used (the "P" standing for production) that started in 1931.

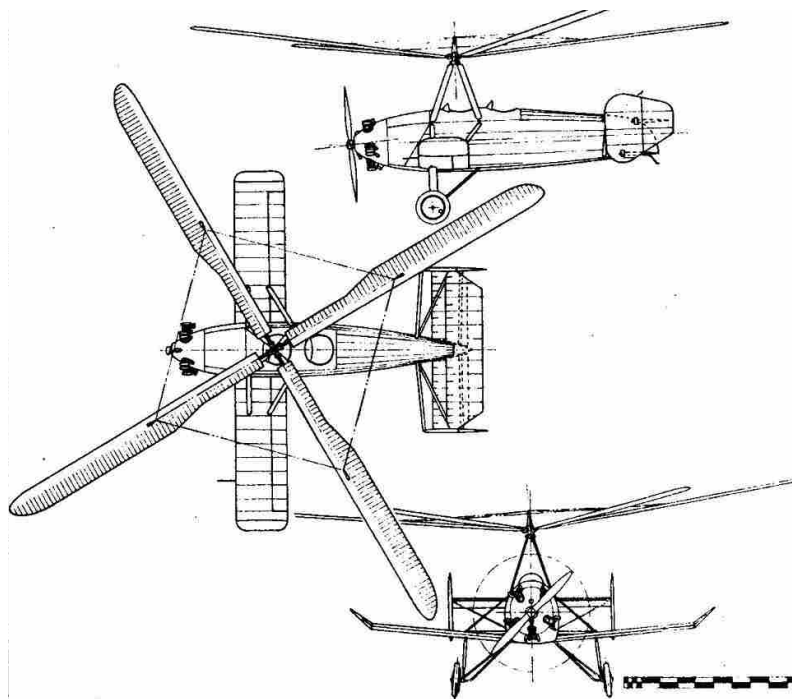





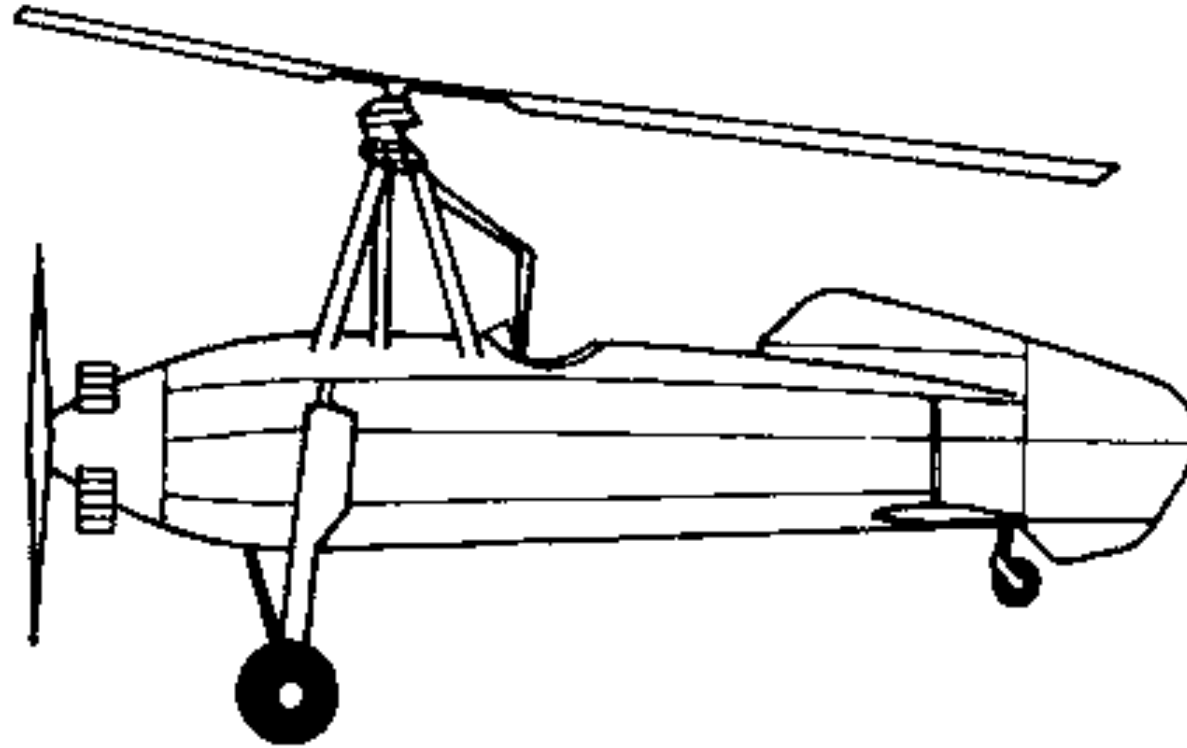

The final variant was the solitary *C.19 Mk V* (above). The aircraft style controls of earlier Autogiros depended on airflow past ailerons, rudders and elevators; during the slow forward speed phases of take-off and landing, these were ineffective and accidents resulted. The *C.19 Mk V* lacked the small wing and all moving control surfaces, relying instead on a tilting rotor head. Using a long control arm that reached to the rear cockpit, the pilot could direct the aircraft by tilting the plane of rotation of the rotor. After a period of experimentation, the *C.19 Mk V* flew with a small fixed tail plane and a two-bladed rotor (this control system was adopted for the *Cierva C.30*).

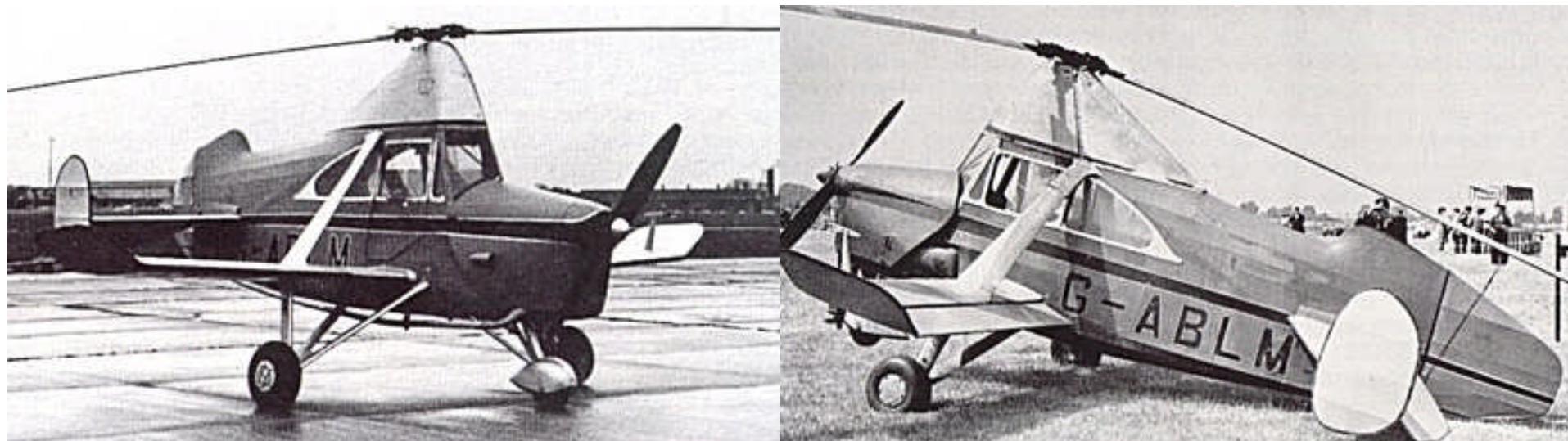

**Designation C.21 was assigned to a French project while C.22 and C.23 were assigned to an upgrade project. The *Cierva C.24* (above L&R) was a two-seat gyroplane with cab, designed and built by the *de Havilland Aircraft Company*. It was propelled by a *Havilland Gipsy III* 120-hp motor, *Tripal* rotor and a *DH.80A Puss Moth* fuselage. It first flew in September 1931 with Cierva at the controls. Later, a two-bladed rotor was provided and the one-off machine was re-designated C.26. In 1932, it toured several European countries. It is preserved at the *Mosquito Aircraft Museum* at *Salisbury Hall, Hertfordshire, England*.**

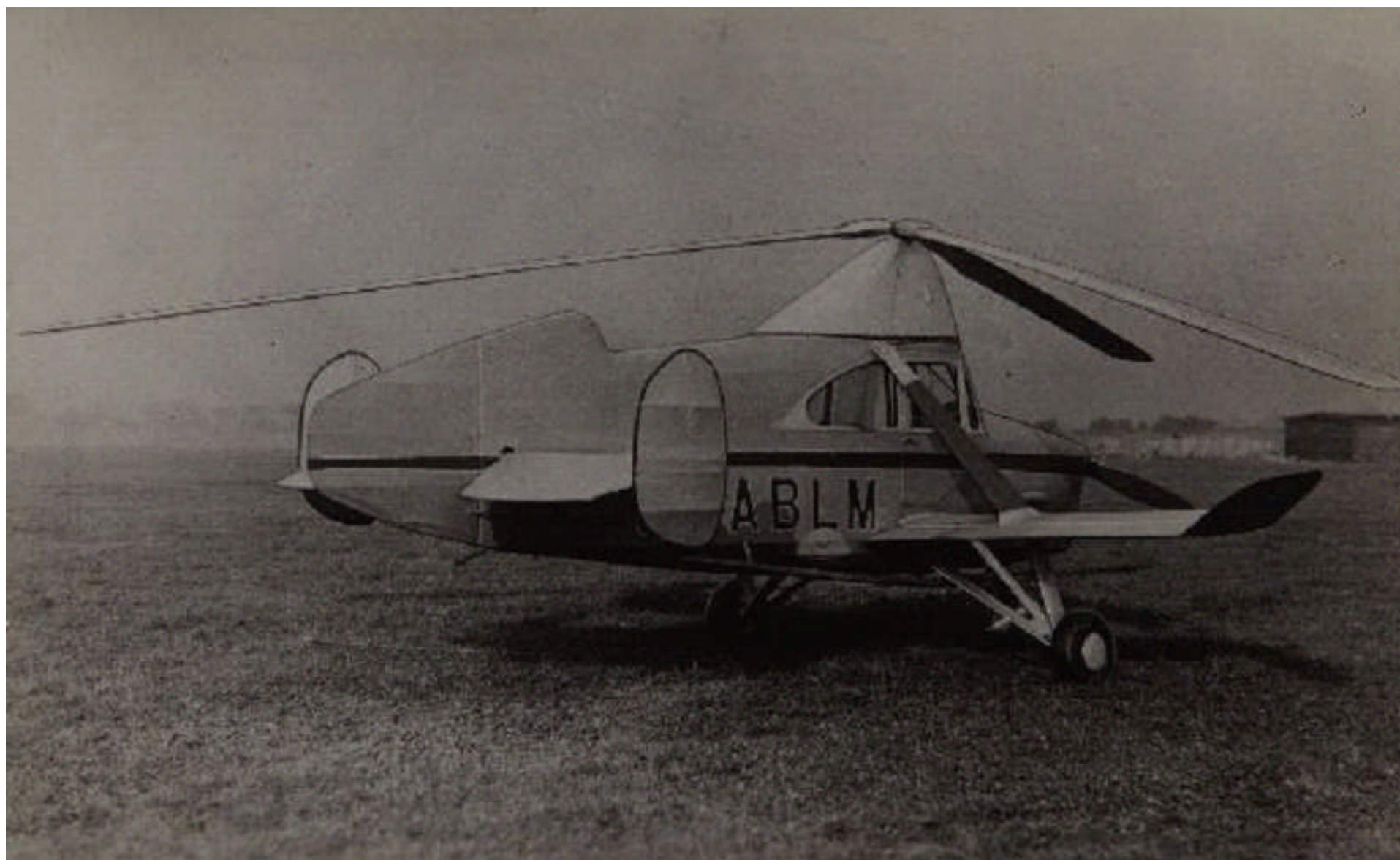



CIERVA C.25

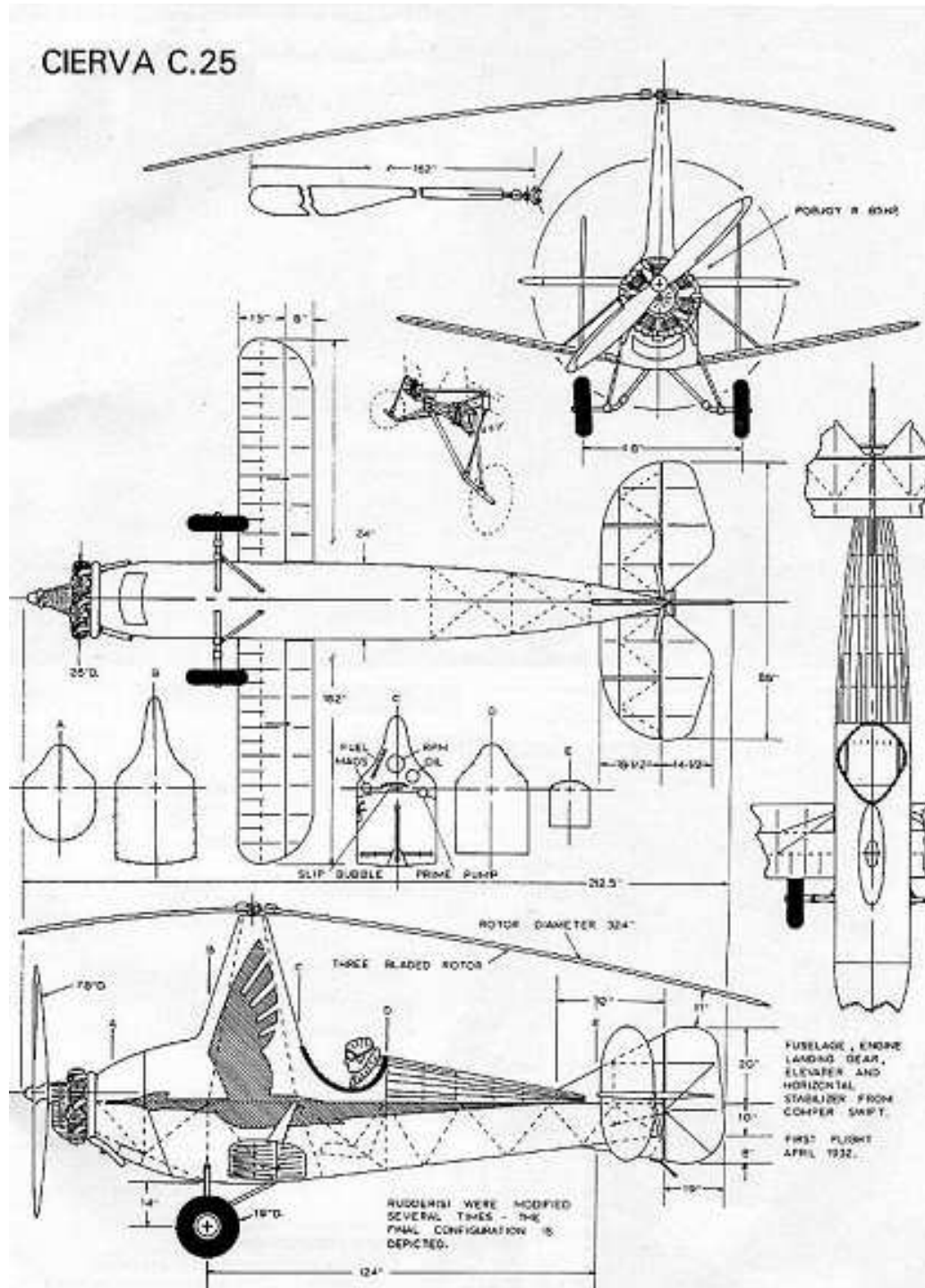

**“...the Cierva C.25, designed and built by Comper Aircraft in 1931, was a serious attempt to produce a cheap sporting autogyro...an autogyro version of its successful single-seat Swift...Comper’s autogyro utilized a more-or-less standard Swift airframe, adding a towering motor pylon, shorter wings and a different but, at first, conventional tail unit...A decision to go ahead was made in March 1931...”**

**Aeroplane Monthly, June 1989**

**RE: the C.25 was one of the smallest gyroplanes produced. It was a single-seater built by Comper Aircraft and flew in early 1933. The fuselage was based on the Comper Swift model. Modified tail surfaces and wings with an Falls Pobjoy R 85-hp engine. Despite its good performance, it did not obtain production orders.**



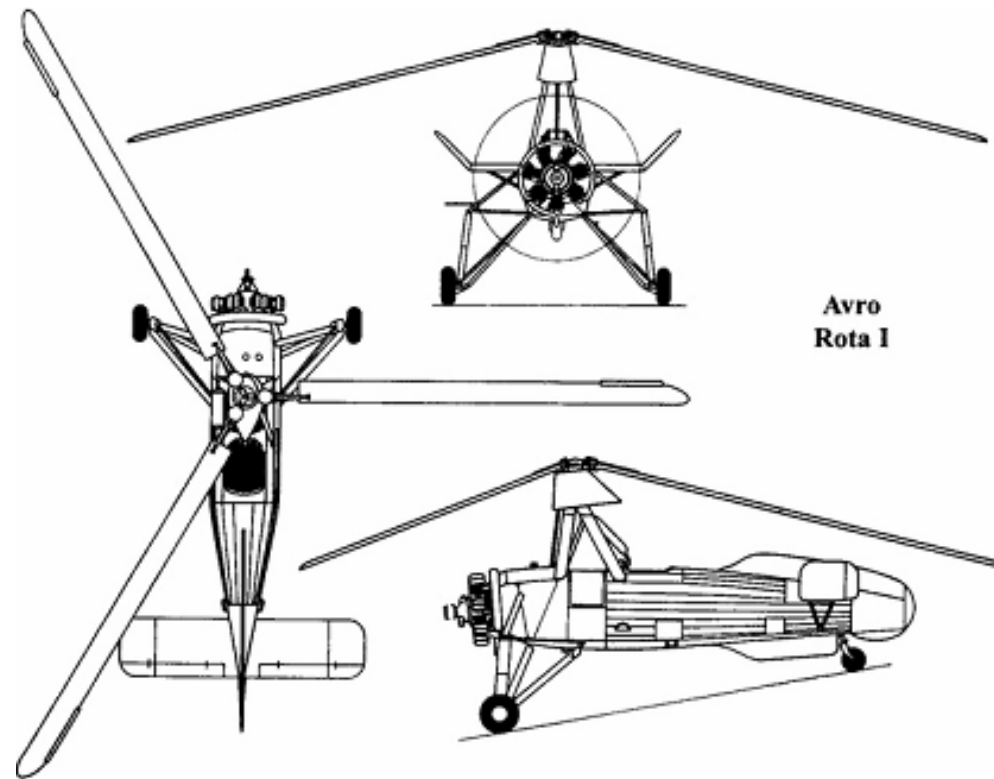

The *Cierva C.30A* (above) marked a major step forward in rotorcraft development, being the first production Autogiro in which the engine was geared directly to drive the rotor blades for take-off. The degree of direct control was increased still further by having the control column, which acted directly on the rotor, suspended from the pylon so that the rotor head could be tilted in any direction to produce the maneuver desired. The new-style control system was first installed in a *Cierva C.19* (designated *Mk V*) with a 100-hp *Genet Major I* engine. This was basically a *C.19 Mk IV* modified to have a clutch and transmission shaft, a tilting rotor head and (later) a small, fixed tail plane.

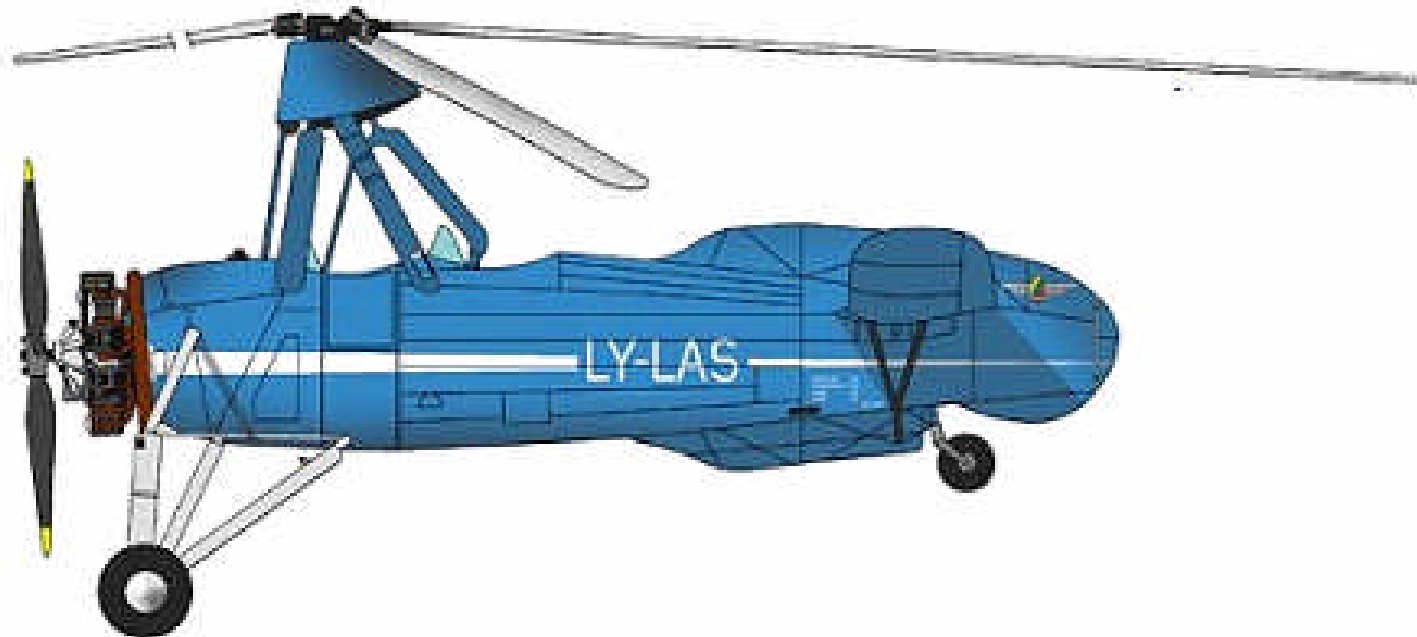
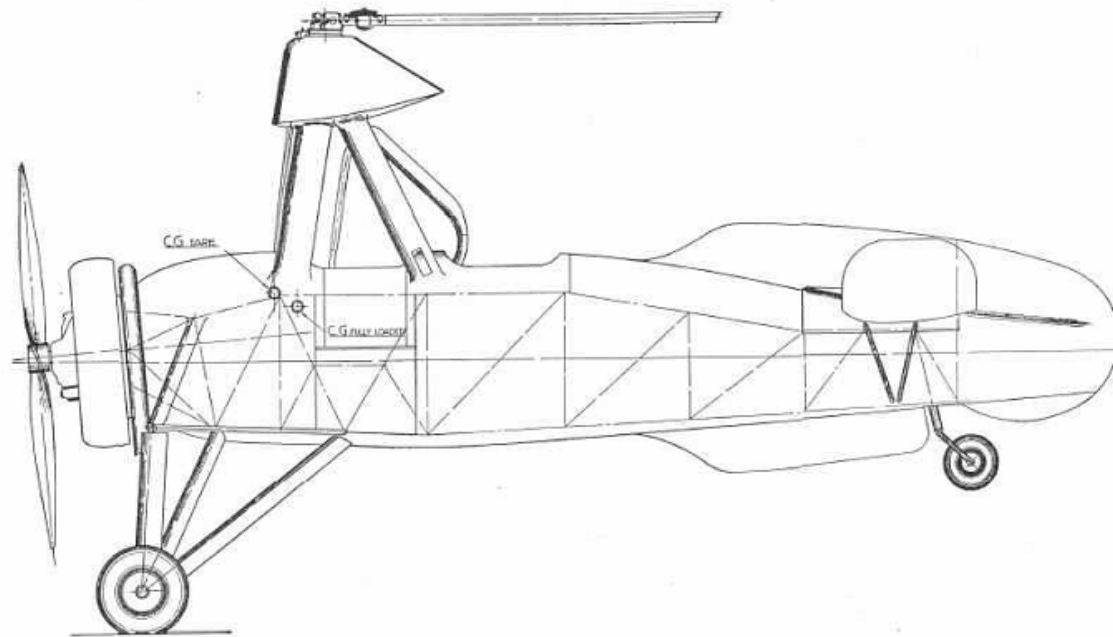



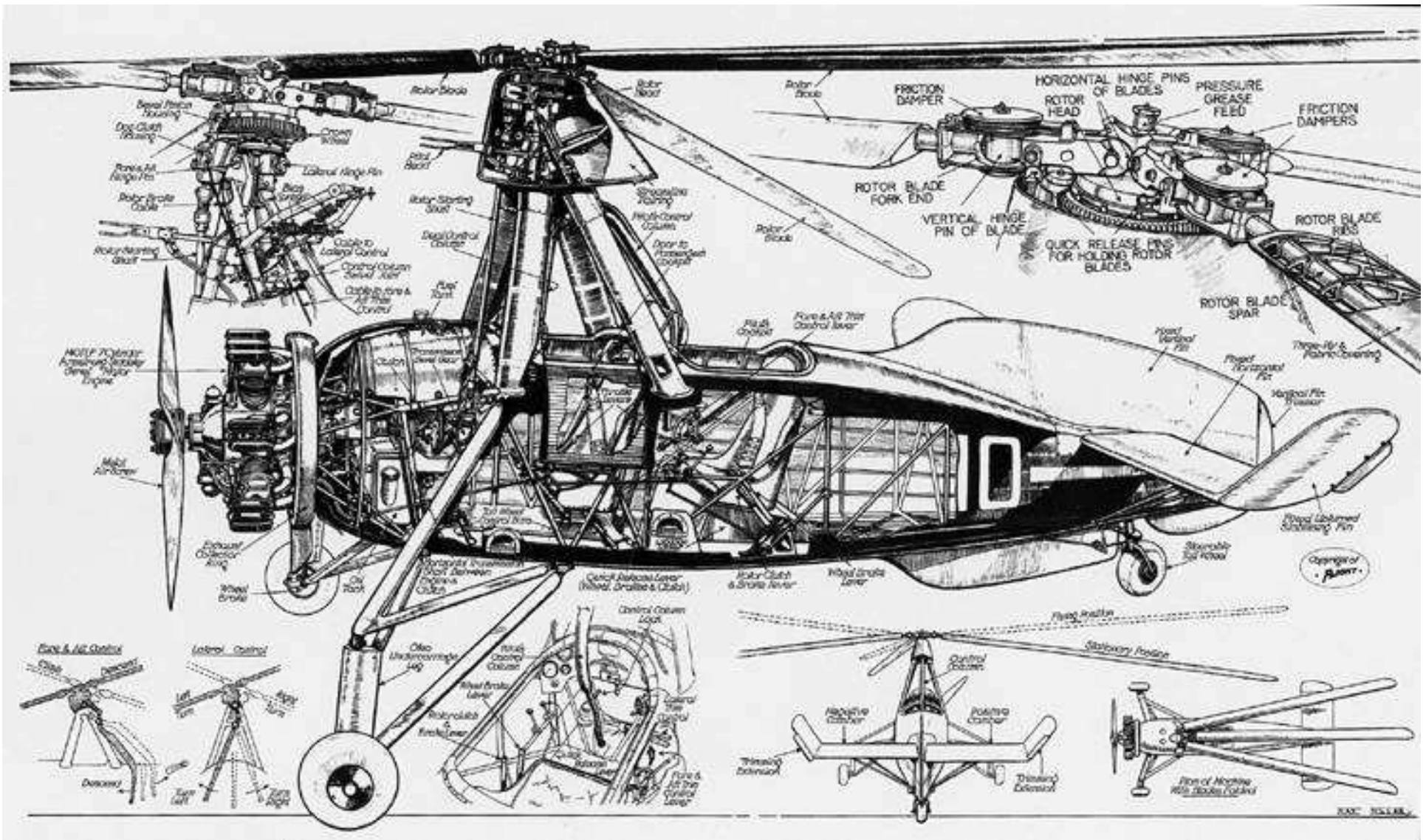

**Above:** caption: “Cierva C.30A. The Cierva was a practical non-stalling production Autogyro with cantilever rotor and reliable shaft and clutch for direct engine-to-rotor starting. About 70 C.30s were built under license by A.V. Roe, and a further 75 were produced in France and Germany. An example is kept in the Science Museum, London.”

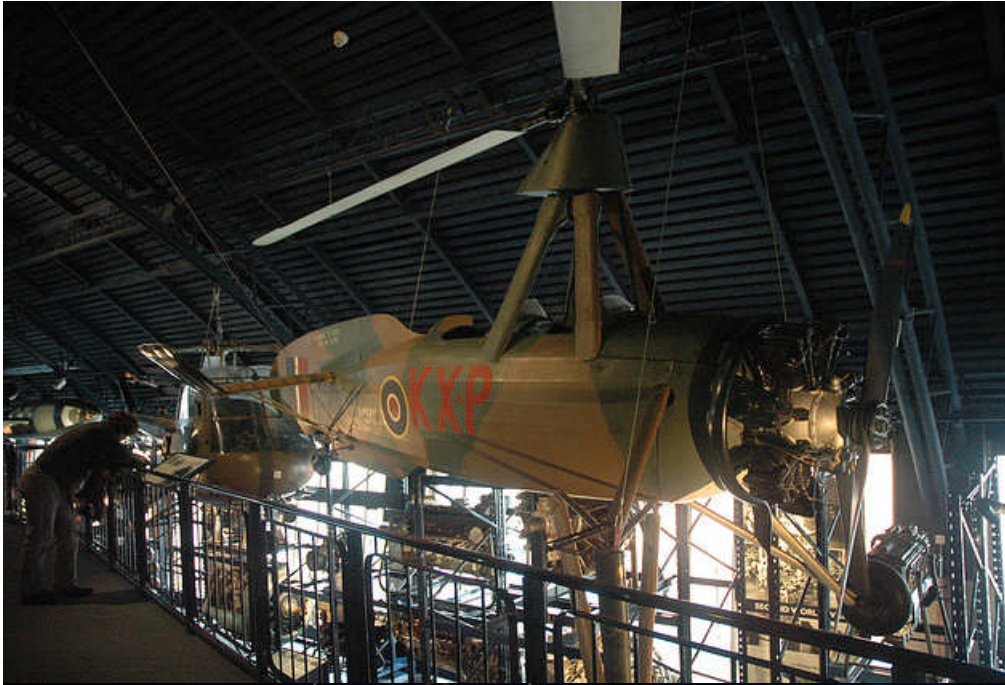

**Above & Left: Cierva C.30 –  
*Science Museum, London***



**Above:** caption “G-ACIN was one of the first C.30 Autogiros and had a simple under-carriage design. G-ACIN was used by the Metropolitan Police to monitor opposing Communist and Fascist rallies in Hyde Park. Despite its radio equipment not working properly, the mere presence of the autogyro above the mutually hostile crowds on 9 September 1934 kept public order and arrests to a minimum.”

**Left:** caption: “A.V. Roe built Cierva C.30 Autogyro G-ACIO was used by the Metropolitan Police to monitor the 1935 FA Cup Final held at Wembley Stadium”<sup>362</sup>



**Above: caption: “Cierva Autogyros set-up for filming a newsreel, Hamble 1930”**



The prototype C.30 (above) differed chiefly in having a tripod rotor pylon and dihedral on the tail plane tips; the fuselage was modified from a standard *Cierva C.19*. The first customer for the production C.30A was the *Royal Air Force* for whom the type was built by *Avro* and given the name “*Rota*.” During 1933, the C.30 prototype was converted for jump-start trials with a modified rotor head (in 1936 another prototype made the first genuine vertical take-off by an *Autogiro* by keeping the engine and rotor system engaged throughout the take-off sequence). This machine was, in effect, the prototype for the C.40, five of which were ordered for the RAF as the *Rota II*. These were built by the *British Aircraft Manufacturing Co.*, having side-by-side seats, a wooden semi-monocoque fuselages and a 175-hp *Salmson 9NG* engine.



**Above & Left: Cieva C.40 Autogiro**



**Left: caption: “Juan de la Cierva pilots his invention – the Autogiro, over the City of Valencia in 1934. The towers of the churches of Santa Catalina and San Lorenzo, and the Cathedral, with its bell tower are visible in the photograph.”**

**Above: a Spanish stamp commemorating Cierva’s flight <sup>366</sup> over *Valencia, Spain* in 1934**



**Above: on March 7<sup>th</sup> 1934, a *Cierva C.30* Autogiro piloted by *Juan de la Cierva* became the first rotary wing aircraft to take-off and land on the deck of a ship when it performed trials on board the Spanish Navy Seaplane Tender *Dedalo***



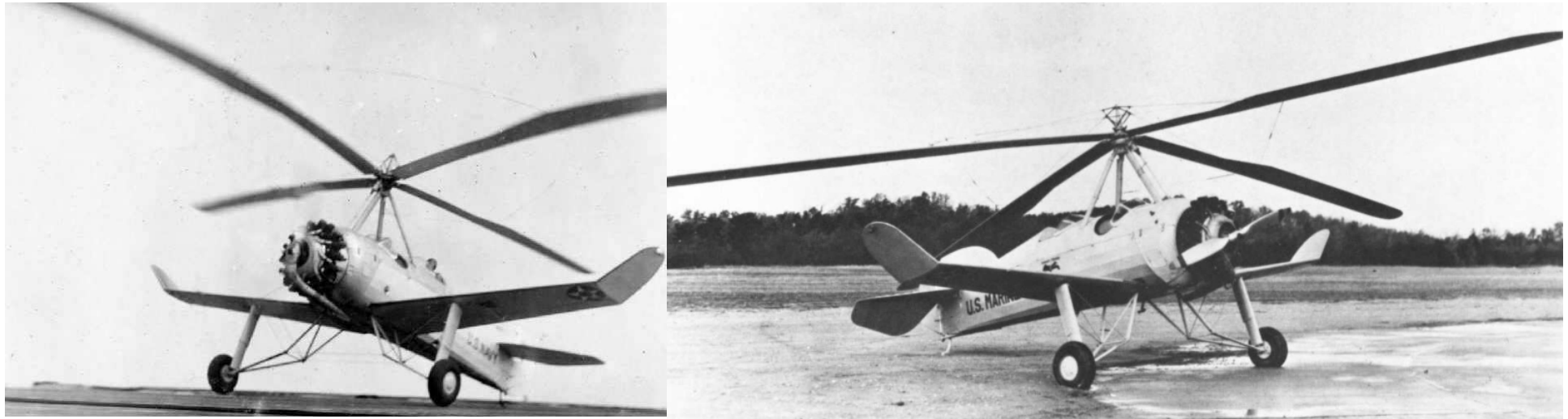

***“The Navy is very interested in the possibilities of the autogiro. We have ordered one so that experiments may be carried out toward determining its adaptability to naval needs. The ability of the autogiro to land within a limited space its ability to hover over one point should make it extremely useful for reconnaissance work over bad country where adequate landing fields do not exist. There can be no doubt but what the development of the autogiro is the outstanding achievement in aviation during the past year.”***

**Rear Admiral W.A. Moffett, Chief of the Bureau of Naval Aeronautics, USN**

**Left: caption: “A Pitcairn Autogiro in U.S. Navy markings takes off”**

368

**Right: caption: “U.S. Marine Corps PCA-2 under evaluation”**



**Above: caption: “Captain Kenneth Whiting, Commandant of Norfolk Naval Air Station, and pilot Lt. Alfred M. Pride are inspecting the new U.S. Navy Autogyro plane at Norfolk Naval Base - Norfolk, VA. It was purchased from the Pitcairn Aircraft Company.”**



The U.S. Navy's *XOZ-1* autogiro was a *Consolidated N2Y-1* tandem-seat biplane trainer rebuilt in the mid-1930s as an Autogiro. These planes were used as familiarization trainers for the Navy "skyhook" pilots who flew fighters from the large Navy airships *USS Akron* and *USS Macon*. The *XOZ-1* was modified to an Autogiro configuration by the *Pennsylvania Aircraft Syndicate*, with a four-bladed Autogiro rotor held aloft over the forward cockpit by four steel struts, replacing the upper wing. The lower wing was retained, supports added and the wheeled undercarriage was replaced by twin floats. The two-bladed wooden airscrew was retained as were the two open, tandem cockpits. The aircraft was tested by <sup>370</sup> the *National Advisory Committee for Aeronautics (NACA)*.

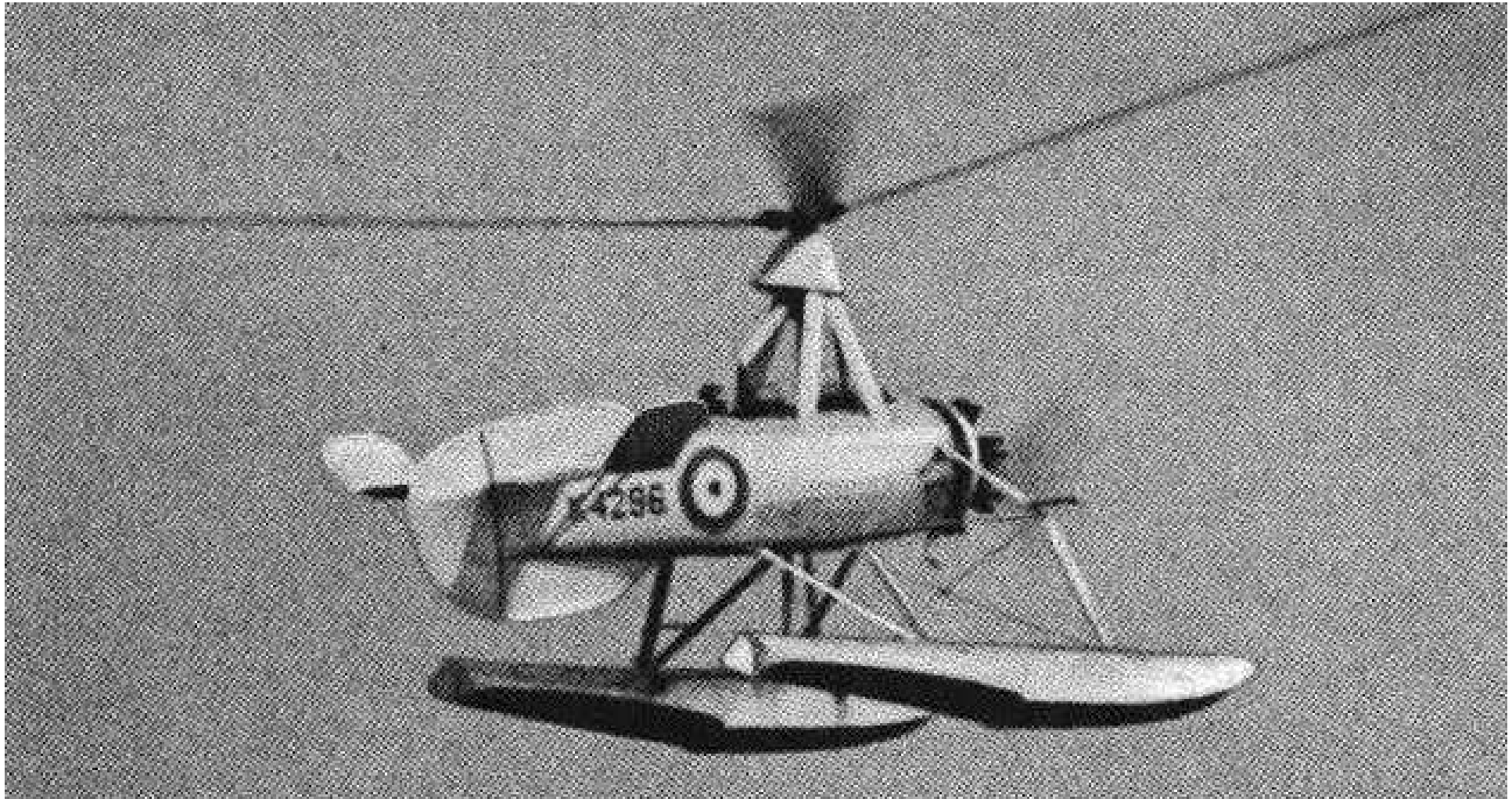

**One twin-float *Cierva C.30A* (above) designated “Sea Rota” and ten standard Rotas (with wheeled undercarriages) were completed to Specification 16/35 (1935)**

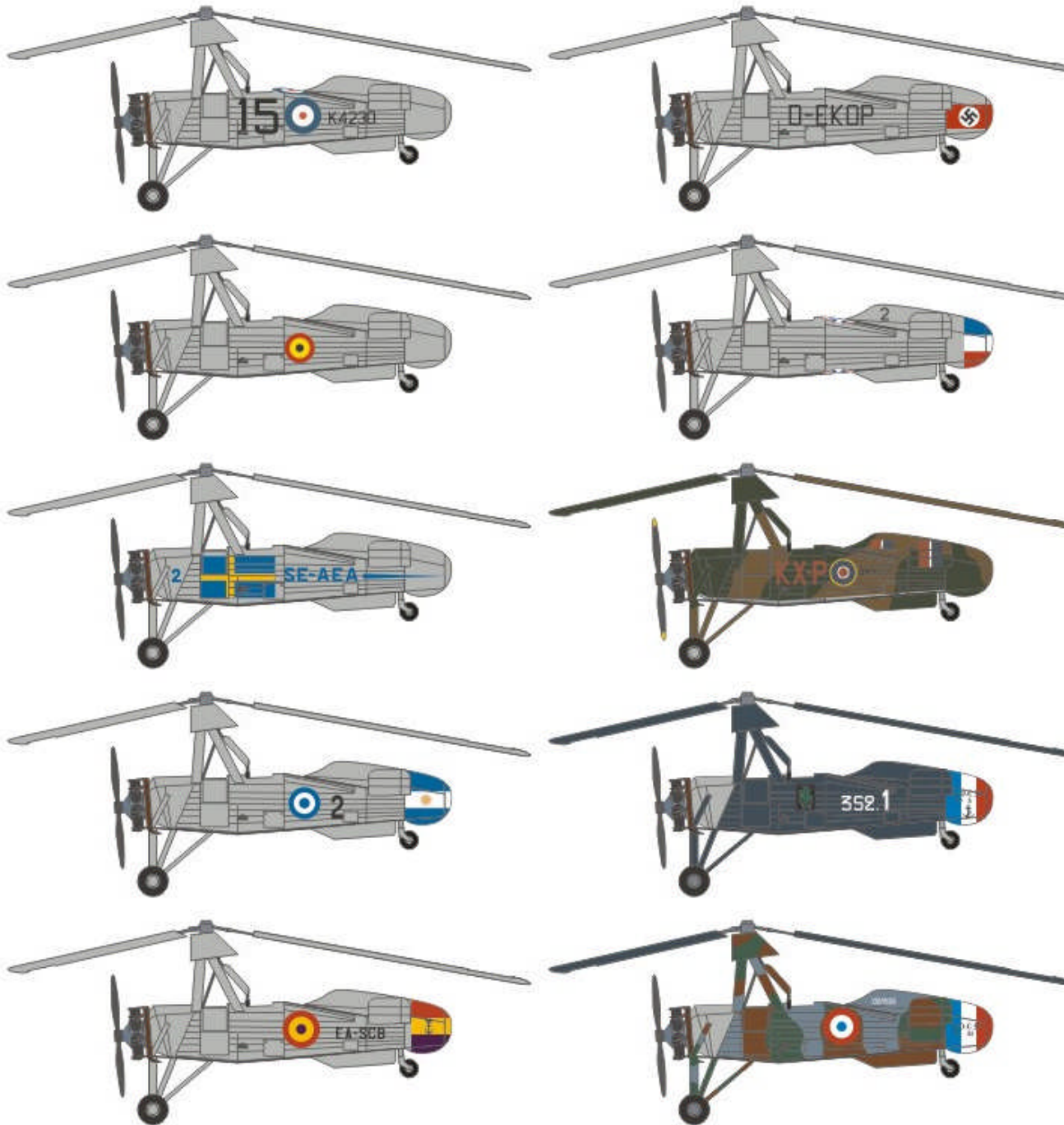

A total of thirty-seven C.30A's appeared on the pre-war British civil register, and others were completed for customers in *Europe, India, China, Australia* and *South Africa*.





At the outbreak of the *Spanish Civil War* (July 17<sup>th</sup> 1936 to April 1<sup>st</sup> 1939), *Juan de la Cierva* supported the forces of *Francisco Franco*, helping the rebels to obtain the *De Havilland DH-89* “Dragon Rapide” which flew General Franco from the *Canary Islands* to *Spanish Morocco*. During the war, his brother was executed by the Republican army.



Two of the original five Rota II's were diverted to civilian customers (replacements were built in 1938-39). In 1940, all available Cierva Autogiros and pilots went to *Duxford* where they later went to the RAF to form *529 Squadron*. They were used throughout the war for radar calibration. Whilst so engaged, one was intercepted by two FW 190s, the pilot cleverly managed to avoid both and landed safely at *Hawkings*. It's interesting to note that the RAF's *Cierva C.30A* Autogiros would daily calibrate the coastal radars that enabled the RAF to defeat the German *Luftwaffe* and win the *Battle of Britain*. All Autogiros were stood down in the UK in October 1945. The biggest user of Autogiros during WWII was *Japan*, using some of their twenty-four Autogiros for submarine spotting duty. Cierva Autogiros began building helicopters at the *Cunliffe Owens* factory at *Eastleigh* in 1943 - only seven miles from *Hamble* where the first production Autogiros were built. The example illustrated above is the former G-ACWP, rebuilt in 1962 and now in the possession of the *Science Museum, London*.





In 1932, Cierva moved to *Hanworth* where the ultimate Cierva design - the *C.30*, was built. With orders for one-hundred machines, it was highly successful with many being used for traffic control, news reporting, aerial surveying, motion pictures and military purposes. In December 1936, *Juan de la Cierva* was killed returning to *Spain* on a *KLM DC-2* which crashed on take-off at *Croydon*. Cierva's licenses were taken up in the UK by *Wier*, *Avro*, *Parnell*, *Westland* and *De Havilland*; In the U.S. by *Pitcairn* and *Kellett*; *Focke Wulf* in *Germany* and *Kayaba* in *Japan*.



***“Juan de la Cierva will be known to enduring fame as the outstanding pioneer in the field of rotary wing aircraft...All helicopters and similar types of craft that have shown promise of practical performance incorporate some of the principles and inventions developed by Cierva.”***

***Harold F. Oitcairn***

**RE: the importance of Cierva’s work on rotors and the effect upon the evolution of the helicopter is recognized throughout the aviation industry. In the process of creating the Autogiro, Cierva established an understanding of rotor dynamics and control, which was applicable to all rotorcraft and undoubtedly led to the realization of the helicopter. Technology developed for the Autogiro was utilized by experimenters in the development of the helicopter, the first fully successful example of which, the *Fw 61*, was flown in 1936 by *Cierva Autogiro Company* licensee *Focke-Achgelis*.**

When *Juan de la Cierva* was killed in a plane crash, he was only 41 years old. There were other people developing Autogiros, but Cierva had been one of the main driving forces behind the movement. Much was lost when he was killed. Another factor that kept the Autogiro from being accepted was purely psychological. Even though helicopters weren't successfully flown until 1935, they had been under development for as long as airplanes. The general public knew about helicopters and understood the principle of a powered rotor. Autogiros had an un-powered rotor that spun due to aerodynamic forces. Most people did not understand how it worked and so did not trust it. After helicopters flew successfully and the companies that designed and built them got military grants for further research, the Autogiro was essentially abandoned. Except for a few concepts and only a handful of attempts at civil designs, Autogiros were kept alive only as home built aircraft, and at that mostly as ultra-lights. Autogiros were the first successful rotary-wing aircraft to fly. They marked a departure from conventional fixed-wing aircraft and an attempt to fill a role that airplanes could not. They could fly slowly due to a phenomenon known as autorotation whereby the rotor is un-powered and is made to spin by aerodynamic forces (autorotation allowed the wings to move faster than the aircraft). Many technologies essential for practical helicopters were first developed for the Autogiro. If Juan de la Cierva had not pursued the Autogiro, it almost certainly would have delayed the development of the helicopter, maybe even for decades.



**In 1945, *Cierva Aircraft Company* was absorbed into *G&J Weir* and the resulting company was called *Weir-Cierva*. At that time, the only helicopter under development by Weir was the *W.9* (above). It was an experimental tandem design begun in 1944. Power was provided by a *de Havilland Gipsy Six Series II* engine with one main rotor and instead of an anti-torque tail rotor, it used a system of thrust reaction expelling air through an opening. Only one *W.9* was ever built.**

**Above: caption: “The Cierva W.9 used the push of a reactor to cancel torque reaction of the rotor”** 379



Before his death, Cierva's company had licensed his technology to Germany's *H.K.J. Focke*, which would lead to the *Fa-61*. Austria's *Raoul Hafner* was already developing the "spider system" in the 1935 *A.R. III Gyroplane in England* that would allow the Autogiro to morph into the helicopter. Cierva was certainly aware of these developments and, albeit it slowly, was moving in the direction of helicopter development as were significant personnel in his company. The Autogiro also led directly to the *Cierva C.38 Gyrodyne*, which utilized a powered rotor for hovering and low speed flight and a side-mounted propeller for torque correction and propulsion in cruise flight. As airspeed increased, propeller power increased while rotor power automatically decreased which reduced rotor collective pitch to autorotative angle with the rotor remaining parallel to the flight path. As airspeed reduced, propeller power decreased while rotor power automatically increased which increased rotor collective pitch to non-autorotative angles. The *Fairey FB-1 Gyrodyne* (above), first flown in December 1947, established the superiority of this configuration over that of the helicopter, which Cierva consistently rejected as too mechanically complicated, even though he<sup>380</sup> agreed with the requirement for hovering performance.



The designation *W.10* was assigned to a single engine helicopter project. The *W.11 Air Horse* (left) made its first flight in December 1948. At the time, it was the largest helicopter in the world. A single *Rolls-Royce Merlin 24* 1620-hp engine mounted on the fuselage powered three rotors projected from a square fuselage. It carried a three-person crew and had capacity for twenty-four seats, but was planned for other tasks such as ambulance, crane and to spray crops (it could carry a payload of +3K kilograms of insecticide). For the latter task it held great promise. Unfortunately, it crashed on June 13<sup>th</sup> 1950 killing all three crewmen. A second prototype never flew and was scrapped in 1960.

***“...we can ask the question of why autogyros were never widely accepted. Just about every aviation historian has their own answers to this question, but here is this author’s opinion. Early autogyros, although they had a higher speed envelope than airplanes, had a higher drag and so were not as efficient at higher speeds, and absolutely could not attain the maximum speeds of the faster airplanes. Also, the early autogyros did not have the vertical takeoff and landing capabilities that would have made them more attractive to potential buyers. When the C.30 finally demonstrated a successful jump takeoff in 1934, it was less than a year until the first successful helicopter flew, and only a few more years until the very successful Sikorsky VS-300 and VS-316. Although helicopters had a smaller speed envelope than autogyros, they were capable of hovering, and their envelope could fill the role that airplanes couldn’t. In other words, anything an autogyro could do could be done by another aircraft. Also, Cierva, who was doing most of the development of autogyros, was funding much of the development on his own. When the army ordered the VS-316, that money went in to Sikorsky’s company. This gave Sikorsky the funding for development that Cierva was running out of. Without the money, Cierva just couldn’t fund the research. And then, on December 9, 1936, Cierva was killed in a plane crash (a DC-2 operated by KLM). He was only 41 years old. There were other people developing autogyros, but Cierva had been one of the main driving forces behind the movement. Much was lost when he was killed.”***

***Jeff Lewis, Author***



***“Where and whenever the pioneers of aviation are celebrated, Juan de la Cierva’s name is enshrined. He is one of the few in history of whom it can be said that what he had envisioned changed the world.”***

**Rear Admiral William A. Moffett, Chief of the *Bureau of Naval Aeronautics, USN***

**Above: caption: “Juan de la Cierva in command of his C.4 Autogiro in its first successful flight (January 1923)”**



# FIRST AUSTRALIAN AUTOGIRO FLIGHT



*Melbourne to Portland, 16th November, 1934*

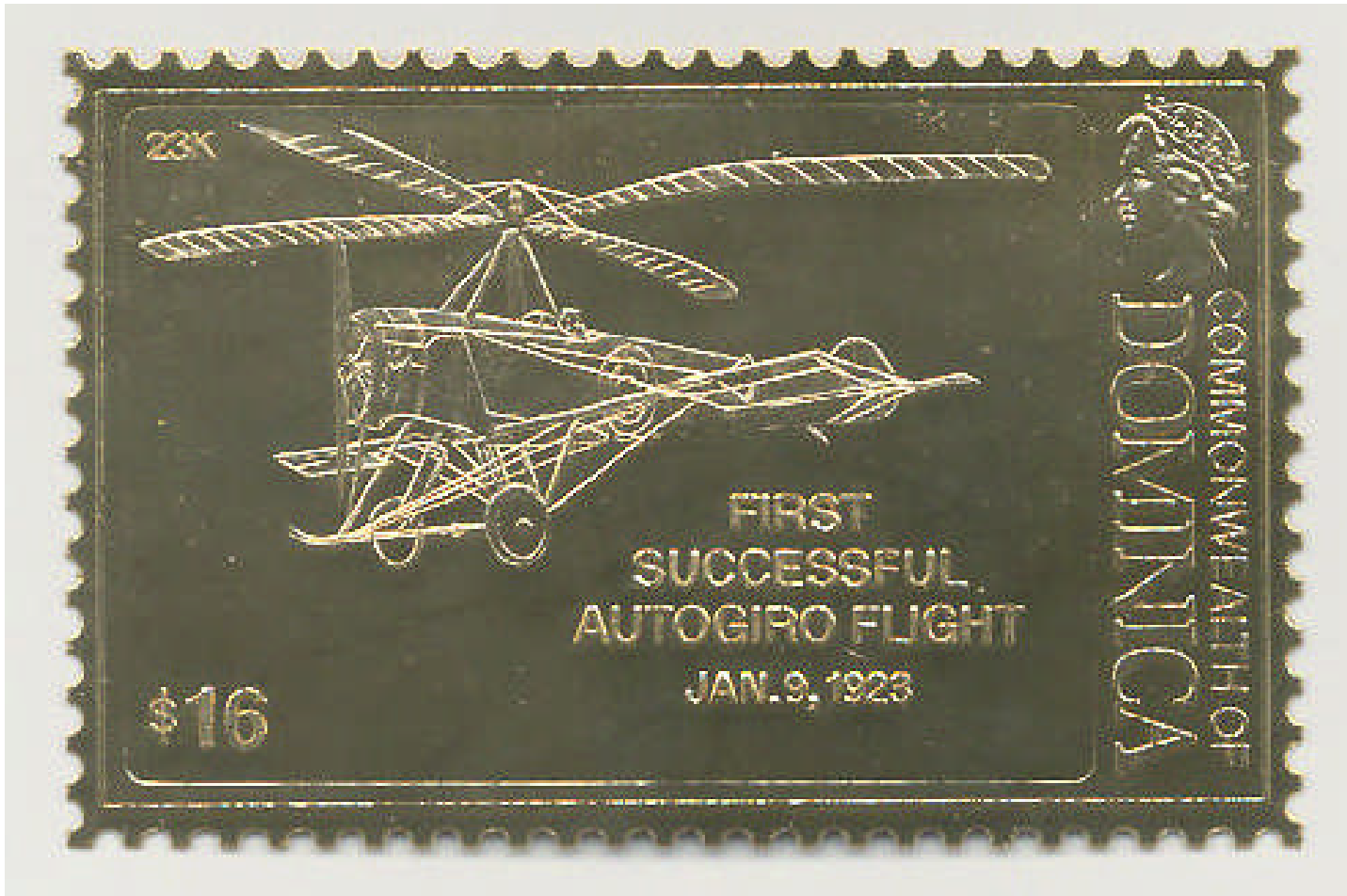



**Above & Left: the memorial monument to Spanish engineer and aviation pioneer *Juan de la Cierva*, in the town of *Mucia, Spain*, where he was born on September 21<sup>st</sup> 1895. It was created by the sculptor *Francisco Toledo***



# Part 5

# The American Autogiro

**That's the Answer**



**Above: caption: “Pitcairn chief pilot James G. Ray with Thomas A. Edison standing in front of the Pitcairn PCA-2 Autogiro in 1930. Edison, who had unsuccessfully attempted to develop a rotary-wing aircraft, is reported to have proclaimed, upon seeing the Autogiro fly, ‘That’s the answer, 390 that’s the answer.’”**



During the 1930s, some five-hundred Autogiros were built around the world. In *Great Britain*, the *A.V. Roe, de Havilland, Weir* and *Westland Company/s* produced them. In *Germany*, *Focke-Wulf*, in *France*, the *Loire Company*, in *Russia*, *The Central Aerohydrodynamic Institute (TsAGI)* and in *Japan*, the *Kayaba Company*. In 1928, *Harold Pitcairn*, who had been involved with aviation in the *United States* since 1914, negotiated successfully with Cierva and in February 1929, Pitcairn purchased the U.S. rights to Cierva's inventions and the Autogiro patents then existing and established the *Pitcairn-Cierva Autogiro Company* for licensing its manufacture in the *United States*.

Top: *Juan de la Cierva* (left) and *Harold Pitcairn* (right) astride a *Cierva C.8 Autogiro* (ca. 1929)

Left: *Juan de la Cierva* and *Harold Pitcairn* pose for the camera. Both men were destined to die tragically.



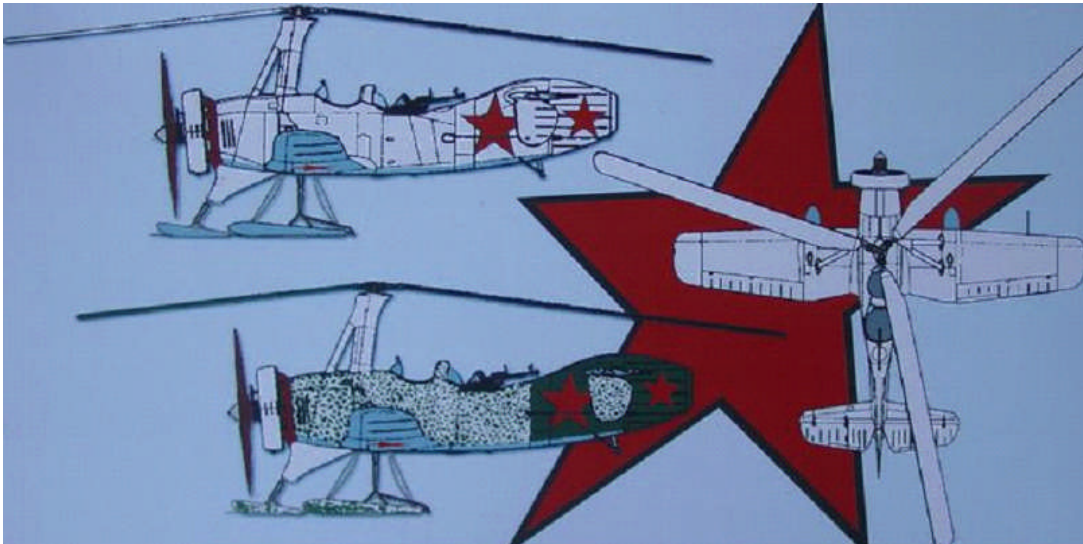

**Top Right: Kamov KA-SKR2 Soviet Cierva Autogiro (1930)**

**Top Left: winter ski version of the Russian TsAGI A7 Autogiro. Since it was not built under a Cierva license, it was not officially an Autogiro. It was the first such aircraft specifically constructed for combat operations, but faded to obscurity in the early days of WWII.**

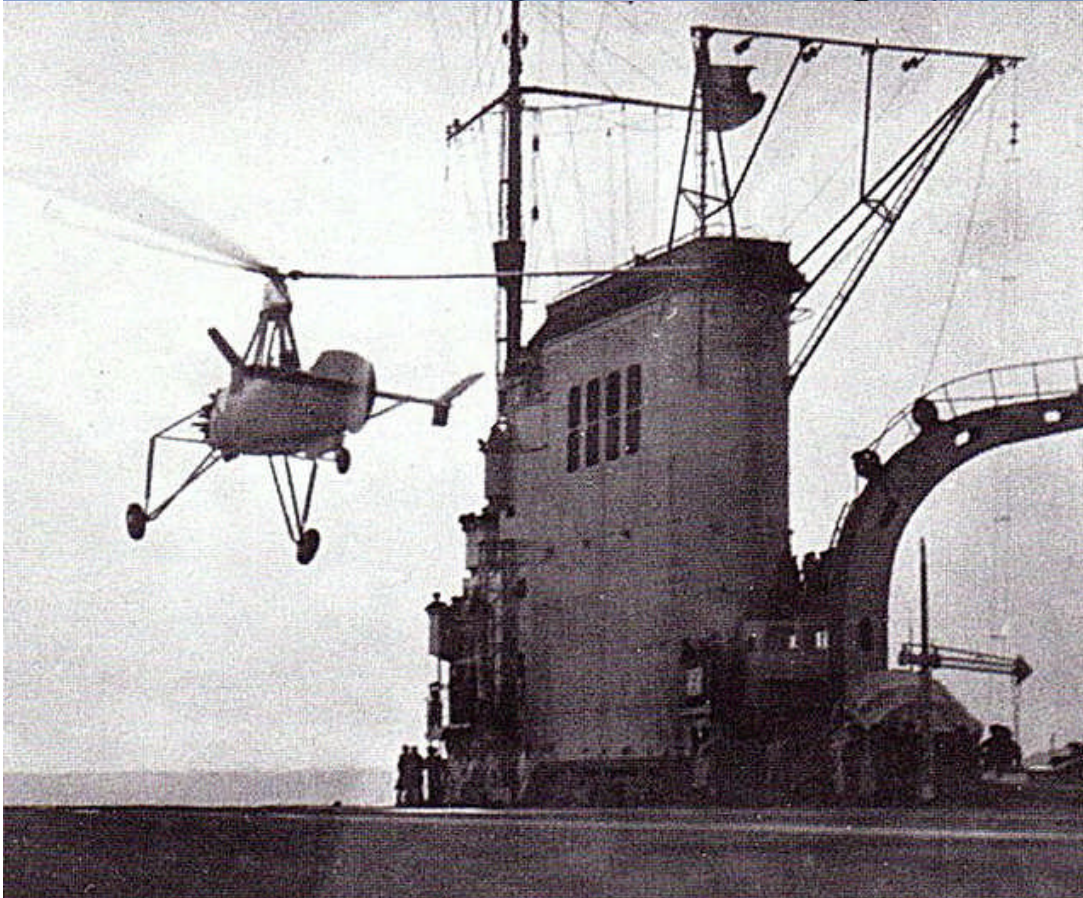

**Left: Liore et Olivier LeO Cierva C.30 Autogiro landing on a French naval vessel**



In order to finance the *Pitcairn-Cierva Autogiro (PCA) Company*, *Harold Pitcairn* sold all of Pitcairn Aviation's valuable airmail routes. This gave Pitcairn the necessary capital to further develop the Autogiro and, in fact, the first licensee of the PCA was *Pitcairn Aviation*. In 1929, the first Pitcairn Autogiro; the *PCA-1*, flew. The *PCA-1* was followed by the *PCA-1A* and the *PCA-1B*, both experimental models based on Pitcairn's fixed-wing *Mailwing* designs. An improved version; the *PCA-2*, followed in 1930.

Above: Pitcairn Aviation's *PA-7A Sport Mailwing* (1929)

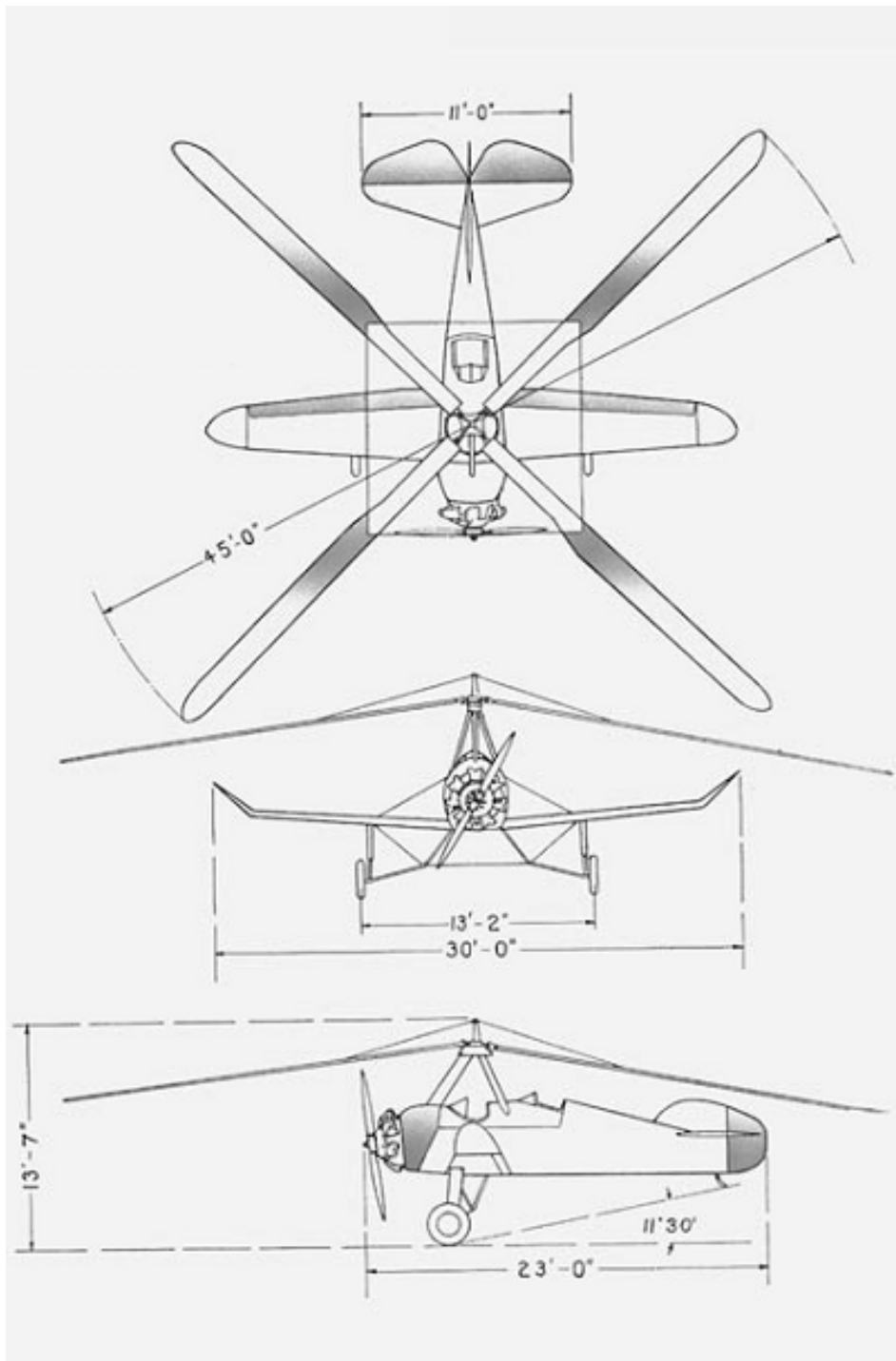

The *Pitcairn PCA-2* (left) was the first original American Autogyro design and featured a pre-rotator. The pre-rotator used a clutch to rotate the rotor head via the engine while on the ground. This was a major advancement that eliminated the need for ground taxiing to get the head up to speed for take-off. *Juan de la Cierva* promptly incorporated a similar feature in his later designs. It was in 1931, flying in a Pitcairn PCA-2, that *Amelia Earhart* set a world altitude record for Autogiros. This flight brought significant attention to Pitcairn and the Autogyro (as did her transcontinental *Beech-Nut* tour/s). In April 1931, the PCA-2 became the first rotary-winged aircraft certified for commercial use in the U.S.

Left: plan/elevation views of the Pitcairn PCA-2



Twenty-four PCA-2's were built for the *U.S. Navy* and *Fairchild* soon imported a *PCA-2* as the first rotary-winged aircraft registered in *Canada*. A *PCA-2* was used by the *Standard Oil Company of New York* for testing until it was sold to the *Sealed Products Corporation*. This company used it for tests and for advertising. In 1932, it flew 96K km to visit 225 cities in twenty-two states and *Mexico* to promote the company's products. The *PCA-3* (1931) used a *Pratt & Whitney WASP Junior* engine and a 48-foot rotor (only one was built). In 1936 the *AC-35 "Roadable"* hybrid Autogiro was introduced.

Left: Pennzoil's "Transcontinental (PCA-2) Autogiro." It was flown cross-country in May and June 1931. At the 1932 *National Air Races* in *Cleveland*, it was struck by another plane and damaged, but was repaired.

Right: Standard Oil of Ohio's (SOHIO) Autogiro





**Left:** this beautiful photograph was taken in August 1932 when the *Coca-Cola* Autogiro took a world-renowned astronomer 4K-feet in the air to witness an eclipse of the sun from above the clouds, giving him a “perfect view.” The astronomer actually closed his eyes ten minutes before the eclipse became total and then, upon a signal from the pilot, opened his eyes to receive the most complete impression and began his calculations. The Coca-Cola Company’s Autogiro was used by the advertising department to promote the six-pack package to dealers of Coca-Cola. In addition to guiding the Autogiro “with consummate skill, despite the darkness,” the pilot, *William Campbell*, simultaneously held a thermograph, which registered the drop in temperature (about eight degrees) during the eclipse. In 1934, the Coca Cola Autogiro was presented to *Georgia Tech* for the study of aeronautical engineering.



**Above: Earl Eckel received three Autogiro pilot licenses (private, industrial and transport) in 1932 and in the same year secured a contract from the *Tidewater Oil Company* to conduct a promotional tour of the southern states for its product *Veedol*. This five state tour, which included guest rides, parades and musical programs at each stop, was followed by another tour of *New York* and the *New England* states the following year. Eckel calculated that he carried over 4K guest passengers during his promotional work for Tidewater and made over 800 take-offs and landings without incident. Other activities included student instruction, banner towing, and carrying air mail from his airfield to *Newark, NJ* during *National Air Week* in 1938. He gained renown for his mastery of Autogiro flying performing difficult stunts and maneuvers at air shows including the loop, hammerhead stall and hover descents and landings. "Eckel's Autogiro Port" in *Pleasant Valley, NJ* included a runway with flood and boundary lights and two small hangars. <sup>398</sup> It was the first airfield built exclusively for Autogiros.**





# High Point

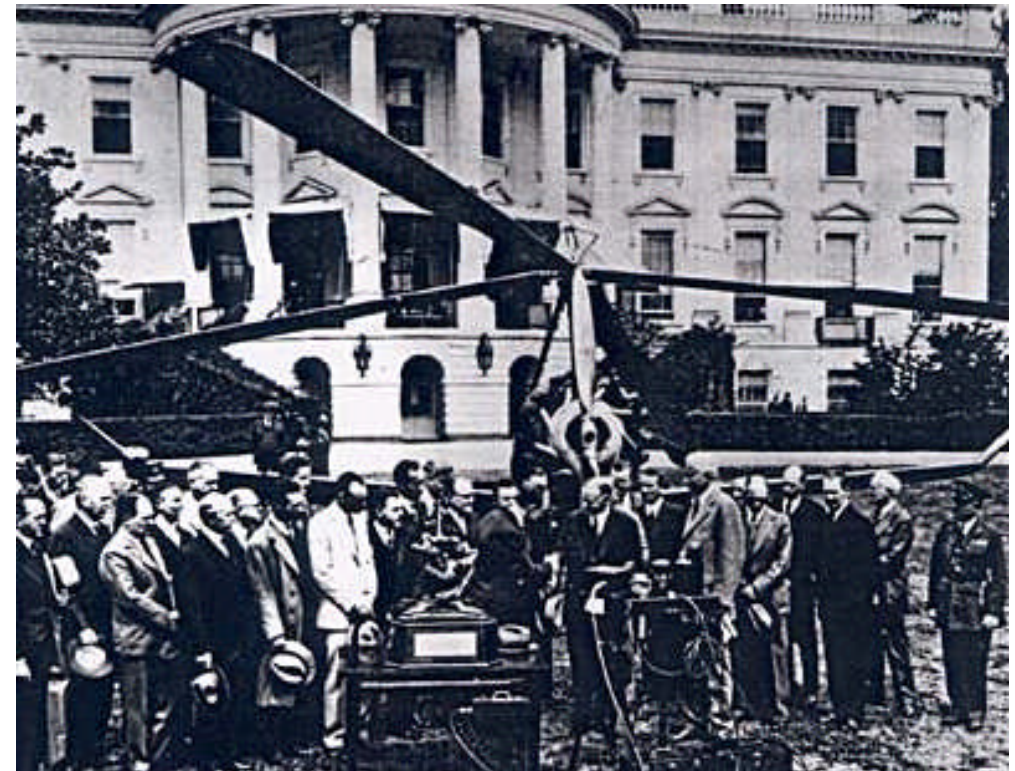

For developing the Autogiro, *Harold Pitcairn* and his associates received the prestigious *Collier Trophy* (left) from POTUS *Herbert Hoover* in 1931. The trophy was awarded for the most significant aviation contribution in the preceding year (1930). The ceremony took place on the *White House* lawn where a *PCA-2* was landed for the event (above). This was the first rotary-wing aircraft to land at the White House.



Although *Harold Pitcairn* had wanted the ceremony at a time convenient for *Juan de la Cierva* to attend, it was President Hoover's schedule that dictated the timing of the ceremony which occurred on April 22<sup>nd</sup> 1931 at the *White House*. Hoover, previously Secretary of Commerce under President Coolidge, had worked with Pitcairn in committees that had drafted aeronautical safety regulations and he followed the development of the Autogiro studiously. He was keen to see an Autogiro and personally requested that the ceremony be held on the south lawn of the *White House* so that an aircraft could land and provide a public demonstration of its unique flying capabilities. It was a publicity triumph and Pitcairn made the most of it as that was, in many ways, the most significant moment in the development of the Autogiro in the *United States*



**HAROLD F. PITCAIRN**  
The noted aeronautical pioneer established his first flying field on this site in 1924. The 1930 Collier Trophy, an award for accomplishments in aviation, was presented to Pitcairn and his associates for developing the American autogiro, first introduced here.



**Harold Pitcairn** had reason to be optimistic about 1931. In December 1930, *Juan de la Cierva* had published a well-received article entitled “Uses and Possibilities of the Autogiro” in the *Aero Digest* magazine. Advertising for the Autogiro and the *PCA-2* was just beginning and the public response was overwhelmingly positive. In March 1931 when *David S. Ingalls*, the Navy’s only WWI ace and Assistant Secretary of the Navy, published an article in *Fortune* magazine entitled “Autogiros – Missing Link” asserting that “Inventor Cierva and Impresario Pitcairn offer the most promising new flying machine in the thirty-year history of aviation.” It was heady praise indeed, bolstered by the news that Pitcairn and his associates has been awarded the prestigious *Collier Trophy* for the greatest achievement in American aviation for 1930.

Left: *Harold Pitcairn* in front of his personal Autogiro (ca. 1929) 404

# **The Autogiro Company of America**

***“The Autogiro Company of America is an engineering and licensing organization. It owns and controls, exclusively, all Autogiro patent rights in the United States. Manufacturing companies of high standing will be licensed to build Autogiros with the full cooperation of our engineering staff. Present licensees are: Buhl Aircraft Company, St. Clair, Mich...Kellett Aircraft Corp.,\* Philadelphia, Pa...Pittcairn Aircraft, Inc.,\* Willow Grove, Pa...F.W. Serete Company, Bar Building, White Plains, N.Y. \*Now in production”***

**RE: excerpt from a 1932 Autogiro Company of America (ACA) advertisement appearing in *TIME* magazine**

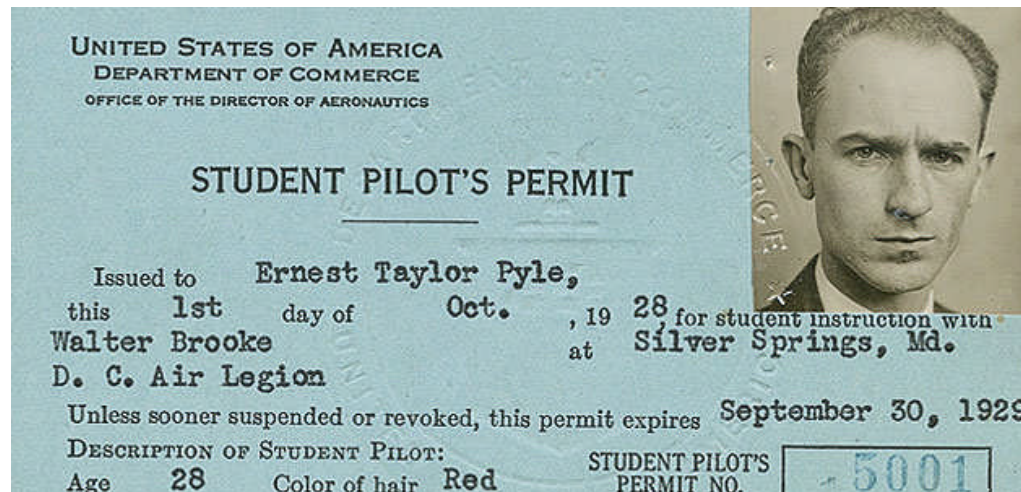

Pitcairn's intent was to fan the public fires of Autogiro interest and he set about the task with creative ingenuity. He arranged for journalists to take rides in the *PCA-2* and then used their columns in advertising to tout the revolutionary nature of Autogiro flight. *Ernie Pyle* had become the aviation editor for the *Washington Daily News* in March 1928. Pitcairn arranged for *Jim Ray* to take Pyle for a ride and the newsman, in turn, praised the Autogiro's performance in a column dated September 26<sup>th</sup> 1930. Pyle, who would go on to fame as a combat journalist in WWII before his death on the island of *Le Shima* (off the coast of *Okinawa*) on April 18<sup>th</sup> 1945, quoted a flying companion as exclaiming "That's the kind of plane for you and me, Ernie, one that comes straight down and slow. That expresses the whole thing. It's a great piece of machinery."

Above: Ernie Pyle's student pilot permit dated October 19<sup>th</sup> 1928. Although he had a student permit, he never earned a pilot's license. Pyle wrote about aerial mapping, the perils of night flying, airline safety and engine and airplane design and profiled crop-dusters, glider pilots, military aviators, parachutists and barnstormers. Based in *Washington, D.C.*, Pyle regularly visited nearby *Hoover* and *Bolling Fields*, the *Washington Naval Air Station* and a handful of smaller airfields.



# What can the AUTOGIRO do ?



(Reprinted from Washington News, Sept. 26, 1930)  
**HOW A FLIGHT IN THE FAMOUS AUTOGIRO FEELS**  
*Ernie Pyle—Aviation Editor*

in a marvelous machine. Understanding very little of aerodynamics and engineering principles I cannot attempt to pass judgment on Autogiro's worthiness. I can only try to describe the sensations of flying in it.

Down from Washington-Hoover Airport, Ray took his brakes, threw in the clutch, started the motor, and the big paddles started flapping. In a few seconds they were going and so rapidly you could hardly see them. It swifter than I had always thought.

As he released the brakes, the plane ran a few feet, and was off the ground. The sensation of climbing in the Autogiro is much the same as in a regular airplane, except that you get up altitude fast without realizing it. It is like a zoom.

As I made one climb, turning around the field, hardly outside the boundaries of the field, twice over a thousand feet high. On an altitude of 2000, with the air speed very slow, what would have been the ceiling point in other planes.

There was very little wind. Jim headed into it. Instead there was, thumped the motor on to about 900 rpm, and there we sat, half asleep on the airport. I guess we were going down slowly, and I am sure we were settling forward, but our sight was such that there is no sensation of motion whatever. We had suspended there.

As we made some turns, the Autogiro's sails as it turned up at the end, to keep it from falling on the turns. It seemed that Jim was taking that wing-tip into some delicate but visible hole in the air, and that we were slowly swinging around it.

Finally we started our glide into the field. I see they will have to coin a new word for Autogiro's glide, for it certainly isn't that. It is the better word.

As I wing forward so slowly that you could fully see the winter past objects on the ground, it seemed that we were settling very rapidly. Very much like going down in an elevator.

As we a few feet from the earth, he threatened to yank the stick clear back, and we settled to earth with hardly a bump at all. It rolled a few feet and stopped.

As I made two flights in the Autogiro, and after about 20 minutes. When I climbed it, Bill Sommerer said: "That's the kind of chair for you and me, Ernie, one that comes right down and slow." That expresses the whole thing. It's a great piece of machinery.



**A**N AUTOGIRO can fly well over 100 miles per hour but, unlike any other heavier-than-air craft, it does not depend upon speed for security.

It sustains itself at unheard of low speeds, it can even stop all forward speed and hover momentarily in the air or descend vertically, more slowly than a man in a parachute.

With a dead engine, it can glide to a landing, or descend vertically and gently to a selected spot beneath it.

It can take off with almost no run on the ground and at very low speed; can climb at an angle steeper than any airplane. . . . It can bank and turn slowly without fear of loss of forward speed. . . . It cannot fall off into a spin from a stall. . . . It can land in almost any clear open space. . . . Any experienced pilot can fly it with but a few minutes of ground instruction.

Thomas Cartoll, in the December 1930 Aero Digest, estimates that personal security in the Autogiro is governed 90% by the inherent

stability of the machine and only 10% piloting skill—this as opposed to 90% and 10% inherent stability in the conventional airplane. Mr. Cartoll is one of this country's best known test pilots and was for ten years with the National Advisory Committee on Aeronautics. We are confident that Autogiro points toward the possibility that the average person can consider the operation of an aircraft with assurance comparable that experienced with the automobile.

The Autogiro Company of America is not a manufacturing or selling company. It is an engineering and licensing organization owns and controls, exclusively, all Autogiro patent rights in the United States. Manufacturing companies of high standing will be licensed to build Autogiros with the full operation of our engineering staff.

Present licensees are:  
 Buhl Aircraft Company, Detroit, Mich.  
 Kellett Aircraft Corp., Philadelphia, Pa.  
 Pittsirn Aircraft, Inc., Willow Grove, Pa.



**Left: adjoining this Autogiro Company of America magazine advertisement (right), on the left hand side is a column dated September 26<sup>th</sup> 1930 entitled: “What Can an AUTOGIRO do? – How a Flight in the Famous Autogiro Feels - Ernie Pyle, Aviation editor”**

In 1932, Pitcairn and Cierva shared the *John Scott Award*, presented by the directors of *City Trusts of the City of Philadelphia* for “the invention of the Autogiro, its improvement and development as a propelling and stabilizing force for heavier-than-air craft, and its introduction into America.” Pitcairn and Cierva began to work closely on Autogiro development, both traveling across the *Atlantic* to see the other. Cierva devised a control system that would eliminate the need for the fixed-wing control surfaces that were being used on the original indirect control Autogiros. Although the Autogiro was able to generate lift at slow speeds, the control surfaces did not function well and loss of control had led to several highly publicized accidents. Cierva correctly reasoned that, if he could make the rotor head directly control the aircraft, the fixed-wing control surfaces would not be needed and control would not be degraded at slow speeds. Cierva was proposing the cyclic control that is found in modern helicopters. The new type of Autogiro would be called a direct control Autogiro. Cierva also realized that through the use of Pitcairn’s pre-rotator system the rotor head could be over spun to store energy that could be used to affect a jump take-off. In order to convert this energy to lift, the pitch of the rotor blades needed to be collectively increased. This would cause the Autogiro to lift vertically into the air. De-clutching the rotor head and engaging the propeller would allow the Autogiro to fly forward, in effect performing a vertical take-off. This revelation significantly contributed to the collective control found in modern helicopters. Cierva shared his ideas with Pitcairn and the two worked to turn these ideas into reality.

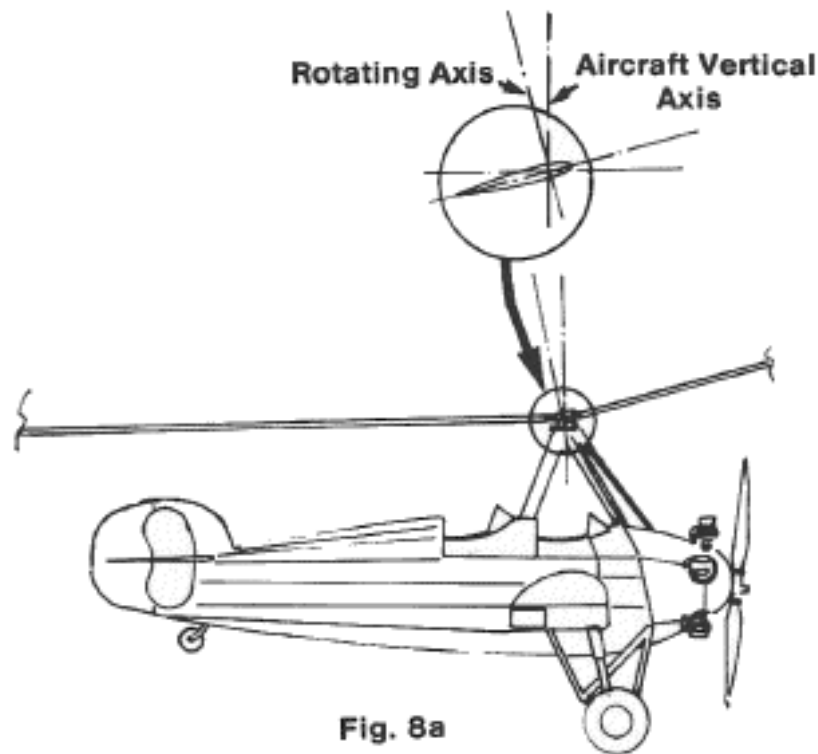

Fig. 8a

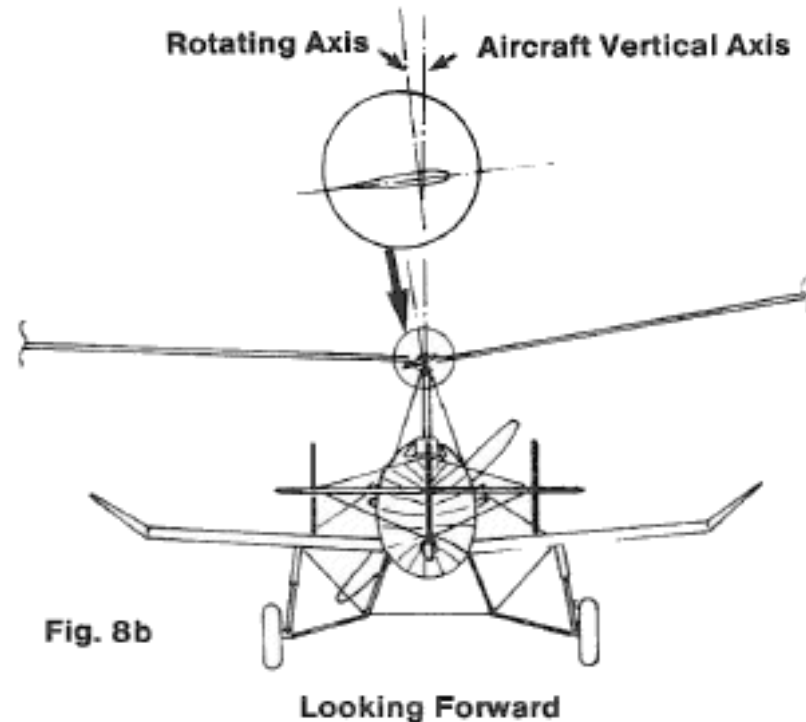
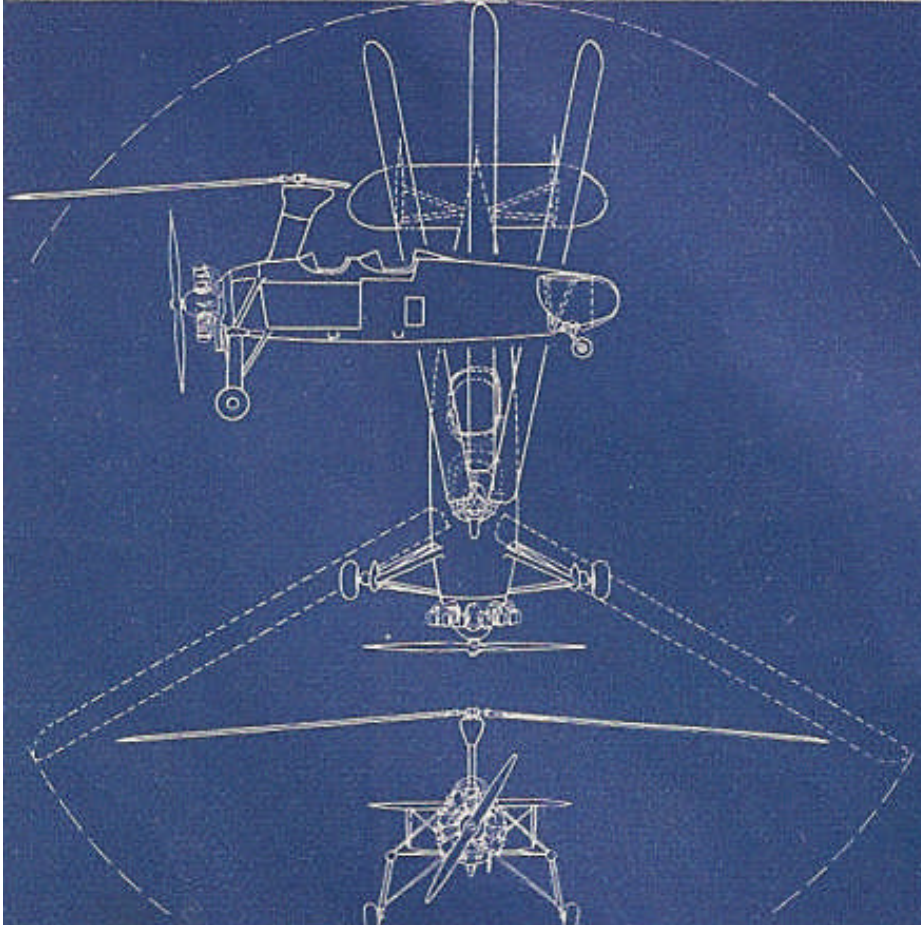
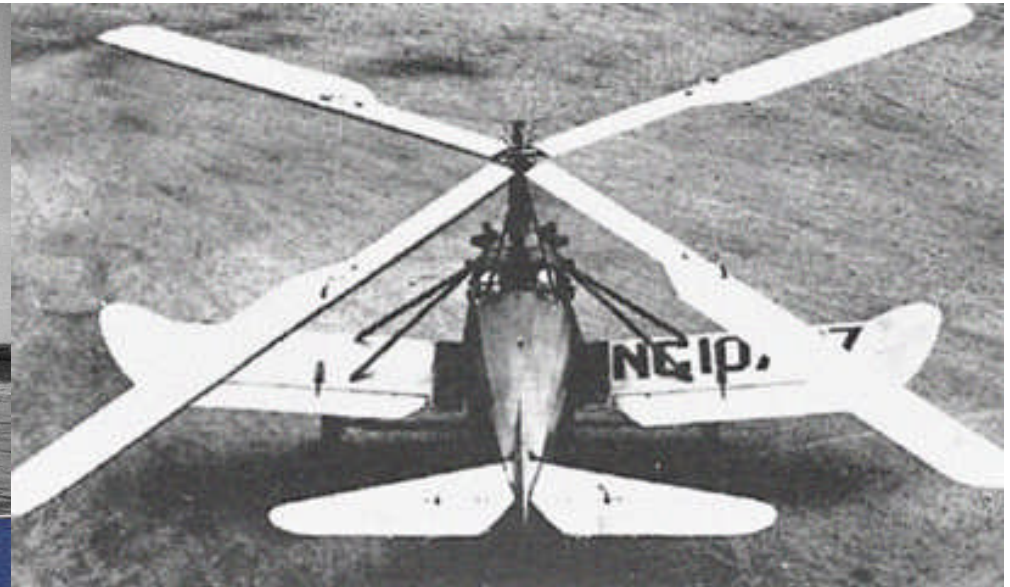

Fig. 8b

Looking Forward

In 1931, Pitcairn changed the name of the *Pitcairn-Cierva Autogiro Company* to the *Autogiro Company of America* (ACA). The ACA issued Autogiro manufacturing licenses to the *Buhl Aircraft Company* and the *Kellett Aircraft Corporation*; the later would build several Autogiros for the *U.S. Army*. On the Autogiros produced by Pitcairn and Kellett, the rotating mast of the rotor was inclined toward the retreating side and also inclined toward the rear, in that way “encouraging” the blades to flap (fig. 8-a & 8-b, above). To compensate for the differences in lift caused by this offset when the Autogiro was descending vertically, a lead weight was bolted inside the tip of the right wing.



Formed in 1929, Kellett's first autogiro was the two-seat *K-2* (above) of 1931, but its best-known design was the *KD-1* (top left) which first appeared late in 1934. Using the experience gained in building Cierva Autogiros under license, Kellett developed the *KD-1* which was similar to the contemporary *Cierva C.30* (the "D" denoted direct control). It had two open cockpits, a fixed tail-wheel landing gear and was powered by a 225-hp *Jacobs L-4* radial engine. After testing of the prototype, a commercial variant designated the *KD-1A* (left) was put into production. The *KD-1A* had a three-bladed rotor with folding blades and a number of minor detail improvements. <sup>411</sup>



***“The first cabin autogiro to be manufactured in the United States has been announced by the Kellett Aircraft Corporation of Philadelphia. The cabin has been developed to afford comfortable winter flying and protection from noise and wind. For flying in warm weather the cabin enclosure may be removed to convert the ship into a conventional open model. The cabin is made easily accessible by a door which opens up a portion of the roof on the right side...The Kellett cabin provides comfortable accommodations for two people seated side by side...Two distinct features of the Kellett design are a larger fixed wing than ordinarily used and a unique rotor pylon, in which a large diameter front member carries all of the starting and braking torque and most of the lift but no side load...”***

***Aero Digest, 1932***

412

***Above:*** caption: “The new American Kellett autogiro with removable cabin enclosure for winter flying”

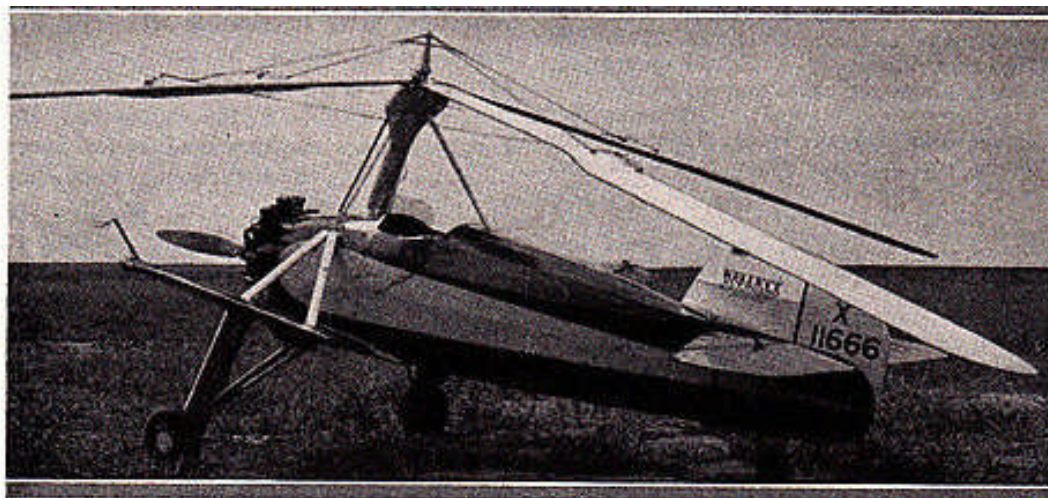

## Kellett K-4 Autogiro

• POWERED WITH the 210-horsepower Continental R-670 engine, the Kellett K-4 autogiro features a number of improvements over previous models in appearance, performance and structure. Reduction of the fixed wing area has provided greater visibility downward and improved the flying qualities. The new type undercarriage is entirely strut-braced and provided with streamline fairing. The cockpit has been enlarged and doors provided on either side, assuring easy access. The pylon structure is entirely faired and the pylon system reduced to two vertical members supported on either side by streamlined wires. A steerable tail wheel increases ground maneuverability. The K-4 is of the side-by-side open cockpit type, but a demountable cabin top can be furnished.

Other features include: Mechanical fuel pump with hand wobble pump for emergency use; Heywood type com-

pressed air starter; cockpit primer; demountable dual controls; metal propeller; low pressure tires with wheel brakes; parking brakes; oildraulic shock absorbers on undercarriage and tail wheel; fire extinguisher; navigation lights; padded and spring upholstery, and Friese type ailerons.

### Specifications

Gross weight .....	2400 pounds
Useful load .....	780 pounds
Length .....	19 feet 11 inches
Span .....	24 feet 7 inches
Wing area.....	63 square feet
Height .....	12 feet 3 inches
Rotor diameter .....	40.6 feet
Blade area .....	120 square feet
Disc area .....	1295 square feet
Gasoline capacity .....	45 gallons
Oil capacity .....	5 gallons
Cruising speed .....	93 miles per hour
Top speed .....	114 miles per hour
Cruising range .....	3.5 hours
Rate of climb, full load..	940 feet per minute
Ceiling .....	14,000 feet
Service ceiling .....	12,500 feet



**Above L&R: the *Kellett KD-1B* (which was a *KD-1A* with an enclosed cockpit for the pilot) was operated by *Eastern Airlines* and inaugurated the first scheduled rotary-wing air-mail service on July 6<sup>th</sup> 1939. A route was flown between the *Camden, NJ* airport and the roof of the *Post Office Building* in downtown *Philadelphia*. After one of the *KD-1B*'s fell into the street below, service was discontinued. Though it lasted for only a year, it was considered a success.**

## Crossing a New Frontier



THE AIR MAIL SERVICE FLIES A KELLETT AUTOGIRO TO THE ROOF OF PHILADELPHIA'S POST OFFICE

### We Congratulate . . . . .

The United States Postal Authorities, who are pioneering a dramatic method of speeding the air mail from airport to distributing center.

Eastern Air Lines, Inc., contractors for the world's first autogiro air mail route, who again contribute to aviation progress, public service and aeronautical safety.

And, with pardonable

pride, we point out that a Kellett wingless autogiro was chosen to bring scheduled air service to the heart of a modern metropolis; an aeronautical precedent to rank with spanning continents and oceans.

Advanced military designs and increased civil use of autogiros for transport, private commuting and the air mail service in other cities are logical developments of this new Kellett success.



## KELLETT AUTOGIRO CORPORATION

Constructors of Military and Commercial Autogiros Manufacturers of Aircraft Parts

PHILADELPHIA, PA.

AVIATION  
August, 1939

35

**“We Congratulate...The United States Postal Authorities, who are pioneering a dramatic method of speeding the air mail from airport to distributing center. Eastern Air Lines, Inc., contractors for the world’s first autogiro air mail route, who again contribute to aviation progress, public service and aeronautical safety. And, with pardonable pride, we point out that a Kellett wingless autogiro was chosen to bring scheduled air service to the heart of a modern metropolis; an aeronautical precedent to rank with spanning continents and oceans. Advanced military designs and increased civil use of autogiros for transport, private commuting and the air mail service in other cities are logical developments of this new Kellett success.”**

RE: excerpt (highlighted) from 1939 advertisement for the *Kellett Autogiro Corporation*. 415



and Air. Dedicated May 25, 1935.

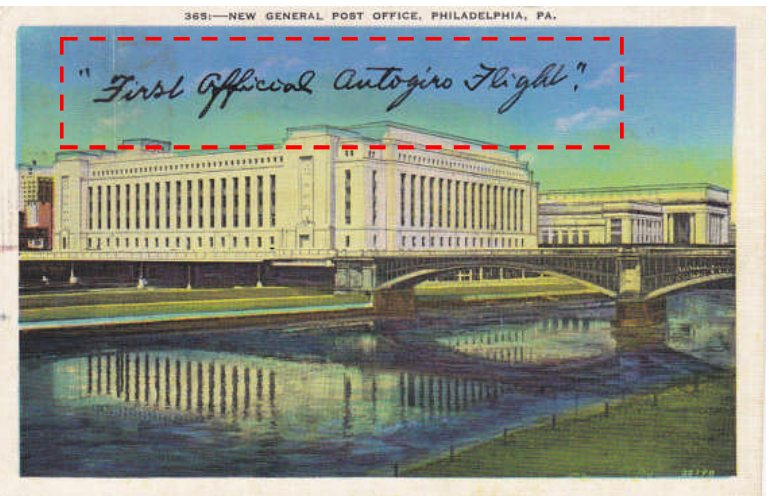

Above: postcard from 1939, showing view of the new *General Post Office* in *Philadelphia, PA* with “First Official Autogiro Flight” in script across top

Left: “First Flight - United States Air Mail - Rotary-Wing Aircraft- Philadelphia, PA - Camden Airport, NJ - Experimental Route 2001” (stamp on back of postcard)

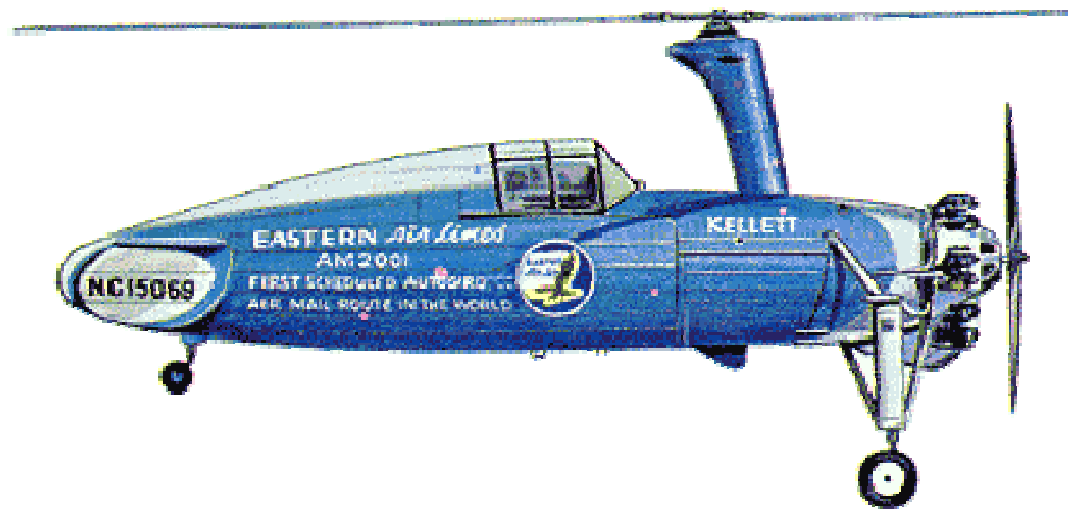
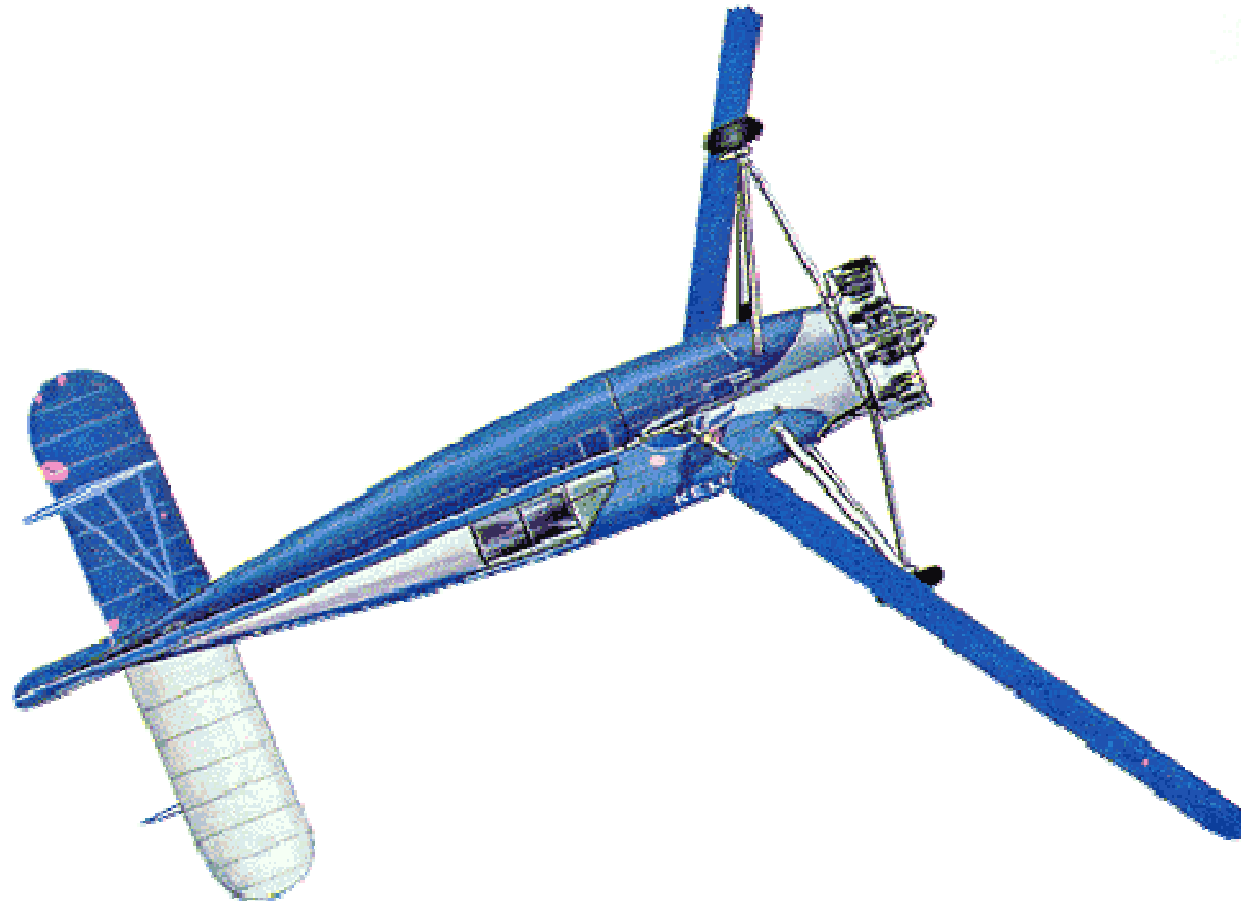



# Rooftop Giroports

By James G. Ray  
*Autogiro Company of America*



*“Rooftop landing facilities—  
Airport Connections,” may  
soon become familiar phrases  
in the rental of office space.  
The architectural require-  
ments for rooftop airports ap-  
pear to be relatively simple.  
Less confidence was felt about  
piloting problems until the  
author set out to reduce them  
to a systematized technique.*



***“When two direct control  
autogiros landed and took  
off from the roof of  
Philadelphia’s new central  
post office several weeks  
ago, I had first hand con-  
firmation of several theo-  
ries concerning rooftop op-  
eration evolved during the  
years I had heard it talked  
about...The general subject  
of rooftop operation, now  
concerning post office off-  
icials in many metropolitan  
centers, clearly involves  
aerodynamic as well as  
architectural principles and  
gives rise to the thought for  
streamlining all types of pro-***

***ducts...We are only concerned with streamlining to reduce turbulent air  
conditions around buildings. Slight changes in the shape of a building  
or group of buildings can affect an important improvement in aircraft  
operation from their roofs by lessening the violence of gusts and eddies  
which swirl about them in ever changing form. Basic causes of  
turbulence on and immediately around buildings naturally separate into  
two groups – wind currents and convection currents...”***

***Above: caption: “Roof of Philadelphia Post Office used to demonstrate feasi-  
bility”***



**Above: caption: “An autogiro lands on the grounds of the Washington post office with the Capitol in the background in 1939 to demonstrate the feasibility of a shuttle airmail service”**



**Above: in 1935 the *United States Army* bought a *KD-1* for evaluation and designated it the *YG-1*. A second aircraft followed which had additional radio equipment and was designated the *YG-1A* (above). These two aircraft were followed by seven more designated *YG-1B*.**

**Left: June 1938 magazine cover featuring a military Autogiro in an aerial dogfight**



**Left: caption: “*Wings over America*...KELLETT YG-1B AUTOGIRO...The United States Army’s autogiro fleet is composed of craft built by the Kellett Autogiro Corporation, pioneers in designing this type of flying equipment. The YG-1B type, now in use, is able to take-off abruptly (approximately 60 feet) and fly at forward speeds from zero (hovering) to 125 miles per hour and is able to land without forward roll.”**



In 1942, seven more KD-1B's were purchased by the *U.S. Army* for use in an observation role as the *XO-60* (top). Six *XO-60*'s were re-engined with 300-hp *Jacobs R-915-3*'s and re-designated *YO-60*. One *YG-1B* was modified with a constant-speed rotor and was redesignated the *YG-1C* (it was later re-engined with the more powerful *Jacobs R-915-3* and re-designated again as the *XR-2*). The *XR-2* was destroyed by rotor ground resonance problems and the evaluation was continued with another modified *YG-1B* designated the *XR-3* (bottom)



# *Congratulations!* EASTERN AIR LINES

Through your progressiveness and foresight in pioneering the first scheduled air mail service direct to a central city post office, you have added another page in the annals of aviation history.

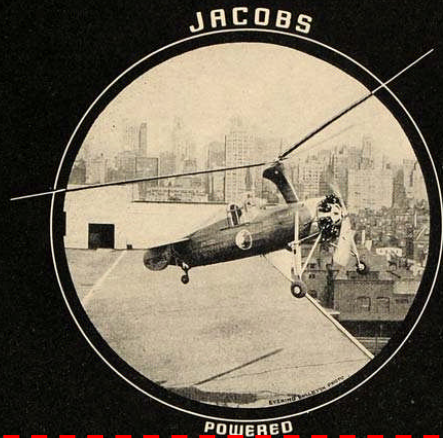

*Congratulations* also to the KELLETT AUTOGIRO CORPORATION for the development of the autogiro which makes this service practical.

THE JACOBS AIRCRAFT ENGINE COMPANY is very proud that JACOBS ENGINES were selected for this service in which the take-offs from a central city roof make engine reliability and efficiency absolutely essential.

225 H.P.

285 H.P.

330 H.P.

**JACOBS AIRCRAFT ENGINE CO.**

POTTSTOWN, PENNSYLVANIA

Cables—JAECO, POTTSTOWN

**“Congratulations! Eastern Air Lines...Through your progressiveness and foresight in pioneering the first scheduled air mail service direct to a central city post office, you have added another page in the annals of aviation history...Congratulations Also to the Kellett Autogiro Corporation for the development of the autogiro which makes this service practical. The Jacobs Aircraft Engine Company is very proud that Jacobs Engines were selected for this service in which the take-off's from a central city roof make engine reliability and efficiency absolutely essential.”**

RE: excerpt from a 1939 advertisement for the **Jacobs Aircraft Engine Company**

424

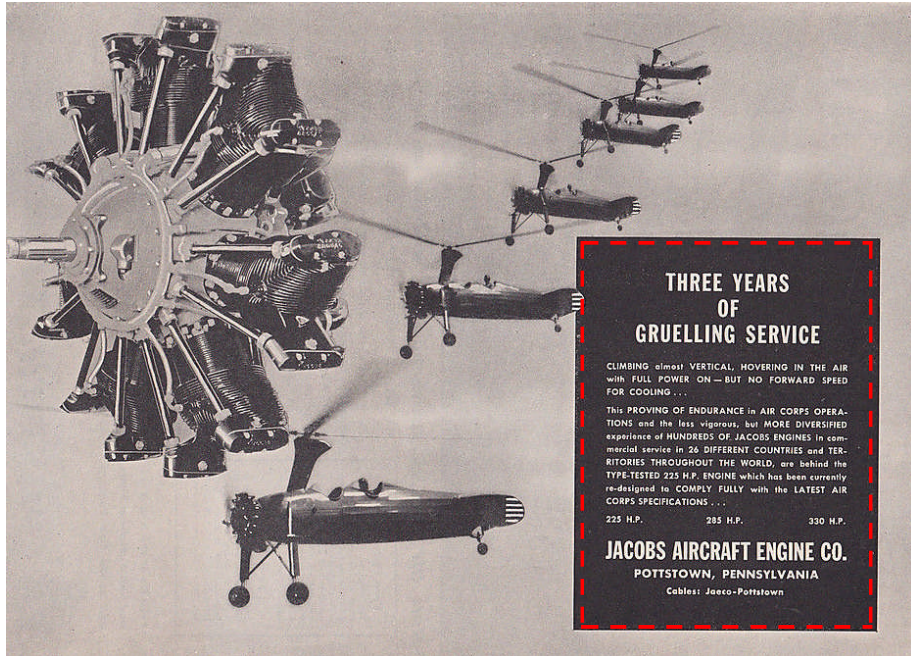

**Left: caption: “CLIMBING almost VERTICAL, HOVERING IN THE AIR with FULL POWER ON – BUT NO FORWARD SPEED FOR COOLING...This PROVING OF ENDURANCE in AIR CORPS OPERATIONS and the less vigorous, but MORE DIVERSIFIED experience of HUNDREDS OF JACOBS ENGINES in commercial service in 26 DIFFERENT COUNTRIES and TERRITORIES THROUGHOUT THE WORLD, are behind the TYPE-TESTED 225 H.P. ENGINE which has been currently redesigned to COMPLY FULLY with the LATEST AIR CORPS SPECIFICATIONS...”**



**Above: the *Imperial Japanese Army* developed the *Kayaba Ka-1* Autogiro for reconnaissance, artillery-spotting and anti-submarine duties. The Ka-1 was based on an American design; the *Kellett KD-1A*, which had been imported to *Japan* in 1939, but which was damaged beyond repair shortly after arrival. The Kayaba factory was then asked by the Army to develop a similar machine and the first prototype flew on May 26<sup>th</sup> 1941. Later, the *Imperial Japanese Navy* commissioned a small aircraft carrier, *Akitsu Maru*, intended for coastal antisubmarine (ASW) duty.**

Despite Cierva and Pitcairn's relationship as personal friends and joint business partners, their companies soon began to work separately. Information and developments did not flow easily between the two, especially from *England*. Both firms were wary of the other and wanted to be the first to develop direct control and jump take-off ability. *Juan de la Cierva* had his finest hour at the 1933 Chicago World's Fair. On June 28<sup>th</sup> 1933, Cierva received the *Daniel Guggenheim Medal* at *Soldier's Field* in front of thousands of spectators. The medal was for the "World's most notable Achievement in Aviation" and had only been previously awarded three times. The future of the Autogiro was drastically altered three years later when, on December 9<sup>th</sup> 1936, *Juan de la Cierva* perished when the KLM DC-2 that he was flying in from *London* to *Amsterdam* crashed while taking-off in low visibility conditions. Cierva was posthumously awarded the Royal Aeronautical Society's prestigious *Gold Medal*. *Fortune* magazine went as far as to proclaim Cierva's Autogiro "the only basic contribution to the art of flight since the Wright brothers rode a biplane into the air in 1903."

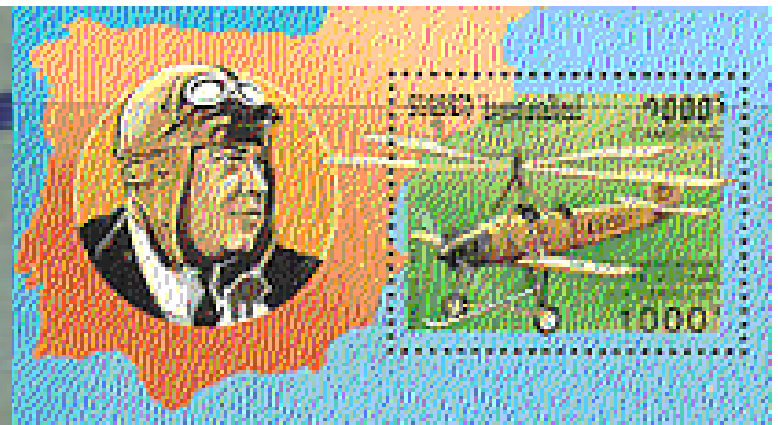

***“Juan Cierva will be known to enduring fame as the outstanding pioneer in the field of rotary-wing aircraft...All helicopters and similar types of craft that have shown promise of practical performance incorporate some of the principles and inventions developed by Cierva”***

***Harold F. Pitcairn***

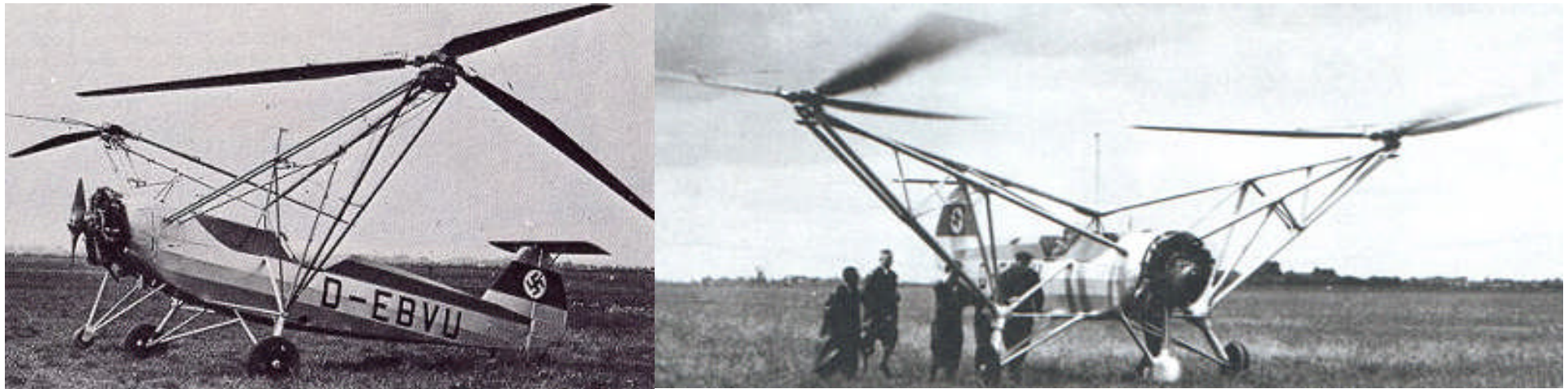

With Cierva no longer available to facilitate communication and act as go-between between for the companies on either side of the *Atlantic*. *Harold Pitcairn* found it increasingly difficult to get information on what was happening in *England* at the *Cierva Autogiro Company (CAC)*. This despite the fact that Pitcairn was a board member of the English company. A confrontation between Pitcairn and the other board members ensued. Pitcairn was shocked to learn that CAC had licensed its cyclic and collective control systems to Germany's *Focke Achgelis Company*. Focke Achgelis subsequently used these licenses to build what is considered to be the first successful helicopter; the *Fa-61/Fw-61* (above L&R). CAC later received a license to build Fa-61 helicopter derivatives. This venture into helicopter manufacturing effectively ended European Autogiro development. Pitcairn returned to the *United States* undeterred and resolved to continue to forge ahead with the Amer- 429  
ican Autogiro.

During its retirement from public activity, the **AUTOGIRO COMPANY OF AMERICA** has been concentrating on the solution of fundamental technical problems. At this time we are pleased to announce that these problems have been both fully and satisfactorily solved.

HAROLD F. PITCAIRN, PRESIDENT



PITCAIRN-LARSEN AUTOGIRO COMPANY, Inc. • WILLOW GROVE, PENNA.

In 1938, the company was renamed the *Pitcairn-Larsen Autogiro Company*. In 1940, it was once again renamed: the *AGA Aviation Corporation*.

Left: advertisement for the Pitcairn-Larsen Autogiro Co., Inc. The highlighted area reads: “During its retirement from public activity, the **AUTOGIRO COMPANY OF AMERICA** has been concentrating on the solution of fundamental technical problems. At this time we are pleased to announce that these have been both fully and satisfactorily solved. Harold F. Pitcairn, President”



The *Pitcairn XO-61* (1943) was the last Autogiro designed by *Pitcairn Aircraft* and one of the last Autogiros ever produced. In competition with the *Kellett YO-60* and the *Sikorsky R-4*, it fell victim to cooling problems with its rear-mounted engine and the coming of the helicopter with its ability to hover. It was also known by the company model number *PA-44* and the contract designation *MX-157*. The contract for the XO-61 was taken over by G&A Aircraft upon G&A's acquisition of Pitcairn Air- 431  
craft in 1942.



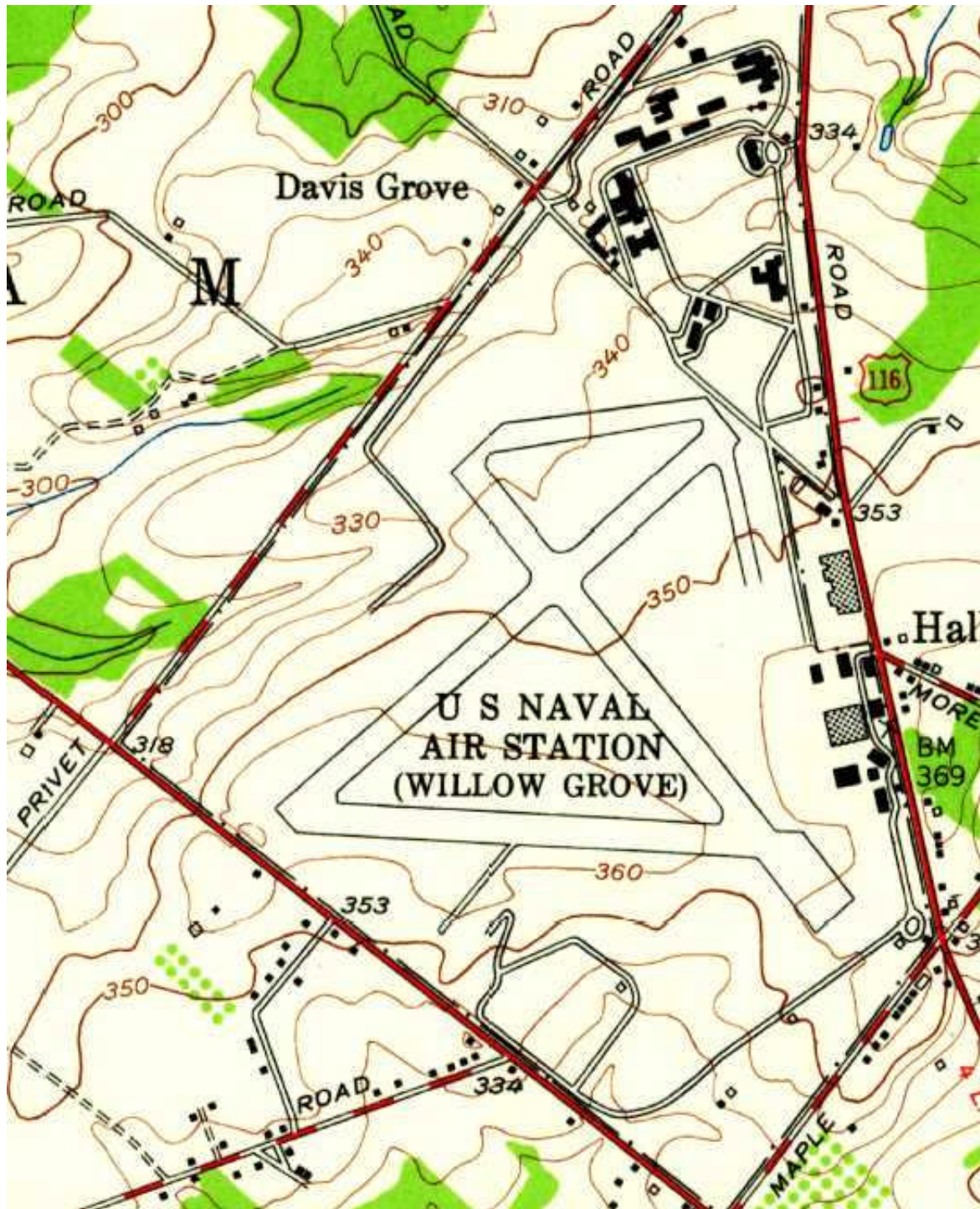

At the beginning of WWII, the *Federal Government* was in need of places to train new pilots for the war effort and was preparing to acquire the inactive *Pitcairn Field* via eminent domain. In order to avoid the associated legal proceedings, *Harold Pitcairn* sold the airfield outside *Philadelphia* that bore his name to the government for its appraised value. Pitcairn Field later became *U.S. Naval Air Station Willow Grove*

Above: caption: "USNAS Willow Grove – May 8, 1944" 432



**Above T&B & Left: in 1957, the U.S. Navy purchased additional land, bringing the Willow Grove NAS to a <sup>433</sup> total of 1,100 acres. It also hosts USAF reserve units.**

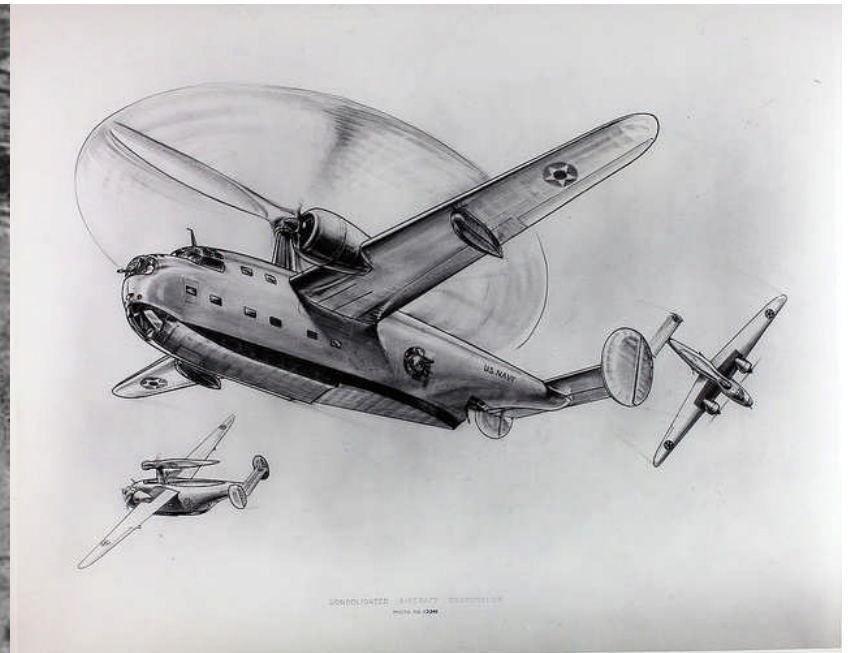
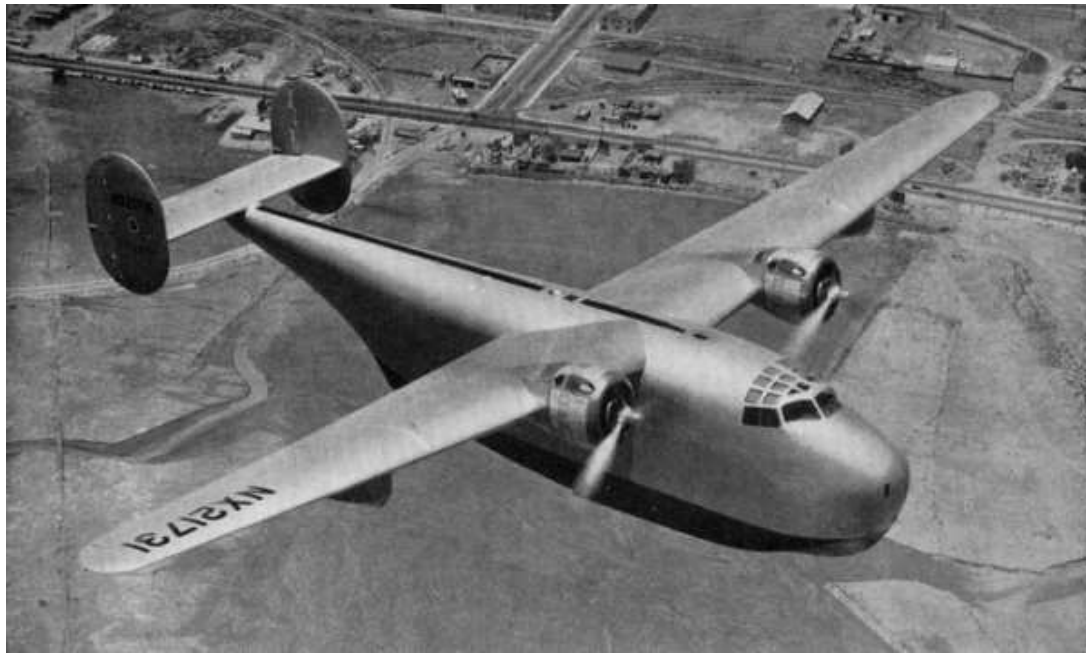

**Above: Consolidated Model 31 XP4Y-1. First flown in May 1939 (later named *Corregidor*), the flying boat was to be produced for the *U.S. Navy* at a new assembly plant near *New Orleans*. However, the October 1942 order for two-hundred planes was cancelled (due to a shortage of engines) before any aircraft were produced and only the one prototype ever flew (left). The drawing at right depicts the Model 31 as an Autogiro variant. It was the first aircraft designed with a high aspect-ratio *Davis Wing*. This increased fuel efficiency and was later used on the famous *B-24 Liberator* bomber of WWII fame.**

# **Pitcairn v. United States**

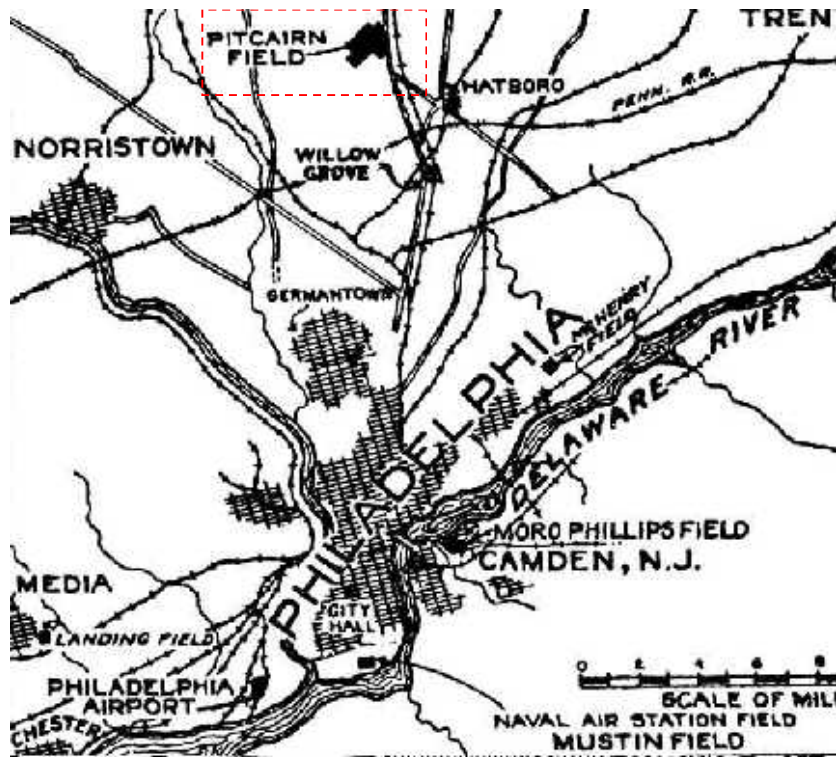

In 1943, in a patriotic attempt to help the war effort, *Harold Pitcairn* offered to reduce the royalties on his nineteen personal rotary-wing patents and another 145 patents held by his company from 5% to 0.85% for any licensee supplying the U.S. Government. His generous offer was accepted by the government for the duration of the war plus six months. The offer expired in 1946, at which time some of the biggest helicopter manufacturers continued to supply the government while using Pitcairn's patents without properly compensating him. In 1951, after failing to reach an industry wide settlement, Pitcairn filed a lawsuit against the U.S. Government which had indemnified the helicopter manufacturers. The ensuing litigation became the longest patent suit in American history. It finally concluded in 1977 after reaching the *U.S. Supreme Court*. Pitcairn received \$14 million in unpaid royalties and \$17 million in back compensation. Unfortunately, this settlement came nearly seventeen years after Harold Pitcairn's death. On July 22<sup>nd</sup> 1960, Harold Pitcairn died in his home as a result of a gunshot wound. The events surrounding his death remain unclear.

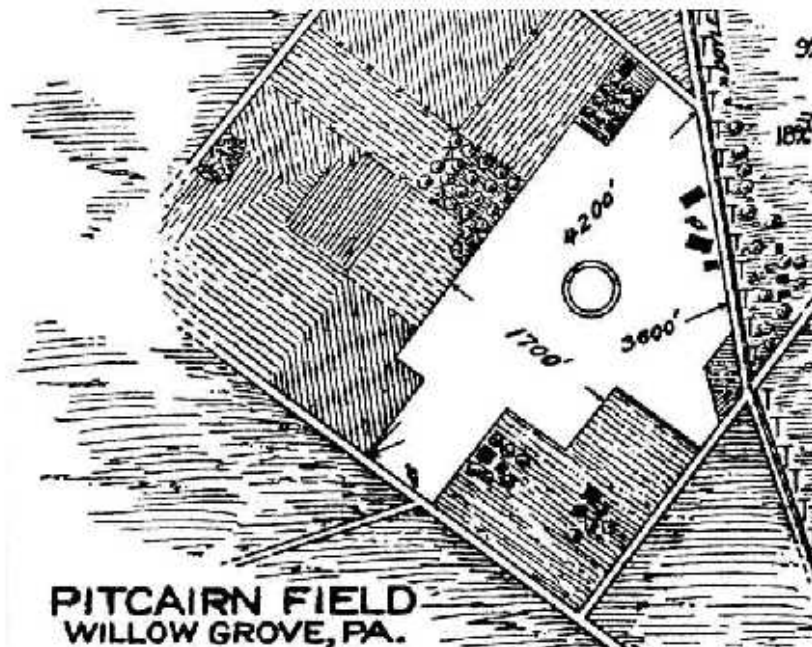

**Although direct control and jump take-off ability increased the Autogiro's capabilities, the helicopter soon became reality and interest in the Autogiro faded. Government funding was funneled into helicopter development effectively cutting out the Autogiro companies. Harold Pitcairn's *Autogiro Company of America* was acquired by *Firestone Tire & Rubber* in 1942 and renamed *Firestone Glider & Autogiro Company* (a.k.a. *G&A Aircraft*). By 1948, after failing to market a successful helicopter, G&A Aircraft was out of business.**

***“...we can honeymoon in Cairo in our brand new Autogiro...”***

**RE: excerpt from a 1945 popular song entitled *I'll Buy That Dream* (as sung by crooner *Dick Haymes* to *Helen Forrest*). By 1945, it would be very difficult to take an Autogiro trip anywhere in the world.**

# Part 6

# Convertiplane



# Zaschka



Abb. 39. Zaschka-Rotations-  
flugzeugprojekt

In 1927, *Engelbert Zaschka* of *Berlin, Germany* built a helicopter equipped with two rotors in which a gyroscope was used to increase stability and serve as an energy accumulator for a gliding flight to make a landing (gliding in this case meant a straight descent). His goal was to develop an efficient propeller drive. A swiveling propeller at the rear provided both propulsion and rudder control. The machine (above) was a combination of an Autogyro and a helicopter. Zaschka stated that the principal advantage of the machine was its ability to remain motionless in the air for any length of time and to descend in a vertical line so that a landing could be accomplished on the flat roof of a large house. In appearance, the hybrid helicopter did not differ much from the ordinary monoplane, except for the fact that the wings revolved around the fuselage.

# **A Bird-Like Appearance**

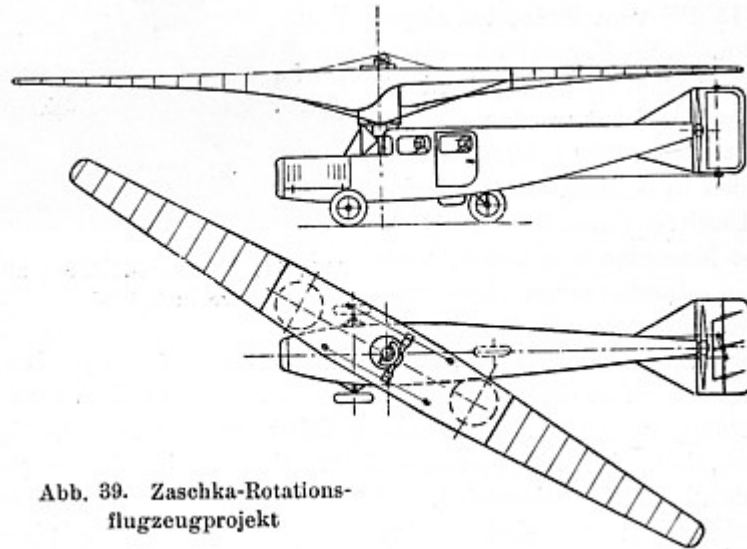
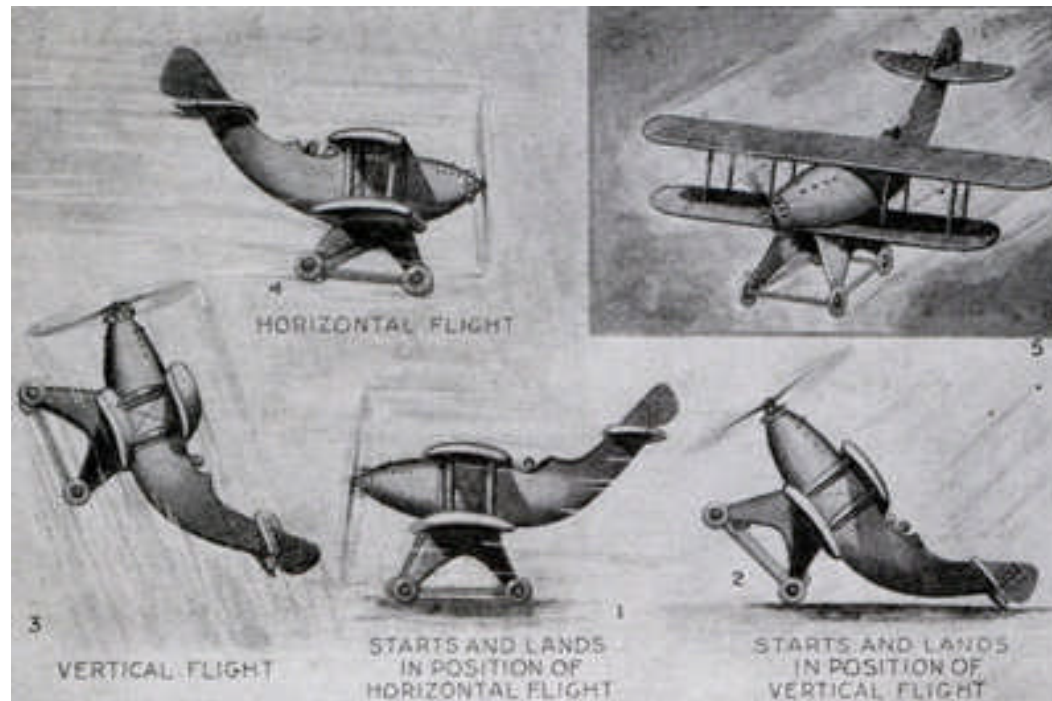

***“The machine illustrated above, in various operating positions, is the subject of a recent U.S. patent issued to Umberto Savoia, and assigned to the Fiat Co., well-known Italian manufacturers. Its purpose is to unite the horizontal flight of the ordinary plane with the vertical flight of the helicopter; without complexity of machinery to convert horizontal drive into vertical. As will be seen, the plane can be tilted back at right angles, so that the traction of its propeller is vertical; and land in either position. Another design contemplates a double body, in which the rear fuselage is hinged to the front, so that the angle between the two may be altered. Wide ailerons and large empennage will be required, and powerful engines, probably with a propeller (or pair) of variable pitch.”***

***Science and Mechanics, January 1933***

***Above: caption: “There is a bird-like appearance about this odd plane design, recently patented (No. 1,875,276)”***

# **A Wingless Craft**

**“Jets of air, sucked in at the front and expelled at the rear of huge tubes, are the unconventional means advanced by a Glendale, Calif., inventor for lifting and propelling an airplane. He has designed and patented a wingless craft, employing this principle, which he maintains will be able to rise and descend vertically and to hover motionless aloft. According to the inventor’s plans, a propeller and motor are installed within each of two tubes, which in turn are so mounted above a standard airplane fuselage that they may be swung by the pilot to any angle. For a take-off, the tubes are to be operated in a perpendicular position, thus providing a vertical lifting force. Once in the air, the pilot would tilt the tubes ahead, in order to cause the plane to travel forward. An auxiliary propeller on the fuselage is provided to aid in forward travel, while rudders steer the plane.”**

**Popular Science, February 1934**

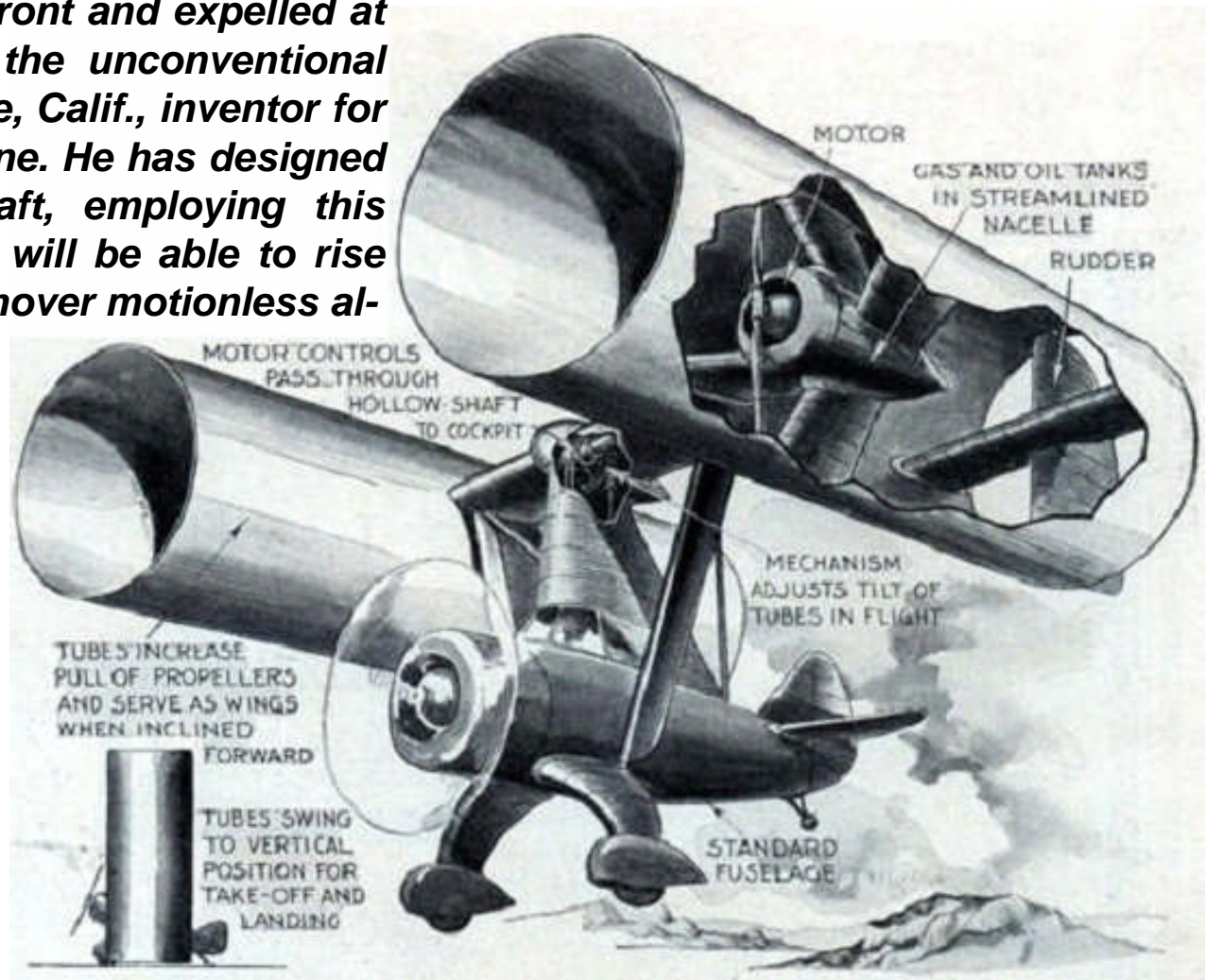

**Above: caption: “Illustration showing how wingless cylinder plane would be driven by jets of air forced out by motors in cylinders. Note, angle of tubes can be adjusted for take off or flight.”**

**Call It a “Vertaplane”**



***“Called a vertaplane, a new airplane which successfully completed its first public flight recently combines many of the features of autogiros and conventional aircraft. The upper***

***wing of the novel ship remains stationary in normal flight, but whirls like an autogiro blade to permit take-offs and landings at slow speeds and in confined areas.”***

*Popular Science, October 1937*

**Left: caption: “This drive mechanism rotates the wings for takeoffs and landings**

**Right: caption: “The odd craft flying as a plane, with its top wing stationary”**



# **The Future of Flight**

# Symbol . . . . .



**T**HE FAIREY SYMBOL is the emblem of a Company which, in its thirty-five years' growth, has become a group with world-wide ramifications. In Canada, Australia and Belgium companies linked to Hayes are operating, busy on manufacture, research, repair and specialised development.

At home, Fairey engineers are probing the future of flight in its most advanced aspects. In parallel with the naval development which has always been their main preoccupation they are at work on the problems of trans-sonic and pilotless flight, electronic and power control, rotary wing development and new arms for Western defence. In all these fields great progress is being made and in all parts of this organisation there are careers waiting for young qualified men with an eye to the future. *They'll find a future in Fairey's.*

# FAIREY

***“THE FAIREY SYMBOL is the emblem of a Company which, in its thirty-five years' growth, has become a group with world-wide ramifications. In Canada, Australia and Belgium companies linked to Hayes are operating, busy on manufacture, research, repair and specialized development. At home, Fairey engineers are probing the future of flight in its most advanced aspects, in parallel with the naval development which has always been their main preoccupation they are at work on the problems of trans-sonic and pilotless flight, electronic and power control, rotary wing development and new arms for Western defense. In all these fields great progress is being made and in all parts of this organization there are careers waiting for young qualified men with an eye to the future....”***

*Enquiries to Personnel Manager :*

THE FAIREY AVIATION CO. LTD . HAYES . MIDDLESEX



The story of the *Compound* (a.k.a. “Convertible”) helicopter endeavors of the *Fairey Aviation Company* can be told as a continuing fifteen-year saga of experimental development, testing, successes and failures. The *Gyrodyne*, *Jet Gyrodyne* and *Rotodyne* stemmed from a fundamental rethinking about helicopter and Autogiro principles and philosophies. In preparation for the move into rotary-wing development, Fairey built-up a strong helicopter team, led by *Dr. J.A.J. Bennett*, who brought the Gyrodyne proposal to the company in August 1945. The first official announcement of the project, was made on April 3<sup>rd</sup> 1946. At that time, the Gyrodyne was known as the *FB-1 (Fairey-Bennett One)*.

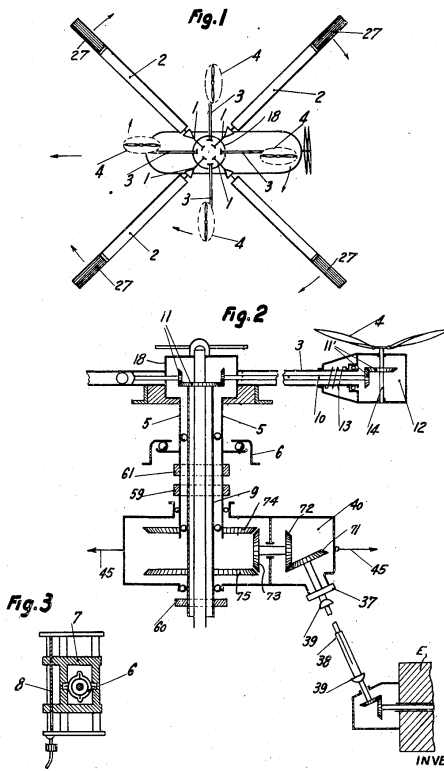

INVENTOR  
LOUIS ADOLPHE HAYOT  
BY  
*Richard & Geier*  
ATTORNEYS

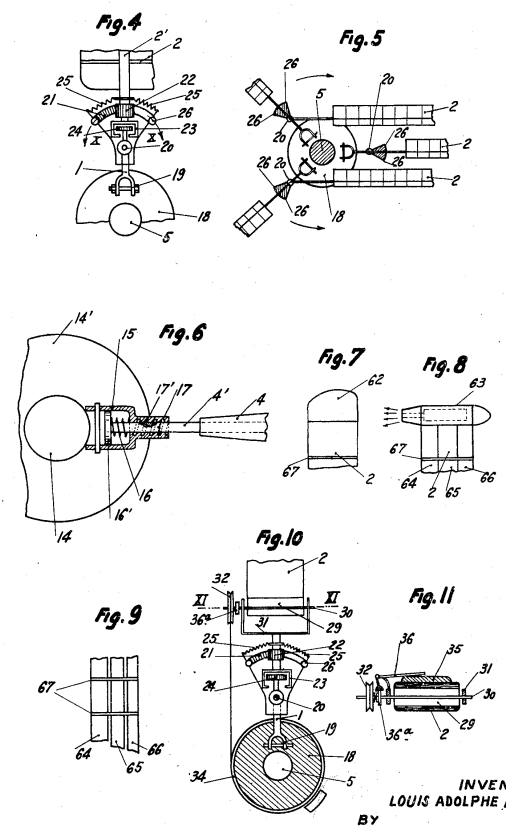

INVENTOR  
LOUIS ADOLPHE HAYOT  
BY  
*Richard & Geier*  
ATTORNEYS

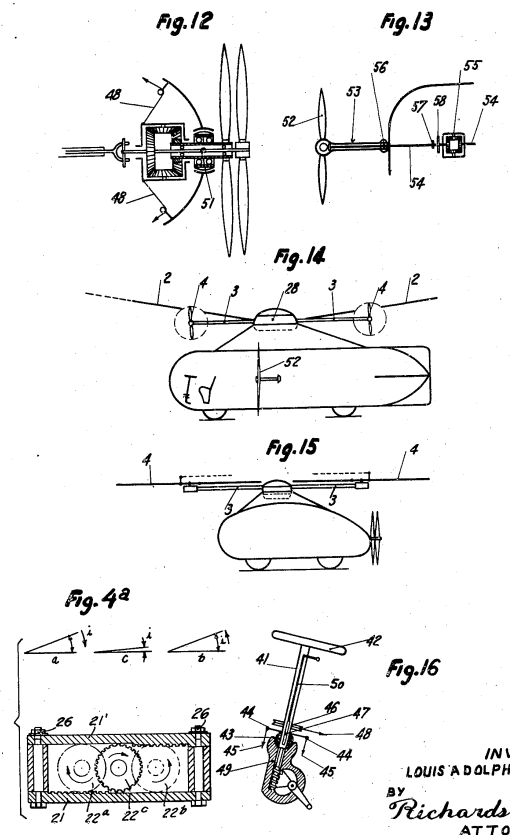

INVENTOR  
LOUIS ADOLPHE HAYOT  
BY  
*Richard & Geier*  
ATTORNEYS

**Above: "DESCRIPTION: Dec. 13, 1949 A. HAYOT 2,491,042. FLYING MACHINE, INCLUDING FEATURES OF A HELICOPTER AND AN AUTOGIRO. Filed Nov. 7, 1946...Patented Dec. 13, 1949 UNITED STATES Louis Adolphe Hayot, Paris, France. Application November 7, 1946...In any case, the compensating airscrews are characterized by the fact that, as soon as they cease to be driven by the engine, the inclination of their shafts and the direction of their pitch are modified automatically in such a manner that they continue to rotate in the same direction, by an effect of auto-rotation, and contribute in the supporting of the machine during the landing..."**

**In the Autogiro, a freely revolving rotor provided lift in autorotation down to very low airspeeds; propulsion was by an engine-driven propeller. During later development, means of short-period vertical ascent and descent were provided by a power-drive to spin up the rotor and/or by using the kinetic energy of the rotor to provide direct lift. In the helicopter, the rotor was continuously power-driven, providing both lift and, when tilted forward, the means of propulsion. Control in yaw was maintained by altering the pitch of a powered lateral-thrust propeller in the tail.**

# Gyrodyne

**The FAA describes a *Gyrodyne* as a “rotorwing” aircraft that powers its rotor for take-off and landing, but which functions in flight like a *Gyroplane*. This gives the aircraft the ability to hover as well as take-off and land vertically, but it is in every other respect a gyroplane, with forward thrust being provided by engine driven propellers and lift provided by a free-spinning rotor that is not powered in forward flight. A *Gyrodyne* therefore retains all the advantages and simplicity of a gyroplane, but adds important functionality. Because traditional rotary-wing designs use the rotor for both lift and thrust, physics-imposed design restrictions and trade-offs limit their size, speed and lift capabilities. In contrast, a *Gyrodyne* uses its engine and propeller only for thrust, while the free-spinning rotor provides lift. Separating these functions in this manner made possible a new type of rotorcraft.**

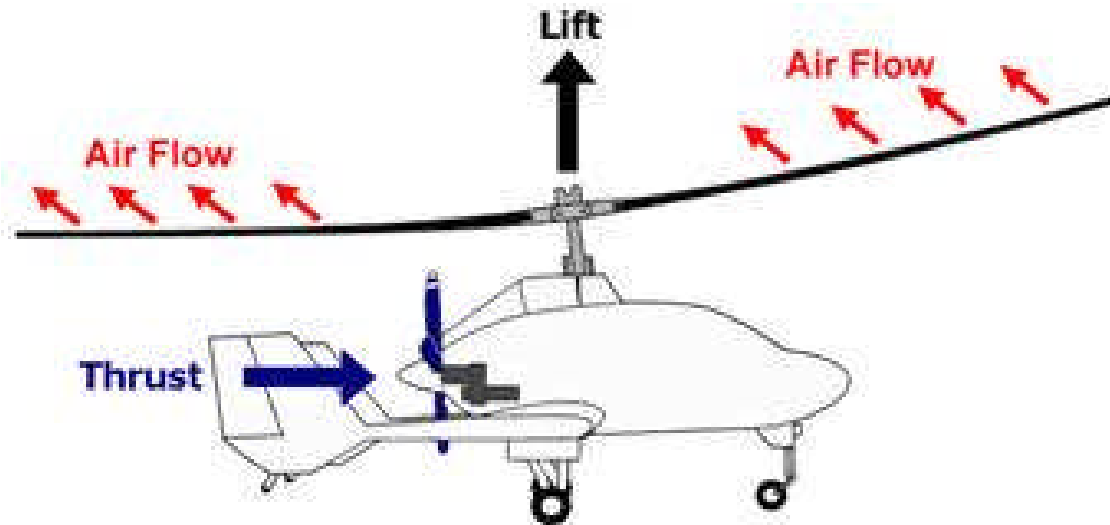

**Above:** caption: “Gyroplanes derive lift from freely turning rotor blades tilted back to catch the air. The rushing air spins the rotor as the aircraft is thrust forward by an engine-driven propeller. Early gyroplanes were powered by engines in a tractor (pulling) configuration and were relatively heavy. Modern gyroplanes use a pusher propeller and are light and maneuverable. With the engine in the rear, the gyroplane has unobstructed visibility:

- Thrust is produced by an engine-driven propeller;
- The un-powered, freely turning rotor is tilted back as the gyroplane moves forward;
- Oncoming airflow through the rotor causes it to spin, producing lift. This is called *autorotation*;

Always operates in autorotation, thus:

- Cannot stall like fixed wing aircraft;
- Flies safely at low altitudes and low speeds, but cannot hover, and;
- No need for heavy main rotor transmission nor a tail rotor”



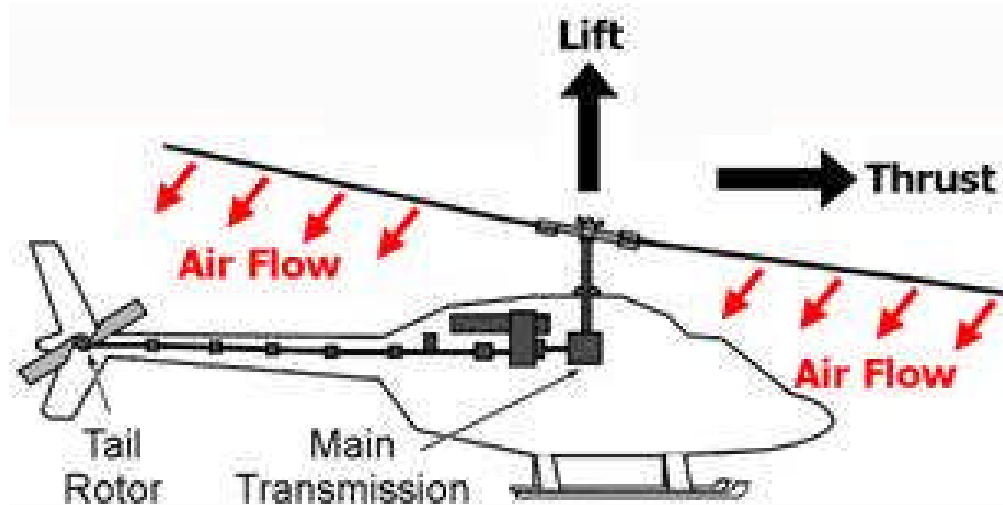

**Above: caption: “A Gyroplane can fly more slowly than airplanes and will not stall. They can fly faster than helicopters but cannot hover. Since the rotor blades on the gyroplane are powered only by the air (autorotation), much like a windmill, there is no need for a tail rotor for anti-torque. The gyroplane is a stable flying platform. This is not so with helicopters, which pull the air down through engine-powered rotor blades making it possible to hover, but also making the aircraft very complicated and expensive to fly. Due to their inherent simplicity, gyroplanes are easier to operate and less expensive to maintain than helicopters.**

**In the Helicopter:**

- The powered rotor produces both lift and thrust, and is tilted forward;

**Can hover, but a powered rotor requires:**

- Adequate forward speed and/or altitude to maintain flight in case of power failure;
- A heavy main transmission, and;
- Tail rotor to counteract the torque imposed on the aircraft”

### Typical Helicopter Powered In-flight Components

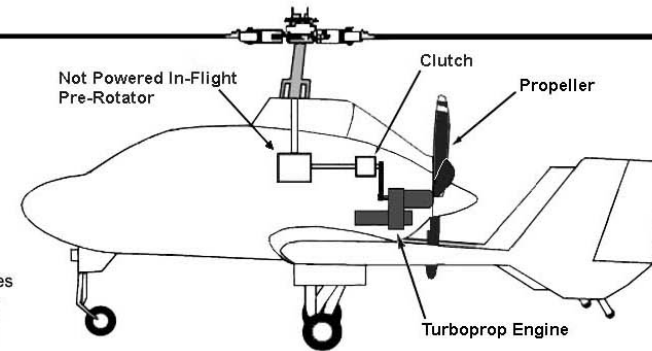
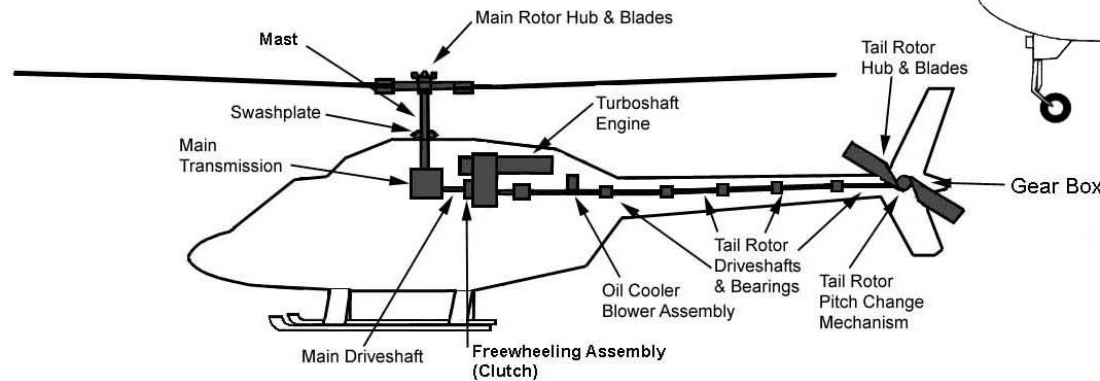

### Typical Gyroplane Powered In-flight Components

**Above:** caption: “The simplicity of a gyroplane’s design translates directly into safety, higher performance, higher mission readiness, lower maintenance, and more economical operation for its operator. Gyroplanes in flight are always in autorotation. If power fails in a gyroplane the autorotation continues, and the aircraft settles softly to the ground from any altitude. The procedure to land after a power failure is nearly the same procedure as a normal landing, which requires no landing roll. Thus the gyroplane is a safer aircraft for low and slow flight, as compared with both helicopters and airplanes. The ability of gyroplanes to fly faster than helicopters and slower than airplanes makes it something of a hybrid, having the good qualities of the other two types of aircraft with little of the bad. The single attraction of helicopters over gyroplanes is their ability to hover, which is necessary in some situations such as rescue or in sling load work. In air surveillance and point-to-point flying, not being able to hover is not a disadvantage because many gyroplanes, such as the Groen Brothers Hawks, take-off and land vertically without having to hover. Helicopters at low altitude out of ground effect avoid hovering whenever possible. It is too dangerous. To fix surveillance on one spot, proper procedure for all rotorcraft is to circle in a slow orbit.”<sup>457</sup>

The *Gyrodyne* (*Gyratory Aerodyne*) was designed to take advantage of the favorable features of the Autogiro and the helicopter while avoiding some of their respective limitations. The aim was to obtain greater operating efficiency while reducing the loads on transmission and rotor systems which were then considered by many technicians to be severely, if not dangerously, stressed throughout each flight. By using a propeller for normal propulsion, as well as for control in yaw at low speeds, the “balance of power” was reversed so that rotor and transmission loads were greatly reduced during most of the time while airborne. The fact that the rotor was not being used for propulsion meant that this would be operating for long periods within or near the autorotative pitch-range and with a lower disc loading. In the *Gyrodyne*, the rotor continued to be the sole means of sustaining lift (apart from the marginal lift provided by the stub wings in cruising flight) and was continuously power-driven. However, when hovering or in slow-speed flight, the greater part of the available power went to the propeller in order that it could provide propulsive power (while retaining its use for anti-torque and slow-speed yaw control). In the *Gyrodyne*, it was moved from the tail to an equivalent azimuthal location at the end of the starboard stub wing where it was still far enough from the axis of the rotor to absorb minimum power when used for control in yaw. An important incidental advantage of the smaller angles of blade incidence and reduced loading on the non-propulsive rotor was that higher cruising speeds were possible before the onset of the stall for the retreating blade - an inevitable event which limited (and still limits, if only because of vibration) the speed of a conventional helicopter.

Although the broad concept was relatively simple, the translation of this concept into a working flying machine involved considerable effort in engineering and other manufacture. An idea of the amount of “machinery” in the prototype can be realized from the fact that nearly 50% of the empty weight was contributed by the power-plant and transmission systems. The *Gyrodyne* had an ingenious and comparatively straightforward control system. The rotor articulation was designed so that the collective-pitch changed automatically according to the power being applied. The throttle lever was therefore designed to be similar in length, movement and effect to the collective-pitch control of a conventional helicopter and was pulled up to increase power and lift. Fore-and-aft and lateral control was provided by a form of tilting head (although the rotor-hub axis did not physically tilt as in the case of most Autogiros). A similar effect was produced by tilting the rotor head in relation to the axis. Stick-shake was eliminated, using suitable safeguards, by controlling rotor-tilt through irreversible hydraulic jacks. Yaw control was maintained (as with helicopters) by altering the pitch of the propeller through conventional pedals. Rudders were fitted for directional control during autorotative flight after power failure. An “elevator” (in the form of a large trim tab) was used to adjust the fuselage attitude when cruising.

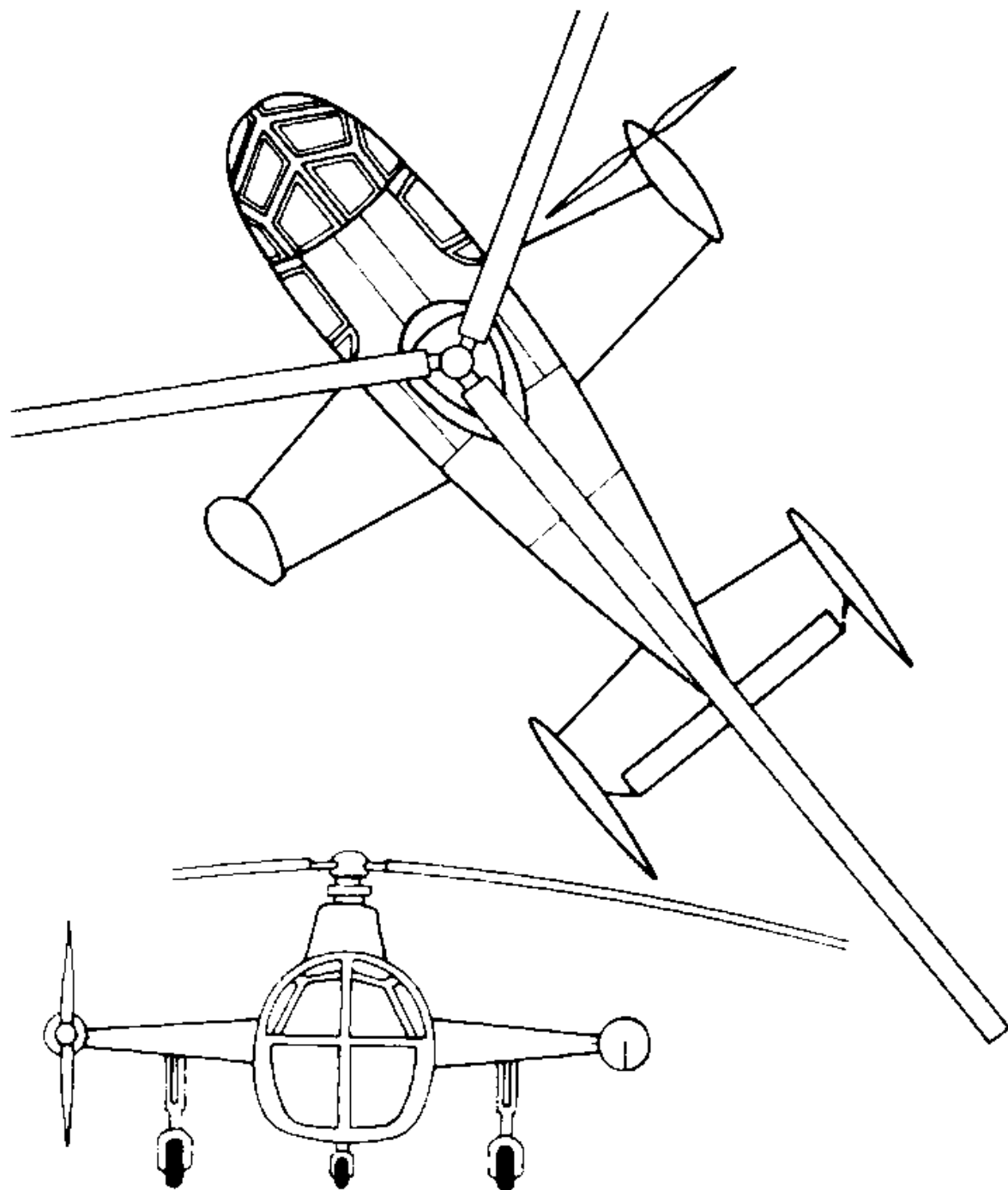

In April 1946, *Fairey* announced a private-venture project for a rotary-wing aircraft, to be built to a new concept originated by *Dr. J.A.J. Bennett* who had joined the company the previous year. Dr. Bennett had assumed control of the *Cierva Autogiro Company* in 1936, following the death of *Juan de la Cierva* and Bennett's ideas were based on the combination of a lifting rotor plus an asymmetric propeller mounted on a stub wing, which would counteract yaw and provide thrust, lessening the loading on the rotor.

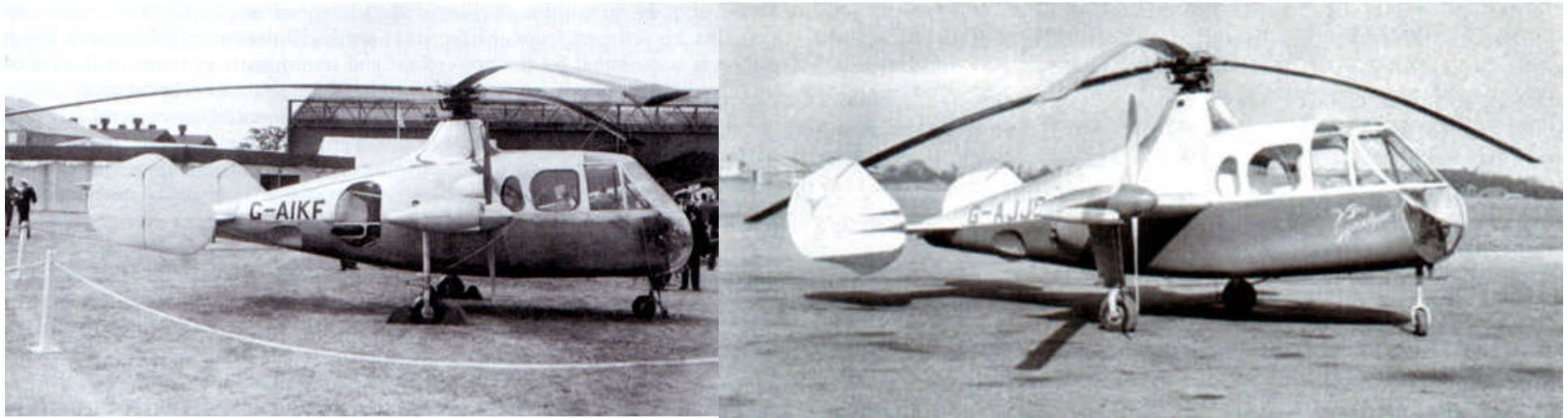

**A government contract was awarded for two prototypes and the first *Fairey Gyrodyne* (left) was exhibited almost complete at *White Waltham* on December 7<sup>th</sup> 1946 and continued to build-up flying time until March 1948 when it was dismantled for a thorough examination. The second prototype (right) was similar to the first but with more comfortable interior furnishings (befitting its role as a passenger demonstrator). It was flying by the time of the annual *Farnborough Air Show* in September 1948. The first Gyrodyne was re-assembled and, following further test flights, it was decided to make an attempt on the world's helicopter speed record (flying in a straight line).**

**Left: caption: "Fairey Gyrodyne Before its initial flight in December 1947. The rudders were fitted for control in autorotative flight after possible engine failure."**

**Right: caption: "The second prototype Gyrodyne was similar to the first, but more comfortably furnished for demonstrations"**

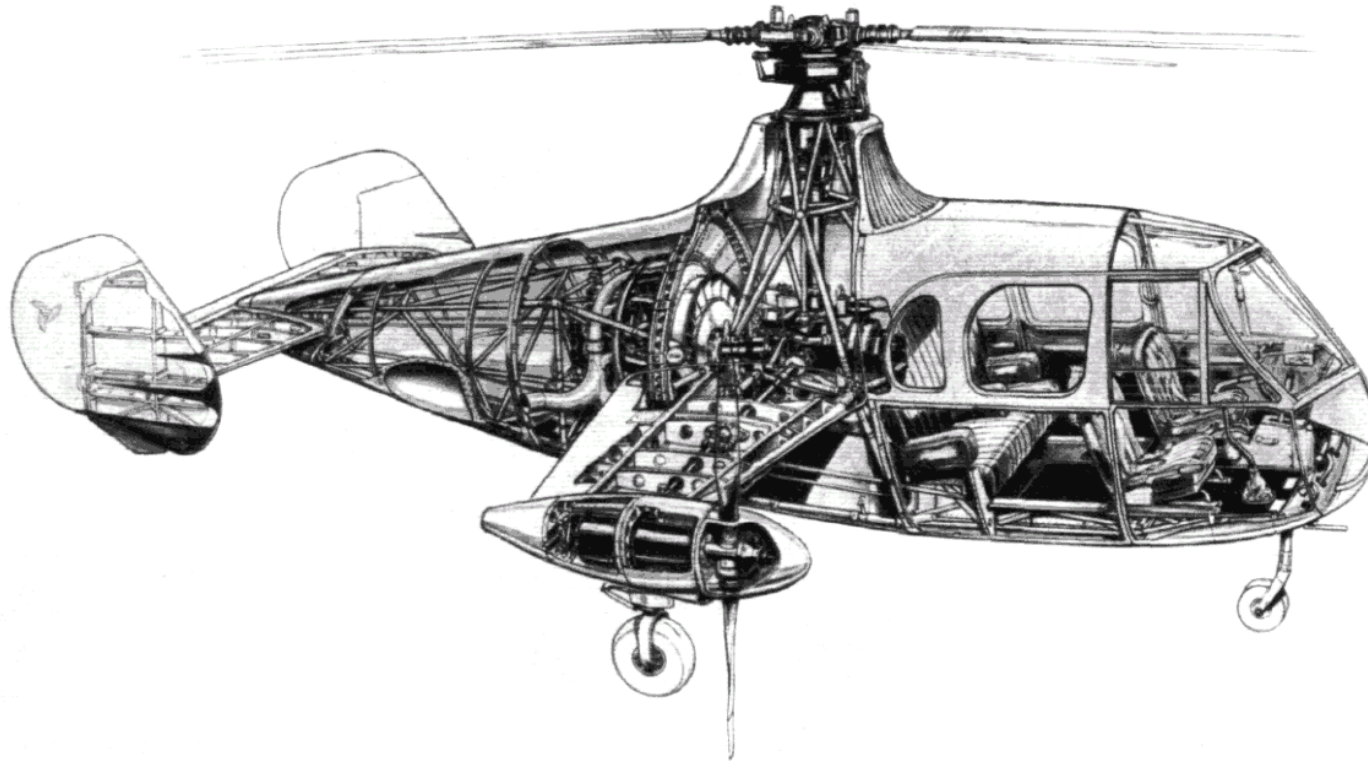

On December 4<sup>th</sup> 1947, the first of the two prototypes of the *Gyrodyne* (weighing just over 2K-kg) took off from *White Waltham* airport. With a 525-hp Alvis *Leonides* radial engine, the power from which could be transmitted in variable ratios to a three-blade rotor (just over 15m in diameter) and to the anti-torque propeller on the starboard tip of the stub wing, the Gyrodyne behaved like a helicopter, but the same propeller also provided the necessary thrust for fast flight (when the aircraft looked like an Autogiro). The British compound aircraft set a world speed record by flying at 200km/h on June 28<sup>th</sup> 1948. An extensively modified second prototype (renamed *Jet Gyrodyne*) flew in January 1954. It had two blade-tip jets fed with air from two compressors driven by the radial engine.



**An attempt was to be made in April 1949 to set a 100km closed-circuit record, but two days before the date selected a rotor head fatigue failure resulted in the crash of the aircraft at *Ufton*, killing the pilot and his observer. Subsequently, the second prototype *Gyrodyne* was grounded for investigation into the cause of the crash and the aircraft did not appear again until 1953. In the intervening years it was redesigned and modified to become the *Jet Gyrodyne*, providing critical data for Fairey's big project - the *Rotodyne*.**

**Left: caption: "The Gyrodyne is run-up before take-off. The propeller on the starboard stub-wing provided forward thrust as well as counteracting rotor torque"**

**Right: caption: "The first Gyrodyne, G-AIKF, being demonstrated at White Waltham early in 1949 after it had, in June the previous year, broken the world's helicopter speed record"**



# Jet Gyrodynes

**Towards the end of 1953, the surviving second prototype *Gyrodyne* reappeared in a very different form. Following a long period of test work with static rigs at *White Waltham*, the principles and operation of the tip-jet rotor-driving system had been reasonably well proven. A research contract was received from the *Ministry of Supply*, the basic layout of the *Rotodyne* established and the time had come to try the principles in practice. This was necessary not only to continue the testing of the tip-jet/s, but to develop handling and other procedures for the compound/convertible helicopter. By early January 1954, the *Jet Gyrodyne* was making tethered flights at White Waltham (the first free flight was made late in January 1954).**

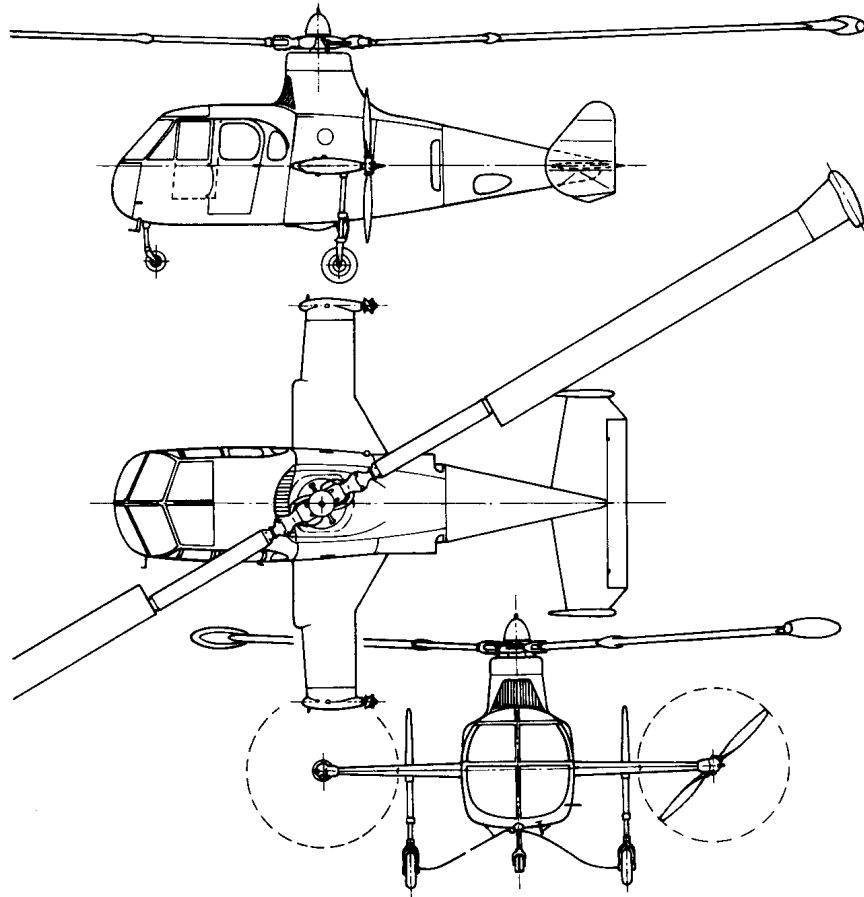

While the Jet Gyrodyne retained the basic appearance and engine of the earlier model, it had a two-bladed main rotor with pressure burners at the tips in place of the conventional three-bladed rotor and at the end of the stub wings were two Fairey variable-pitch pusher propellers. These were driven by the *Leonides* engine which no longer drove the main rotor. instead, two *Rolls-Royce Merlin* compressors pumped air under pressure to the rotor tips.



The key units in the *Jet Gyrodyne* were the tip burners (which had been successfully developed after failures by other designers in a similar field). Compressed-air from the blowers passed through the rotor blades while centrifugal force fed the metered fuel through the blades to the jets. The compound/convertible, helicopter principle of the *Jet Gyrodyne* and the *Rotodyne* was as follows:

- Lift for take-off, slow flight and landing was provided by the jet-driven rotor;
- For transition to cruising flight the compressed air to the rotor tips was progressively reduced and available engine power transferred to the propellers, leaving the rotor as an autorotating lift unit which was supplemented (in a very minor proportion for the *Jet Gyrodyne*) by the fixed-wing

467

The procedure was reversed for a return to the helicopter mode of operation.



The transition operation was extremely difficult in practice until suitable protocols had been established. The problem for the *Jet Gyrodyne* was accentuated by the fact that it was, at a gross weight of 2720kg, under-powered for the work it had to perform and the *Leonides* engine was normally operated at maximum boost. In fact, the *Jet Gyrodyne* could not quite maintain level flight in the cruising (autorotative) mode. As such, it was not until March 1<sup>st</sup> 1955 that a successful transition was completed (right). This was the first time that a practical transition cycle in flight had been completed by any aircraft. Within four months of this first full transition, the techniques had become well established and transition was no longer being accompanied by a considerable loss of height. The cycle was demonstrated at *Farnborough* in September 1955 (left). In fact, while practicing for this demonstration, sixty-five successful in-flight tip-jet re-lights were accomplished during eight days. Even during the earlier period of testing, the transition from helicopter to Autogiro flight was relatively easy. The basis of the operation was the transfer of engine power from the jet-feeding compressors to the propellers. The pitch of the propellers was progressively coarsened thus absorbing more power and reducing the air delivery to the jets (which eventually flamed out) and the compressors were declutched. It was found that transition could be made at widely varying speeds, but 128km/h was found to be the most convenient, 468 with a rotor speed of about 210 rpm.



The really difficult operation was the transition back to helicopter flight. A great deal of flying was required before the best propeller-pitch and tip-jet re-lighting sequence could be established. A major part of the difficulty was that, with the compressors being driven, there was no reserve of engine power for the propellers during the re-lighting sequence and the aircraft descended rapidly in autorotation until the jets had been re-lit. So long as the re-lighting was being done over or near an aerodrome there was no particular danger in this situation; a controlled landing could be made (and often was, in autorotation). As finally established, the drill was to throttle back momentarily, engage the compressor clutch, switch on the tip-jet ignition and fuel supply and progressively fine-off the propeller pitch. This automatically opened the intake-valves for the compressors. The tip-jets re-lit when a certain head pressure had been reached and collective-pitch was increased to keep the rotor speed down. Propeller pitch was then slowly reduced to zero so that maximum power was available for the blowers to give full tip-jet thrust.

Top: caption: “The Jet Gyrodyne making one of the early untethered flights at White Waltham in 1954”

Bottom: caption: “By September 1956 the Jet Gyrodyne had completed 190 transitions and 140 autorotative landings”



By September 1956, the techniques for transition were familiar and reasonably well understood. Thus, there was established a sound basis for the procedures required for the *Rotodyne* (which was to make its first flight a year later). That transition was not a difficult task was demonstrated by the fact that some half-dozen *Ministry of Supply* pilots each flew the *Jet Gyrodyne* successfully after about an hour's instruction and practice. Although scheduled for scrapping in 1961, the Jet Gyrodyne prototype (above) was rescued and preserved.

# Rotodyne



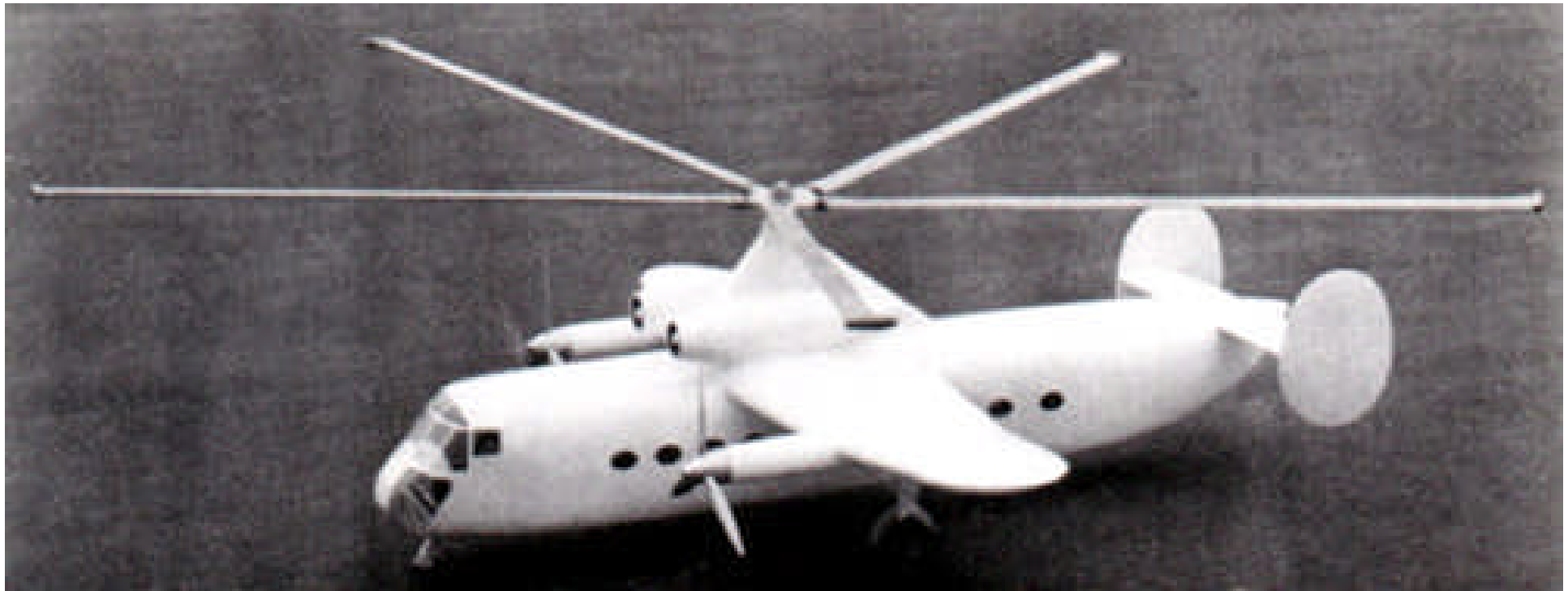

***“...The Rotodyne is a compound helicopter, able to fly in either of two modes. For VTOL it is lifted by a rotor driven by fuel-burning pressure-jet units at the tips of the blades, with the two propellers in approximately zero pitch to provide directional control. In translational (forwards) flight it is propelled by the two propellers, lift being provided by the fixed wing and by the rotor turning in autorotation. Originators of this scheme for a large compound helicopter were Dr. J.A.J. Bennett and Capt A.G. Forsyth, of Fairey Aviation, whose original study dates back to 1947. By 1950 the project had two Dart engines and 20 seats, but during the ensuing three years it grew to have three Mambas and 28 seats, two Darts plus two de Havilland engines and 40 seats, and finally two Eland engines and 40 seats. In 1959-60 the Rotodyne grew still further, and the FA-1, or Type Z, production aircraft was envisaged as having two Rolls-Royce Tynes and two Rolls-Royce RB.176 air producers, and a fuselage seating up to 70 passengers...”***

***FLIGHT magazine, August 9<sup>th</sup> 1962***

472

***Above: caption: “Scale model ca. 1952 of one of several Rotodyne proposals leading to the final design”***



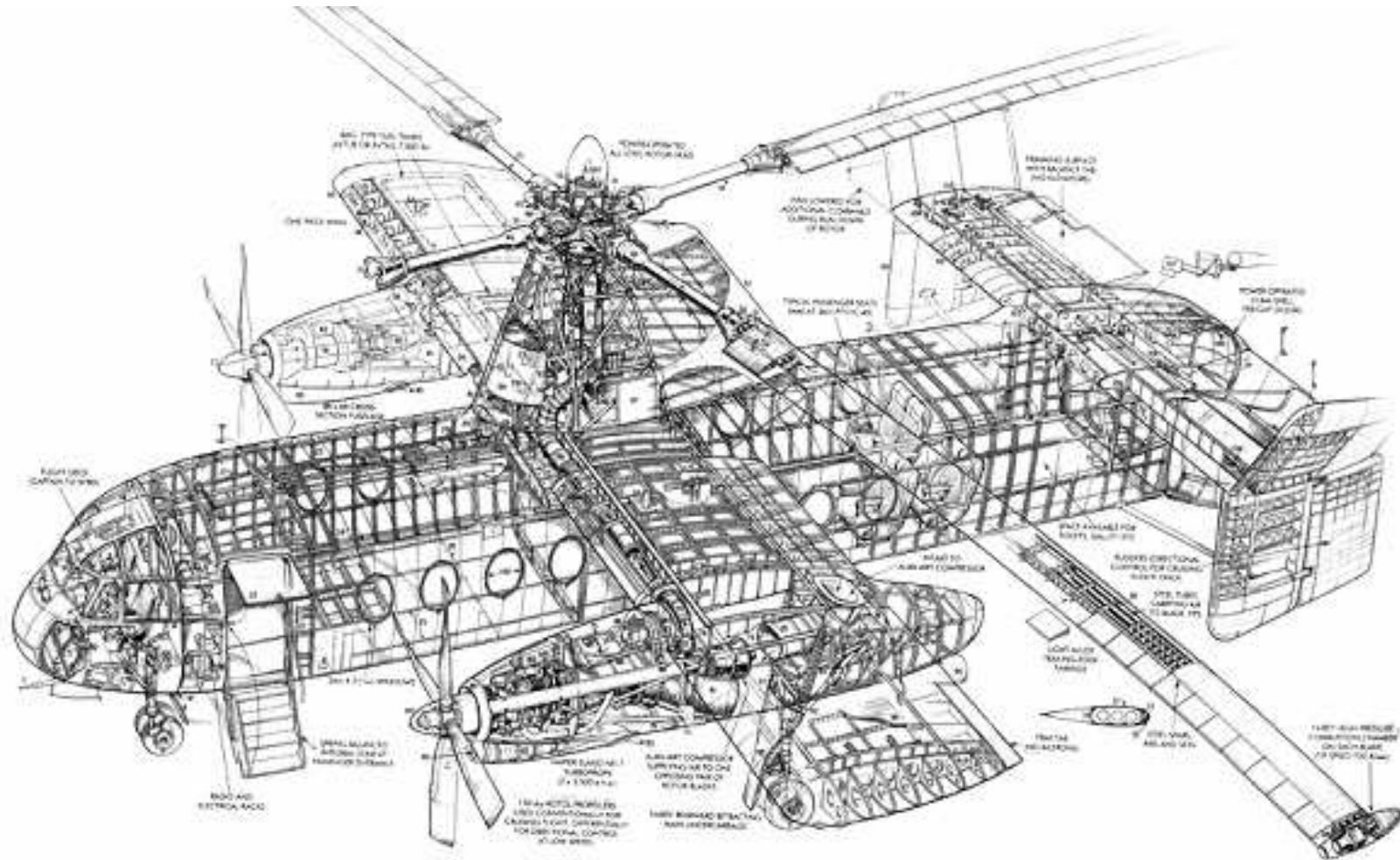

**Above:** caption: “Dimensions and weights: Fuselage length, 58ft 2in; height overall (to top of rotor head), 22ft 2in; fuselage interior, 46ft long, 8in. wide, 6ft high; floor height above ground, 3ft 2in; wing span, 46ft 6in; wing gross area, 475 Kg ft; rotor diameter, 90ft; rotor due loading, 6.14 lb/sq ft; rotor blade chord. 27in; Roto I propellers. 13ft diameter; tare weight, 24,030 lb [weight breakdown (lb): structure, 7,039; rotor system, 5,312: power plant, 7,364; fuel and air supply, 881; fixed power services, 1,987; safety measures, 279; equipment, 528; fixed furnishings, 640]: laden weight, 39,000lb (removable load, 1,797 lb; operating load, 6,273 lb; pay load, 7,400 lb).”

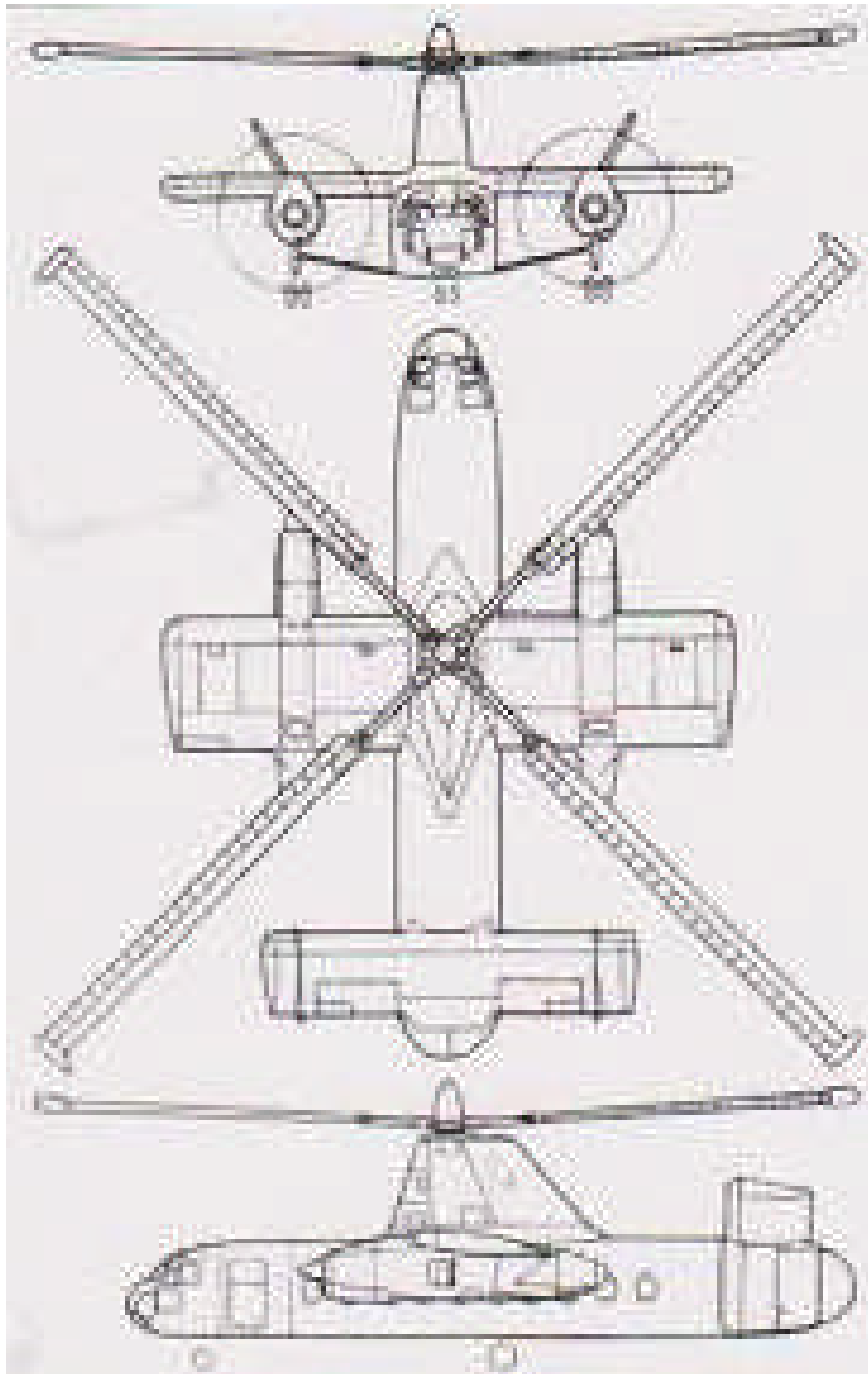

***“It may be our phlegmatic British temperament or it may be familiarity with the Gyrodyne and the Rotodyne models one has seen at Farnborough and Le Bourget. Whatever the reason, the fact that the Fairey Aviation Company are to fly the very first British convertiplane - a full-scale 40-seater - before the end of the year is not so readily appreciated as an event of this magnitude should rightly be. Moreover, in the writer’s personal opinion the configuration of the Rotodyne is by far the most logical and practical yet revealed...”***

***FLIGHT* magazine, August 9<sup>th</sup> 1957**

**Left: caption: “Basic performance (estimated): cruising speed, 170 mph: payload, 40 to 48 passengers for ranges up to 430 miles; vertical rate of climb at sea level at maximum power, 1,670 ft/min; direct operating cost per passenger mile, about 3 pence at 100 miles range, falling to 2 ½ pence at 250 miles<sup>475</sup> and 2.3 pence at 450 miles.**

# **The Principles**



***“...The Rotodyne is an extrapolation of the original Gyrodyne principle: power-driven rotor for vertical flight, with propellers for propulsion and autorotating rotor for forward flight. Where the Rotodyne differs from its predecessor is in having a considerable wing to share the lift with the windmilling rotor. The essential principles which led to this particular configuration require to be briefly stated for a proper understanding of the Rotodyne....”***

***FLIGHT*** magazine, August 9<sup>th</sup> 1957

***“...It was chosen firstly as being the best compromise to give VTOL ability with a practical cruising speed...The bane of the helicopter designer in search of speed has always been the stalling of the retreating blade, the true airspeed of which is the algebraic sum of the rotational velocity of the rotor and the forward speed of the aircraft. In other words, as aircraft speed rises the true airspeed of the retreating blade falls. Since there are practical limits to blade r.p.m. (imposed by centrifugal loading) and blade area (because of weight and drag) the only palliative for blade-stall is to reduce the loading and thereby the stalling speed of the critical inner portion. In the Rotodyne, at cruising speed, the wing carries 60 per cent of the load. Again, a propulsive rotor requires more incidence - and is, in any case, a device far removed from optimum efficiency in the horizontal plane, so that propellers are a logical corollary to an ‘off-loaded’ rotor...”***

***FLIGHT*** magazine, August 9<sup>th</sup> 1957

***“...Inevitably, a convertiplane must carry dead weight from one form of flight to the other - the wing and tail at take-off, the rotor drive while cruising. In the case of the Rotodyne, however, there is no cumbersome irreversible mechanism for the rotation of wing and/or rotors through ninety degrees, while there is some compensatory saving in the absence of a tail rotor. A single rotor was chosen by Fairey because of the greater reliability which it confers and because of the shorter time required to prove its reliability to licensing authorities. The tip-jet drive was adopted to simplify the transmission problems of a large rotor by the elimination of torque and gearing - 6,000 h.p. gearing in this case. As a ‘bonus,’ tip drive also makes drag hinges unnecessary...”***

***FLIGHT magazine, August 9<sup>th</sup> 1957***



***“...The pressure jet is, of course, noisy - it is, in effect, an afterburner - but even unsilenced is rather less cacophonous than a ramjet or pulsejet of similar thrust. One imagines that the noise will be of little trouble to the passengers, for it will last only three or four minutes at each end of the flight and, in any case, they are insulated from it. Fairey are, too, doing much work on noise reduction on an ad hoc basis. The latest sixteen-slot nozzle makes a reduction of 10 decibels over the plain one, which is equivalent to no more than 10 per cent of the original volume. The main task now, according to Dr. G.S. Hislop (chief designer, helicopters) is to concentrate upon developing this new engine to the pitch of reliability of old-established types....”***

***FLIGHT*** magazine, August 9<sup>th</sup> 1957

# **Airworthiness Aspects**

***“...An aspect which is liable to be overlooked is that there are as yet no airworthiness requirements for convertiplanes. Fairey therefore followed the principle which had led to the Rotodyne being designed as a full-scale usable article and not simply as a research aircraft...everything possible is being done to evolve a true commercial vehicle with safety standards in line with current airline practice...”***

***FLIGHT*** magazine, August 9<sup>th</sup> 1957

***“...It appears that the Rotodyne will become an ‘aeroplane’ soon after it develops forward speed, for the model characteristics are linear after some 40 ft/sec right up to 400 ft/sec. It should be noted here that there is an essential difference even between the modified Jet Gyrodyne and the Rotodyne, because the stub wing of the former carries no appreciable load and, in fact, the rotor cannot maintain level flight in autorotation. Thus, there are definite limitations to the knowledge to be gained from that research aircraft...”***

***FLIGHT*** magazine, August 9<sup>th</sup> 1957

# **Flight Characteristics and Control**

***“...The Rotodyne will, essentially, be controlled as a helicopter; that is, the stick gives cyclic pitch and the throttle is a twist-grip on the collective-pitch lever. The rudder pedals operate the rudders and also superimpose differential pitch-change on the propellers to give yaw control. At present, the elevators are electrically operated (by a button on the stick) for trim only, and there is a large trimming tab on the port wing...The rotor is the sole control in roll and pitch and would continue to be available even in the case of both engines stopping, since it drives its own emergency hydraulic supply. The large ‘elevators’ have balance-tabs to relieve hinge moments and so assist their electric screwjacks, but they are, nevertheless, purely trim surfaces. They have, however, been designed for use as elevators should this prove desirable. Likewise, ailerons can be fitted should these be thought preferable for cruising conditions...”***

***FLIGHT*** magazine, August 9<sup>th</sup> 1957

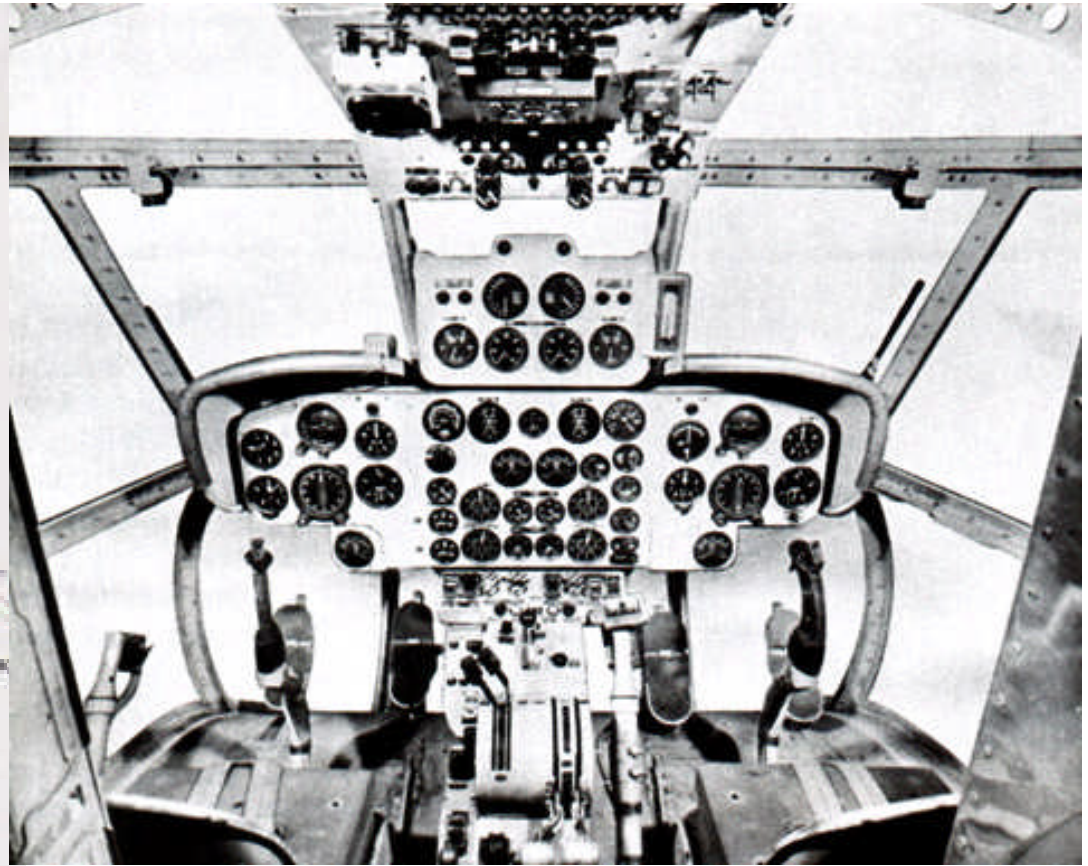
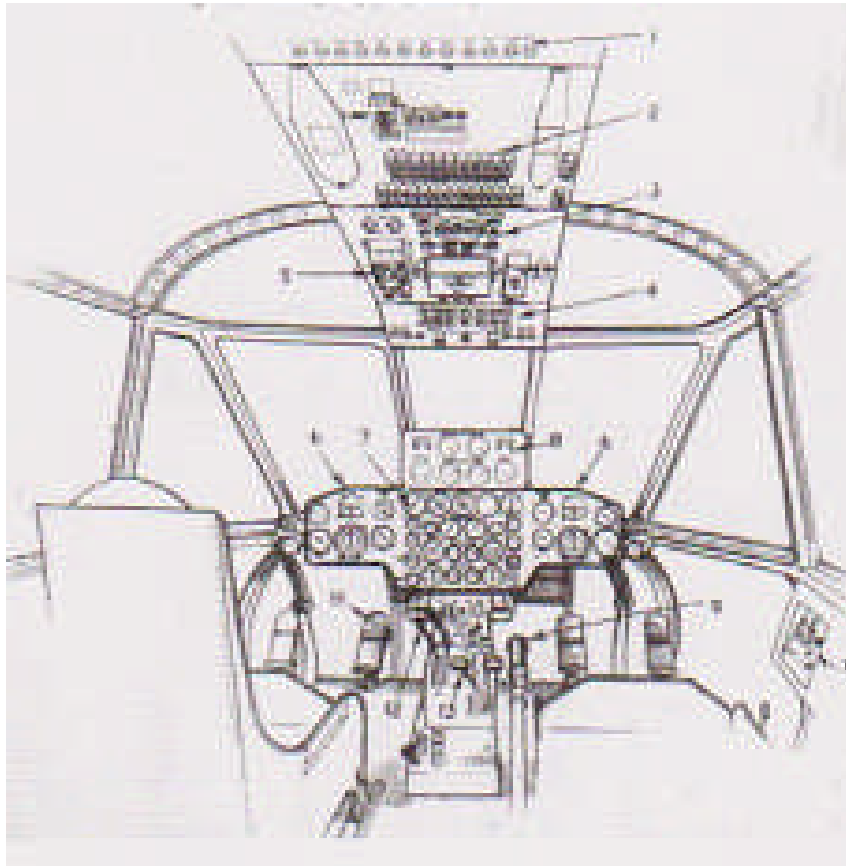

**Left: caption: “Cockpit layout: 1, fuse panel; 2, circuit breaker; 3, fuel system; 4, warning lights; 5, G.M. Mk 48 compass control panel; 6, flight instruments; 7, engine and auxiliary instruments; 8, engine transition panel; 9, collective pitch control (dual on port side); 10, screen-wiper control; 11, toe brakes; 12, propeller pitch control levers; 13, power levers.”**

**Right: caption: “The control-cabin of the Rotodyne. As with other helicopters, the first pilot flew from the right-hand seat. Except for the rotor revolutions indicators and low-speed-range ASIs, the flight panels carried normal fixed-wing instrumentation.”**

***“...The yaw control is a melange of rotating and fixed-wing practice. Above a forward speed of 80 kt the rudders alone control the aircraft in yaw. They are actuated by Fairey Hydroboosters, not because of large loads but because wind-tunnel results suggested that during hovering in a side-wind there would be feed-back of a beat from the rotor downwash. Below 80 kt, progressively more differential propeller-pitch control is introduced to replace the rudder moment, which gradually falls off with speed although the rudder surfaces retain full movement all the way...Evolution of the yaw control has occupied more time than any other detail on the aircraft. The work has been a joint effort by Fairey, Napier and Rotol...”***

***FLIGHT*** magazine, August 9<sup>th</sup> 1957



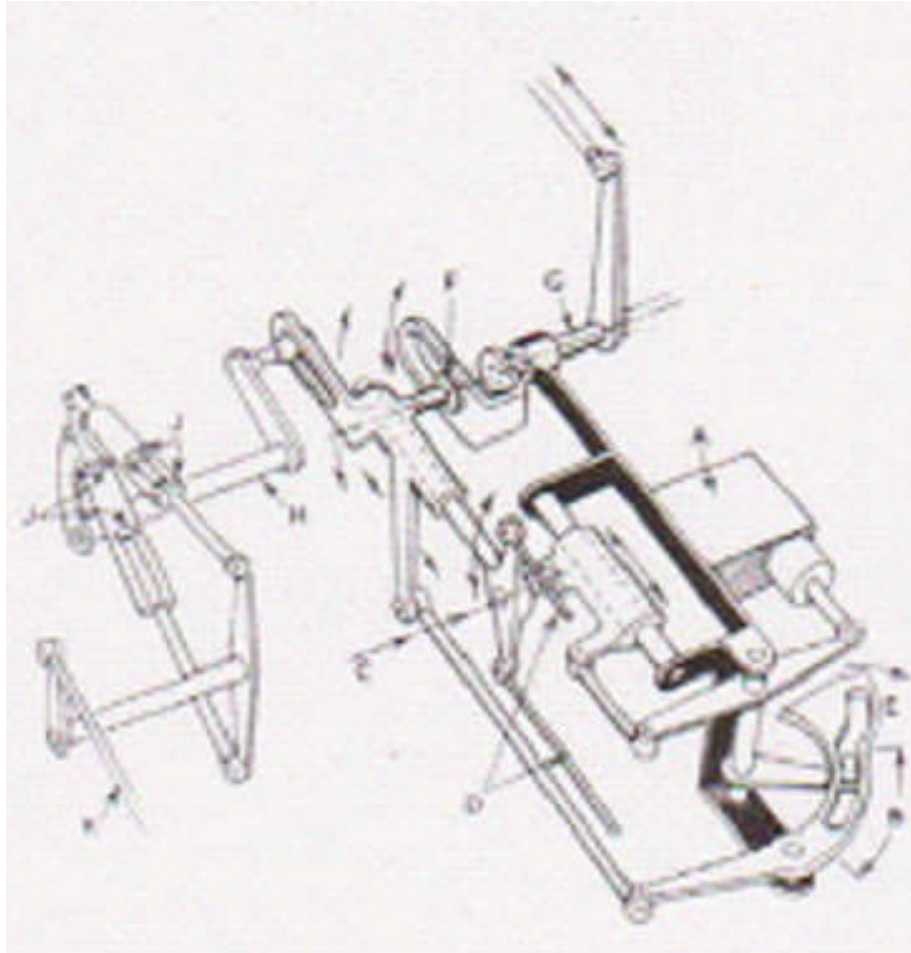

**Left: caption: “Integration and change-over of rudder and differential pitch shown diagrammatically. Operation of actuator in cruising-pitch conditions moves lever through the ineffective sector of cam-track also moving slide carrying the pivot operating the pitch-control rods D collectively. Further movement of actuator, out of cruise condition, moves lever to effective sector of cam-track E. The resulting displacement of cam and associated linkage displaces roller F from neutral position on center line of rudder movement input shaft G. Rudder movement then swings roller F and its carrying arm about pivot C, moving pitch controls D differentially. Movement of roller F by rudder action rocks shaft H, which (via butting stops) imparts a unidirectional movement to K, limiting the auxiliary compressor output.”**

***“...There is, too, that vexed question of the rotor downwash on the fixed surfaces when hovering. Downwash velocity is graded steeply toward the blade tips, owing to their higher airspeed, and it appears that little of the Rotodyne’s horizontal surface area is in the critical zone. Estimates varied between 3 per cent and 6 per cent, so 4.5 per cent was allowed for - and was almost exactly confirmed by the tunnel tests. Conversely, it seems that the downwash creates a positive pressure lift from the wing during hovering in the ground cushion...”***

***FLIGHT*** magazine, August 9<sup>th</sup> 1957

# De-Icing

***“...The actual form of blade de-icing remains to be decided, as there are some years of testing ahead before it will actually be necessary, during which time some definitive version may have been developed. In any case, the electrical power is there, ready for anything. Incidentally, it is worth recalling that, as the maximum tip-speed is 720 ft/sec (almost 500 m.p.h.), anything attached to the blade surface would – literally - take a beating...The apparently obvious method of de-icing the rotor blades by compressor air, since it is delivered at over 250 deg C, is in fact a delusion. In the first place the three delivery ducts are not adjacent to the rotor blade skin; in the second, considerable power would have to be provided to drive the auxiliary compressors, so that a prohibitive fuel allowance would have to be made for de-icing...”***

***FLIGHT*** magazine, August 9<sup>th</sup> 1957

# Rotor

***“...improvements were progressively made to the hub. This massive steel assembly is built up around the ducts leading to the two pairs of blades, and constant effort was made to eliminate joints in order to minimize fatigue problems (and reduce weight). The FA-1 hub would have been a single S.99 forging with the flapping hinges moved inwards from 24in to 20in from the axis of rotation despite an increase in rotor diameter from 90 ft. to 109 ft. The inner spar would have been a single component out to a radius of 14ft, with an integral end-fitting. Frontal area becomes of considerable importance at speeds greater than 200 m.p.h., and the main swash plate was moved below the hub and inside the pylon. The FA-1 would have had a fully faired hub, with a lightweight casing extending out along the inner spars. Considerable development also took place in the field of bearings, and it is noteworthy that the taper-roller feathering bearings of the FA-1 would have been lighter than those of the Y...”***

***FLIGHT*** magazine, August 9<sup>th</sup> 1962



***“...This is essentially an all-steel structure (to overcome the fatigue-life problems associated with high-strength light alloys), considerable resort being made to nickel alloys in the combustion and compressed-air-delivery zones...”***

***FLIGHT* magazine, August 9<sup>th</sup> 1957**

**Above: caption: “Preparing the rotor head for one of the many test programmes; this picture gives a vivid idea of its size”**

# **Rotor Blades**



***“...From the outset the rotor has been an all-steel assembly. The four blades of the Y are built up like an aeroplane wing, but the riveted jointing throughout the blade drastically restricted the allowable operating stresses. It was considered that, while welding might have offered a slight improvement, the real cure was to eliminate all joints in highly stressed regions. A single duct blade was eventually devised, consisting of upper and lower stainless-steel machined forgings bolted together in regions of low stress, with integral root and tip joints. Test specimens suggested that the allowable stress could be several times that of the original blades, but the long forgings were difficult and expensive to produce. Since each blade had to transmit a large flow of compressed air the ideal spar appeared to be a hollow seamless section, similar to that used on the Ultra Light Helicopter six years earlier. Consequently Fairey discussed the possibility of a hollow seamless section with various manufacturers, including the aircraft division of Parsons Corporation, Traverse City, Michigan, the largest manufacturers of rotor blades in the world. Parsons were given a challenging specification for a seamless tube more than 40 ft. in length, produced in high-strength steel with a variable wall thickness held to within three thousandths of an inch. No plant was in existence capable of producing a component of the type specified; but Parsons realized that the expenditure needed to acquire the ability to make such a component could be an investment for the future...”***

***FLIGHT magazine, August 9<sup>th</sup> 1962***

**World's highest rate of climb**

**Precise Control**

**Negligible Maintenance**

no specialist ground crew

**Assembles in minutes**

survives rough handling

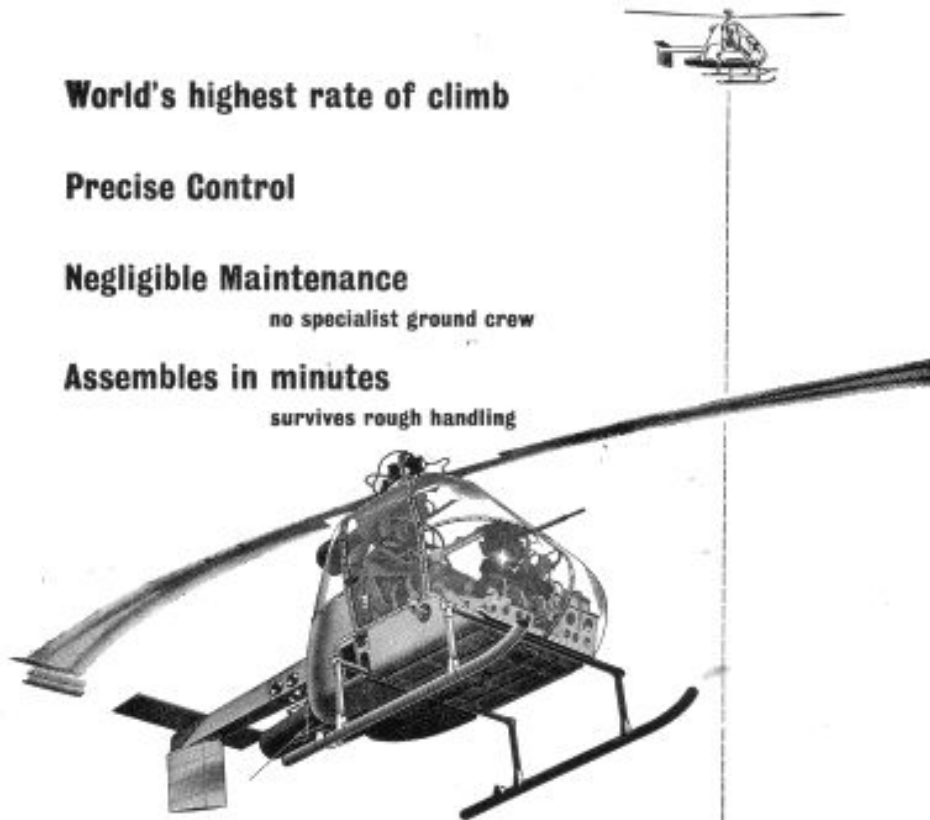

The **FAIREY** Ultra - Light

# MILITARY HELICOPTER

One three ton truck carries the helicopter, pilot, fuel and spares, and functions as a deck for landing and take-off, forming an entirely self-sufficient mobile unit.



THE FAIREY AVIATION COMPANY LIMITED · HAYES · MIDDLESEX  
ENGLAND AUSTRALIA · CANADA



*"...Each 45-ft rotor blade is a two-piece unit – the aerofoil structure and the inner spar (in this connection one regards the combustion chamber as a separate entity, even though it has a considerable influence upon the blade structure). The blade aerofoil is a symmetrical one of low drag, but not laminar flow. Because of the great importance of fore-and-aft c.g. position on flutter, the blade is designed with a solid steel leading-edge and very thin light-alloy trailing-edge...Down the interior of the blade run the three Accles and Pollock air-delivery tubes of T.58 steel, each in one piece..."*

*FLIGHT* magazine, August 9<sup>th</sup> 1957

Above: caption: "A rotor-blade root, showing reinforcing skin laminations, attach-ment fittings, fuel pipe in leading 497 edge, and the trifurcated air-duct union"

Left: advertisement for the Fairey Ultra-Light helicopter

# **Rotor Mountings**

***“...The rotor is carried on a bolted H.T. steel-tube (T.60) four-legged ‘tower.’ The streamlined fairing round this structure is anchored only to the four fuselage fittings for the ‘tower,’ otherwise it is fully floating so as to allow for strain in the tubular structure. On the top of the tower are four pairs of triangulated tubes, the four apices of which carry the main bearing housing. This last is a 30-in diameter circular channel boxed on its underside by a bolted steel plate...”***

***FLIGHT*** magazine, August 9<sup>th</sup> 1957

# **Air Delivery**

***“...The air from each Eland feeds only one pair of (opposing) rotor blades, so that in the event of engine failure the efficiency of the system is not impaired. The leading-edge air ducts are fabricated by spot welding from Nimonic 75 sheet, using a crimped, or bellows, form to allow for thermal expansion. When the ducts reach the rotor pylon there is the problem of maintaining separate delivery into the rotating head. To achieve this a light alloy casting, known not unnaturally as the ‘breeches pipe,’ accepts the two air flows in its ‘legs’ and delivers them through concentric annuli which feed into the ‘milk churn.’ This is a fabricated Nimonic sheet assembly reminiscent of a Coles chimney cowl...”***

***FLIGHT magazine, August 9<sup>th</sup> 1957***

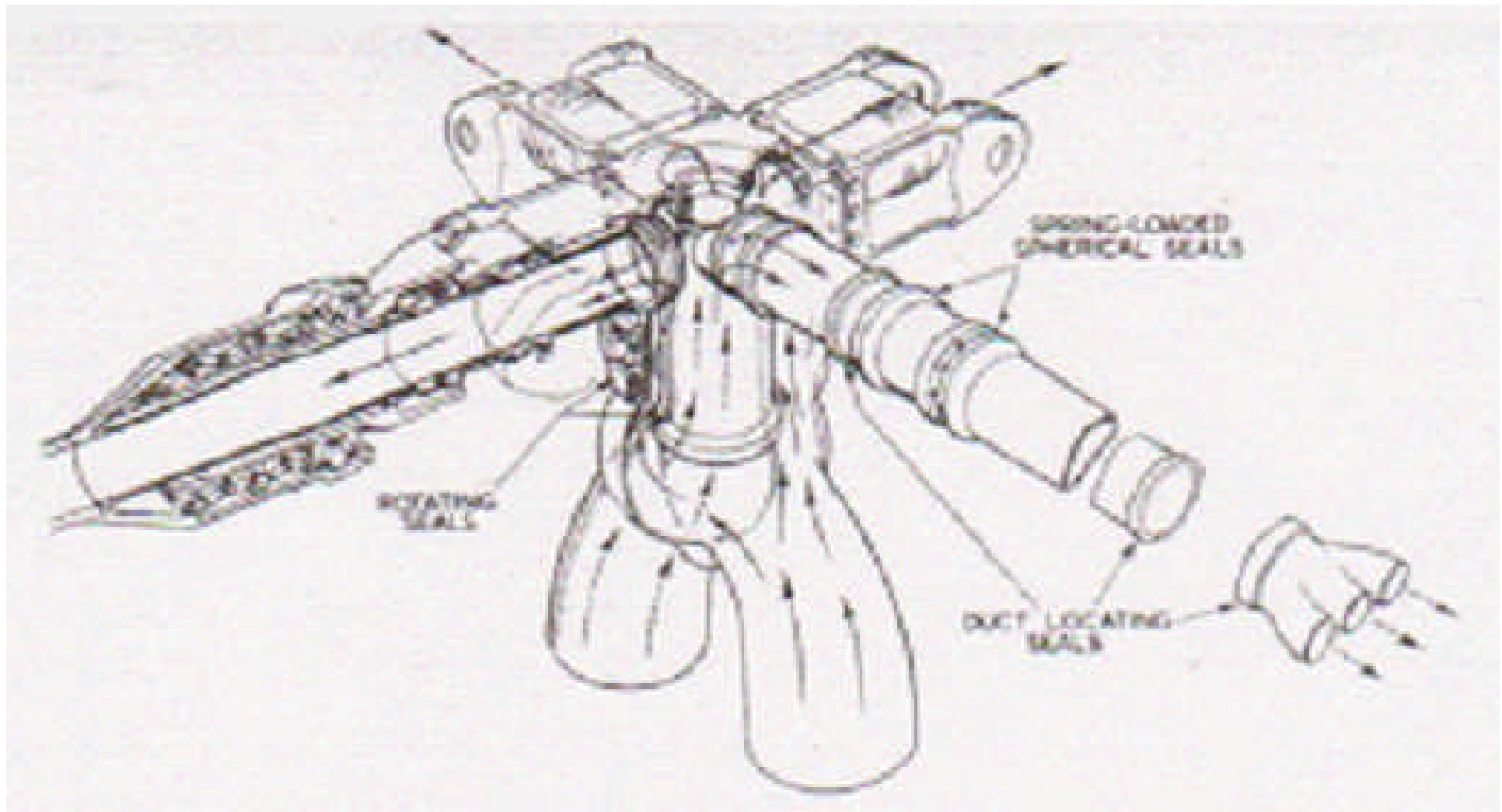

**Above: caption: “Air from the port auxiliary compressor enters the inner duct of the light-alloy ‘trouser’ casting and the starboard compressor supplies the annular duct around it. The sketch also indicates some of the sealing problems involved in leading pressurized air at 250 deg C through flexing ducts. Note also the spar-root taper roller bearings.”**



***“...The ‘churn’ is a concentric annular duct mounted in the rotating rotor-hub which ingeniously delivers the air from each duct to opposing pairs of blades. With the help of cascades to turn the flows and careful matching of cross-sectional areas the duct losses have been kept low. The rotating joint between the ‘breeches pipe’ and the ‘churn’ is sealed by a graphite-impregnated sintered bronze ring. Dividing the two flows - normally without a pressure drop, but vital after engine failure - is a labyrinth seal. Up the center of the assembly is the airtight tube within which the concentric control tubes operate; and at the center of everything is the conduit for fuel pipes and ignition leads...”***

***FLIGHT magazine, August 9<sup>th</sup> 1957***

***Left: caption: “The ‘milk churn’ fabricated from sheet, which ducts air to opposing blade-spar roots”***



# Rotor Head

***“...The basic problem in the rotor head was how to get the pitch-change controls round the obstruction offered by the air ducting. It was solved by mounting the actuating linkages and swashplate on top of the rotating head, with the operating jacks anchored below the main bearing housing, the action being transmitted by concentric slide/torque tubes...”***

***FLIGHT*** magazine, August 9<sup>th</sup> 1957

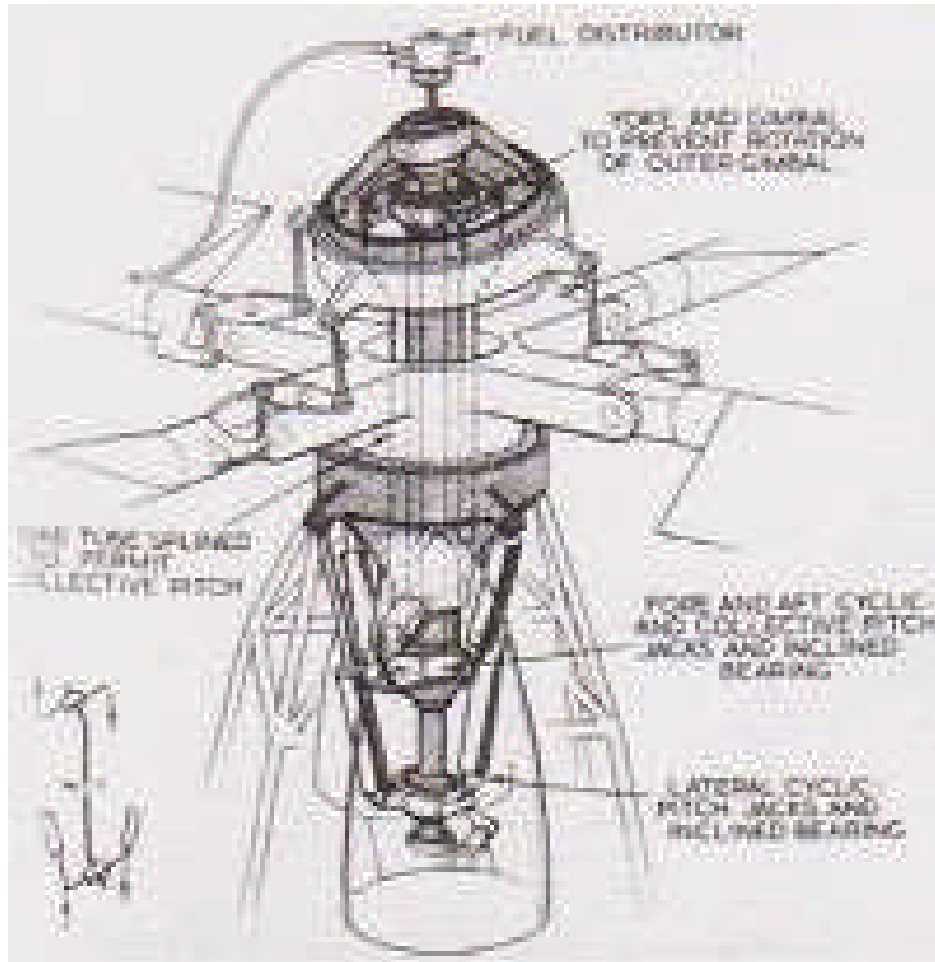

**Left:** caption: “Rotor pitch control (airflow omitted for clarity): Rocking movement applied by paired jacks to the lower set of inclined bearings on the concentric control tubes imparts a rotary motion to the vertical tubes and a corresponding rocking of the upper set of inclined bearings, thus tilting the spider. Collective pitch is obtained by both upper jacks moving in the same sense. The inner tube is splined to allow this vertical movement of outer tube and spider. Small diagram shows principle of inclined bearings.”

***“...The two pairs of control jacks - with tandem pressure chambers fed continuously by main (duplicated) and emergency hydraulic supplies - act on sliding collars mounted on hemispherical bosses on the actuating tubes. The upper collar rotates the outer of the two control tubes to displace, through its canted head, the fore-and-aft cyclic-pitch linkage, while the lower one similarly operates the lateral cyclic-pitch linkage through the inner tube. The two ‘fore-and-aft’ jacks operate together to raise and lower the swashpalte (which has a driving link to one rotor-blade stub arm only) to give collective pitch change. A splined extension at the foot of the operating tube allows vertical displacement for collective pitch control without affecting the lateral cyclic-pitch jacks...The central tube to the top of the rotor head carries a conduit containing the fuel lines, ignition leads and light-up telltale leads to the fuel distributor manifold and respective sliprings...”***

***FLIGHT*** magazine, August 9<sup>th</sup> 1957

# Tip Jets

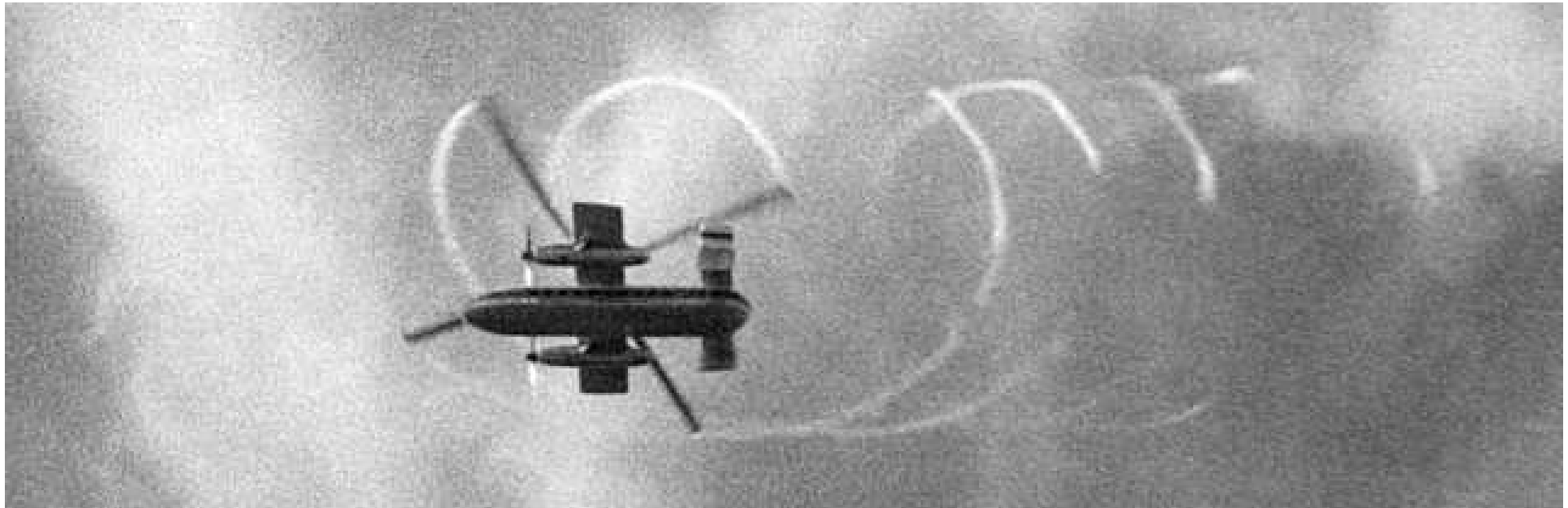

***“...The tip-driven rotor is fundamental to the concept. Especially with rotary-wing aircraft of the largest sizes, it is lighter than a geared drive to the hub; but it also has a higher fuel consumption, and so in the Rotodyne was used only for VTOL. Many types of tip drive are possible. The simplest employ tip-mounted rockets, ramjets or pulsejets, but these suffer from inordinate specific consumption. Pressure-jet units may be employed either with or without combustion at the tip of the blade. Without combustion the required duct area makes the rotor aerodynamically unsuited to high-speed operation, and this type of system is likely to be applied only to cranes and other slow-flying craft. With tip-combustion, rotor horsepower for a given flow through the blade is enormously increased, and there seems no reason to doubt that the Rotodyne rotor was the most efficient that could possibly be devised...”***

***FLIGHT*** magazine, August 9<sup>th</sup> 1962

***Above: caption: “Tip Jet restart “***

***“...Like most aeronautical design problems, a tip-driven rotor is the end-product of a series of compromises. The blade profile must be the optimum aerodynamically; the duct must be accommodated wholly within this profile; the c.g. must be located at not more than 25 per cent chord; for peak efficiency, pressure ratio must be correctly chosen; tip speed is limited by Mach number; ideally, jet velocity should be not greater than twice the rotor tip speed, but this would take the size of the duct outside the blade profile; each pressure-jet unit becomes pure drag and weight in cruising flight; noise from such a rotor may be severe, and of an unfamiliar character; and means must be found to provide for engine-out operation...”***

***FLIGHT magazine, August 9<sup>th</sup> 1962***

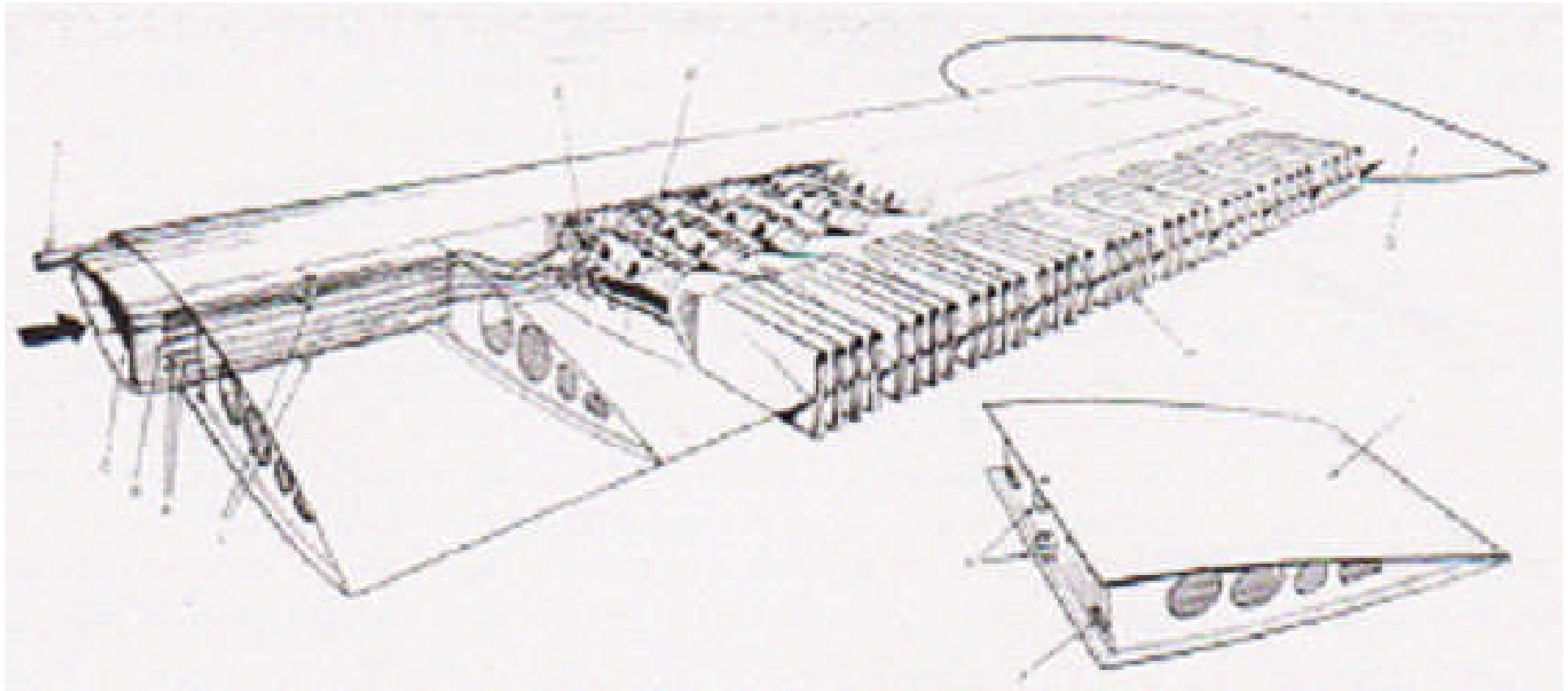

**Above: caption: “This sketch indicates the general design of the two-dimensional form of nozzle proposed for the ultimate civil aircraft: A, ignition leads; B, fuel pipes; C, hollow spar forming air duct; D, balance weight in plastics leading edge; E, air entry to combustion chamber; F, flame tube; G, tip fairing and balance weight; H, silencing nozzle; I, light-alloy trailing edge section; J, fluon rubbing pad; K, attachment lugs; L, anchorage on strip brazed to spar”**



***“...Complication is introduced by the need to provide for engine-out operation. If two sources of compressed air were connected to a single pipe serving all four blades, loss of either source would result in unacceptable loss in rotor horsepower (much more than 50 per cent). The Rotodyne rotor operated as two opposite pairs of blades, each served by one of the sources of compressed air. Termination of the supply from either source was automatically countered by increasing the fuel flow to the remaining pair of pressure-jet units, thus restricting the drop in rotor horsepower to below 13 per cent. At maximum weight, this enabled a satisfactory VTOL landing to be carried out. But this could be achieved only by designing the pressure-jet units for severe combustion conditions...During 1960 it became obvious that a switch would have to be made to the Rolls-Royce Tyne...Eventually Rolls-Royce suggested separate air-producing engines...”***

***FLIGHT*** magazine, August 9<sup>th</sup> 1962

***“...the BEA Type Specification stipulated an initial climb at zero forward speed at maximum weight not less than 600ft/min with a sound pressure level 600ft from the rotor axis not exceeding 96db. Ignoring the noise requirement for the moment, this meant that each of the two pairs of blades had to generate 3,850 h.p. with an airflow of 33lb/sec and a fuel/air ratio of 0.04. The specific consumption was approximately 1.85lb/rotor h.p./hr. It was a requirement that the aircraft should be able to hover at maximum weight with either engine inoperative and the other at 2½ min max contingency of 7,390 h.p. (with water/methanol). The remaining engine would feed only one pair of blades, and could provide a maximum airflow of 43lb/sec...emergency power to the rotor was achieved partly by an increase in engine power without water/methanol injection to max contingency rating, but mainly by an increase of tip-jet combustion temperature corresponding to an increase in fuel/air ratio from 0.02 to 0.065...”***

***FLIGHT*** magazine, August 9<sup>th</sup> 1962



**Above & Left: caption: “The Fairey Rotodyne “Y” convertiplane, which could take off and land as a helicopter and fly as an autogyro, in a test flight during 1957-1962. It could carry 40 passengers and a crew of two and cruise at 200 mph.”**

# Vibration



***“...The prototype Rotodyne Y (XE521) first flew on November 6, 1957. Prior to that date the most feared problem had been ground resonance; and the aircraft was originally built with a temporary fixed undercarriage. Extensive research eventually led to a retractable undercarriage with very soft characteristics, which enabled the existing structural damping of the rotor and fuselage to be more effective. It was also found that gusts were causing the blades to oscillate at their natural frequency, and a cure was found by introducing a damper in a strut behind the steel tube which formed the inner part of the blade...”***

***FLIGHT* magazine, August 9<sup>th</sup> 1962**

**Above: caption: “The Rotodyne being assembled at White Waltham in May 1957. The retractable undercarriage was replaced by a fixed gear for the earlier flights, following ground-resonance tests”**



**Above: caption: “This picture of the Rotodyne, on one of its first flights, shows the massively struted fixed undercarriage which, pending redesign, replaced the retractable gear for the early tests”**

***“...When the aircraft was built, there was in Britain a dearth of knowledge of the precise loading experienced by a rotor. Without knowing the basic rotor forces the magnitude of the various harmonic contents could not be calculated, and this in turn made it impossible to design the airframe to avoid significant rotor-induced vibration. Once the aircraft got into the air it was appreciated that the oscillatory loads induced by the rotor were sufficiently large to make knowledge of body vibration characteristics important, if only to alleviate pilot discomfort. Two main conditions had to be investigated: high-speed cruising flight as an autogiro, and flare-out as a helicopter. Rotor r.p.m. were approximately 120 in the first case and 140 in the second, so that the loads induced by the rotor came through at different frequencies. The airframe can vibrate in a whole gamut of modes and frequencies - body hogging, pylon forward, wings up, and so on. The various body frequencies lie so close together that it is hardly surprising that one mode was found to occur very close to each of the two critical values of rotor r.p.m...”***

***FLIGHT*** magazine, August 9<sup>th</sup> 1962

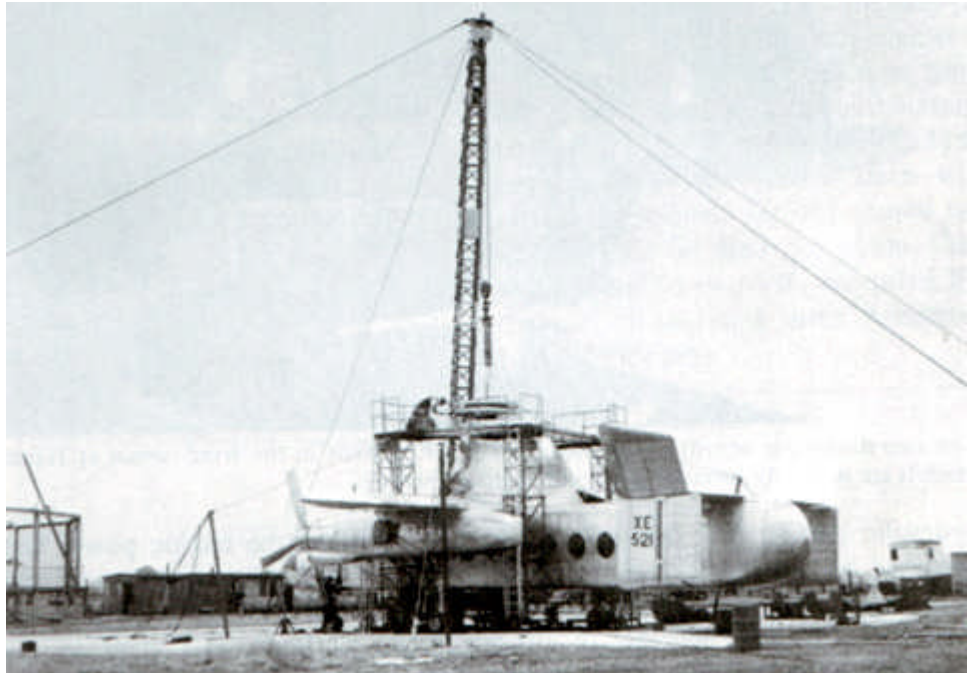

**Left: caption: “Resonance tests of the Rotodyne were made at White Waltham with this rig, in which partially airborne conditions were simulated by a crane and the airframe was shaken by hydraulic jacks on the rotor pylon”**



***“...Resulting from extensive calculation and dynamic model experiment, airframe modifications were introduced to demonstrate that the structure could be altered to remove the troublesome frequencies from the running r.p.m. range. The mode in the vicinity of 120 r.p.m. responded to pylon fore and aft stiffnesses, and a reduction of these stiffnesses, coupled with a flexible tailplane mounted with dampers, completely cured the trouble. The mode in the vicinity of 140 r.p.m. was modified in a more dramatic way by the addition of a large strut from the top of the pylon to the tail, which served to show that a much smoother ride would result when the practicable airframe stiffnesses were suitably modified...”***

***FLIGHT*** magazine, August 9<sup>th</sup> 1962



**Above: caption: “Powerplant and rotor-drive testing before the first flight of the Rotodyne, in November 1957, involved some 50 hours of rotor and 100 hours of engine running”**



***“...The alleviation of vibration was a continuous job through a host of tests, some with applied modifications and some for gathering data only. In early flying the cockpit suffered from severe tray resonance in the classic helicopter vibration conditions, but by the end of development all 4th-rotor (which was the only frequency of note) had been eliminated, and the only complaint pilots could make was of a propeller-frequency ‘buzz’ on the instrumentation boom...”***

***FLIGHT* magazine, August 9<sup>th</sup> 1962**

**Left: caption: “Recording and other gear in the Rotodyne for the first flights, as seen from the rear of the fuselage”**

**Right: caption: “The test-rig for the powerplants, compressors and rotors of the Rotodyne at Boscombe Down. ‘Flying’ started in April 1957 with one Eland powerplant and compressor and a two-blade rotor, with balancing dummies<sup>522</sup> in place of the other two blades”**



***“...In the final vibration-modified state, lag-plane dampers had been fixed to the blade ‘lamp post’ stub arms, fin-weights and tail-plane damper-struts were fitted, and a flexible pylon structure installed, and in this condition the vibration standard in the passenger cabin was brought to within the BEA comfort criteria. All vibration reduction was achieved with no stiffness modifications to the main fuselage, and the design information gained for a tuned structure was enough to guarantee a low vibration level on the production aircraft...”***

***FLIGHT magazine, August 9<sup>th</sup> 1962***

***Above: caption: “Among many tests in the vibration programme for the Rotodyne was one in which the empennage was removed and a strut fitted between the rotor pylon and tail to measure changes in stiffness***

# Noise

***“...Noise from the rotor was severe, and the problem was rendered acute by the fact that it was of an unusual ‘chuffing’ character. Intensive work on the problem began in mid-1956, but the effort was accelerated owing to both the increase in rotor power and the stipulation of an agreed level for civil operation. In fact, the actual noise of an unsilenced unit at 600ft was approximately 113db. To achieve the 17db reduction demanded for civil operation would have necessitated a redesign of the pressure-jet into a two-dimensional form occupying the last 48in of each blade. It was expected that the final unit would have nine circular flame tubes within a combustion chamber submerged within the blade profile. These liners would have been interconnected, with an igniter plug at each end of the chamber, and the exit nozzles would have been fabricated from molybdenum with a diffusion-deposited Si-Cr layer to prevent oxidation. This process required special furnaces which are only now becoming available in this country...”***

***FLIGHT magazine, August 9<sup>th</sup> 1962***

***“...Much ill-informed criticism was leveled at the subjective noise at take-off and landing with tips lit. The attenuation programme had in fact produced reductions down to 96db by the time the development contract was cancelled. A point which most critics failed to appreciate was that the tips-lit time in service was only going to approximate one minute at take-off and at landing, and, with the flight profiles evolved, low-frequency subjective noise levels for such short periods would have been unlikely to cause annoyance. The flight paths for safety and minimum noise nuisance were to be: a vertical climb at take-off to 250ft, before accelerating in forward flight through a point 600ft above the heliport at 600ft from the pad; and a standard approach angle of 15° for landing. Further large benefits in noise attenuation were envisaged to come from proper heliport design. To prove some of these points with this under-powered partially-attenuated prototype, we made two flights over London and into the Battersea Heliport on a dead calm morning, and no complaints were raised...”***

***FLIGHT*** magazine, August 9<sup>th</sup> 1962

# **Control and Stability**



***“...lateral control was entirely through lateral cyclic and this became progressively less effective with forward speed as rotor r.p.m. was progressively reduced. Coincidentally, the sloping upper fins with their dihedral effect introduced a cross-coupling in lateral/directional control which was quite unacceptable. The first modification here was to make the upper fins vertical, and this cured the worst of the rolling tendency with yaw. In the wing-incidence change, ailerons were fitted and linked directly to the lateral-cyclic control at all times, and the combined effect of these, with the vertical fins, was to give normal aeroplane rolling control and response in the cruise regime, together with an absolute minimum increase in rotor flapping during the most violent rolling manoeuvres. Later, to overcome some low-angle, low-frequency directional oscillations of about 2° each way, a third upper fin was added and yaw stability characteristics were then considered adequate for the full manual case, without auto-stabilization. Work in this area was vital to the 70-passenger version, since the configuration of that aircraft was to be irrevocably similar to the prototype, and therefore suffered from the same short tail-arm, and a limited fin aspect-ratio to meet the rotor droop and flapping cases. In the final design for the production aircraft, four upper fins were incorporated...”***

***FLIGHT*** magazine, August 9<sup>th</sup> 1962



**Top:** caption: “The Rotodyne, XE521, made its first flight on 6 November, 1957, in helicopter mode and without the folding upper fins”

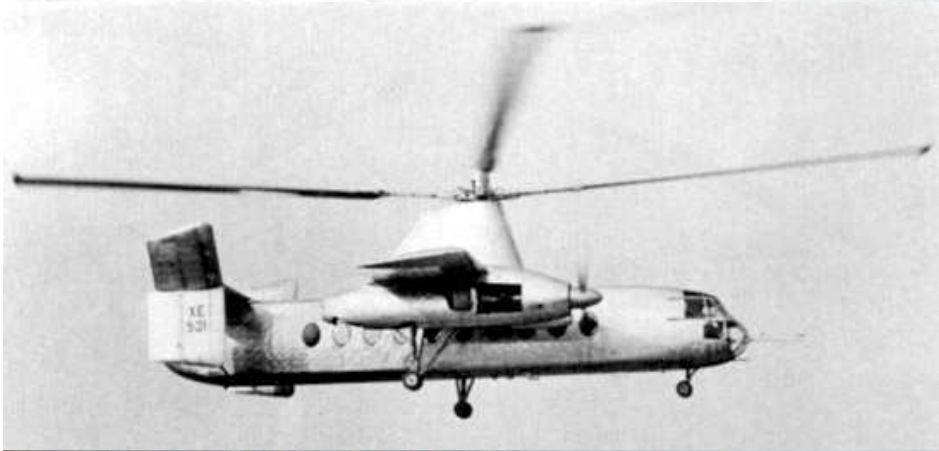

**Middle:** caption: “The Rotodyne with folding upper fins now fitted, but still in 'raw' prototype finish”



**Bottom:** caption: “The Rotodyne in 1959, with the folding upper fins now vertical and with the undercarriage retracted. Early in that year it had broken the closed-circuit speed record in the convertiplane class.”

# **Requiem for the Rotodyne**

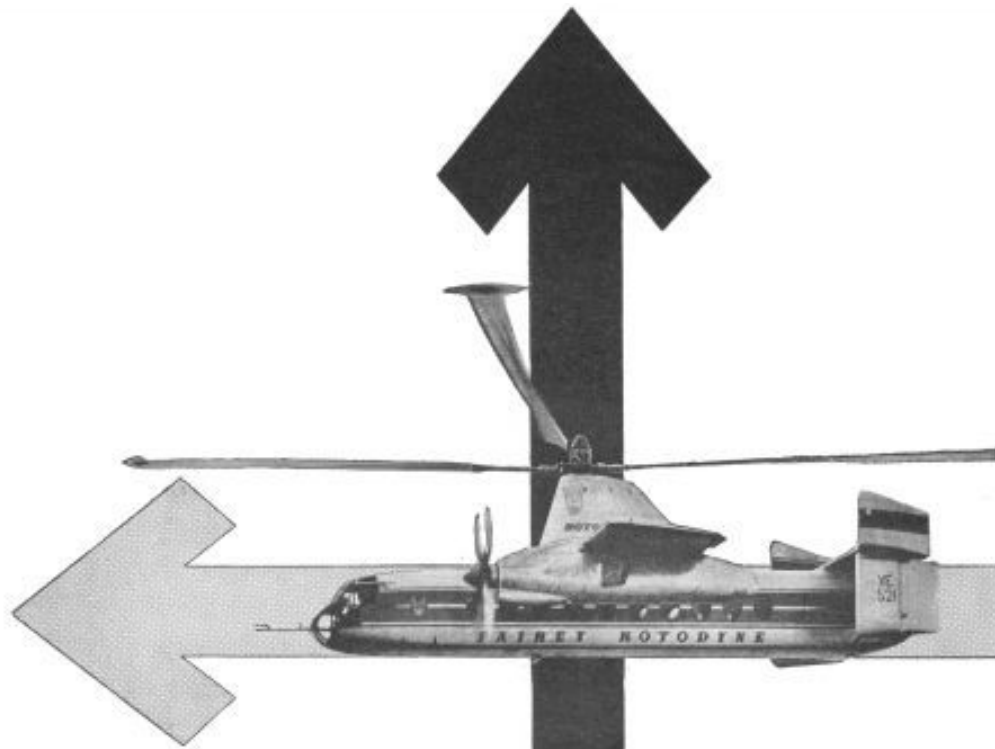

LOOK FORWARD TO  
**ROTODYNE**  
**TRAVEL**

The  
first  
vertical  
take-off  
airliner

***“In 1956 it seemed to many people, including many with expert knowledge of aeronautics, that the Rotodyne was something with a potential which could possibly bring striking new developments in air transport and air communication.”***

RE: excerpt from a speech given by a *Member of Parliament* (MP) during a debate on the aircraft industry (in 1962). At left, an advertisement for the *Fairey Rotodyne* from 1959.

## LOOK FORWARD TO **Rotodyne** TRAVEL

This is how people will go from city to city, when we have Rotodyne travel. Forty-eight people will settle themselves in the wide, comfortable cabin of the Fairey Rotodyne, at some small open space in the middle of a town. The Rotodyne will lift them vertically far above chimney-smoke and church spires—and then, gradually transferring the power of its two turbine engines from the big rotor to the forward propellers, it will whisk them across land and water at nearly 200 m.p.h. Over the destination—the centre of a city, not some airport far outside—the rotor will lower them, straight down, to a safe arrival. A new conception in aircraft design has brought this kind of travel into plain sight—the Rotodyne which is neither aeroplane nor helicopter, but something of both, and the world's first Vertical Take-off Airliner. Note that it conforms to the safety standards internationally recognised for twin-engined fixed-wing aircraft, i.e. it has full single engine performance and safety (Powered by Napier Eland turbo-props).

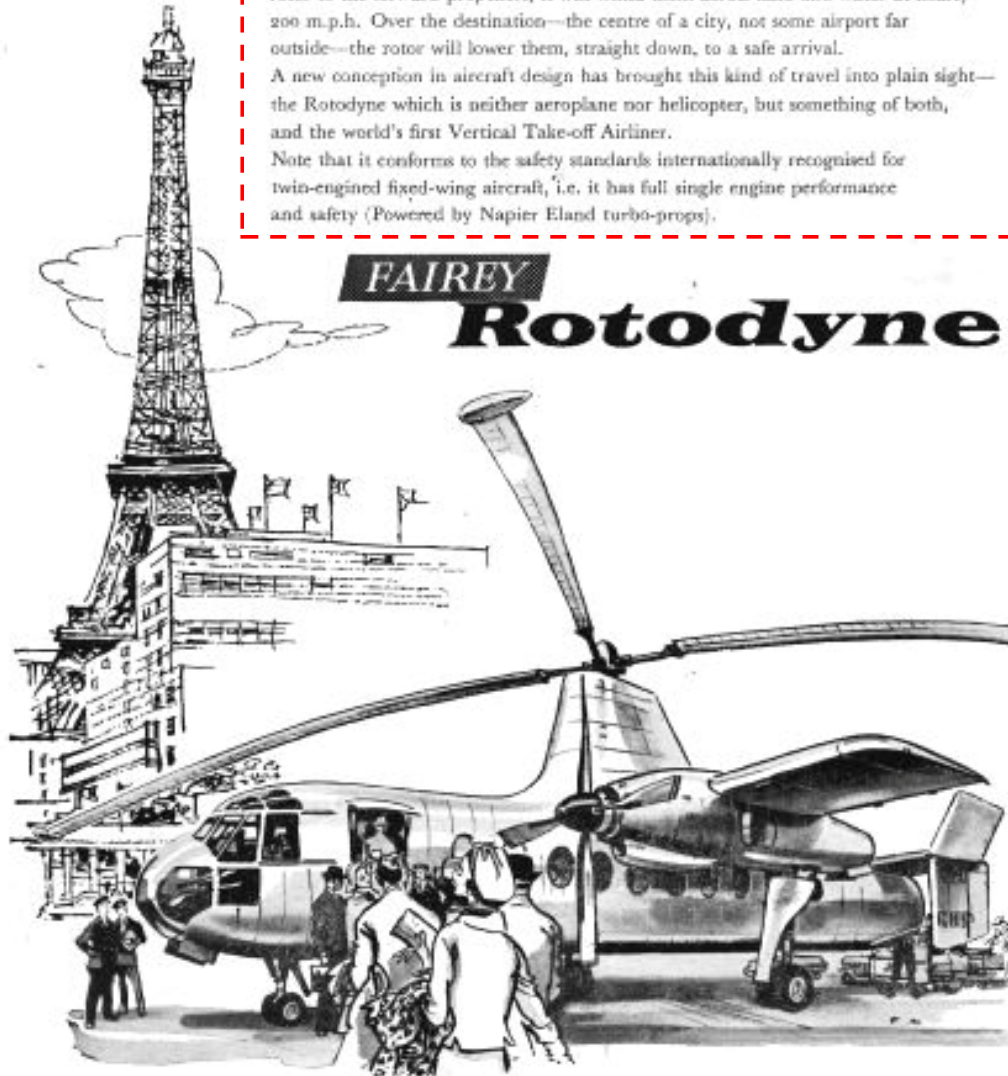

### **FAIREY** **Rotodyne**

**Left:** caption: “This is how people will go from city to city, when we have Rotodyne travel. Forty-eight people will settle themselves in the wide, comfortable cabin of the Fairey Rotodyne, at some small open space in the middle of a town. The Rotodyne will lift them vertically far above chimney-smoke and church spires and then, gradually transferring the power of its two turbine engines from the big rotor to the forward propellers, it will whisk them across land and water at nearly 200 m.p.h. Over the destination the center of a city, not some airport far outside - the rotor will lower them, straight down, to a safe arrival. A new conception in aircraft design has brought this kind of travel into plain sight the Rotodyne which is neither aeroplane nor helicopter, but something of both, and the world's first Vertical Take-off Airliner. Note that it conforms to the safety standards internationally recognized for twin-engined fixed-wing aircraft, i.e. it has full single engine performance and safety (Powered by Napier Eland turbo-props).” (1958 advertisement for the *Fairey Rotodyne*)

***“It is necessary to forgo the operational advances offered by this aircraft, in view of the cost involved...The commercial prospects of the Rotodyne on their routes are not sufficiently assured to justify the heavy liabilities involved...”***

***Minister of Aviation***

**RE: on February 26<sup>th</sup> 1962, the Minister of Aviation announced the cancellation of both the civilian and military versions of the *Rotodyne* project. Absent any firm orders and with excessive cost overruns, *Westland Aircraft Ltd.* (parent of the *Fairey Aviation Division*) felt unjustified in proceeding any further.**

# **The Achievement**



***“...Numerous demonstrations were made in both military and civil roles, and these were used to work up operating flight techniques and to settle operators’ design requirements... Over 800 passengers, including a fair proportion of the world’s airline chiefs, service chiefs, and British MPs, were flown, as a demonstration of the inherent safety of this prototype vehicle of radical design...The Rotodyne Y demonstrated conclusively that a large economic transport VTOL is a practical proposition today – not in 15 years time – and that the unloaded rotor and tip drive made a tremendous breakthrough in performance and handling, in comparison to pure helicopters and other forms of convertiplane...no other VTOL has yet flown to compare with the public demonstrations made year after year where, with up to 35 souls aboard...This is only one of many measures of the achievement of the Rotodyne, and one reason why we could immediately and confidently face a larger and faster design for an operational aircraft...”***

535

***FLIGHT*** magazine, August 9<sup>th</sup> 1962





**Top:** caption: “In the second week of April 1958 the Rotodyne made its first transition to and from the autogyro mode. This is how it appeared on 3 June during a demonstration at White Waltham.”



**Bottom:** caption: “One of the last public appearances of the Rotodyne, in Westland and RAF markings, at the SBAC Show, Farnborough, in September 1961. The project was cancelled five months later.”

# The World's fastest Rotorcraft

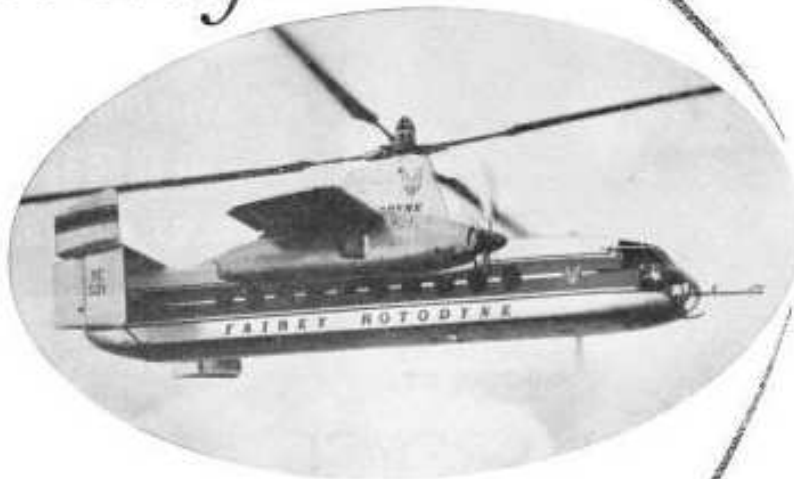

**ROTODYNE sets new world record at 191 m.p.h.**

Fairey's Rotodyne vertical take-off airliner has established itself as the fastest rotorcraft in the world. On 14th January, 1959, it flew round a 62 mile closed-circuit record course at an officially observed average speed of 191 m.p.h. for a new world rotorcraft speed record—at cruising power and operating weight.

This record, almost 30 m.p.h. faster than the corresponding helicopter record and 30 m.p.h. faster than the absolute speed record for helicopters, confirms Fairey's claim that the true V.T.O. airliner is here, now, for city-centre to city-centre journeys, needing no expensive airfields, wasting no valuable time.

(Subject to F.I.A. Confirmation)

**FAIREY**

## Rotodyne

Powered by Napier Eland turbo-prop

THE FAIREY AVIATION COMPANY LIMITED

HAYES · MIDDLESEX  
ENGLAND · AUSTRALIA · CANADA

**“...Early in 1959 it was agreed expedient to establish an official speed record. The 100km closed-circuit was selected as that most representative of the cruiseability of the aircraft, and the Class E.2 Record for Convertiplanes was taken at 307.22km/hr in January 1959. This record stood until October 1961. when the Russian Kamov exceeded it by 28.78 km/hr...”**

**FLIGHT magazine, August 9<sup>th</sup> 1962**  
**Left: advertisement for the Fairey Rotodyne from 1959**



**Above: The *Ka-22 Vintokryl* (“Screw Wing”) was a large twin-turboshaft powered convertiplane that debuted at the *Soviet National Aviation Day* display on July 9<sup>th</sup> 1961 in Tushino. At each end of the high, straight wing, was a 6,500-hp *Soloviev D-25VK* engine which powered a four-bladed rotor for vertical flight and a four-bladed propeller for cruise. Each engine was progressively clutched between the two systems to transition between the two modes of flight. On October 7<sup>th</sup> 1961, the *Vintokryl* set a *Class E. II* speed record of 221.4 mph over a 15/25 km course. On November 24<sup>th</sup> 1961, it lifted a record payload of 36,343 lb to a height of 6,562-feet as well as several other payload-to-altitude records. The *Ka-22* was abandoned after a crash in 1964.**

# **Farewell to Fairey**

The prototype had been built as a 40-seat aircraft with a crew of three. When Westland acquired *Fairey Aviation* in 1960, it abandoned its own large helicopter; the *Westminster*, in favor of the *Rotodyne* and with government backing continued to develop an enlarged version to production standard. This became known as the *Rotodyne Z* (the prototype being restyled *Rotodyne Y*) and as envisaged at the time of its cancellation would have accommodated 57-75 passengers (or 8165 kg of freight) and cruised at 370 km/h on the power of two *Rolls-Royce Tyne* engines. The *Rotodyne Z* had been designed with an eye also on military orders, with a fuselage cross-section capable of admitting standard *British Army* vehicles (a feature which would have made it equally useful as a commercial car ferry). Late in 1960, Westland was invited to quote for building six *Rotodynes* for BEA and twelve troop/vehicle transports for the RAF. When both airline and government declined either to order the aircraft or to contribute further towards its development, Westland finally abandoned the project in February 1962 and the *Rotodyne Z* was never completed.

**FAIREY**



**flies  
the first  
vertical  
take-off  
Airliner**

Adding achievement to achievement, Fairey Aviation have now built—and flown—potentially the most important transport aeroplane in the world, the Fairey Rotodyne. Carrying 48 passengers or 4½ tons of freight it takes off vertically as a helicopter and having gained height flies forward as a normal twin-engined airliner. It is the most adaptable rotary-wing aircraft in the world and the first to offer operating economy directly comparable to that of fixed wing aircraft over ranges of up to 400 miles. The arrangement within the Rotodyne's capacious fuselage can readily be adapted to suit civil or military applications. Powered by two Napier Eland propeller-turbines with Fairey Pressure-Jets at the rotor-tips for take-off and landing.

48 passengers  
185 m.p.h. cruising speed  
400 miles maximum range

**FAIREY**

*Rotodyne*

THE FAIREY AVIATION COMPANY LIMITED - HAYES - MIDDLESEX  
ENGLAND - AUSTRALIA - CANADA

**Left: caption: “Adding achievement to achievement, Fairey Aviation have now built-and flown potentially the most important transport aeroplane in the world, the Fairey Rotodyne. Carrying 48 passengers or 4.5 tons of freight it takes-off vertically as a helicopter and having gained height flies forward as a normal twin-engined airliner. It is the most adaptable rotary-wing aircraft in the world and the first to offer operating economy directly comparable to that of fixed-wing aircraft over ranges of up to 400 miles. The arrangement within the Rotodyne’s capacious fuselage can readily be adapted to suit civil or military applications. Powered by two Napier Eland propeller-turbines with Fairey pressure-jets at the rotor-tips for take-off and landing.” (1958 *Fairey Rotodyne* advertisement)**

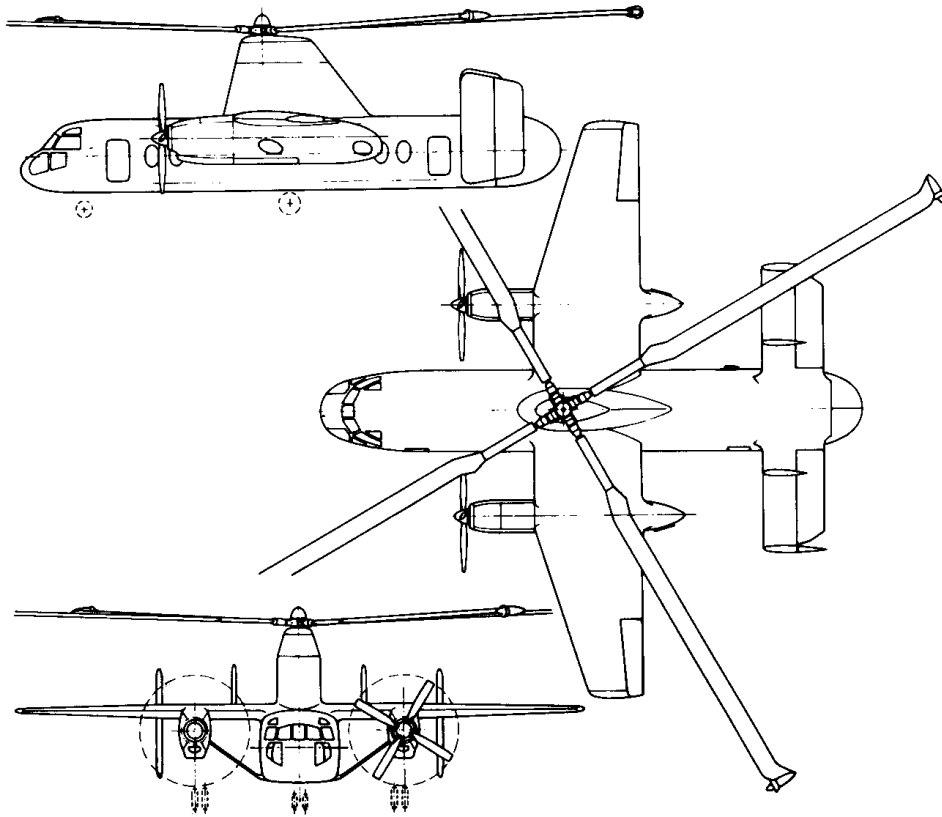

***“...In its last three years of flying, the experimental Rotodyne ‘Y’ obviously suffered from political indecision. This bedevilled all aspects of the project, but, apart from making target dates impossible, programme continuity was kept and all the major test areas - excepting one - had been covered when the contract was cancelled...In all, 302 transitions were made each way, virtually without incident, and the inherent handling safety and simplicity of these maneuvers was considered well proven...”***

***FLIGHT magazine, August 9<sup>th</sup> 1962***

***Top: caption: “Projected production Rotodyne FA-1, Type Z”***

***Bottom: caption: “A model of the proposed Rotodyne 'Z', the production version, in BEA colours”***

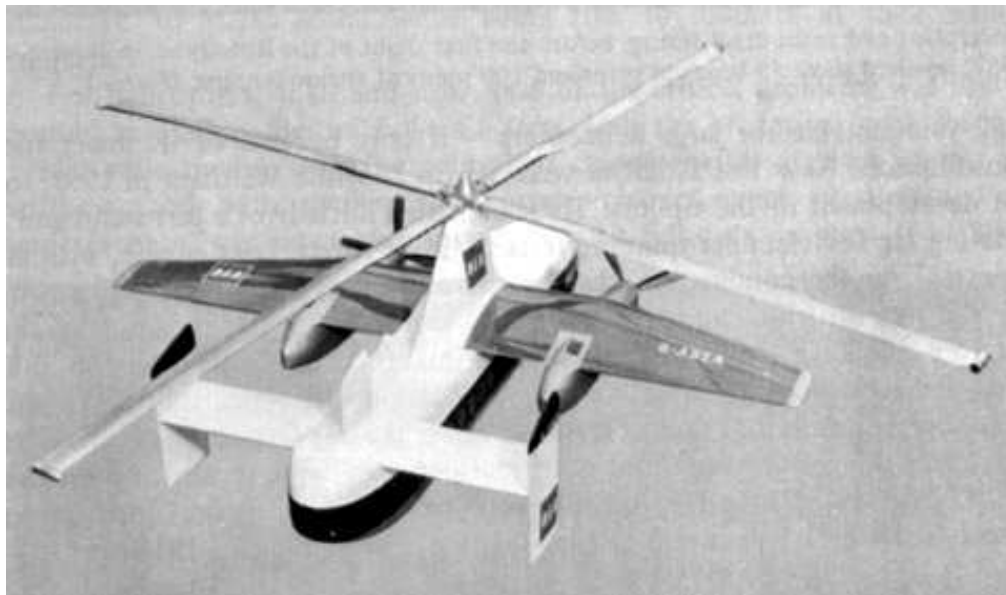

***Okanagan*, the Canadian operator, had tentatively ordered one *Rotodyne* in 1958 and *Indies Air* of *Puerto Rico* signified its interest in the type in 1961. But the major potential customers were BEA and *New York Airways*, which declared their intent to order six and five respectively, each with an option to increase its fleet later to twenty. However, when BEA and the British military refused to place a single order for the aircraft, its fate was sealed.**



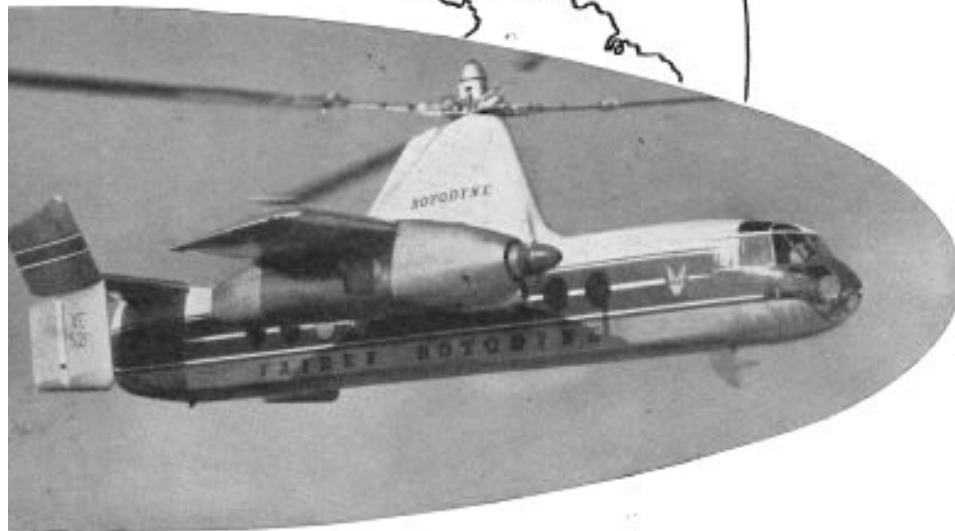

Chosen by the world's largest commercial operator of helicopters, Okanagan Helicopters of Vancouver, the Rotodyne vertical take-off airliner will be in service in two to three years' time. The Rotodyne Era of fast, convenient, comfortable travel is closer than most people have realised. Because of its unique potential, the Rotodyne is regarded as an 'airliner of the future'. And so it is. But the threshold of that future is now just a short step away.

**FAIREY**  
**Rotodyne**

*Powered by Napier Elved turbo-prop.*

**Left: caption: "Chosen by the world's largest commercial operator of helicopters, Okanagan Helicopters of Vancouver, the Rotodyne vertical take-off airliner will be in service in two to three years' time. The Rotodyne Era of fast, convenient, comfortable travel is closer than most people have realized. Because of its unique potential, the Rotodyne is regarded as an 'airliner of the future.' And so it is. But the threshold of that future is now just a short step away." (1958 *Fairey Rotodyne* advertisement)**

**Although lack of faith in the aircraft was the main cause of its demise, a contributory factor was the disproportionate publicity given to the noise made by the Rotodyne's tip-jets, which it was said would inhibit its use in city centers. In fact, well before the aircraft was abandoned, this noise had been successfully decreased to less than that made by a *London Underground* train and there were indications that it could/would have been reduced even further. The Rotodyne put out a painful 106 decibels of shrieking noise. Much work was done on silencers, but it was never reduced to the 96 decibels that the authorities demanded. Budgetary problems of the time saw the British military establishment withdraw their interest and the Rotodyne became a wholly civilian project. Despite Fairey's best efforts to promote the *Rotodyne*, interest from BEA in the UK and *New York Airways* and the military in *America* was never realized thus, the crucial launch order never came. British government policy to "rationalize" the aviation industry saw the end of the Rotodyne and Fairey as an airframe manufacturer in 1962.**



# **A New Age**

**The *Fairey Rotodyne* was a 44-passenger *Gyrodyne*, which used rotorblade “tip jets” to power its rotor giving it *VTOL* (Vertical Take-Off and Landing) capabilities and, critically, allowed it to hover like a helicopter – something the Autogiro could not do. This 200 mph VTOL airliner was, in its day, the fastest way to get from downtown *London* to downtown *Paris*. If it existed today, even without modern improvements, it would still be the fastest, safest method of travel between those two city centers. While British development of the *Gyrodyne* was discontinued in a 1960s recession, in the U.S. it took a significant step forward four decades later when, in November 2005, the *Defense Advanced Research Projects Agency* (DARPA) awarded a \$40 million four phase contract to a *Groen Brothers Aviation* (GBA) led team to design a proof-of-concept high speed, long range, VTOL aircraft for use in *Combat Search and Rescue* (CSAR) roles.**

# Heliplane



***“If this program is successful, it will change the nature of VTOL, it could be the birth of a new age of rotary-wing aviation.”***

**DARPA**

**Above: caption: “Named the “Heliplane” by DARPA, it will be the first rotary-wing aircraft with performance comparable to a fixed-wing in speed and efficiency and will exploit Gyrodyne technology. It will be able to take-off and land vertically, reach a top speed of 400 mph and carry a 1K-lb. payload over a 1K-mile range without refueling.”**

# GyroLiner





***“The rapid growth of economic and environmental costs of airport and airspace congestion demands a revolution in civil aviation that a modern gyroplane can achieve. The replacement of conventional regional airplanes by safe, quiet runway independent commuter GyroLiners would free up valuable runway and airway space. It can significantly increase airport capacity at little or no infrastructure investment cost or environmental hazard. This could dramatically ease the current predicament of many airports worldwide that are overcrowded and landlocked. GBA GyroLiners could also make smaller local airports viable and make possible ‘downtown to downtown’ flights into new Vertiports established in city centers, permitting air travel to be more convenient and cost-effective than it has ever been.”***

552

***Groen Brothers Aviation***

# GyroLifter



***“GBA gyrodynes could also serve effectively in a wildfire suppression role. Experience in the growing occurrences of the fast moving fires in the U.S. west, in Europe, and in Australia has underscored the importance of a timely ‘initial attack’ to preclude heavy losses of life and property. Because of its versatility and heavy load carrying capacity, the GBA Monsoon GyroLifter would give firefighters the ‘on-site’ quick turnaround capabilities and low speed water/retardant drop accuracy of a helicopter; and the reliability, load carrying capacity, high speed deployment, and low operating cost of a fixed-wing fire bomber.”***  
*Groen Brothers Aviation*

# **Military Applications**



***“Military applications include various options for fast VTOL ‘Combat Search and Rescue (CSAR)’ aircraft as envisaged by DARPA. However, gyrodyne technology enables much larger aircraft that take advantage not only of the scalability of the gyrodyne concept, but also its disproportionate gains in payload efficiency with size compared to conventional rotorcraft. To meet the U.S. Army’s need for a fast VTOL heavy lift transport, the GBA GyroLifter would be able to carry large loads of troops and equipment long distances without the need for runways. This aircraft would be far superior in speed, range, economy, reliability, mission readiness, and cargo/troop hauling capacity, compared to any other VTOL aircraft now available. Other military variants of this gyrodyne technology include critical multi-role aircraft necessary for an effective sea-based strategy, and VTOL Unmanned Aerial Vehicles.”***

# Special Applications



***“Small gyrodynes with the ability to hover could also serve a variety of roles that are currently served by conventional helicopters and do so at faster speeds, larger payloads and greater economy, such as corporate travel, oil rig servicing, and medical evacuation. The introduction of the GBA GyroLifter heavy lift gyrodyne to military service would permit the subsequent emergence of commercial VTOL freighters able to deliver heavy loads to areas lacking runways capable of handling conventional airplanes.”***

***Groen Brothers Aviation***

# **Part 7**

## **An On-Going Legacy**



# All But Extinct



## The Passing of the GYROPLANE

by W. GREEN

**DATA**  
 One 330-h.p. Bearn 6D six-cylinder in-line air-cooled motor.  
 Performance: Max. speed, 137 m.p.h.; range, 280 miles; climb, 834 ft./min.  
 Dimensions: Rotor diameter, 43 ft. 6½ in.; fuselage length, 20 ft. 7½ in.; overall height, 12 ft. 2 in.  
 Accommodation: Three persons and 220 lb. baggage or two persons and 441 lb. of freight.

Since the death of Senor Juan de la Cierva in 1936 the gyroplane has gradually lost ground to the helicopter, and its species is now all but extinct. It is doubtful if the true gyroplane will again be produced, but representative of a rare intermediate stage between gyroplane and helicopter is the French SE-700, some interesting photographs of which are presented here.

The SE-700, which was built in small numbers at Marignanne for the French Postal Services, has a large power-driven three-bladed rotor which provides vertical-lift take-off and landing, and a tractor airscrew in the nose for forward flight. Power is provided by a 330-h.p. Bearn 6D air-cooled motor, which is placed in the rear section of the fuselage with an extension shaft to the tractor airscrew. An unusual feature of the design is that twin rudders are hinged

to the rear-wheel fairings. A semi-enclosed retractable nose wheel is mounted beneath the fuselage.



Left: caption: "Since the death of Senor Juan de la Cierva in 1936 the gyroplane has gradually lost ground to the helicopter, and its species is now all but extinct. It is doubtful if the true gyroplane will again be produced, but representative of a rare intermediate stage between gyroplane and helicopter is the French SE-700...The SE-700, which was built in small numbers at Marignanne for the French Postal Services, has a large power-driven three-bladed rotor which provides vertical-lift take-off and landing, and a tractor airscrew in the nose for forward flight. Power is provided by a 330-h.p. Bearn 6D air-cooled motor, which is placed in the rear section of the fuselage with an extension shaft to the tractor air-screw. An unusual feature of the design is that twin rudders are hinged to the rear-wheel fairings. A semi-enclosed retractable nose wheel is mounted beneath the fuselage."

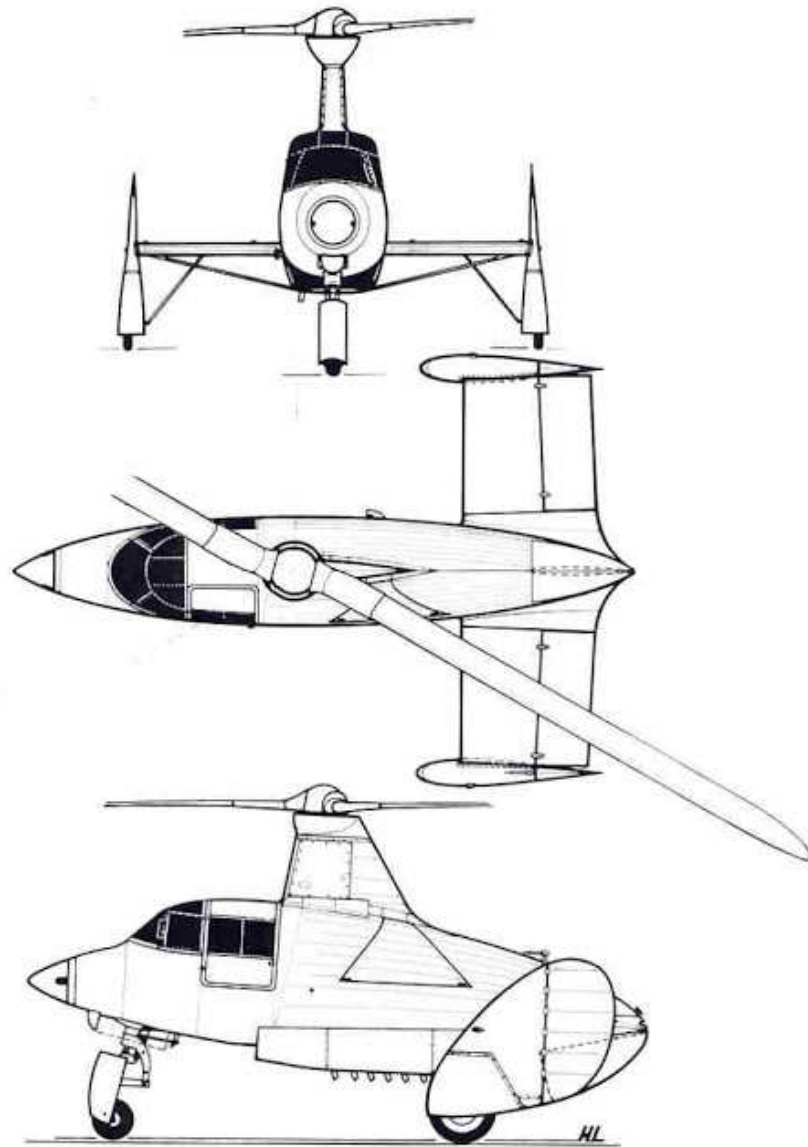

Design of the *SE-700 Gyroplane* (left) was begun by the *Societe Nationale de Constructions Aeronautiques du Sud-Est* (SNCASE) immediately after the German occupation in June 1940. Of wooden construction, the fuselage was of extremely aerodynamic shape with a minimum of protrusions. It was the first rotorcraft with a retractable landing gear with the nose wheel retracting into the fuselage while the main wheels were almost entirely obscured by the tall and slender fairings (which also served as additional fins). The cabin seated a pilot and two passengers. Power was provided by a 220-hp *Renault 6Q-01* engine. Construction began in the summer of 1944 and on May 25<sup>th</sup> 1945, test pilot *Henri Stakenburg* flew the aircraft for the first time at *Marignanne*. The aircraft performed well and showed great promise. However, the Gyroplane was badly damaged in an unsuccessful landing on January 6<sup>th</sup> 1946 and it was decided not to rebuild it. Rather, the focus would be on fine-tuning the improved *SE-700A*, but due to the unavailability of the *Bearn 6D-07* engine, this second prototype never flew and the 562 *SE-700* program was ended.

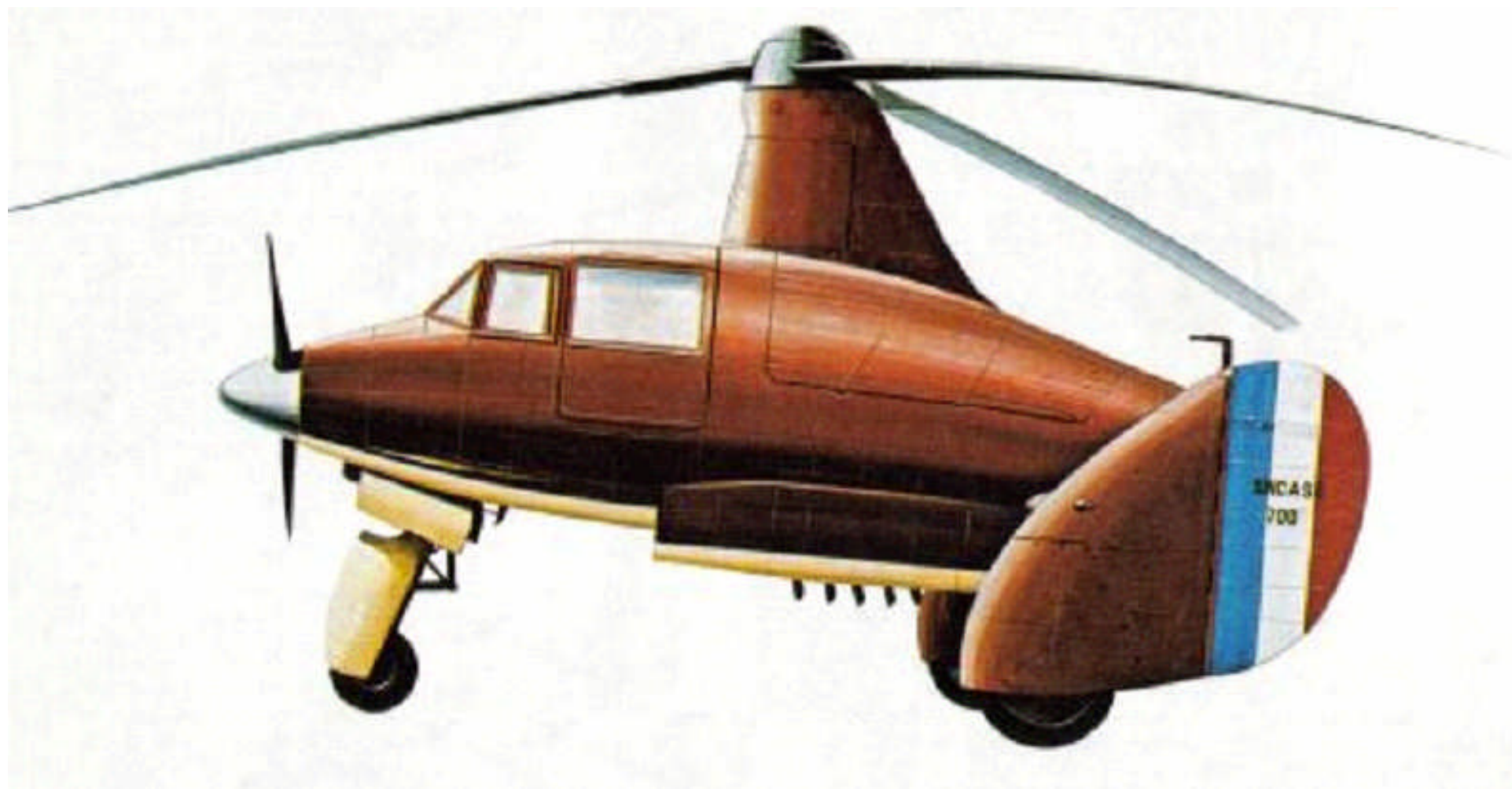



The Autogiro was resurrected after WW II when *Dr. Igor Bensen*, a Russian immigrant to the *United States*, saw a captured German U-Boat's *Fa 230 gyro glider* (top left – a.k.a. *rotor kite*) and was fascinated by its characteristics. At work he was tasked with the analysis of the British military *Rotachute* gyro glider (top right) designed by expatriate Austrian *Raoul Hafner*. This led him to adapt the design for his own purposes and eventually market the *B-7*. Bensen submitted an improved version, the *Bensen B-8M* (left) for testing to the *U.S. Air Force*, which designated it the *X-25*. The *B-8M* was designed to use surplus *McCulloch* engines used on flying un-<sup>564</sup>manned target drones.

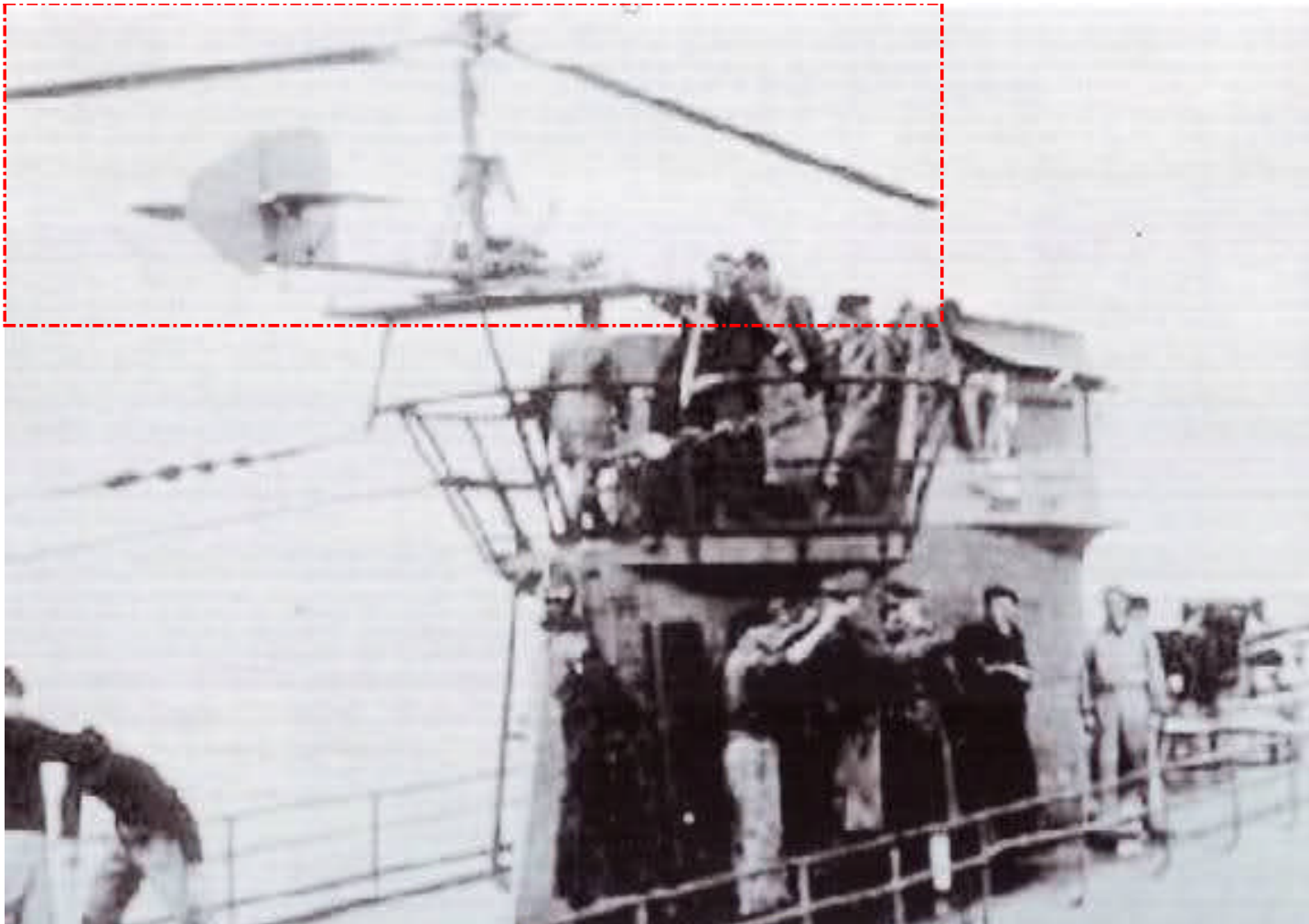

When surfaced, a *U-Boat* had a low profile on the horizon which limited their visibility and, therefore, ability to locate target ships. To give the U-Boat greater range of vision, in 1942 *Focke Achgelis* began manufacturing a *Rotor Kite* – the *FA 230 Bachsteize* (a.k.a. “Wagtail”). When deployed (above), it could rise high above the U-Boat and, with an observer using powerful *Zeiss* binoculars, could spot the smokestacks of enemy ships. It was then recovered and the U-Boat headed towards its prey.





***“New Model two-seat Gyro-Glider has no engine. It soars when towed by a car or motorboat and is controlled in the air by an overhead stick, like a full-size helicopter. The craft weighs 98 pounds and totes a 500-pound pay load. It takes off at 25 mph and cruises at 35 mph. In a strong wind it can be flown like a kite on a long rope tied to the ground. Kit (\$100) and plans (\$10) are available from Bensen Aircraft Corp., P. O. Box 2746, Raleigh, N. C. Solo in three hours!”***

***Mechanix Illustrated, Nov. 1959***





FLYING is much like plane flight: conventional prop combines with auto-rotation.

## REBIRTH OF THE AUTOGIRO

FARMERS who want a crop duster with low, slow, safe flight capability and short takeoff and landing needs can have it for slightly over half the price of a helicopter of comparable size. Kellett Aircraft Corp., Willow Grove, Pa., has dusted off its 25-year-old autogiro and is offering it for \$27,500 to an age that knows the value of rotary-wing aircraft. Free-wheeling rotors have no fancy, costly gearbox. Plane pilots need little instruction on it. \*



FOLDING ROTORS are handy in flight, too—they blow dust down, spare the pilot's lungs.



**“Farmers who want a crop duster with low, slow, safe flight capability and short takeoff and landing needs can have it for slightly over half the price of a helicopter of comparable size. Kellett Aircraft Corp., Willow Grove, Pa, has dusted off its 25-year-old autogiro and is offering it for \$27,500 to an age that knows the value of rotary-wing aircraft. Free-wheeling rotors have no fancy, costly gearbox. Plane pilots need little instruction on it.”**

RE: excerpt from a 1959 magazine article (left)

# **Birth of the Gyrocopter**

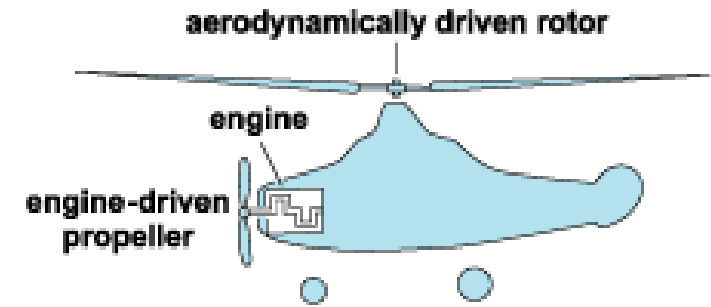

**Above: Bensen Aircraft B8MG Gyrocopter. Modern Autogiros typically follow one of two basic configurations. The most common design is the pusher configuration, where the engine and propeller are located behind the pilot and rotor mast, such as in the Bensen “Gyrocopter” developed by Igor Bensen in the post-WWII era. Less common today is the tractor configuration. In this version, the engine and propeller are located at the front of the aircraft, ahead of the pilot and rotor mast (right). This was the primary configuration in early Autogiros, but became less common after the advent of the helicopter. It has enjoyed a revival since the mid-1970s.**



The basic *Bensen Gyrocopter* design is a simple frame of square aluminum or galvanized steel tubing reinforced with triangles of lighter tubing. It's arranged so that the stress falls on the tubes, or special fittings, not the bolts. A front-to-back keel mounts a steerable nose-wheel, seat, engine and a vertical stabilizer. Outlying main-wheels are mounted on an axle. Some versions mount seaplane-style floats for water operations. The rotor is mounted atop the vertical mast. The rotor system of all Bensen-type Gyrocopters is of a two-blade teetering design. There are some disadvantages associated with this rotor design, but the simplicity of the configuration lends itself to ease of assembly and maintenance and is one of the reasons for its popularity. Aircraft-quality birch was specified in early Bensen designs and a wood/steel composite is used in the world speed record holding *Wallis* design. Gyrocopter rotor blades are made from other materials such as aluminum and GRP-based composite blades.



Left T&B: VPM M-16 Gyrocopter







**Bensen-type Gyrocopters use a pusher configuration for simplicity and to increase visibility for the pilot. Power can be supplied by a variety of engines; *McCulloch* drone engines, *Rotax* marine engines, *Subaru* automobile engines and other power-plants have been used in Bensen-type designs. Because of Bensen's pioneering of the concept and the popularity of his design, “Gyrocopter” has become a generic trademark for pusher configuration Gyroplanes.**

**Above: VPM M-16 Gyrocopter**

**Left: the rotor head, pre-rotator shaft and Subaru engine configuration on a VPM M-16 Gyrocopter**

**Shaken, Not Stirred**





**Ken Wallis** (seated above), a former RAF pilot, developed a number of improvements to the Gyrocopter including the offset gimbal rotor head which gives the craft hands-off stability. Wallis' first prototype was first flown on August 2<sup>nd</sup> 1961. The *Wallis WA-116 Agile* was produced in a number of variants, one of which was nicknamed *Little Nellie* (above) appeared in the *James Bond* film *You Only Live Twice*. 576

**SEAN  
CONNERY  
IS  
JAMES  
BOND**

IAN FLEMING'S  
**"YOU  
ONLY  
LIVE TWICE"**



*...and "TWICE" is the only way to live!*

Produced by HARRY SALTZMAN ... ALBERT R. BROCCOLI    Screenplay by LEWIS GILBERT    Story by ROALD DAHL  
Directed by HARRY SALTZMAN ... ALBERT R. BROCCOLI    Based on the novel by JOHN HARRY    Music by KEN ADAM    PANAVISION  
Technicolor    United Artists

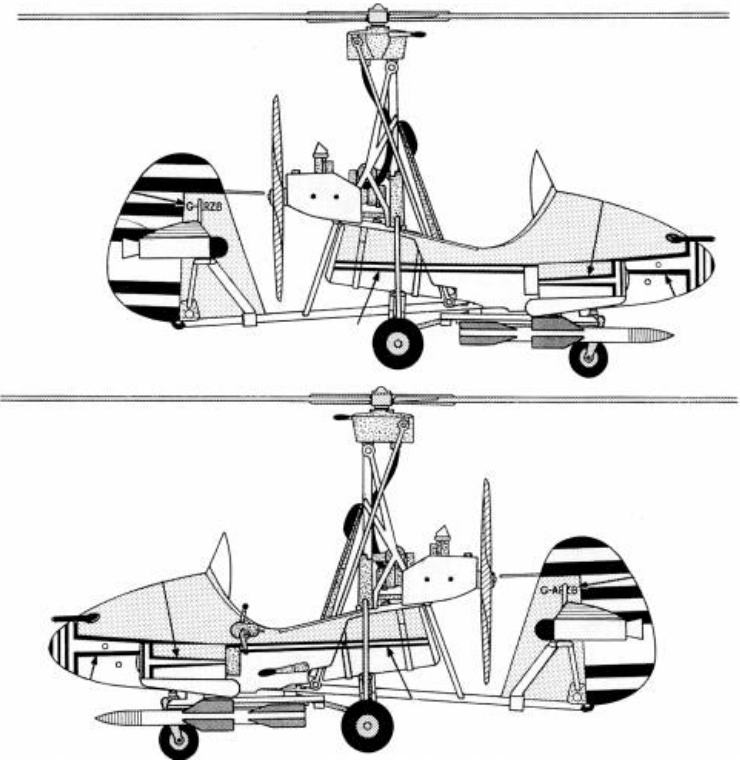





FLOWN LOCALLY ON TRAINING FLIGHT FROM ROYAL AIR FORCE NORTHOLT ABOARD GAZELLE HT MK 3 HELICOPTER XZ 935 OF No. 32 SQUADRON.

PILOT: FLIGHT LIEUTENANT B. A. ROWLANDS, RAF  
 NAVIGATOR: SQUADRON LEADER R. M. KERR, RAF  
 FLIGHT TIME: 1 HOUR 15 MINUTES

*Wallis*  
**AUTOGYRO**

Officer  
 Commanding  
 Royal Air Force  
 Chivenor, Devon



**Above: Wing Commander Wallis and the *Wallis WA-116-T* Autogiro <sup>581</sup>**

# WORLD RECORDS FOR AUTOGYRO AIRCRAFT HELD BY WING COMMANDER KENNETH H. WALLIS CONFIRMED BY THE FEDERATION AERONAUTIQUE INTERNATIONALE



DATE	PLACE	AIRCRAFT	ENGINE	RECORD	CLASS	PERFORMANCE
11 May 1968 <b>20 JULY 1982</b>	Boscombe Down, Wiltshire	Wallis WA-116/Mc, G-ARBT	Wallis/McCulloch 1634 cc, 72 hp.	Altitude	E-3 E-3a	4639 Metres (15220 feet) <b>574.3m 18540'</b>
12 May 1969 <b>18 SEPT 1986</b>	Boscombe Down, Wiltshire <b>RAF MARHAM</b>	Wallis WA-116/Mc, G-ARBT	Wallis/McCulloch 1634 cc, 72 hp.	Speed over 3 kms.	E-3 E-3a	179 kms/hr. <b>193.6</b>
13 July 1974 <b>5 AUG 1988</b>	Norfolk (RAF Coltishall - RAF W Raynham - Hardingham)	Wallis WA-116/F, G-ATHM <b>WA-116/F/S G-BLIK</b>	Franklin 2A-120, 1960 cc, 60 hp.	Non-Stop distance in 100 km. Closed circuit	E-3	<b>1000.75 Km</b>
13 July 1974 <b>5 AUG 1988</b>	Norfolk (RAF Coltishall - RAF W Raynham - Hardingham)	Wallis WA-116/F, G-ATHM <b>WA-116/F/S G-BLIK</b>	Franklin 2A-120, 1960 cc, 60 hp.	Speed in 500 km. Closed circuit	E-3	126-14 kms/hr. <b>130.78</b>
13 July 1974 <b>17 APRIL 1985</b>	Norfolk (RAF Coltishall - RAF W Raynham - Hardingham)	Wallis WA-116/F, G-ATHM <b>WA-116/F/S G-BLIK</b>	Franklin 2A-120, 1960 cc, 60 hp.	Speed in 100 km. Closed circuit.	E-3	130.67 kms/hr. <b>190.4 kms/hr</b>
28 Sept. 1975	England & Scotland (Lydd to Wick)	Wallis WA-116/F, G-ATHM	Franklin 2A-120, 1960 cc, 60 hp.	Non-Stop distance in a straight line	E-3	874.315 kms.
28 Sept. 1975	England & Scotland (Lydd to Wick)	Wallis WA-116/F, G-ATHM	Franklin 2A-120, 1960 cc, 60 hp.	Duration	E-3	6 hours 25 minutes
17 July 1978 <b>14 Oct 1984</b>	Cambridgeshire (Mepal-Weiney) <b>CHATTERIS - UPWELL</b>	Wallis WA-116/F, G-ATHM <b>G-BLIK</b>	Franklin 2A-120, 1960 cc, 60 hp.	Speed over 15 kms	E-3	168 kms/hr. <b>189 kms/hr</b>

\* Subject to confirmation by F.A.I.  
NOTE: Class E-3 is for autogyros of any weight, i.e. the "Unlimited" Class  
E-3a is for autogyros under 500 kgs., all-up weight.

## ALL WORLD RECORDS ACHIEVED USING BP AVIATION FUELS

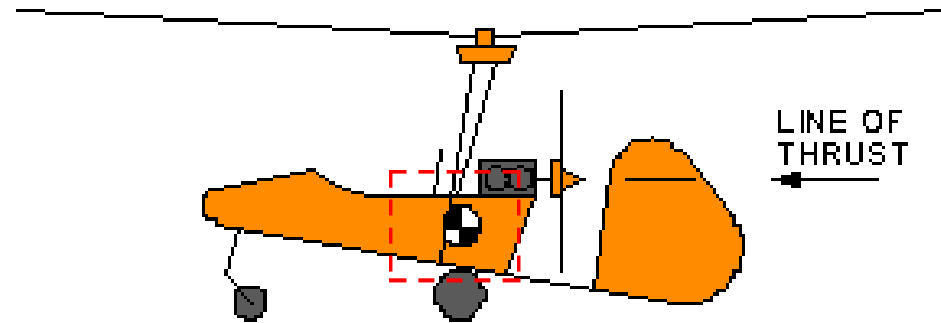

The success of *Igor Bensen* triggered a number of other designs, some of them fatally flawed with an offset between the *Center of Gravity* (CG) and thrust line, risking a *Power Push-Over* (PPO or “bunt-over”) causing death or serious injury to the pilot and giving Gyrocopters, in general, a bad reputation. A power pushover is a situation where the rotor is, in effect, uncoupled from the aircraft. This will only happen if the CG lies below the *Line of Thrust* (in the figure above, the CG is denoted by the circle-with-blocks symbol). Designers must take great care to make sure the CG of the aircraft as a whole remains above the Line of Thrust under all loading conditions.





Three different Gyrocopter designs have been certified by the *Federal Aviation Administration* for commercial production:

- *Umbaugh U-18/Air & Space 18A* of 1965 (top Left);
- *Avian 2-180 Gyroplane* of 1967 (top right), and;
- *McCulloch J-2* of 1972 (left)

All have been commercial failures for various reasons



Over 1K Autocopters worldwide are used by authorities for military and law enforcement. The first U.S. police authority to evaluate one was the *Tomball, Texas* police dept. with a \$40K grant from the *Department of Justice* together with municipal funds. At \$75K, it cost much less than a helicopter to purchase and, at \$50/hour, is much more economical to operate and maintain. Since 2009, several projects in *Kurdistan, Iraq* have been realized. In 2010 the first Autocopter was handed over to the Kurdish Interior Minister. These Gyrocopter pilots (above) form the backbone of the pilot crews of the Kurdish police who are trained <sup>585</sup> to pilot on *Eurocopter EC 120 B* helicopters (in hangar).



**Above: the *ELA 07* is a series of Spanish Gyrocopters, designed and produced by *ELA Aviacion* of *Cordoba, Andalusia*. The aircraft are supplied complete and ready-to-fly. The *ELA 07* series features a single main rotor, a two-seats-in-tandem open cockpit with a windshield, tricycle landing gear with wheel pants and a four cylinder, air-cooled, four-stroke, dual-ignition 100-hp *Rotax 912S* engine in pusher configuration. The turbocharged 115-hp *Rotax 914* power-plant is optional.**



**Above & Left: *Montgomery Merlin GTS Gyrocopter.* This single seat Autogiro has an excellent safety record and is the latest development of this type of Aircraft, based on a proven “Kit-Built” Airframe. It was designed, built and tested by *Jim Montgomery* and is the result of over twenty years of continuous research and development.**



# **GBA Hawk Series**



***“Designed to emerge as the world’s most practical and cost-effective runway independent aircraft, GBA’s ArrowHawk can be significantly more profitable for commercial applications and can provide significant savings for law enforcement and government agencies as well. Needing no runway, the GBA ArrowHawk leaps into the air like a helicopter, lands vertically, and yet flies at the higher speeds offered by fixed-wing airplanes. It carries up to seven people and does all of this at a fraction of the operational cost of a typical helicopter. Best of all, a properly designed gyroplane is the safest form of powered flight.”***

***Groen Brothers Aviation***



***“GBA’s field tested Hawk 4 Gyroplane flew dozens of security missions for the 2002 Winter Olympic Games in Salt Lake City. Its extremely high operational readiness, reliability, and low maintenance demonstrated the superiority of the gyroplane – perfect for the job at hand. GBA’s next generation of high performance gyroplanes, such as the new two-place ShadowHawk, are capable of doing an even better job, offering greater cost effectiveness in airborne observation for police and for utility infrastructure inspection, such as pipeline and power lines, where safe, close to the ground, and slow speed flight is essential.”***

***Groen Brothers Aviation***



*GBA Hawk 4 Gyroplane  
Homeland Defender™*



*GBA Hawk 4 Gyroplane - Homeland Defender™*  
GROEN BROTHERS AVIATION HAWK 4 GYROPLANE USED BY  
THE UTAH OLYMPIC PUBLIC SAFETY COMMAND (UOPSC)  
AS AN AERIAL OBSERVATION AIRCRAFT

Performance - Engine - 420 shp Rolls-Royce Model 250 series gas turbine	Observation Loiter Speed 40-70 knots
Cruise Speed 115 knots	Routine U-STOL Capability
Endurance On Station 3.5 Hours	Rapid Response
Unparalleled Safety	Easy Pilot Transition
Highly Maneuverable	
Higher Utilization Availability due to Minimum Maintenance Requirements	

Installed Equipment  
Bendix-King- Communications pkg including GPS/COMM and Transponder.  
National Airborne Technologies- Law enforcement Communications package  
with audio panel and UHF interface.

Spectrolab- SX-5 search Light  
FLIR Systems - Dual Imaging Camera and Monitor  
AVALEX- Flat panel video display  
Broadcast Microwave Systems- Video downlink  
Whelen- Exterior Lighting System

*Delivery within  
10 months of receipt of  
order accompanied  
by deposit.*

Groen Brothers Aviation, Inc. (801) 973-0177 Fax (801) 973-4027  
www.gbagyros.com Stock Symbol: GNBA

Headed by brothers *David and Jay Groen*, *Groen Brothers Aviation* developed a family of larger *Hawk 4 Gyroplanes* targeted to the agricultural, law enforcement, military, package delivery and passenger shuttle service markets. In its November 19<sup>th</sup> 2001 issue, *TIME* magazine named the Hawk 4 as one of the best inventions of the year.



The *Utah Olympic Public Safety Command (UOPSC)* made use of a *Hawk 4* (left) during the 2002 Olympics with a *FLIR Systems* day/night observation system, a *Spectrolab SX-5* search light, an *Avalex Technologies* flat panel display, a *Broadcast Microwave Services* real-time video down-link system and a law enforcement communications radio stack. GBA succeeded in defining a reconnaissance mission for the Gyroplane where others have failed.



***“The SparrowHawk is an enclosed, centerline thrust, two-place kit-built gyroplane. It is a dynamically and statically stable aircraft that provides a high degree of safety for the recreational pilot. The large two-place cabin with a width of 44 inches provides great visibility and comfort for the pilot and passenger.”***

***Groen Brothers Aviation***

# State-of-the-Art

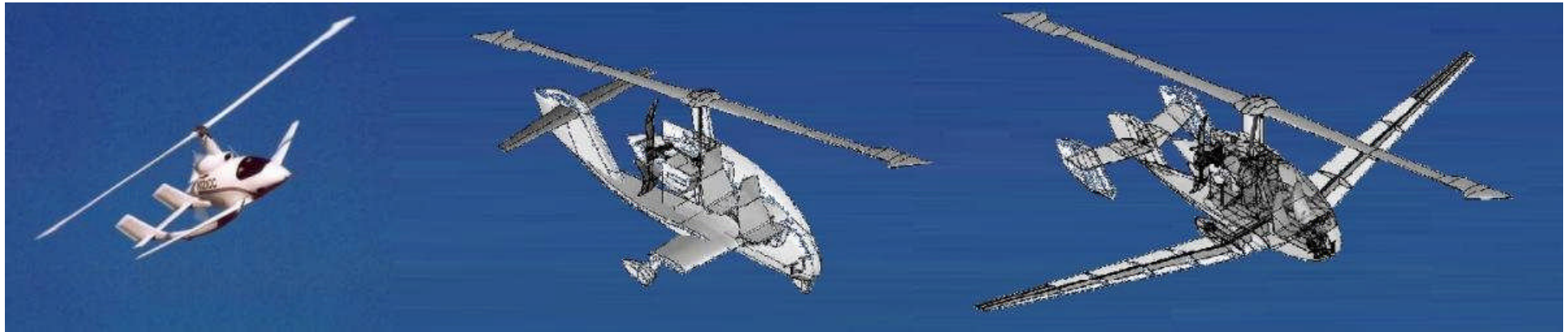

***“Carter Aviation Technologies, LLC is an aerospace research and development firm that has developed and demonstrated new and improved aviation concepts, including its Slowed-Rotor/Compound (‘SR/C’) Technology. SR/C Technology couples the speed, range and efficiency of an airplane with the vertical takeoff and landing (VTOL) capability of a helicopter and is scalable in size from very small unmanned aerial vehicles (UAVs) to large transport aircraft the size of a Boeing 767 equivalent. Whether incorporated into a non-powered rotor (transient hover capable) or a powered rotor (continuous / sustained hover capable) configuration, SR/C Technology offers the same extraordinary benefits during cruise flight in terms of dramatically enhanced speed and range performance.”***

***[www.cartercopters.com](http://www.cartercopters.com)***

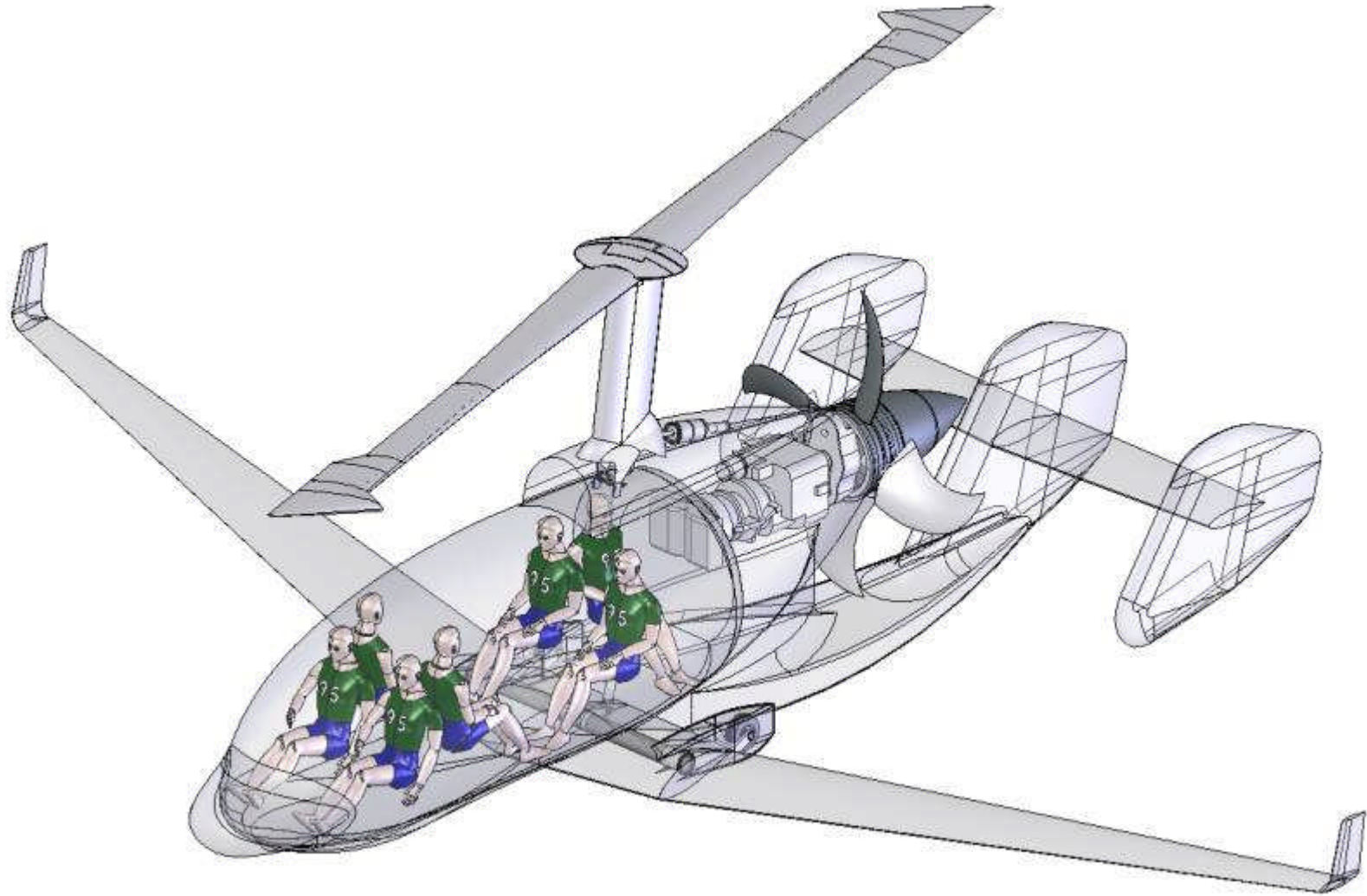



**Above & Left: caption: “CarterCopter CCTD in flight. Developed by Jay Carter, Jr. and associates, the state-of-the-art Carter Copter Technology Demon-strator is the most innovative rotary aircraft flying today and is advancing Juan de la Cierva’s autogyro technology to the next level.”**

Man's Challenge to Nature ...

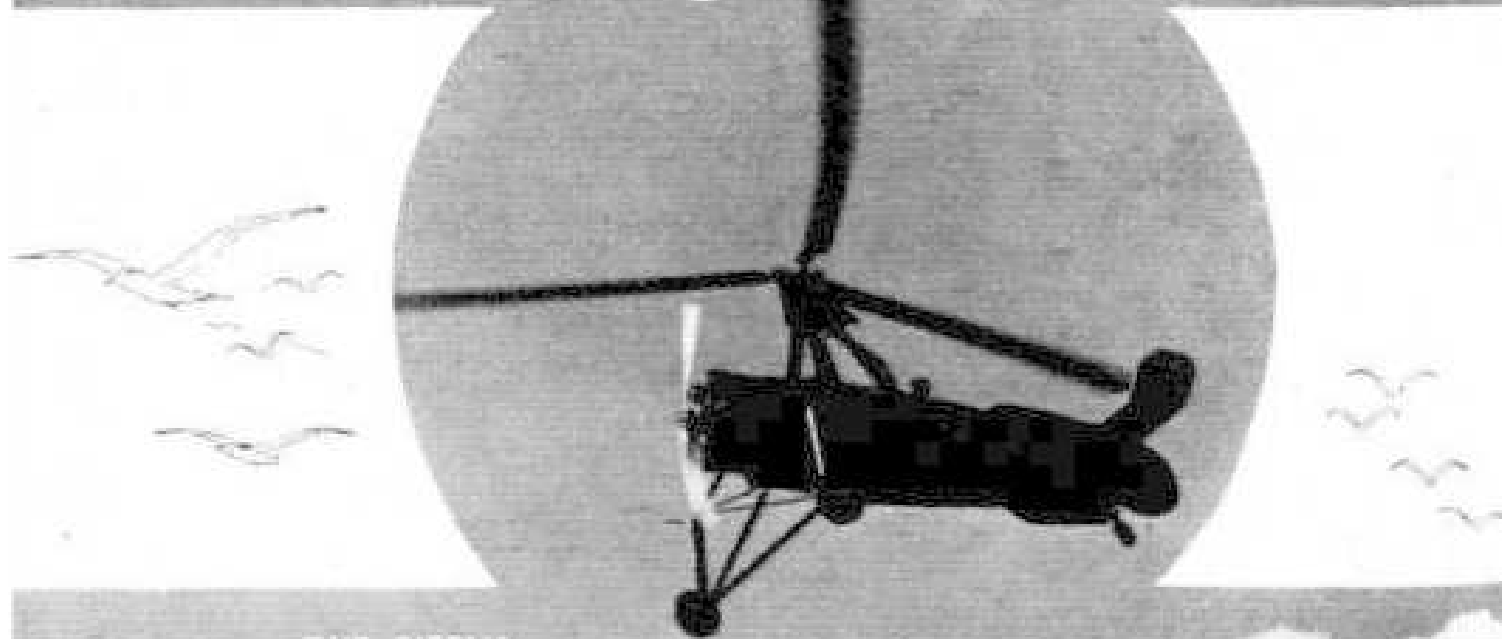

THE CIERVA

**AUTOGIRO**

The CIERVA AUTOGIRO CO. LTD. BUSH HOUSE ALDWYCH LONDON W.C.2.

TELEPHONE: TRAFALGAR 2541



