



PDHonline Course M513 (2 PDH)

An Introduction to Power Plant Load Shedding and Cogeneration

Instructor: J. Paul Guyer, P.E., R.A., Fellow ASCE, Fellow AEI

2020

PDH Online | PDH Center

5272 Meadow Estates Drive
Fairfax, VA 22030-6658
Phone: 703-988-0088
www.PDHonline.com

An Approved Continuing Education Provider

An Introduction to Power Plant Load Shedding and Cogeneration

J. Paul Guyer, P.E., R.A.

CONTENTS

- 1. LOAD SHEDDING**
- 2. POWER PLANT COGENERATION**

(This publication is adapted from the *Unified Facilities Criteria* of the United States government which are in the public domain, have been authorized for unlimited distribution, and are not copyrighted.)

(Figures, tables and equations in this publication may at times be a little difficult to read, but they are the best available. **DO NOT PURCHASE THIS PUBLICATION IF THIS LIMITATION IS UNACCEPTABLE TO YOU.**)

1. LOAD SHEDDING

1.1 OBJECTIVES OF LOAD SHEDDING PROGRAM. When a power plant or an individual power generating unit experiences a gradual increase in load, or a sudden but mild overload, the unit governors will sense the resulting speed change and increase the power input to the generator. The additional load is handled by using the spinning reserve; that is, the unused capacity of the generator. However, if all generators are operating at maximum capacity, the spinning reserve is zero and the governors may not be able to relieve the overload. When severe overloads occur, or when large sudden load increases are experienced, the first effect is a slowing down of the generator. If the overload is large enough or if the governor cannot accommodate the sudden load increase, then speed and frequency will continue to drop until the plant or generating unit is tripped to prevent equipment damage, and the load is lost.

1.1.1 DEFINITION. Load shedding is the deliberate and selective dropping of electrical load in accordance with a preplanned program.

1.1.2 PURPOSE. The purpose of load shedding is to reduce plant loads so that the plant will not trip on overload and so that certain preselected loads can be saved, even though other loads are lost.

1.2 REQUIREMENTS FOR LOAD REDUCTION. A typical scenario in which load shedding would be advantageous would be the case of a power plant operating in parallel with a utility, with a total system load exceeding the capability of the plant alone. Should the interconnection trip, the plant would experience a sudden overload

from which it might not be able to recover. Another scenario could involve an isolated plant (not interconnected with a utility), with several generating units loaded at or near their combined capability. Should one unit trip, the remaining units would experience a sudden load increase, possibly leading to loss of the plant.

1.2.1 STABLE OPERATION AND OVERLOAD CAPABILITY. Generating plants are highly sensitive to frequency drop. There are two major problem areas.

1.2.1.1 MOTOR SPEED. Motor-driven auxiliaries, particularly boiler feedwater pumps, will slow down, reducing generator output. Safety margins in generator-cooling and bearing lubricating systems will be reduced. The lowest safe plant operating speed will depend on the safety margins included in the plant design. However, operation below the 56.6 to 57.5 Hz range is generally not advisable.

1.2.1.2 TURBINE BLADE FATIGUE. The last rows of long, low-pressure blades in steam turbines are tuned to operate free of resonance in a narrow band of frequencies around 60 Hz. When running under heavy load at about 58.5 Hz or below, the steam excitation frequency approaches blade resonance. Under this condition, the blades may vibrate severely, producing fatigue stress. On the average, blades should not be subjected to more than ten minutes of severe vibration totaled over their lifespan; fatigue is cumulative. Operation below about 58.0 to 58.5 Hz should be avoided; the generator protective devices may trip the unit in this speed range, regardless of load. Frequency and time limits for turbines should be specified by the turbine manufacturer, and protective system operation by the plant designer.

1.2.2 GENERATING UNIT SIZES. In order to design an effective load shedding scheme, the following information is required for each generating unit in the plant.

- a) The lowest safe operating speed (F) in Hz.
- b) The rated capacity (MW) of the machine in megawatts.
- c) The power factor (p) rating of the machine, dimensionless.
- d) The inertial constant (H) of the machine in megawatt seconds per MVA.

1.2.3 NUMBER OF GENERATING UNITS. The value of plant capability used to design a load shedding program should take into account the possibility that one or more generating units may be out of service when the overload incident occurs. This determination must be based on plant configuration and judgment. However, the following conditions should be considered.

- a) All units in operation.
- b) All but the largest unit in operation.
- c) All but the two largest units in operation.

1.2.4 REDUCED PLANT CAPABILITY. The reduction in plant capability resulting from underspeed operation should be known but will generally be unavailable. As an approximation, assume a capability loss of about four percent capability for each Hz of underfrequency.

1.2.5 LOAD REDUCTION REQUIREMENTS. In order to attain stable plant operation, load must be shed to such a degree that the total load served does not exceed plant capability. As already explained, the determination of plant capability must take into account the possibility that one or more generating units in the plant may be out of

service and also that the remaining plant may experience some loss of capability because of underfrequency operation.

1.2.5.1 RATE OF LOAD REDUCTION. Load must be shed fast enough to attain the required load reduction before plant frequency has deteriorated to an unacceptable level. The rate of frequency change can be estimated from the following formula:

$$R = pL(f_1 - f_0) / H(1 - f_1^2/f_0^2) \quad (\text{eq 1})$$

where:

R = Average rate of frequency change, Hz per second

p = Power factor of machine

L = Average per unit overload = (Load-Power Input)/(Power Input)

f₀ = Initial frequency, Hz

f₁ = Final frequency, Hz

H = Inertial constant of machine, MW sec/MVA

For a typical calculation, assume that a 100 MW, 0.85 power factor machine with an inertial constant of H=4 experiences a sudden overload to 120 MW and we wish to find the rate at which frequency drops from the initial frequency of f₀ = 60 Hz to f₁ = 58 Hz.

In this case:

$$L = (120 \text{ MW} - 100 \text{ MW}) / (100 \text{ MW}) = 0.20 \quad (\text{eq 2})$$

and substituting in Equation 1:

$$R = [(0.85)(0.20)(60-58)]/[4(1 - (60^2/58^2))] = - 1.21 \text{ Hz/second.}$$

In this case, the minus sign indicates that the frequency is decreasing at a rate of 1.21 Hz per second. The total time for the frequency to drop 2 Hz, from $f_0 = 60$ Hz to $f_1 = 58$ Hz would be:

$$\text{Time} = 2/1.21 = 1.65 \text{ seconds}$$

This indicates that the load shedding plan must accomplish a load reduction of at least 20 MW within 1.65 seconds. For calculations involving an entire plant, composite values should be used to obtain a rate of frequency drop for the entire plant. The composite inertial constant for the plant, H_{Plant} , is calculated from the following formula:

$$H_{\text{plant}} = (H_1MVA_1 + H_2MVA_2 + \dots + H_NMVA_N)/(MVA_1 + MVA_2 + \dots + MVA_N) \quad (\text{eq 3})$$

where the subscripts refer to the individual generating units.

1.2.5.2 TOTAL LOAD REDUCTION. The load shedding plan must accomplish a total load reduction sufficient to relieve the plant overload and also to provide a slight underload so that the plant will have reserve capability to reaccelerate to the normal

operating frequency. One must also take into account the loss of capability that results from underfrequency operation. In the previous example (a 100 MW generator with a 120 MW load) assume that the plant frequency dropped to 58 Hz before load shedding was initiated and that the plant capability loss was four percent for each Hz of frequency drop. In this case, the plant capability would be only 92 percent (or 92 MW) at 58 Hz. If 30 MW of load were shed (reducing the total load from 120 MW to 90 MW) then the generator would have a 2 MW margin (92 MW capability less 90 MW load) to reaccelerate back to the normal operating frequency of 60 Hz. The time to reaccelerate may be computed from the same formulas already given.

1.2.5.3 MINIMUM POWER SUPPLY. It is reasonable to design a load shedding plan to drop nearly all or perhaps even all of the plant load. The rationale is that even if all load is dropped but the plant is saved, load restoration would be faster and easier than if the plant were lost also.

1.3 METHODS OF LOAD SHEDDING. There are many methods of load shedding, both automatic and manual. The automatic methods include underfrequency relaying and various transfer-trip arrangements. All of these methods have relative advantages and disadvantages and the choice of the most advantageous method should be based on the specific conditions that prevail. However, load shedding by underfrequency relaying is the most common and generally the preferred method.

1.3.1 UNDERFREQUENCY RELAYING. The principal advantage of under frequency load shedding is that the underfrequency relays respond to the underfrequency condition resulting from generator overload. They do not respond to the overload directly, but to the deleterious conditions resulting from overload. Therefore, they respond only if the generators are suffering the adverse consequences of overload.

1.3.1.1 AUTOMATIC OPERATION. Load shedding with under-frequency relays is generally performed automatically; when frequency drops to a preset level, generally performed automatically. Automatic operation is generally advantageous because, with severe overloads, system frequency may drop faster than the plant operator can respond.

1.3.1.2 CRITICAL FREQUENCIES. In general, underfrequency relays are applied to shed load in two to five steps, with three-step load shedding being the most common. Each underfrequency relay is set to trip a block of load at progressively lower frequencies; for instance, at 59.5 Hz, 59.0 Hz, and 58.5 Hz. These critical frequencies should be computed as described previously.

1.3.1.3 INCREMENTAL LOAD REDUCTION. The amount of load to be shed at each critical frequency should be related to the expected percentage overload. In general, this determination can only be made in an approximate manner, because system loads vary and cannot be determined accurately in advance. It is important to note that with a multi-stepped underfrequency load shedding system, quite often the overload will be eliminated and system frequency will start to recover after only one or two critical frequencies are reached. Herein lies another advantage of underfrequency load shedding; with a well-designed load-shedding plan, only the minimum amount of load necessary for system recovery is shed.

1.3.2 TRANSFER TRIP LOAD SHEDDING. With transfer trip load shedding, protective relays and circuit breakers are interlocked so that the event that causes a loss of power supply also causes certain loads to be dropped, thereby preserving a balance between load and generation. For instance, with an interconnected plant, auxiliary contacts on the interconnection circuit breaker could be used to trip certain

loads whenever the interconnection failed. Similarly, for an isolated plant, the loss of one generating unit could be sensed and used to initiate the tripping of a block of load equal to the generating capacity lost. Although transfer trip load shedding has the advantage of simplicity, the use of this method will almost always result in greater loss of load than with underfrequency load shedding. For this reason, the transfer trip method is generally not recommended.

1.3.3 MANUAL LOAD SHEDDING. In general, manual load shedding cannot be used to resolve problems of severe plant overloads. With severe overloads, the system frequency drops too rapidly for an operator to respond and the plant can be lost within seconds. Manual load shedding is appropriate to relieve mild overloads; that is, overloads that are small enough to be accommodated by governor action (thereby preventing underspeed operation), but that are still large enough to cause excessive equipment stress (overheating, accelerated wear, etc.) if uncorrected. It is appropriate to combine manual load shedding (to relieve mild overloads) with underfrequency load shedding (to relieve severe overloads).

1.3.3.1 LOAD SHEDDING PLAN. With manual load shedding, it is appropriate to have a load shedding plan. This plan can be quite simple; it need consist of no more than a list of what loads (or feeders) should be tripped and how. It is important that the plan be prearranged so that the plant operator can implement it quickly under emergency conditions.

1.3.3.2 INCREMENTAL LOAD REDUCTION. In designing a manual load shedding plan, the total amount of load to be shed manually should be sufficient to relieve the anticipated plant overload. Manual load shedding can be performed in one or several steps to take account of varying system conditions, such as the difference between

summer and winter peaks or seasonal changes in plant capability because of scheduled maintenance.

1.3.4 POINT OF APPLICATION. In order to determine the point of application, local or remote, the designer must take into account the location of the specific loads to be shed and the electric distribution system configuration. This determination will also be influenced by the load shedding method; underfrequency, transfer trip, or manual.

1.3.4.1 LOCAL APPLICATION. When load shedding is initiated locally, that is, at the power plant, individual outgoing feeders are tripped. Generally, each feeder will be tripped sequentially in a predetermined order of preference until the overload has been corrected. Local load shedding is the system that is the most common and easiest to implement and can be utilized with underfrequency, transfer trip, or manual systems. A disadvantage is that, if a feeder is tripped, then all loads served from that feeder are dropped, regardless of their criticality. In some systems, all nonessential loads can be grouped on a single feeder, and this feeder is tripped first. In other systems, this approach may not be practical.

1.3.4.2 REMOTE APPLICATION. With remote application, individual loads are tripped rather than entire feeders. With this approach, each load can be given a priority and tripped sequentially in accordance with that priority. Remote tripping can be readily implemented with underfrequency relays installed at the remote circuit breaker. With manual or transfer trip load shedding, the trip signal must be transmitted to the remote circuit breaker.

1.4 ELECTRICAL USAGE AND CRITICALITY. In general, the least critical loads should be tripped first, and the load shedding should proceed in stages with

progressively more critical loads being shed at each stage. The following provides guidelines for the determination of the relative criticality of loads.

1.4.1 CRITICAL LOADS. To develop a load shedding plan, the critical loads shall be identified first, along with an estimate of the magnitude of each. The load shedding plan shall be designed so that critical loads are shed last. However, in some cases, it may be necessary to divide the critical loads into two or more categories and assign relative priorities to each category.

1.4.1.1 MISSION CRITICAL LOADS. Mission critical loads are the loads that are essential for the operation of the facility and, if shed, would adversely impact the facility mission. Mission critical loads may also include security.

1.4.1.2 LIFE SUPPORT LOADS. Life support loads include hospitals and similar facilities where loss of power may endanger life.

1.4.1.3 COST OF POWER OUTAGE. In some cases, a power outage, while not endangering the mission or life support, may result in excessive costs. For instance, the power supply to a food storage facility may be considered critical because a power outage may result in food spoilage with inherent loss of money and morale.

1.4.1.4 POLITICAL IMPLICATIONS. In some cases, the selection of critical loads must be made on a purely subjective basis, taking into account the effect on the community of providing power, or of not providing power, to a specific load during a widespread power failure.

1.4.2 TIME-CRITICAL LOADS. In many cases, load criticality will vary with time. These variations should be taken into account, if possible, when designing the load shedding plan.

1.4.2.1 SEASONAL VARIATIONS. In a severely cold climate, a load related to providing heat could be considered critical during the winter and noncritical during the summer. Under the same conditions, the power supply to a frozen food storage facility could be considered critical during the summer and non-critical during the winter.

1.4.2.2 DIURNAL VARIATIONS. The criticality of some loads may vary from day to night or from weekday to weekend because of changing usage. Examples may include auditoriums, theaters, and offices.

1.4.2.3 INTERRUPTIBLE LOADS. Some loads can withstand short interruptions but not lengthy interruptions. Examples may include community facilities with emergency (battery powered) lighting. These loads can be classified non-critical for load shedding, but could also be given a high priority for load restitution.

1.4.3 STANDBY POWER. In many cases, highly critical loads such as those identified as mission critical or life support will be provided with standby emergency power supplies (uninterruptable power supply, diesel generator, etc). In these cases, the load under consideration can be downgraded from critical to interruptible or even noncritical depending on the capability of the standby power supply.

1.4.4 NON-CRITICAL LOADS. Having identified all critical loads, those that remain

can be classified as non-critical and identified for first-step load shedding.

2. POWER PLANT COGENERATION

2.1 DEFINITION. Cogeneration is the simultaneous generation of electricity (or mechanical energy) and steam (or other thermal energy such as hot air or hot water) from the same fuel (or energy) source.

2.2 CYCLES. Cogeneration cycles consist of energy conversion equipment such as boilers, turbines, and electric generators arranged to produce both electricity and steam or other thermal energy.

2.2.1 BASIC CYCLE. The basic conventional cycle consists of a steam boiler and turbine, which drives either an electrical generator or other mechanical equipment, and from which steam is extracted or exhausted to environmental heating or processes.

2.2.2 COMBINED CYCLE. See Figure 1 for a typical cogeneration combined cycle. The combined cycle consists of a gas turbine which exhausts to a heat recovery steam generator (HRSG). The HRSG in turn produces steam to drive a steam turbine. Both turbines can drive a single or separate electrical generator. Low pressure turbine exhaust steam can be used directly for process or heating purposes or the steam can be otherwise condensed and returned to the HRSG.

2.3 EFFICIENCY. The overall efficiency of a cogeneration cycle is a ratio of all usable energy (electricity, steam, hot water, etc.) obtained from the cycle to the energy (fuel, solar, etc.) input to the cycle.

2.4 METHODS OF OPERATION

2.4.1 PARALLEL OPERATION. Under parallel operation, the cogeneration plant is electrically interconnected and synchronized with an electric utility distribution or transmission system, with both the cogenerator and electric utility generating electricity simultaneously. Under parallel operation, some electricity will be flowing either to or from the cogeneration system.

2.4.1.1 REASONS FOR PARALLELING

2.4.1.1.1 SELECTIVE USE OF ELECTRICAL ENERGY FROM THE ELECTRIC UTILITY BY THE COGENERATOR. The cogenerator purchases electrical energy during periods and in amounts as needed to supplement its cogeneration capabilities.

2.4.1.1.2 SALE OF EXCESS ELECTRICITY BY THE COGENERATOR TO THE ELECTRIC UTILITY. The cogenerator has a large heat demand for process use or environmental heating and can cogenerate electricity in excess of facility needs. The excess electricity generated is sold to the electric utility generally at a rate which is less than the generating costs; this is usually not economical.

2.4.1.1.3 PEAK SHAVING. Cogeneration is used to minimize demand charges from the electrical utility.

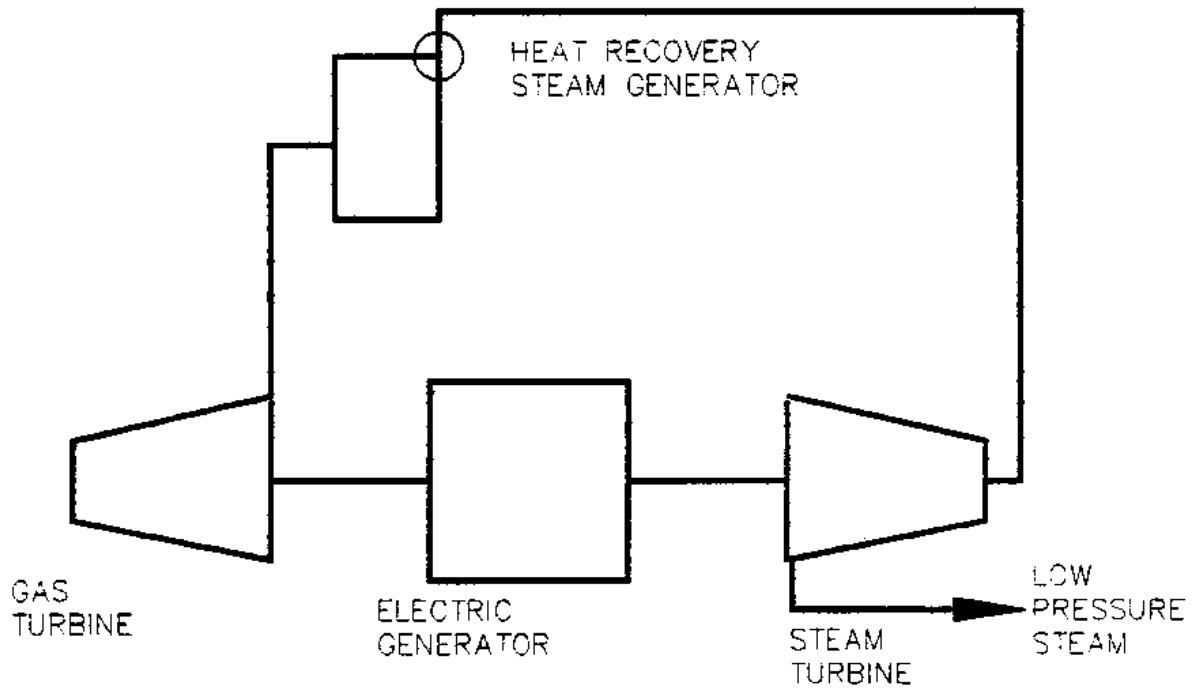

Figure 1
Combined cycle

2.4.2 ISOLATED OPERATION. Under isolated operation, the cogeneration plant generates, independently of the electric utility, all electricity and steam needed and used by the facilities that it serves.

2.4.2.1 REASONS FOR ISOLATION

- a) The facilities and cogeneration plant are in a remote location and electricity is not or cannot feasibly be made available from an electric utility to the facilities.

- b) Critical mission requires self-contained system, including onsite standby.

- c) Facility heat and electrical needs coincide to permit self-contained (total energy) cogeneration system.

- d) Agreement for parallel operation cannot be reached with electric utility.

2.4.2.2 ELECTRIC UTILITY CROSSTIE. A cogenerator may operate in isolation and may also be interconnected to an electric utility for service during maintenance down times and/or for standby service for use during an emergency outage of the cogeneration plant. If a cogenerator is not crosstied to an electric utility, backstart capability must be provided.

21.4.3 BASE LOAD THERMAL. In this mode of operation, the cogeneration equipment is sized and installed to generate electricity at a constant (base) load equal to that afforded by minimum steam demand, as determined from periodic swings in steam load. Supplemental electrical demands above the base load would be supplied by the electric utility through a parallel arrangement. Supplemental steam demands would be supplied by the use of supplementary firing of heat recovery steam generators or separate boilers.

2.4.4 BASE LOAD ELECTRIC. In this mode of operation, the cogeneration equipment is sized and installed to generate electricity at a constant (base) load equal to the minimum annual (or some other chosen period) electrical demand. Some of the electricity included in the base load may not be cogenerated but may serve to reduce

demand supplied by an electric utility. Because of the duality of steam production and utilization, automatic extraction condensing turbine generators lend themselves to base load electric operation.

2.4.5 ELECTRIC PEAK SHAVING. Peak shaving is accomplished by the use of onsite generation or cogeneration equipment to limit the demand, during peak electrical use periods, of electricity purchased from an electric utility through a parallel arrangement. Peak shaving is usually done on a daily cyclic basis. The objective of peak shaving is to economically reduce electric utility demand charges and overall electrical energy costs. If there is a high demand for steam during peak electric demand periods, cogeneration can be used to supplement purchased power to achieve peak shaving, if it proves to be economical.

2.4.6 ELECTRIC AND THERMAL TRACKING

2.4.6.1 ELECTRIC TRACKING. Electric tracking is defined as the continuous generation of electricity to meet the electrical demands of a facility as they occur throughout the daily load swings. With electric tracking, cogeneration equipment is used to generate as much steam as the electric load will allow with supplemental steam demands generated directly by use of boilers. The use of automatic extraction condensing turbine generators and combined cycles also provides the means for electric tracking.

2.4.6.2 THERMAL TRACKING. Thermal tracking is defined as the continuous generation of heat or steam to meet the thermal demands of a facility as they occur throughout the daily load swings. With thermal tracking, cogeneration equipment is used to generate as much electricity as the steam load will allow with supplemental

electrical demands generated on other equipment such as gas turbine generators, diesel generators, and steam turbine generators. Automatic extraction condensing turbine generators and combined cycles provide the means for simultaneous tracking of both electric and thermal loads.

2.5 INTERCONNECTION WITH UTILITY

2.5.1 OPERATION REQUIREMENTS. Operational requirements of a cogeneration plant interconnected with an electric utility are conditions of either the electric utility rate schedule for parallel generation contract service or separate contract of agreement between the cogenerator and utility. The conditions as set out in the contract may be site specific and cogeneration system specific. Typical examples are as follows:

- a) Voltage, frequency, and wave shape of alternating current to be delivered to the utility system shall be maintained within specified limits.

- b) The utility may reserve the right to limit the amount of electrical load delivered to the utility system at certain times and as utility electric operating conditions warrant.

- c) The utility may reserve the right to inspection, observation of testing, and specification of certain maintenance requirements.

- d) The cogenerator may be required to notify the utility prior to initial energizing and startup testing of the cogeneration facility.

e) The cogenerator may be required to notify the company prior to each start of energy delivery and interconnection to the utility system.

f) The utility may require that the cogeneration plant's scheduled outage for maintenance coincide with periods when utility power system demand is low.

g) The utility may require a demonstration of reasonable reliability of the cogeneration plant over the life of the contract.

h) The utility may require a contract specifying technical and operating aspects of parallel generation.

2.5.2.1 UTILITY STANDBY SERVICE. This arrangement requires a manual or automatic throwover switch that will first disconnect the cogeneration electrical source from the facility electrical load before connecting the facility electrical load to the electric utility service entrance line.

2.5.2.2 PARALLEL OPERATION. This arrangement requires two manually operated disconnect switches, one to disconnect or connect the cogeneration electrical source to the facility electrical load and the other to disconnect or connect the facility electrical load to the utility service entrance line. In addition to these switches, meters for billing will be required and are usually supplied, owned, and maintained by the electric utility. The manual switch for connect or disconnect of the utility service from the facility electric load and cogeneration system electric source is usually a mandatory contract

requirement by the utility. The utility will further require that this switch be under exclusive control of the utility, and that it must have the capability of being locked out by utility personnel to isolate the utility's facilities in the event of an electrical outage on transmission and distribution facilities serving the cogenerator. The other manual switch or isolation device will also usually be required by the utility contract to serve as a means of isolation for the cogeneration equipment during maintenance activities, routine outages, or emergencies. The interconnection with the utility for parallel operation also requires synchronizing controls for electrically synchronizing the cogeneration system with the electrical utility system.

2.5.3 LINE AND EQUIPMENT PROTECTION. Parallel operation introduces variables in distribution line protection in that fuses and other sectionalizing devices may be affected by generator contributions to fault currents. Line sectionalizing studies should be made to verify correct operation of sectionalizing devices over the range of conditions that could arise. Generators operating in parallel with the utility system need protection against overload. To protect both line and cogeneration equipment in the event of unacceptable fault, one protective relaying system is required to separate the utility system from the cogeneration bus and another protective relaying system is required to separate the cogenerator from the cogeneration bus. The required protective relay functions are usually designated by the electric utility and the final design of the complete protective relaying system must have the approval of the electric utility prior to initial operation of the cogeneration system.

2.5.4 UTILITY POWER RATES. Utility power rates are based on the utility's costs to provide both electrical capacity and energy. This is reflected in the billing as charges for electrical demand and energy.

2.5.4.1 DEMAND CHARGE. The electrical demand for billing purposes is usually determined from demand instruments located at the customer facility such as a kW meter and associated printing recorder which periodically records the kW load or demand. In some cases, the demand may be determined by tests made by the utility. Billing demand is usually established on a monthly basis and is taken as the highest demand recorded, usually in any 30-minute interval. Many utilities' rate schedules also contain a ratcheted demand clause which establishes a minimum billing demand based on the highest, or some percentage of the highest, demand occurring in the previous 12 months, or some other chosen period. The effect of the ratchet may result in a billing demand for a month of low demand, for instance a winter month, that is based on a high demand in a previous summer month. Rate schedules take various forms, depending on the utility and state public utility commission practices. Rate schedules for demand will vary according to geographic area and usage.

2.5.4.2 ENERGY CHARGE. The energy usage for billing purposes is determined from kWh meters located at the customer's facility. Energy charges are usually tied to billing demand in such a manner that low energy use at a high demand is charged at a high rate whereas a large energy use at a low demand is charged at a lower rate. Therefore any peak shaving scheme which can be used to reduce demand can result in savings which may economically justify the investment costs for peak shaving equipment and its fuel usage, operation, and maintenance. Rate schedules for energy will vary according to geographic area and usage.

2.5.4.3 TOTAL ELECTRIC BILLING. The electric billing by the electric utility is usually computed and issued on a monthly basis. The total electric bill will usually be the sum of the demand and energy charges plus adjustment for such items as fuel cost, research and development surcharge, and taxes.

2.5.4.4 OTHER FACTORS FOR SALE OF ELECTRICITY. The rates charged for electrical demand and energy depend on other factors or the type of service. These are typically as follows:

- a) Service at secondary voltage.
- b) Service at primary voltage (12,000 to 69,000 volts).
- c) Standby service.
- d) Breakdown service.
- e) Supplementary service.
- f) Seasonal service.
- g) Water heating.
- h) Space heating.

2.5.4.5 PURCHASE OF ELECTRICITY. For parallel operation with a cogenerator, electric utilities under certain terms and conditions, may purchase excess electricity generated by the cogenerator. As covered under section 201 of the Public Utility Regulatory Policy Act of 1978 (PURPA), cogeneration facilities that are not owned by an electric utility and that meet certain standards are eligible for special incentive rates to be paid to them by the utility as required under Section 210 of PURPA. These incentive rates that the utility is obligated to pay to qualifying facilities are not required directly by PURPA but are required by rules promulgated by the Federal Energy Regulatory Commission (FERC). These rules by FERC provide that electric utilities must purchase electric energy and capacity made available to the electric utilities by qualifying cogenerators at a rate that reflects the costs that the purchasing utility can avoid as a result of obtaining energy and capacity from these sources, rather than generating the energy itself or purchasing the energy or capacity from other suppliers. The term "avoided costs" has been defined by FERC as the costs to an electric utility of energy, capacity, or both, that but for the purchase from a qualifying facility, the electric utility would generate or construct itself or purchase from another source.

"Avoided costs" include the fixed and running costs on a utility system that can be avoided by obtaining energy or capacity from a qualifying facility. An electric utility's "avoided costs" are primarily fuel cost for production of energy and capital cost of facilities for generation capacity. The amount a utility will pay a cogenerator for purchased electricity produced by the cogenerator is equal to or is a percentage of the utility's "avoided cost" as decided by agreement contract between the utility and cogenerator, or as set out in a rate schedule published by the utility.

2.6 ECONOMICS. Cogeneration plants are capital intensive and high maintenance facilities. However, cogeneration can be economically justified if the savings in electrical energy costs, resulting from the use of cogeneration as compared to purchase of electricity from a utility, offset the costs of the cogeneration facility capital investment, added fuel usage, added operation, and added maintenance.

2.6.1 FUEL SAVINGS. Using cogeneration, there is no fuel saving when compared to the use of boilers for the production of steam for process or environmental heating/cooling systems. There is a fuel saving for production of electricity, by use of cogeneration as compared to non-cogeneration systems, if the exhaust heat or steam from the prime mover is used by other process or environmental heating/ cooling systems.

2.6.2 COMPETITIVE SYSTEMS. The basic cogeneration systems that provide the means to utilize exhaust heat from the prime mover are the back pressure steam turbine, gas turbine, combined cycle, or reciprocating combustion engine. A cogenerator using only condensing turbine generator equipment cannot compete economically with an electric utility using the same type of equipment because of the economics of large scale operations. The utility's large condensing steam turbine generators operating at high initial pressure and temperature are much more efficient

than would be a cogenerator's small condensing steam turbine generators operating at lower initial pressures and temperatures. However, condensing steam turbine generators can be economically combined with noncondensing or extraction turbine generators if the noncondensing equipment is utilized to the extent that fuel savings more than offset the increased cost of operation of the condensing equipment. The noncondensing and condensing equipment may be combined into single machines such as automatic extraction condensing turbine generators.

2.6.3 POWER TO HEAT RATIO. A gauge for match of the cogeneration system with the facility heat or steam and electric demands is often expressed as the power to heat ratio. This ratio is defined as the ratio of the power generated to heat available for process or environmental heating/cooling systems. The higher the power to heat ratio, the higher will be the efficiency of cogeneration or economic return on investment capital. Table 1 shows typical power to heat ratios of cogeneration systems.

2.6.4 ECONOMIC VARIABLES. The application of cogeneration to a facility is site specific insofar as economic evaluation is concerned. The evaluation will require complete information for the facility concerning electricity and steam (or heat) usage and load demand on an hourly basis throughout a typical year. The annual costs of fuel and purchased electricity must be determined for each alternate system to be considered, including an alternate without cogeneration. Also, for each alternate system considered, a determination must be made of total capital investment cost, annual operating costs, and annual maintenance labor, parts, and material costs. Depending on the type of evaluation used, periodic replacement costs and salvage value may need to be determined.

2.6.5 ECONOMIC EVALUATION. The economic evaluation of the various alternate systems is best done on a life cycle cost basis and by a present worth type analysis. For a complete description of life cycle costing, modes of analysis, methods and

procedures for analysis, and choice of most economical alternate, refer to National Bureau of Standards Handbook 135, Life-Cycle Cost Manual for the Federal Energy Management Programs.

	Backpressure Turbine Generator	Gas Turbine	Combined Cycle ¹	Diesel Generator
kWh/million Btu steam	50 to 1	200 to 1	250 to 1	400 to 1
Btu power/Btu steam	0.171	0.683	0.853	1.365

¹ Gas turbine, steam generator, and backpressure turbine generator

Table 1
Typical performance of cogeneration systems power to heat ratio