



**PDHonline Course M526 (2 PDH)**

---

# **An Introduction to Cooling Tower Water Treatment**

*Instructor: J. Paul Guyer, P.E., R.A., Fellow ASCE, Fellow AEI*

**2020**

**PDH Online | PDH Center**

5272 Meadow Estates Drive  
Fairfax, VA 22030-6658  
Phone: 703-988-0088  
[www.PDHonline.com](http://www.PDHonline.com)

An Approved Continuing Education Provider

# **An Introduction to Cooling Tower Water Treatment**

*J. Paul Guyer, P.E., R.A.*

## **CONTENTS**

- 1. TYPES OF COOLING WATER SYSTEMS**
- 2. COOLING TOWER WATER CALCULATIONS**
- 3. OBJECTIVES OF COOLING WATER TREATMENT**
- 4. MICROBIOLOGICAL DEPOSITS AND CONTROL**
- 5. CORROSION IN COOLING SYSTEMS**
- 6. DEVELOPING AN EFFECTIVE COOLING WATER TREATMENT PROGRAM**
- 7. COOLING WATER SYSTEM START-UP AND LAYUP REQUIREMENTS**

(This publication is adapted from the *Unified Facilities Criteria* of the United States government which are in the public domain, have been authorized for unlimited distribution, and are not copyrighted.)

**1. TYPES OF COOLING WATER SYSTEMS.** Cooling water systems remove heat generated from a variety of industrial processes. There are three basic types of cooling water systems: once-through, open recirculating, and closed recirculating cooling water systems. This publication describes once-through and open recirculating systems.

**1.1 ONCE-THROUGH COOLING WATER SYSTEMS.** Once-through cooling water systems use cool water that circulates only once through the entire system before being discharged. This type of system is commonly found along rivers or coastlines where abundant water is available for use. The system contains heat exchange equipment and transfer piping, as shown in Figure 1. Power utility services often use this type of system.

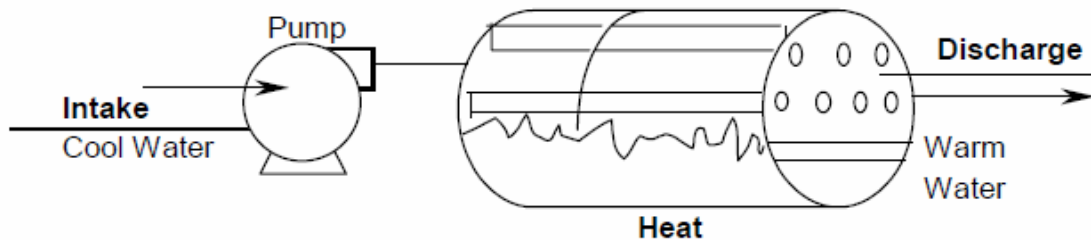

Figure 1

Once-through cooling water system diagram

**1.2 OPEN RECIRCULATING COOLING WATER SYSTEMS.** Open recirculating cooling water systems are open to the atmosphere and continuously recycle and reuse the cooling water. These systems are composed of an evaporator unit, a cooling tower, or an evaporative condenser. These units mix air and water and allow some of the water to evaporate, cooling the balance of the water volume. The cooled water is then circulated to heat exchangers or chillers, where heat is added to the cooling water thereby removing heat from the process flow stream. The warmed water is then circulated to the cooling tower, where the cycle is repeated. Water is lost from the system primarily through evaporation; however, a portion of the cooling water must be

discharged as waste (i.e., blowdown) to maintain a suitable water quality within the system. All water lost from the system is replaced by makeup water. Recirculating cooling water systems are found in most air conditioning chiller operations, as well as many heat exchange operations. Evaporative fluid coolers and evaporative condensers are terms defining open recirculating cooling water systems that use evaporators, which are slightly different than a cooling tower and do not send the cooled water out of the evaporative unit itself. An evaporative cooler cools a circulating fluid that does not change phase (e.g., does not condense from a gas to a liquid). An evaporative condenser cools a circulating fluid from a gas into a liquid, such as a refrigerant. The hot fluid that is to be cooled is brought to the unit. Figure 2 shows a typical evaporative cooler and evaporative condenser diagram; Figure 3 shows a typical open recirculating cooling water system; and Figure 4 shows a typical cooling tower system.

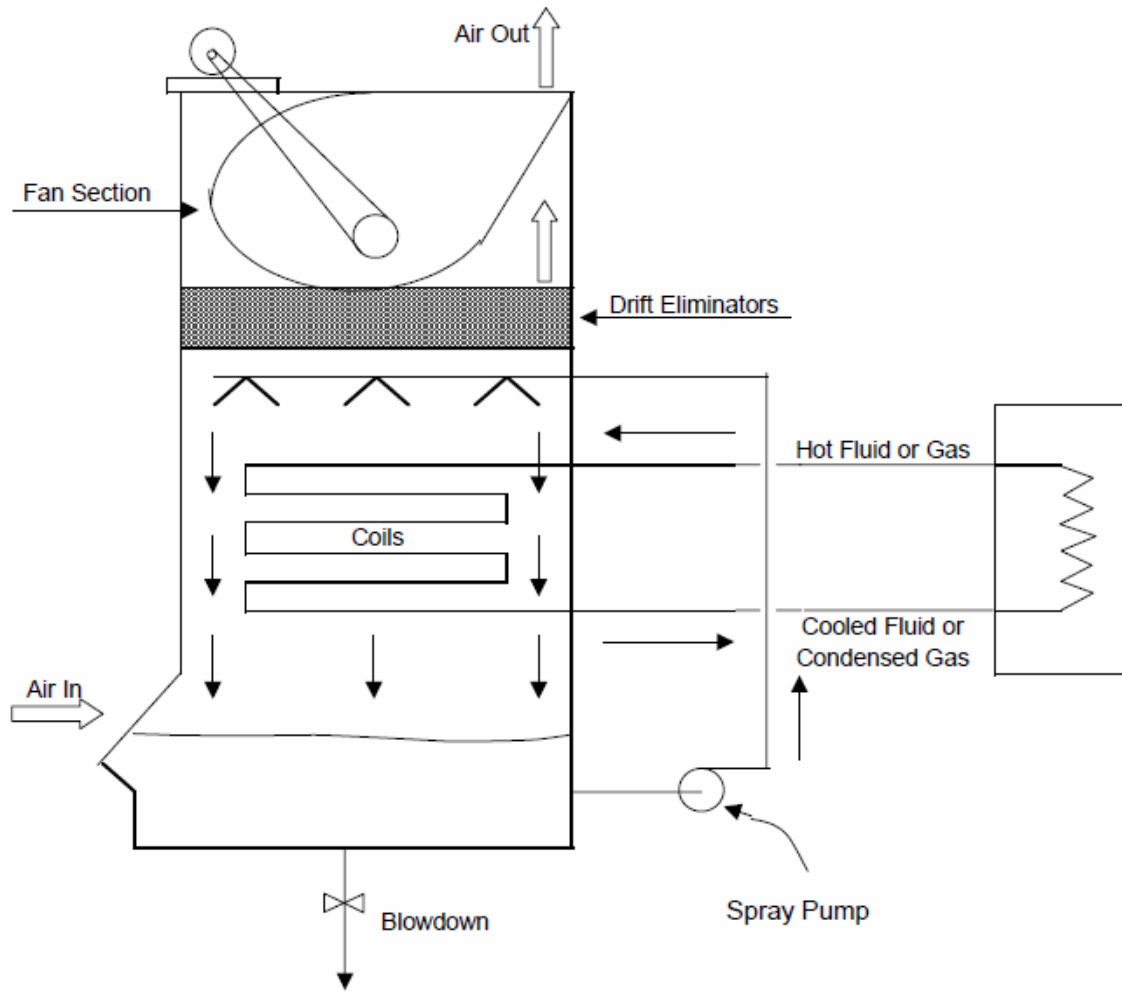

Figure 2  
Evaporative fluid cooler and evaporative condenser diagram

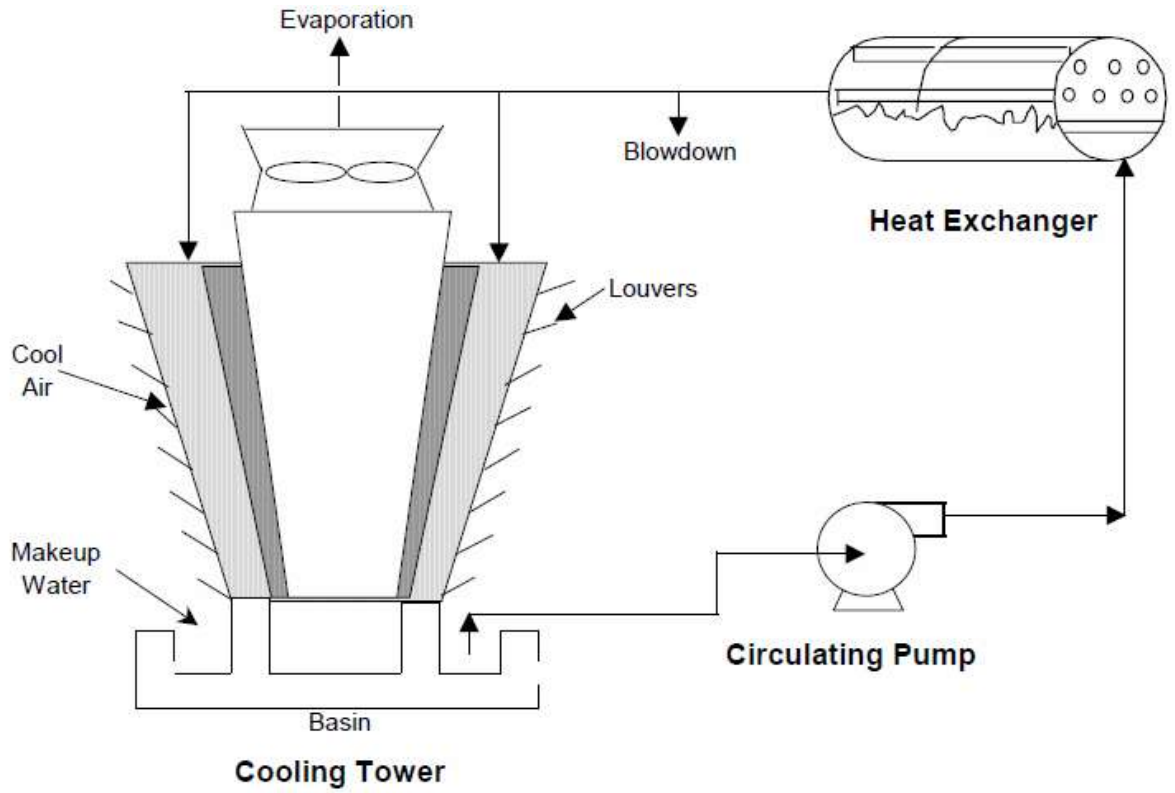

Figure 3

Open recirculating cooling tower water system diagram

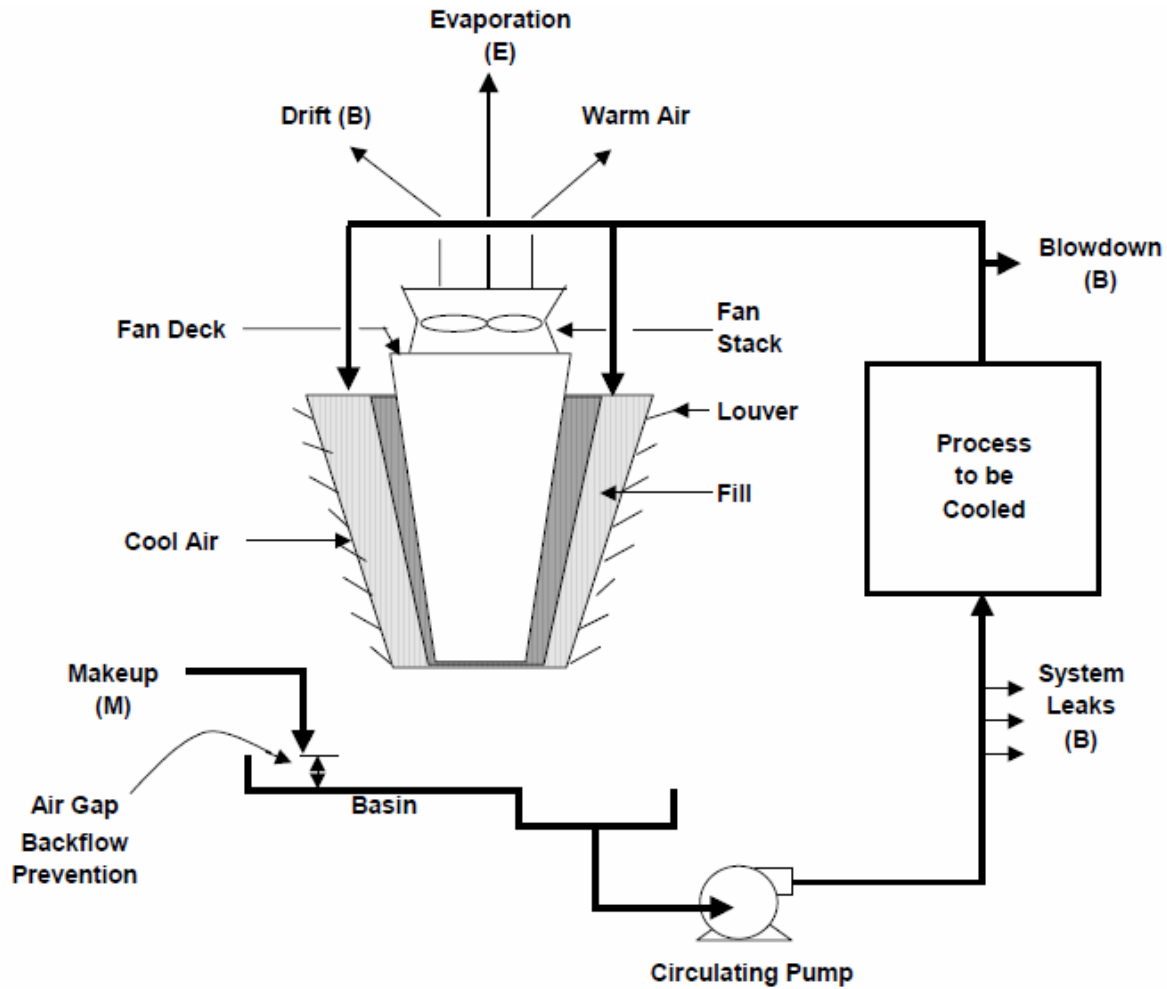

Figure 4  
Cooling tower water system

**1.3 TYPES OF COOLING TOWERS.** Types of cooling towers include natural draft, induced draft, and forced draft.

**1.3.1 NATURAL-DRAFT TOWERS.** In natural-draft towers, airflow through the tower is achieved naturally (i.e., without any mechanical means such as fans). Air flows across the falling water and up through the cooling tower as a result of the differential density between the lighter, heated and humidified, air within the tower and the cooler and dryer outside air. Fitting the tower with spray nozzles, which create more mixing of air and water droplets and improve the evaporation efficiency, produces increased water-cooling rates.

Large utility power plants use these large natural-draft cooling towers, which are called hyperbolic cooling towers due to their hyperbolic shape (see Figure 5).



Figure 5

Hyperbolic natural-draft cooling towers

**1.3.2 FORCED-DRAFT TOWERS.** The term “forced draft” denotes that air is forced or blown by fans into the cooling tower and up through the flow of falling water in the cooling tower. Drift eliminators are installed to prevent water entrained in the air from leaving the system.

**1.3.3 INDUCED-DRAFT TOWERS.** The term “induced draft” denotes that air is drawn by fans through the flow of falling water and up and out of the cooling tower. The airflow can be drawn either cross-flow or counter-flow with respect to the orientation of the falling water, resulting in either a cross-flow tower or a counter-flow tower. Drift eliminators are



also present. (See Figures 1.6, 1.7, 1.8, and 1.9 for diagrams and photos of cross-flow and counter-flow cooling towers.)

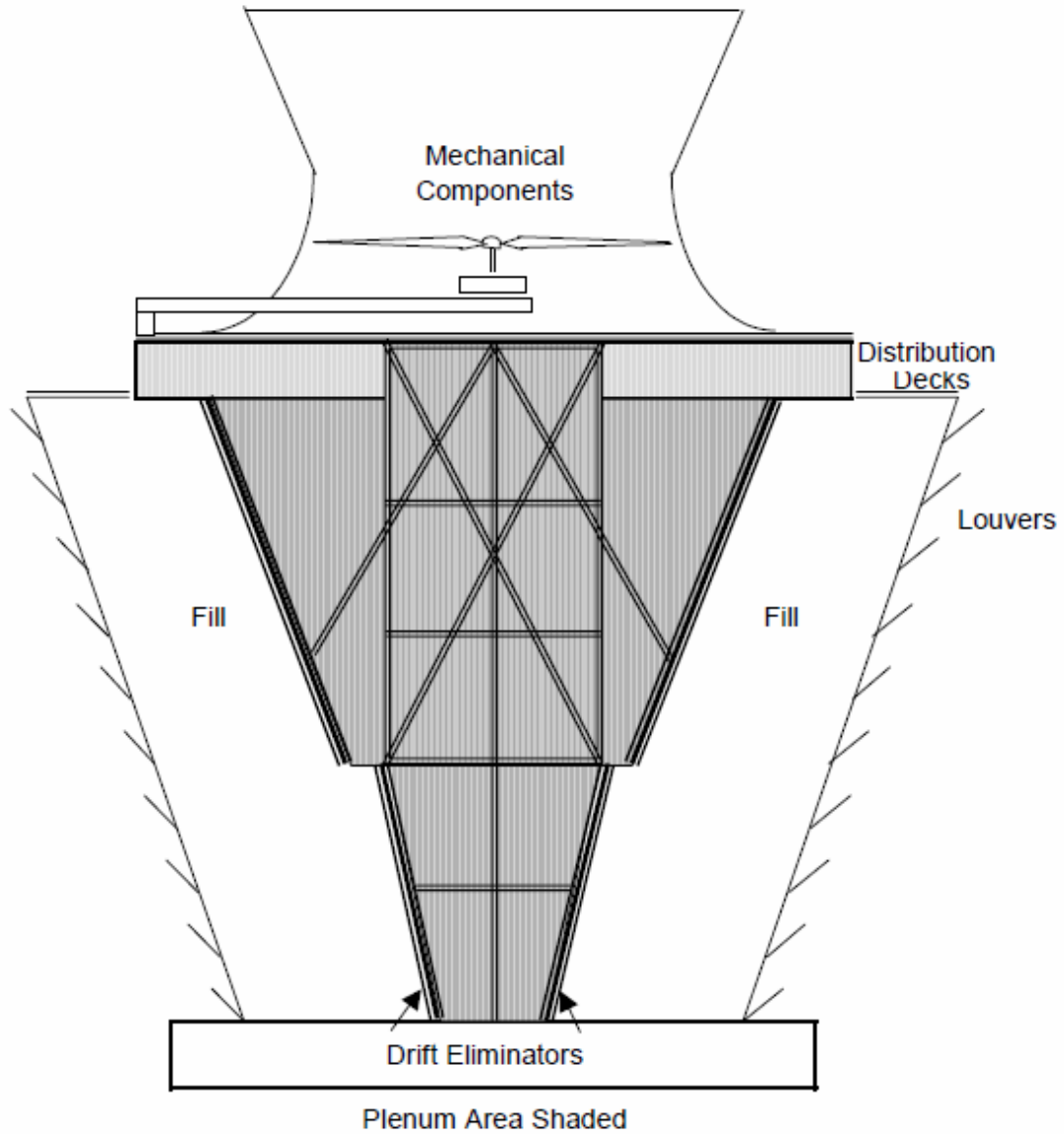

Figure 6  
Cross-flow cooling tower



Figure 7  
Cross-flow cooling tower

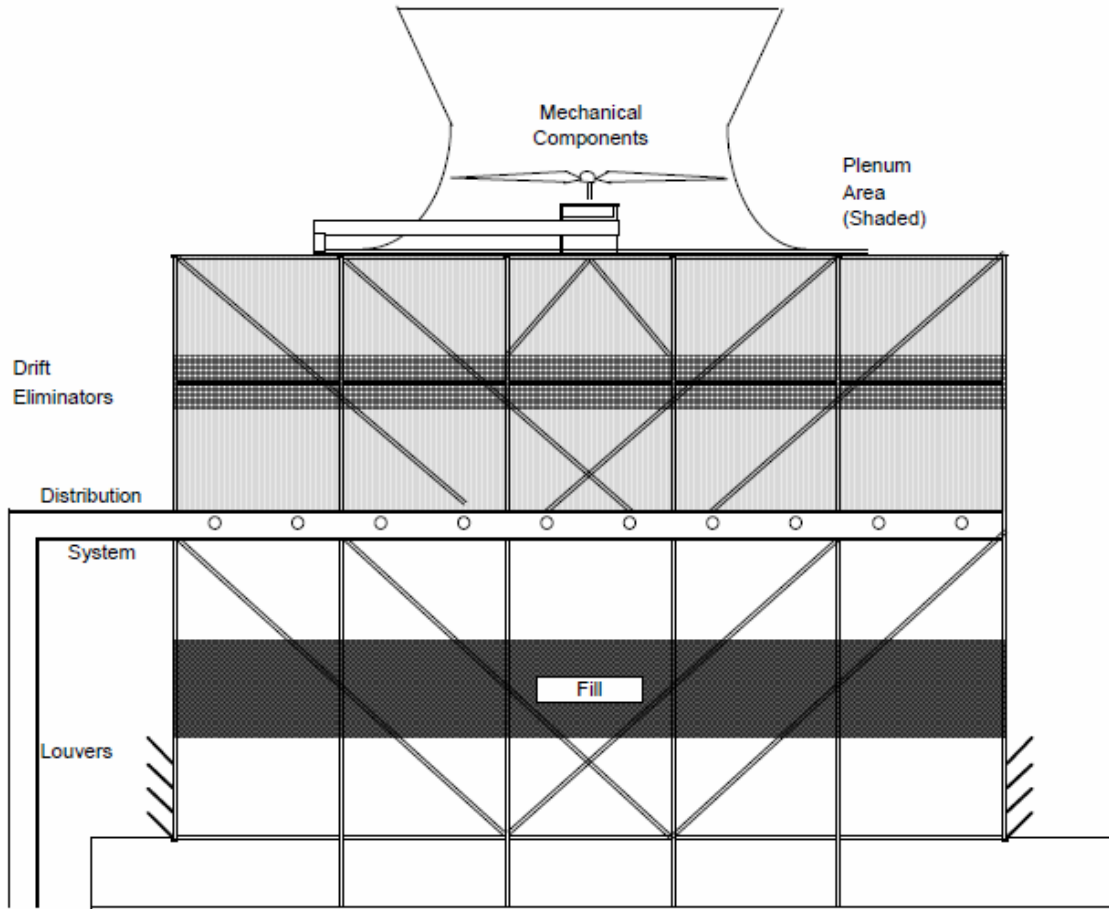

Figure 8  
Counter-flow cooling tower diagram



Figure 9  
Counter-flow cooling tower

**1.3.4 TYPICAL COOLING TOWER INSTALLATIONS.** Cooling towers are commonly of the induced-draft, cross-flow variety, although counter-flow and forced-draft cooling towers are also represented. The cooling towers range in size from small to large capacity.

**1.4 COMPONENTS OF A COOLING TOWER.** Figure 10 shows a simple diagram of a 1-fan, induced-draft, cross-flow cooling tower. The major parts of the tower include the basin and cold well, louvers, fill, water distribution (and fan) deck, drift eliminators, fan and fan discharge, and the endwall casings.

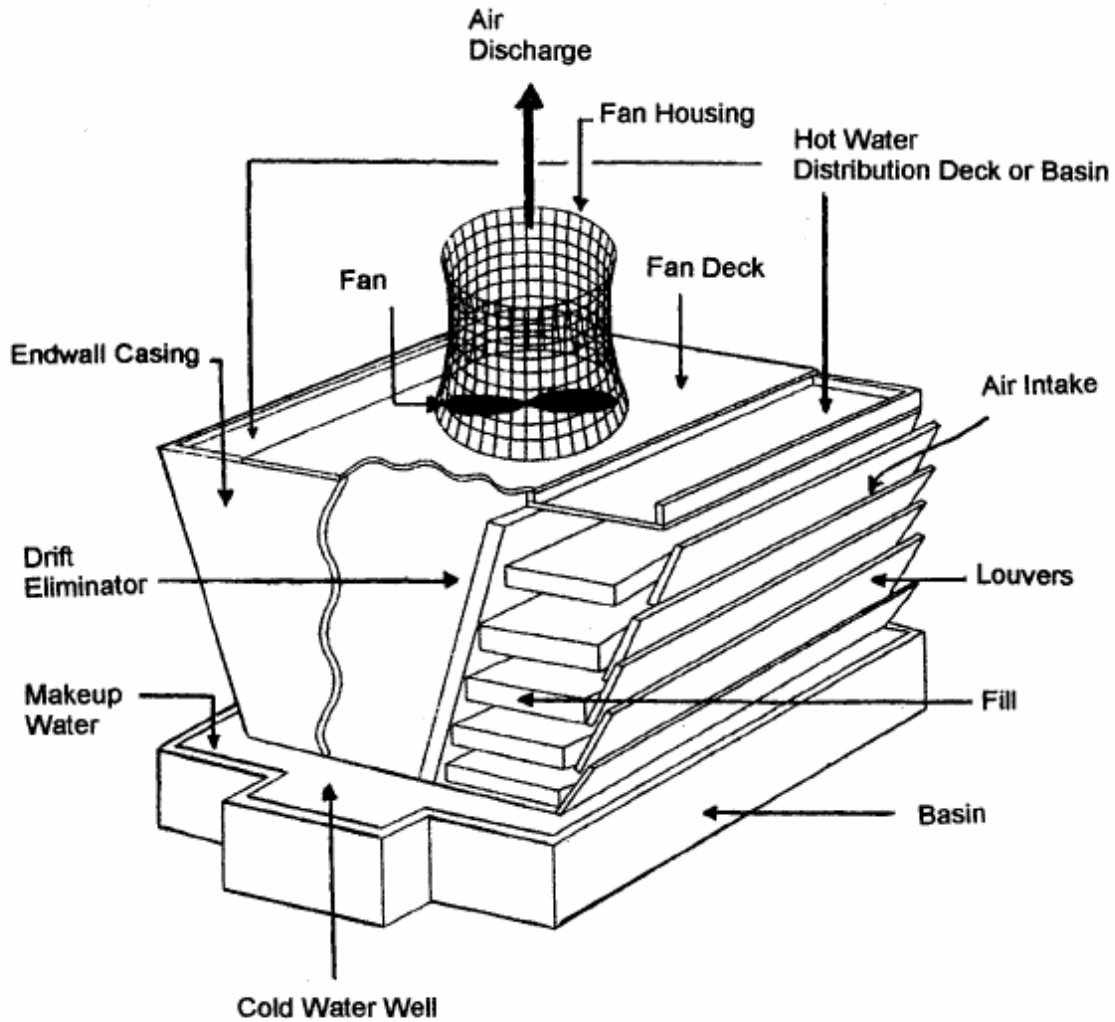

Figure 10

Induced-draft cross-flow cooling tower components

**1.4.1 BASIN AND COLD WELL.** The basin is that portion of the cooling tower structure located under the tower that is used for collecting cooled water and which can be used as a location for adding makeup water. The cold well is a deepened portion of the basin that contains submerged water circulation pumps. The basin may be constructed of concrete, wood, metal, or fiberglass.

**1.4.2 LOUVERS.** Louvers are flat or corrugated members constructed of wood, plastic, cement board, or fiberglass, and installed across (horizontally) the open side of a

tower. The main function of louvers is to prevent water from splashing out of the cooling tower through the openings where air enters the tower. Louvers are usually set at an angle to the direction of airflow.

**1.4.3 FILL.** Fill is the internal part of a tower where air and water are mixed. The fill intercepts the downward fall of water. The water is mixed with the air contained in the fill material and water is evaporated and cooled. There are two types of fill: splash fill and film fill. The falling water hits the splash fill, splashes, and breaks up into smaller water droplets, resulting in an increased rate of evaporation. The splash fill is made of wooden slats or bars, plastic, or ceramic tile. Film fill is a compact plastic material, similar to a honeycomb, that causes water to flow over the fill material, creating a large wet surface that maximizes evaporation as air travels past the film surface (see Figure 11).



Figure 11  
High-efficiency cooling tower film fill

**1.4.4 DRIFT ELIMINATORS.** The drift eliminators efficiently remove water droplets from the air and return the recovered water to the cooling tower, thereby minimizing the loss of cooling tower water. They are located in areas that are situated after the fill and water sprays and just before the area where the air exits the cooling tower (see Figures 6 and 8). Drift eliminators are also known as “mist eliminators.”

**1.4.5 WATER DISTRIBUTION AND FAN DECK.** In a cross-flow cooling tower, the hot water basin is used to distribute the warm return water flow uniformly over the tower fill (see Figure 6). In a counter-flow cooling tower, water sprays are used to distribute the warm water (see Figure 8). The fan deck supports the motor and fan of the water spray system. The stack is the structure (typically a cylinder) that encloses the fan and directs warm, humid discharge air upward and out of the cooling tower.

**1.4.6 CELL.** This is the smallest subdivision of a large cooling tower in which the fan can operate as an independent unit. A midwall casing must separate each end of the cell from the adjacent cells to ensure all air flow induced by the cell fan is drawn only through the cell fill and mist eliminator air path. Figure 7 illustrates a typical three-cell cross-flow cooling tower. Figure 9 illustrates a typical four-cell counter-flow cooling tower.

**1.5 COMMON COOLING WATER SYSTEM PROBLEMS.** Water-related problems can cause system downtime, loss of equipment efficiency, the need for capital replacement of equipment, and can increase the risk of disease from pathogenic microorganisms. An open recirculating cooling tower system has a greater potential for these problems than does a once-through cooling water system, due to the air- and water-mixing design of the open recirculating system. These problems are associated with water-caused deposits, corrosion, or microbiological organisms, and occur for various reasons:

- The cooling tower is essentially a huge air scrubber that can introduce materials such as microorganisms, gases, dust, and dirt into the circulating water, which provides an excellent growth environment for pathogenic microorganisms. These materials can contribute to the formation of deposits and cause corrosion.
- If the water is not properly treated and its quality maintained, corrosion and scale and solids deposition can occur. The potential for these problems results from the nature of the cooling system design and the operating conditions, including water evaporation, mineral concentration, and water temperatures of up to 54 °C (130 °F).
- The constant addition of makeup water results in increased quantities of mineral constituents that can form scale, deposits, and corrosion. Blowdown control and proper water treatment can minimize these problems.
- The film fill contains small water and air passages that can become plugged, thereby causing a reduction in cooling tower operational efficiency due to reduced water evaporation (see paragraph 1.4.3).
- Current designs for heat exchangers and cooling towers provide for more efficient operation than in the past, but unexpected water problems may occur. Some of the more prevalent potential problems are described in paragraphs 1.5.1 through 1.5.4.

### **1.5.1 ENHANCED AND SUPER-ENHANCED CHILLER CONDENSER TUBING.**

Recent air conditioning chiller equipment designs incorporate enhanced and super-enhanced chiller condenser tubes. Previous designs have used smooth-bored waterside condenser tubing. The enhanced tube is machined with rifled grooves that provide an increased surface area and a resultant increase in heat transfer; however, the rifled grooves and ridges tend to entrap SS (i.e., dirt, silt, sand, and old corrosion



products), which are deposited from the cooling water as it passes through the tube. This deposition of material on metal surfaces can create a type of localized corrosion called “under-deposit corrosion.” This situation has resulted in numerous cases of tube failure. The super-enhanced chiller tubes have even finer grooves and ridges, making this type of tubing even more susceptible to under-deposit corrosion. (See Figures 12 and 13, which show photos of super-enhanced copper tubes.)



Figure 12  
Super-enhanced copper tubes

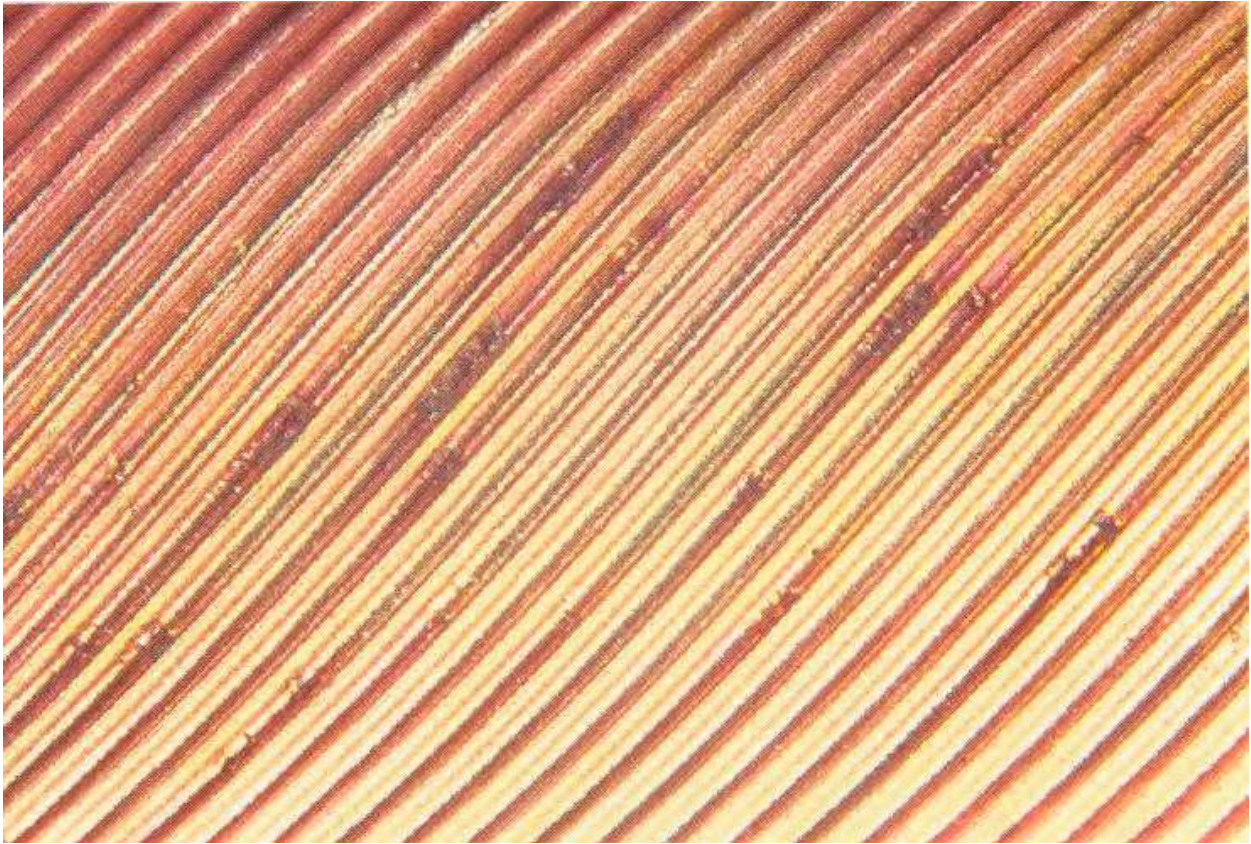

Figure 13

Close-up of corrosion pitting on super-enhanced copper tube

**1.5.2 WHITE RUST.** Some cooling towers are constructed with galvanized steel components and must not be exposed to conditions of high pH (high alkalinity). The galvanizing process deposits a protective zinc coating on a mild steel metal surface, resulting in increased resistance to corrosion. Failure to avoid such exposure can result in production of “white rust” due to the corrosion of the galvanizing coating. Eventually, this corrosion process exposes the mild steel underneath, which then starts to corrode. White rust failures have been a common occurrence throughout the country, mainly with newer cooling towers. Proper protection of the galvanizing material is necessary both during startup of a new cooling tower and during normal operations. Specific water treatment chemicals are needed to provide this protection. Examples include pretreatment with a high level of orthophosphate.

**1.5.3 COOLING TOWER FILM FILL.** Small- and medium-sized cooling towers use film fill, which is a tightly packed media as compared to the splash-type fill used prevalently in the past (see paragraph 1.4.3 and Figure 11). Film fill has a higher potential for fouling (plugging) due to adherence and entrapment of biomass and of SS (i.e., dirt, silt, and sand). The cooling capacity of a cooling tower can be reduced if the film fill is extensively fouled (see Figure 14). Instances of severe fouling have resulted in the collapse of fill into the cooling tower basin. In addition, fouling deposits in the fill can harbor pathogenic microbiological organisms such as Legionnaires' Disease.



Figure 14  
Heavily Fouled Cooling Tower Film Fill

**1.5.4 LEGIONELLA BACTERIA.** This type of bacteria is the cause of Legionnaires' Disease. It can grow in cooling water systems even when a proper microbiological control program has been maintained. This bacterium can be discharged in the drift

produced from all types of cooling tower systems. If a susceptible person inhales the bacteria, the disease could possibly develop. Due to increased awareness by cooling tower operators and the water treatment industry in general, the risk of being infected by Legionella Pneumophila or other pathogenic microorganism from a cooling tower system is probably not much greater today than it was a few years ago. Still, a number of outbreaks of Legionnaires' Disease are reported each year throughout the country. See paragraph 1.4.7 for more information on controlling Legionella.

## **2. COOLING TOWER WATER CALCULATIONS**

**2.1 PRINCIPLES OF COOLING TOWER SYSTEM OPERATIONS.** The function of a cooling tower is to dissipate heat from water-cooled refrigeration, air-conditioning and industrial process systems. Water is typically the heat transfer medium used to dissipate the heat. A cooling tower uses a combination of heat and mass transfer (evaporation) to cool the water flowing through the tower. Conductive heat transfer accounts for 20 to 30% of the total heat dissipated. The remaining 70 to 80% of total cooling is the result of evaporative cooling of about 1 to 2% of the recirculating water, depending on the decrease in temperature across the tower. It takes approximately 2,326,000 joules to evaporate 1 kilogram of water (1000 BTU per 1 pound of water). If this amount of heat is extracted from 454 kilograms (1000 pounds) of water, approximately 0.45 kilogram (1 pound) of water will be evaporated and the temperature will drop 0.55 oC (1 oF). If 4.5 kilograms (10 pounds) of water are evaporated, the water temperature will drop 5.5 oC (10 oF). The water lost by evaporation is replaced with makeup water. Water is also added to replace water lost through tower drift (loss of water from the tower as a fine mist), leaks in the system (unintentional blowdown), and water discharged as intentional blowdown. Water that is added to the cooling tower to replace all of these losses is known as cooling tower makeup water.

### **2.1.1 RELATIONSHIP BETWEEN EVAPORATION, BLOWDOWN, AND MAKEUP.**

The operation of cooling towers can be described by the relationship between evaporation, blowdown, and makeup. Makeup water must equal blowdown water plus water evaporation to maintain a constant operating water level in the system:

EQUATION |  $M = B + E$

where

M = makeup water, liters/sec (gpm)  
B = blowdown, liters/sec (gpm) (all sources)  
E = evaporation, liters/sec (gpm)

NOTE: Blowdown (B) includes discharge to sewer, drift loss, and any leaks from the system.

EXAMPLE: M = 6.3 liters/sec (100 gpm)  
B = 0.63 liters/sec (10 gpm)  
E = 5.67 liters/sec (90 gpm)

**2.1.2 CYCLES OF CONCENTRATION (COC).** One of the common terms used in describing the water use efficiency of cooling tower water systems is COC. COC represents the relationship between the makeup water quantity and blowdown quantity. COC is a measure of the total amount of minerals that is concentrated in the cooling tower water relative to the amount of minerals in the makeup water or to the volume of each type of water. The higher the COC, the greater the water use efficiency. Most cooling tower systems operate with a COC of 3 to 10, where 3 represents acceptable efficiency and 10 represents very good efficiency. It has been found that the range of 5 to 7 COC represents the most cost-effective situation.

**2.1.2.1 CALCULATING COC BY VOLUME.** If both makeup and blowdown water volumes are known, COC by volume can be calculated. The term is defined as:

EQUATION |  $C = M \div B$

where

- C = COC, no units
- M = makeup water, kg/hr (gpm)
- B = blowdown losses, kg/hr (gpm)

EXAMPLE: M = 6.3 liters/sec (100 gpm)  
 B = 0.63 liters/sec (10 gpm)  
 C = M ÷ B = 10

**2.1.2.2 DETERMINING COC BY WATER ANALYSES.** To determine COC, you must know the mineral content of both makeup and blowdown water. For example, you must determine both the conductivity of the recirculating cooling tower water and the conductivity of the makeup water. (Note that the blowdown water will have the same conductivity as the recirculating water.) Conductivity is commonly measured in micromhos ( $\mu\text{mhos}$ ). You can also estimate COC by using other water quality parameters such as chlorides, silica, or sulfates. The relationship is represented by this equation:

EQUATION |  $C = \frac{B_{\mu\text{mhos}}}{M_{\mu\text{mhos}}}$  or  $\frac{B_{\text{Cl}}}{M_{\text{Cl}}}$

where

- C = COC, no units
- $B_{\mu\text{mhos}}$  = conductivity of blowdown (recirculating water), micromhos ( $\mu\text{mhos}$ )
- $M_{\mu\text{mhos}}$  = conductivity of makeup water,  $\mu\text{mhos}$
- Cl = chlorides in blowdown, ppm
- Cl = chlorides in makeup water, ppm

**EXAMPLE 1:** The measured conductivity of the blowdown (recirculating water) is 800 micromhos and the makeup is 300 micromhos.

The COC is:

$$C = \frac{\mu\text{mhos}}{\mu\text{mhos}}$$

$$C = 800 \div 300 = 2.67$$

NOTE: The parameters of conductivity or chloride concentration are used commonly for such measurements. Other water quality parameters can be used, but sometimes with inaccurate results (i.e., calcium, magnesium, alkalinity, and silica can form deposits, meaning they drop out of solution). COC based on these parameters could be considerably less than that based on conductivity or chlorides. Similarly, chemical additions of sulfuric acid can yield higher sulfate levels than those species cycled up naturally.

**2.1.2.3 CONTROLLING COC.** A simple, sometimes overlooked rule: To increase COC, decrease blowdown; to decrease COC, increase blowdown.

**2.1.2.4 RELATIONSHIP BETWEEN COC AND MAKEUP.** COC and makeup requirements are related to the temperature drop across a cooling tower and to the recirculating rate of the tower. As shown in Figure 15, for a recirculating tower with water temperature drops of 5.5 °C (10 °F), 11 °C (20 °F), and 16.5 °C (30 °F), the makeup water requirement decreases rapidly as COC is increased to about 4 or 5, with lower incremental reductions at higher COC; therefore, COC can be adjusted (increased) to allow for reductions in water use (water conservation) and for reductions in the amount of water treatment chemicals used.



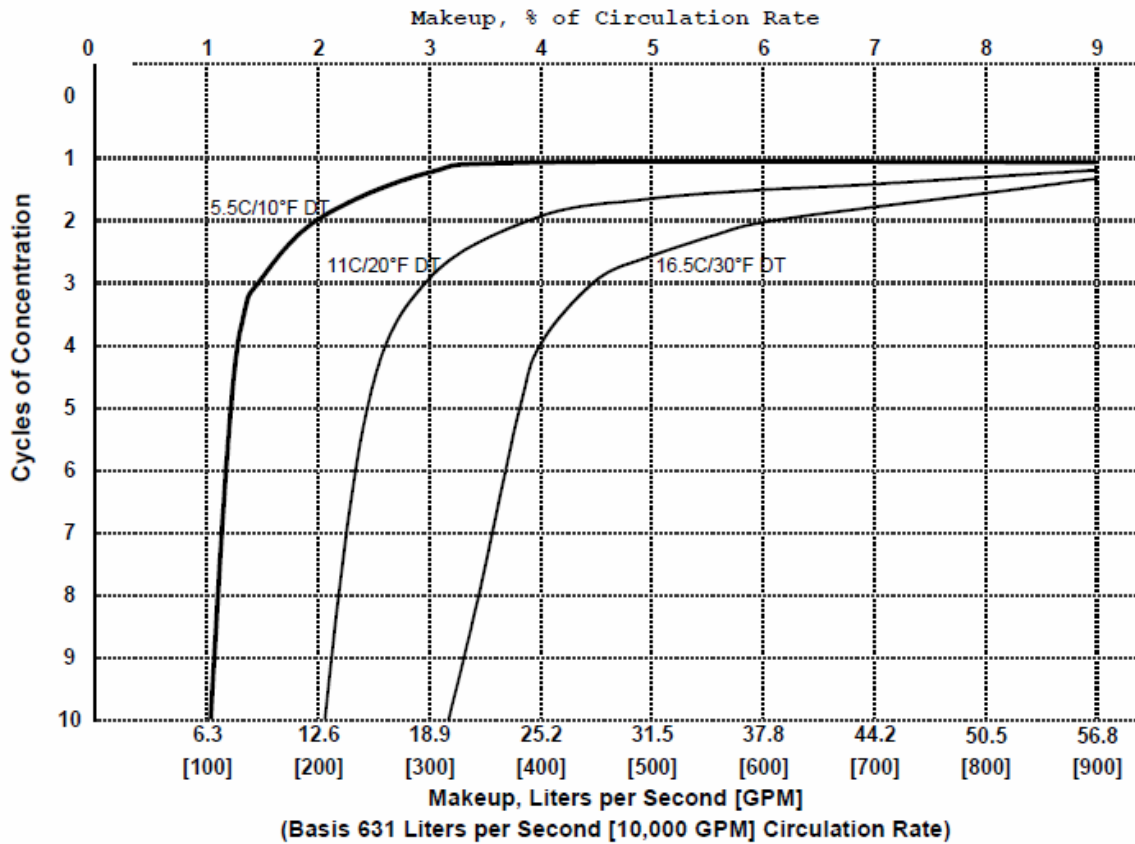

Figure 15

Effect of COC on makeup requirement

**2.1.3 RELATIONSHIP BETWEEN BLOWDOWN, EVAPORATION, AND COC.** You can use the cooling water evaporation loss to calculate the blowdown rate that must be maintained to operate at a selected COC. The relationship between blowdown, evaporation, and COC is represented with this equation:

EQUATION |  $B = E \div (C - 1)$

where

B = blowdown, liters per day or liters per second (gpd or gpm)

E = evaporation, liters per day or liters per second (gpd or gpm)

C = COC, no units

EXAMPLE: A cooling tower evaporates 37.8 liters per second (600 gallons per minute) and operates at 4 COC:

$$\text{EQUATION} \quad | \quad B = 37.8 \text{ l/sec (600 gpm)} \div (4-1) = 12.6 \text{ l/sec (200 gpm)}$$

a) This formula is derived using data from previously presented equations:

(1)	M	=	B + E	from paragraph 4-2.1.1 (19)
(2)	C	=	M ÷ B	from paragraph 4-2.1.2.1 (20)
(3)	C	=	(B + E) ÷ B	from equation (2) and (1) above
(4)	C	=	1 + (E ÷ B)	rearranging equation (3)
(5)	(C - 1)	=	E ÷ B	rearranging equation (4)
(6)	B	=	E ÷ (C - 1)	rearranging equation (5)

b) If you know the quantity of evaporation, you can calculate the blowdown required for a given value of COC. You can estimate the evaporation using simple "rule of thumb" estimates:

b.1) For a typical recirculating cooling tower water system, approximately 1% of the recirculating rate (R) of the cooling water is evaporated for every 5.5 °C (10 °F) temperature drop in the cooling water as it passes through the tower; therefore, you may calculate the evaporation rate (E) this way:

$$\text{EQUATION} \quad | \quad E(\text{l/sec}) = 0.01 \times R(\text{l/sec}) \times \Delta T \text{ drop in } ^\circ\text{C} \div 5.5 \text{ } ^\circ\text{C}$$

Since  $0.01 \div 5.5 = 0.0018$ , this can be condensed to:

$$\text{EQUATION} \quad | \quad E = R \times \Delta T \times 0.0018$$

or

$$\text{EQUATION} \quad | \quad E = R \times \Delta T \div 550$$

NOTE: Newer cooling towers can have 0.75% of the recirculation rate evaporated for every 5.5 °C (10 °F) drop.

**EXAMPLE 2:** A cooling system operates at 315 liters per second (5000 gallons per minute). The temperature drop through the tower is 7.8 oC (14 oF). The evaporation estimate is represented by this equation:

$$\text{EQUATION} \quad | \quad E = 0.01 \times 315 \text{ l/sec (5000 gpm)} \times 7.8 \text{ } ^\circ\text{C (14 } ^\circ\text{F)} \div 5.5 \text{ } ^\circ\text{C (10 } ^\circ\text{F)} = 4.5 \text{ l/sec (70 gpm)}$$

or

$$\text{EQUATION} \quad | \quad E = 315 \times 7.8 \div 550 = 4.5 \text{ l/sec (70 gpm)}$$

For a cooling tower system serving air conditioner and chiller operations, the evaporation rate used depends on the type of chiller:

- Approximately 20 liters per hour per kilowatt (1.5 gallons per hour per ton) for centrifugal, reciprocating, and screw-type chillers.
- Approximately 40 liters per hour per kilowatt (3 gallons per hour per ton) for absorption-type chillers.

**3. OBJECTIVES OF COOLING WATER TREATMENT.** The primary objectives of cooling water treatment are to maintain the operating efficiency of the cooling water system and to protect the equipment that contacts the cooling water. These objectives are accomplished by controlling or minimizing deposition, corrosion, and microbiological growth on the cooling water equipment. Treatment programs must also address requirements for environmental compliance, safety, water conservation, and limitation of chemical costs. This paragraph reviews the requirements for, and elements of, a water treatment program for cooling water systems.

**3.1 DEPOSIT FORMATION AND CONTROL.** Deposits that occur in cooling water systems are usually divided into two categories: scale and fouling. The presence of either type of deposit in the heat exchangers or in the film fill can interfere with heat transfer, thereby reducing the efficiency of operation. Deposits can also promote under-deposit corrosion. Scale and non-biological fouling are described in this paragraph. Biological fouling is described in paragraph 3.4.

**3.2 SCALE.** Scale is formed from minerals, formerly dissolved in water, that were deposited from the water onto heat transfer surfaces or in-flow water lines. As water is evaporated in a cooling tower, the concentration of dissolved solids becomes greater until the solubility of a particular scale-causing mineral salt is exceeded. When this situation occurs in an untreated cooling water system, the scale will form on any surface in contact with the water, especially on heat transfer surfaces. The most common scaling minerals are calcium carbonate, calcium phosphate, calcium sulfate, and silica, usually in that order. Formation of magnesium silicate scale is also possible under certain conditions. Most other salts, including silica, are more soluble in hot water than in cold water; however, most calcium and magnesium salts, including calcium phosphate and calcium carbonate, are more soluble in cold water than in hot water. This is called "reverse solubility." The water temperature will increase as recirculating water passes through the cooling system. As a result, calcium and magnesium scales may form anywhere in the system, but most likely on heated

surfaces such as heat exchangers or surface condensers. Silica will form in areas having the lowest water temperature, such as in the cooling tower fill.

**3.2.1 DETERMINING SCALING POTENTIAL.** The maximum solubility limit for specific dissolved minerals will determine the types of scale that can form under a given set of conditions. To minimize water blowdown, the amount of dissolved materials in the cooling water should be maintained as close as possible to the maximum solubility level. This water quality parameter, TDS, is controlled by maintaining COC in the system at a level that is equal to the lowest COC allowable for whichever salt has the lowest solubility. The salt of concern is often calcium carbonate or calcium phosphate, but it may be silica. The operating COC can be increased substantially with use of the cooling water treatment chemicals described in this paragraph.

**3.2.2 CALCIUM CARBONATE SCALE.** Calcium carbonate scale results from the breakdown of calcium bicarbonate, a naturally occurring salt. The degree of scaling depends primarily on the calcium levels, bicarbonate alkalinity levels, and water temperature in the cooling water system. The most accurate prediction of scale can be developed using the Practical (Puckorius) Scaling Index (PSI) (see paragraph 3.4.2). A rough prediction of calcium carbonate scale potential can be developed using this formula:

$$\text{EQUATION} \quad \left| \quad \equiv \quad \sqrt{\frac{110000}{TA \times M_{ca}}}$$

where

- C = COC
- TA = total (M) alkalinity (as CaCO<sub>3</sub>) in makeup, ppm
- M<sub>ca</sub> = calcium hardness (as CaCO<sub>3</sub>) in makeup, ppm

**3.2.3 CALCIUM PHOSPHATE SCALE.** Calcium phosphate scale results when calcium hardness reacts with phosphate. This will occur when more than 10 ppm of orthophosphate are present in the circulating water and when the calcium hardness is sufficiently high. The following formula can provide a very rough prediction of the potential for calcium phosphate scale:

$$\text{EQUATION} \left| \begin{array}{l} C \\ \equiv \end{array} \right. \frac{(105) \times (9.8 - B_{pH})}{M_{ca}}$$

where

- C = COC, no units
- B<sub>pH</sub> = measured pH in blowdown, pH units
- M<sub>Ca</sub> = calcium hardness (as CaCO<sub>3</sub>) in makeup water, ppm

**3.2.4 CALCIUM SULFATE SCALE.** Calcium sulfate scale results when the calcium hardness reacts with the sulfate. The potential for calcium sulfate scale can be predicted using this formula:

$$\text{EQUATION} \left\{ \begin{array}{l} C \\ \equiv \end{array} \right. \sqrt{\frac{1250000}{M_{ca} \times M_{su}}}$$

where

- C = COC, no units
- M<sub>Ca</sub> = calcium hardness (as CaCO<sub>3</sub>) in makeup, ppm
- M<sub>Su</sub> = sulfate (as SO<sub>4</sub>) in makeup, ppm

**3.2.5 SILICA SCALE.** Silica scale can occur when the concentration of silica exceeds its maximum solubility limit in water. A safe, very conservative value to assume for the solubility limit is 150 ppm (as SiO<sub>2</sub>); thus, the maximum COC can be calculated with this formula. However, silica solubility depends on pH and temperature and is in the

range of approximately 150 to 180 ppm (as SiO<sub>2</sub>) at the temperature range encountered in most cooling towers (26 °C to 54 °C [80 °F to 130 °F]). As the pH increases in the cooling tower water, silica becomes more soluble; thus, if cooling tower water pH is 9.0, approximately 250 ppm silica (as SiO<sub>2</sub>) is the maximum. Using 150 ppm as the upper limit, the allowable COC is represented by this equation:

$$\text{EQUATION} \quad \left| \quad \equiv \quad \frac{150}{M_{si}} \right.$$

where

$$\begin{aligned} C &= \text{COC, no units} \\ 150 &= \text{assumed maximum solubility of silica, ppm} \\ M_{si} &= \text{silica (as SiO}_2\text{) in the makeup, ppm} \end{aligned}$$

**3.3 DETERMINING COC TO CONTROL OPERATIONS.** In cooling water systems, the lowest calculated COC allowable, as determined by the relationships for these salts, is the controlling factor for operations. This is because as the system operates, the material that has the lowest calculated COC will be the first to come out of solution (precipitate) and the most likely to form a scale deposit in the system. To prevent these materials from forming a deposit on cooling water equipment, you must keep the COC in the system at a level that is lower than the lowest COC calculated for calcium carbonate, calcium phosphate, calcium sulfate, and silica. Using appropriate water treatment chemicals will allow higher COC, depending on which chemical is used.

**EXAMPLE 3:**



a) A cooling tower makeup has the following composition:

Calcium hardness	100 ppm as CaCO <sub>3</sub>
Total (M) alkalinity	60 ppm as CaCO <sub>3</sub>
Phosphate	3 ppm as PO <sub>4</sub>
Sulfate	60 ppm as SO <sub>4</sub>
Silica	14 ppm as SiO <sub>2</sub>
pH	7.2

At what COC can the system operate scale free without water treatment? (Assume that the estimated pH in the blowdown water is 8.5.)

b) Based on calcium carbonate:

$$\text{EQUATION} \quad \left| \quad \equiv \sqrt{\frac{110000}{60 \times 100}} \equiv 4.3$$

c) Based on calcium sulfate:

$$\text{EQUATION} \quad \left| \quad \equiv \sqrt{\frac{1250000}{100 \times 60}} \equiv 14.4$$

d) Based on silica:

$$\text{EQUATION} \quad \left| \quad \text{COC} \quad \equiv \quad 150 \div 14 = 10.7$$

The COC determined for calcium carbonate is lowest at 4.3, and this controls the system operation. If the system is operated without water treatment, scaling should not occur if the system is operated at less than 4.3 COC. Use of scale control treatment will allow the number of allowable COC (for calcium carbonate) to be increased; you can then determine the COC and blowdown by using a calculated scaling index.

**3.4 CALCIUM CARBONATE SCALING INDICES.** The scale found most commonly in cooling tower water systems is calcium carbonate, present in the form of calcite ( $\text{CaCO}_3$ ) (i.e., limestone). The solubility of calcium carbonate, which decreases with an increase in temperature, is a complex function of temperature, TDS, calcium hardness, total alkalinity, and pH. To predict if scale would form in the hotter sections of a cooling water system, researchers have developed several scaling indices. Paragraphs 3.4.1 and 3.4.2 describe the predictive indexes that are used most commonly for cooling water.

**3.4.1 LANGELIER AND RYZNAR INDICES.** W.F. Langelier derived a method to calculate the calcium carbonate scale-forming and scale-dissolving tendencies of drinking water. The method is based on determining the saturation pH ( $\text{pH}_s$ ) at which calcium carbonate scale will start to precipitate out of solution. If the measured pH ( $\text{pH}_{\text{actual}}$ ) of the water is greater than its  $\text{pH}_s$ , thus a positive value, the water has a scale-forming tendency. If the measured pH ( $\text{pH}_{\text{actual}}$ ) of the water is less than its  $\text{pH}_s$ , thus a negative value, the water will have a scale-dissolving tendency. The  $\text{pH}_{\text{actual}}$  minus  $\text{pH}_s$  is known as the Langelier Index or Langelier Saturation Index (LSI) ( $\text{LSI} = \text{pH}_{\text{actual}} - \text{pH}_s$ ). This index was originally designed to predict calcium carbonate scale in potable water. There are serious deficiencies in the accuracy of this index; consequently, it has lost its practical application for cooling water systems. J.W. Ryznar later devised a more sensitive formula for predicting calcium carbonate scale. This formula is known as the Ryznar Index or Ryznar Stability Index (RSI). The formula is:  $2\text{pH}_s - \text{pH}_{\text{actual}}$ . A value of 6 indicates “stable” water, a value less than 6 indicates a scale-forming tendency, and a value greater than 6 indicates a scale-dissolving tendency. The indices have also been used to try to estimate the degree to which calcium carbonate scale will form in drinking water and in cooling water. The more positive the LSI value, the greater the scale formation; however, for the RSI, the smaller the index, the greater the scale formation. The LSI and RSI can give conflicting predictions based on the same water quality information.

**3.4.2 PRACTICAL (PUCKORIUS) SCALING INDEX (PSI).** Paul R. Puckorius and J. Maxey Brooke developed a modified version of the RSI that gives a more accurate and consistent indication of the calcium carbonate scaling potential of cooling water. Known as the Practical Scaling Index (PSI), and also known as the Puckorius Scaling Index, it takes into consideration the effect of the type of total alkalinity of the cooling water on the measured pH (pH<sub>actual</sub>) value. The measured pH does not always relate correctly to bicarbonate alkalinity because of the buffering effect of other ions. Rather than using the measured pH in calculating the PSI, an adjusted or equilibrium pH (pH<sub>eq</sub>) is used:  $PSI = 2pH_s - pH_{eq}$ . As with the RSI, a PSI value of 6 indicates stable water and a value lower than 6 indicates a scale-forming tendency. Without scale-control treatment, a cooling tower with a PSI of 6 to 7 should operate scale free. However, a PSI of greater than 6 indicates that scaling may occur. Information on calculating the PSI is provided in Appendix B. Use of the PSI is most applicable when cooling water pH is above 7.5.

**3.5 SCALE-CONTROL METHODS.** Three basic methods are used to prevent the formation of scale in cooling water systems:

- a) Remove the water scaling ingredients from the water before use. This includes softening, RO, and other technologies.
  
- b) Keep the scale-forming ingredients in solution. This is the most common scale-control method used for cooling water, and it can be achieved by use of either or both of the following two methods: adding acid, which lowers the pH of the recirculating water, or adding a scale inhibitor (phosphonate or specific polymer), which allows higher COC to be maintained without scaling. Acid neutralizes (destroys) mineral alkalinity, one of the constituents forming calcium carbonate scale; however, because of the hazards associated with handling strong acids and the potential damage from an acid spill, the use of acid in cooling towers is not recommended.

c) Allow the water-scaling ingredient to precipitate as sludge. Modern chemical treatment can distort or modify scale crystals such that they cannot adhere to each other to form a hard deposit; instead, they become a sludge that can be removed through filtration or blowdown.

All three methods are authorized for use on military installations and can be used in combination with one another.

### **3.5.1 CALCIUM CARBONATE SCALE CONTROL USING SOLUBILIZING**

**CHEMICALS.** Acids and phosphonates are chemicals that keep scale from forming. The use of acid in cooling towers may not be appropriate for use at military installations due to the associated risk of corrosion.

**3.5.1.1 ACIDS.** The acid most commonly used is sulfuric acid used as a diluted solution (e.g., 40% sulfuric acid in water). The use of acids requires adequate pH control.

**3.5.1.2 PHOSPHONATES.** The phosphonates used most frequently for calcium carbonate scale control in recirculating cooling water systems are AMP (amino-tri [methylene] phosphonic acid); HEDP (1-hydroxyethylidene 1,1-diphosphonic acid); and PBTC (2-phosphonobutane-1,2,4-tricarboxylic acid). The chemical reaction of all phosphonates is similar; however, their stability varies greatly. The presence of chlorine or other oxidants in treated cooling water favors the use of PBTC, which is very resistant to decomposition, followed by HEDP, and finally AMP. An active dosage of 3 to 5 ppm of either AMP or HEDP, or 1.5 to 2.5 ppm PBTC, will increase the solubility of calcium carbonate by a factor of 3 or more relative to using no chemical treatment. Rather than operating at a PSI of 6.0 (stable water, no scale) in an untreated system, the cooling tower water can be used at a PSI of 4.0 without the occurrence of scale (see paragraph 3.4.2); however, in the absence of calcium scaling conditions, phosphonates can increase the corrosion of both mild steel and copper.

### **3.5.2 CALCIUM CARBONATE SCALE CONTROL USING SOLUBILIZING**

**POLYMERS.** Many different polymers are used in water treatment. For the most part, they have multi-faceted performance capability; they can inhibit various types of scale formation as well as disperse SS. Often water treatment products will include more than one type of polymer in the product formulation. For control of calcium carbonate, homopolymers such as polyacrylate, polymethacrylate, and polymaleate are used to keep calcium carbonate in solution. Dosages of 3 to 5 ppm of active polymer in the cooling tower water can control calcium carbonate scale formation to a PSI value as low as 4.5.

### **3.5.3 CALCIUM CARBONATE SCALE CONTROL USING SLUDGE-FORMING**

**POLYMERS.** Certain homopolymers and copolymers act as crystal modifiers by distorting calcium carbonate crystals such that they do not attach themselves to heat exchange surfaces, but instead the crystals become SS that can be removed through filtration or blowdown. Usually dosages of 1 to 3 ppm of active polymer in the cooling tower water will control calcium carbonate scale. Due to formation of sludge, rather than the stabilization of carbonate in solution, the PSI is not meaningful under these conditions.

### **3.5.4 CALCIUM PHOSPHATE SCALE CONTROL USING SOLUBILIZING**

**INHIBITORS.** Often calcium phosphate scale is formed in cooling water systems treated with a phosphate-based corrosion inhibitor program or when phosphate is present in the makeup water (i.e., potable or recycled water). Calcium phosphate is much less soluble in water than is calcium carbonate. If the calcium hardness is 500 ppm and the pH is above 7.0, without any polymer treatment calcium phosphate scale will likely form, even at the low level of 10 ppm phosphate (as PO<sub>4</sub>) in the cooling water (see paragraph 3.3). Calcium phosphate solubility can be increased by a factor of a little less than 3 by the addition of 4-ppm phosphonate (HEDP/PBTC) or by the use of 6 to 8 ppm of a copolymer or terpolymer specific for calcium phosphate inhibition.

### **3.5.5 CALCIUM SULFATE SCALE CONTROL USING SOLUBILIZING POLYMERS.**

Calcium sulfate formation can result from high concentrations of calcium ions and sulfate ions in the recirculating water; however, calcium sulfate is the most soluble of the scale-forming calcium salts found in cooling tower waters having pH levels of greater than 8.0. This means that calcium sulfate scale will not form unless some calcium ions (hardness) remain in solution after the calcium reacts with all the carbonate and phosphate in the water. Calcium sulfate scale may occur when the recirculating water contains calcium hardness in the range of 500 to 700 ppm as CaCO<sub>3</sub> and sulfate in the range of 500 to 700 ppm SO<sub>4</sub>. (See the predictive index in paragraph 3.4) The addition of 3 to 5 ppm of a copolymer of acrylate and acrylamide will allow calcium sulfate to remain in solution at a level almost 3 times the level allowed when using no treatment. Calcium sulfate scale rarely forms at pH levels above 8.0 in the cooling water.

**3.5.6 MAGNESIUM SILICATE SCALE CONTROL.** Formation of magnesium silicate is possible in cooling systems, but only under certain rare conditions. Magnesium ions (hardness) first react with hydroxyl ions (OH<sup>-</sup>) to form magnesium hydroxide, which then reacts with (absorbs) dissolved or colloidal silica. A deposit analysis often reports this material as magnesium silicate. Since magnesium hydroxide solubility decreases at pH levels above 9.0, this scale will usually occur only at a pH level above 9.0 and when the magnesium hardness concentration is greater than 100 ppm.

**3.5.7 SILICA SCALE CONTROL.** Silica solubility is dependent upon temperature and pH. At pH levels greater than 8.5, silica remains soluble (no scale) at a concentration of 250 ppm as SiO<sub>2</sub>. At pH levels of 7.5 or below, maximum silica solubility is 150 ppm as SiO<sub>2</sub>. At maximum silica levels, silica will first deposit on the cooling tower slats rather than in the heat exchanger because silica is more soluble in hot water than in cold water. The slats will become coated with a white, sometimes sparkling, deposit. If this occurs, blowdown should be increased to decrease COC by at least 1 unit. This procedure should stop additional scale formation. If the concentration of silica in the makeup water is above 30 ppm, it will usually be the parameter that controls the

adjustment of cooling water system COC. If the silica concentration is high, external treatment can reduce the level of silica in the makeup water. The introduction of water treatment chemicals based on new polymer technology may allow the solubility of silica to be increased above the old recognized limit of 150 ppm.

Scale	Control Method
Calcium carbonate	1. Solubilize using phosphonates. 2. Solubilize using polymers (polyacrylate, polymethacrylate, polymaleate). 3. Form sludge using specialty polymers.
Calcium phosphate	1. Solubilize using phosphonates. 2. Solubilize using specialty copolymers or terpolymers.
Calcium sulfate	Solubilize using copolymers of acrylate and acrylamide.
Magnesium silicate	Maintain water chemistry of: pH < 9.0, magnesium hardness < 500 ppm, and silica < 100 ppm.
Silica	1. Maintain water chemistry with silica < 150 ppm. 2. Solubilize with silica-specific polymer.

Table 1  
Summary of Scale Control Methods

**3.6 COOLING WATER FOULING.** The term “fouling” refers to the deposition of materials that are normally held in suspension in the cooling water: mud, silt, and other SS brought into the system with the makeup water; dust, dirt, and debris scrubbed out of the air passing through the tower; product leakage such as oils; corrosion products from the system; and biological organisms, both living and dead. Combinations of any or all of these materials can be present in the cooling water.

**3.7 FOULING CONTROL.** Fouling from mud, dirt, and corrosion products can be controlled by the addition of a water-soluble polymer dispersant, such as a polyacrylate. The addition of about 4 to 5 ppm of active polymer, together with sufficient water velocity (e.g., 1 meter per second [3.28 feet per second]), can keep foulants in suspension and prevent them from being deposited on heat transfer

surfaces. Higher dosages (5 to 20 ppm) of active polymer can be required for heavily fouled systems. It is best to reduce the loading of SS by mechanically removing them from the system through blowdown, filtration, and physical sump cleaning. Removing oil or oily materials requires a non-foaming surfactant. Paragraph 4 describes prevention of fouling by biological organisms. Table 2 summarizes foulant control methods.

<b>Foulant</b>	<b>Control Method</b>
Mud, dirt, corrosion products	1. Disperse using polymers and maintain adequate flow. 2. Form sludge using specialty polymers.
Oily matter	Disperse using a non-foaming surfactant.

Table 2  
Summary of Foulant Control Methods



**4. MICROBIOLOGICAL DEPOSITS AND CONTROL.** Microbiological organisms are composed of three classes: algae, bacteria, and fungus. Large biological organisms such as clams, snails, mussels, or similar species are referred to as macrobiological organisms. The presence of any biological growth can be detrimental to cooling tower operations. Problems include fouling, corrosion, and loss of efficiency. These problems can lead to downtime, higher operating cost, and even premature replacement of equipment. Additionally, some bacteria are pathogenic and can pose a risk to human life.

**4.1 ALGAE.** The term “algae” refers to algal, microbiological, tiny, stringy blue and blue-green plants, which are usually found growing in masses on top of and on sides of cooling towers. Algae grow only in sunlit areas. They will slough off and become part of the suspended matter in the circulating water, a situation which may cause fouling and plugging of water sprays. Algae also provide a breeding place, and are a nutrient, for bacteria.

**4.2 BACTERIA.** The term “bacteria” refers to a large group of one-celled microorganisms. Bacteria can grow in either the absence or presence of sunlight. There are several ways to classify bacteria, including “aerobic,” meaning those living in the presence of oxygen, and “anaerobic,” meaning those living in the absence of oxygen. In a cooling water system, one can categorize bacteria as either “planktonic” or “sessile,” which are terms that describe whether the bacteria are, respectively, either free floating or found growing on surfaces (stickers). Categories of bacteria are described below. 3 shows types of bacteria and their growth conditions.

**4.2.1 PLANKTONIC BACTERIA.** Planktonic bacteria are suspended in the water, sometimes referred to as “free floaters” or “swimmers,” and are aerobic bacteria that thrive in an oxygenated environment. They are not harmful to the cooling system since they do not cause deposits or corrosion, but they can provide nutrients for other

microorganisms; in addition, some planktonic bacteria such as Legionella Pneumophila are pathogenic and can present a significant human health risk.

**4.2.2 SESSILE BACTERIA.** Sessile bacteria are stickers, or non-swimming bacteria, and can cause deposits and corrosion. Sessile bacteria types include slime-formers and anaerobic (corrosive) bacteria. Slime-formers can grow and form gelatinous deposits on almost any surface in contact with the cooling water. These deposits can grow so large that they restrict water flow and interfere with heat transfer; they also may promote under-deposit corrosion. Feeling the sides of the cooling tower basin just below the water level is one way to detect the presence of slime-formers. Usually if there are slime formers in the system, you can feel deposits. Anaerobic bacteria thrive in oxygen-deprived environments and often establish colonies beneath slime deposits or under other types of deposits. One type of anaerobe is sulfate-reducing bacteria (SRB), which produce hydrogen sulfide, a chemical that is very corrosive to metals. This type of corrosion attack is very localized and can result in pipe and tube failures. The presence of SRB should be suspected in a water system if the underside of a slime layer is black or if you detect the odor of rotten eggs. Any type of microbiological corrosion is referred to as microbiologically influenced corrosion (MIC). Bacteria cause most of the MIC found in cooling water systems. Use surface microbiological measurements to monitor sessile bacteria.

Bacteria Type	Technical Names and Examples	Conditions for Growth		Problems Created
		Temperature	pH	
Aerobic - capsulated	<ul style="list-style-type: none"> <li>• Aerobacter aerogenes</li> <li>• Flavobacterium</li> <li>• Proteus vulgaris</li> <li>• Pseudomonas aeruginosa</li> <li>• Serratia</li> <li>• Alcaligenes</li> </ul>	20-40 °C (68-104 °F)	4-8 (7.4 optimum)	Severe bacterial slimes are formed; these are gelatinous deposits
Aerobic - spore forming	<ul style="list-style-type: none"> <li>• Bacillus myocoides</li> <li>• Bacillus subtilis</li> </ul>	20-40 °C (68-104 °F)	5-8	Bacterial slimes; spores produced are difficult to destroy
Aerobic -sulfur	<ul style="list-style-type: none"> <li>• Thiobacillus thiooxidans</li> </ul>	20-40 °C (68-104 °F)	0.6-6	Sulfur or sulfides are oxidized to sulfuric acid
Anaerobic –sulfate reducing	<ul style="list-style-type: none"> <li>• Desulfovibrio desulfuricans</li> <li>• Clostridium</li> </ul>	20-40 °C (68-104 °F)	4-8	Grows under deposits causing corrosion; converts sulfates to hydrogen sulfide (rotten egg smell)
Iron depositing	<ul style="list-style-type: none"> <li>• Crenothrix</li> <li>• Leptothrix</li> <li>• Gallionella</li> </ul>	20-40 °C (68-104 °F)	7.4-9.5	Converts soluble iron salts to iron oxide; can form voluminous deposits

Table 3

## Bacterial types and problems created

**4.3 FUNGI.** The term “fungi” refers to classes of organisms made up of molds and yeasts, some of which attack and cause wood decay in cooling towers. The control of fungi requires special preservative treatment of wood. Fungi also produce deposits in cooling water equipment.

**4.4 MICROBIOLOGICAL CONTROL.** The term “microbiological control” refers to techniques used to minimize the presence of microbiological organisms in cooling water. Chemical biocide treatment is the method used on government installations for microbiological control in cooling water. Biocides that are used to control microbiological growth fall into one of two broad categories: oxidizing and non-oxidizing microbiocides. A cost-effective approach for control involves the regular use of oxidizers as a primary biocide, augmented by selective use of non-oxidizing biocides. Important factors for the effectiveness of any biocide include using a proper dosage and allowing adequate contact time with the microbiological organisms. All microbiocides are toxic and must be handled safely and with caution; use the MSDS for safety instructions.

**4.4.1 OXIDIZING BIOCIDES.** “Oxidizing biocides” is a term describing microbiocides that oxidize or irreversibly “burn up” the bio-organisms. Oxidizing biocides also destroy nutrients that the microorganisms require for growth. Avoid addition of excess amounts (over-feeding) of oxidizing biocides because they are corrosive to metal and wood in the cooling system and have the potential to destroy some scale and corrosion inhibitors. The various oxidizing biocides are described below. 6 provides guidelines for selecting oxidizing microbiocides.

**4.4.1.1 CHLORINE AND CHLORINE RELEASE AGENTS.** Chlorine (Cl<sub>2</sub>) compounds are the most effective industrial oxidizing biocides and the most widely used. Chlorine is available as a chlorine gas, dry calcium hypochlorite (HTH), liquid sodium hypochlorite (bleach), plus several other dry products that release chlorine. When chlorine is introduced into water, it hydrolyzes to form hypochlorite ion (OCl<sup>-</sup>) and

hypochlorous acid (HOCl); it is the latter chemical that is the stronger oxidizing biocide. The presence of hypochlorous acid is greater, proportionate to hypochlorite ion, at low pH levels. At a pH of 5.0, hypochlorous acid exists almost exclusively. At a pH of 7.5, there are approximately equal amounts of hypochlorous acid and hypochlorite ion. Figure 16 shows this relationship. Chlorine is effective, but to a lesser degree, as a biocide at a pH of 7.5 or greater because the hypochlorite ion has about one-tenth the biocidal efficacy of hypochlorous acid. A pH range of 6.5 to 7.5 is considered optimal for chlorine or chlorine-based microbiological control programs. Above pH 7.5, relatively higher levels of chlorine are required to be effective. Military installations seldom use gaseous chlorine for treating cooling towers because of safety concerns, difficulty with controlling the feed of the gas, and increasing concern for the environmental effects of escaping residual chlorine gas. The most commonly used chlorine-based products are bleach and HTH.

<b>Release Agents</b>	<b>Comments</b>
Sodium hypochlorite 12%	Concentrated liquid bleach
Calcium hypochlorite (HTH)	Dry product; releases chlorine
Chlorine gas	Gaseous chlorine
Chloroisocyanurates	Dry organic chlorine compound; releases chlorine and cyanuric acid

Table 4  
Chlorine release agents

$\text{HOCl}$  = hypochlorous acid  
 $\text{OCl}^-$  = hypochlorite ion  
 $\text{HOBr}$  = hypobromous acid  
 $\text{OBr}^-$  = hypobromite ion  
 $\text{Cl}_2$  = chlorine  
 $\text{Br}_2$  = bromine

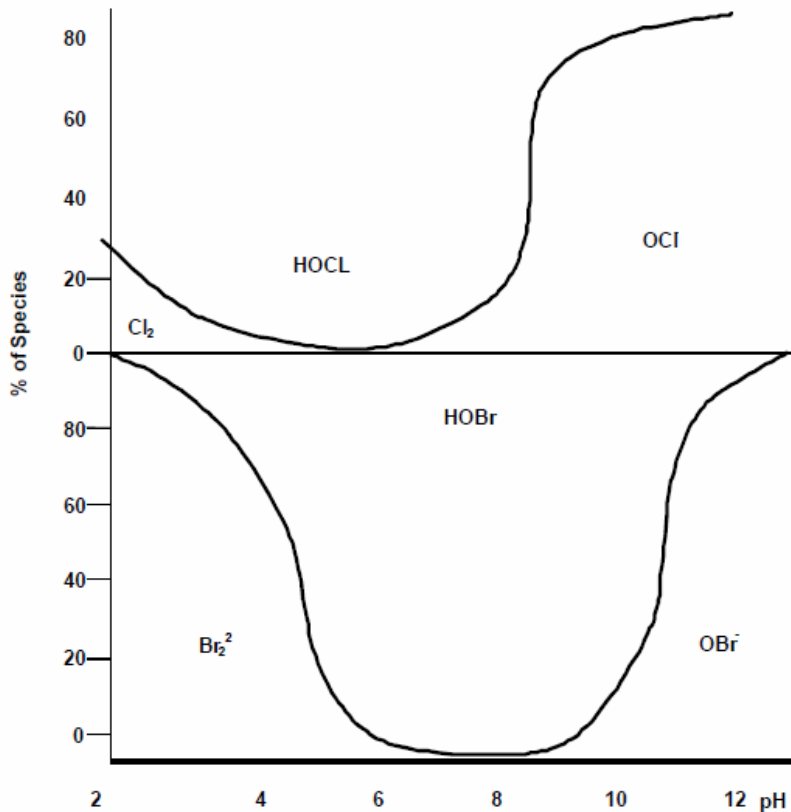

Figure 16

Halogen species vs. pH in water

4.4.1.2 Bromine Release Agents. Bromine ( $\text{Br}_2$ ) compounds are very similar to chlorine compounds. Although more expensive than chlorine compounds, their main advantage is that bromine is more effective at higher pH ranges (7.5 or greater) than chlorine. Bromine has a lower vapor pressure than chlorine and is 6 times as soluble in water, making it less subject to vaporization loss from a cooling tower. When bromine is introduced to water, it hydrolyzes to form hypobromite ion ( $\text{OBr}^-$ ) and hypobromous acid ( $\text{HOBr}$ ); Figure 16 shows this relationship. A pH range of 7.5 to 10.0 is considered optimal for the use of bromine. Bromine release agents include dry chemicals called hydantoin and bromine salts, such as sodium bromide. When a salt solution is mixed with an oxidizing agent, such as bleach, and a reaction occurs, bromine is produced. In water, bromine degrades more rapidly than chlorine. Recent

developments in bromine chemistry have resulted in the production of a bromine solution (liquid). Table 5 shows examples of some bromine release agents. The most popular sources of bromine are the dry bromine release products.

Release Agent	Comments
Bromo-chloro-dimethyl hydantoin	Dry product – releases bromine
Bromo-chloro-methyl-ethyl hydantoin	Dry product – releases bromine
Isocyanuric acid plus sodium bromide	Dry product – releases bromine
Chlorine plus sodium bromide	Produces bromine liquid
Peroxide plus sodium bromide	Produces bromine liquid
Ozone plus sodium bromide	Produces bromine liquid
Stabilized bromine	Hydrobromite liquid

Table 5  
Bromine Release Agents

**4.4.1.3 OZONE.** Ozone (O<sub>3</sub>) is a gas produced by passing dry air either through a strong electric field or near an ultraviolet light. If ozone is dissolved in water, the resulting solution can be added to cooling water. Ozone is a very strong oxidizing biocide that, if properly applied, can provide effective control of microorganisms in cooling tower systems; however, because of safety and operational problems associated with its manufacture and use, and the resulting high capital and operating costs, it is neither the most economical method nor the preferred method for microbiological control in cooling towers under normal operations. Ozone can increase metal corrosion and does not prevent scale.

**4.4.1.4 CHLORINE DIOXIDE.** Chlorine dioxide (ClO<sub>2</sub>) is a gas generated by mixing several chemicals. The chlorine dioxide gas produced in this manner is subsequently dissolved in water, with the water containing the chlorine dioxide then added to the cooling water. Chlorine dioxide must be produced in close proximity to the point of use.

It is not recommended for use on some installations due to the complexity of its production and safety concerns associated with its production and handling.

**4.4.1.5 HYDROGEN PEROXIDE.** Hydrogen peroxide (H<sub>2</sub>O<sub>2</sub>) is a liquid that is usually used at a concentration of 30% in water. Hydrogen peroxide is considered one of the most environmentally friendly oxidizing biocides because it degrades to water; however, concentrated hydrogen peroxide will react in a violent manner when it comes into contact with organic chemicals and materials.

**4.4.2 NON-OXIDIZING BIOCIDES.** Non-oxidizing biocides are microbiocides that act as “poisons;” they disrupt the metabolic or reproductive processes of micro- and macro-organisms and are therefore toxic. Non-oxidizing biocides are organic compounds that are very toxic to organisms, including human beings and animals. They are usually liquids, but some are available as dry products (e.g., pellets, solids). A major consideration for their use is their persistence with respect to the discharge limitations for water (effluent) containing these toxic substances. Also, when choosing and applying a non-oxidizing biocide, you must consider the cooling tower system’s operating parameters, such as pH and retention time. The applied dosages of microbiocides should never exceed EPA maximum limits, which are always printed on the container labels. The labels will also identify the active microbiocide ingredient, the percentage of each chemical that is present in the formulation, and the EPA registration number. Control programs often combine both oxidizing and non-oxidizing biocides. The most important aspect of bio-fouling control is to match the non-oxidizing biocide to the problem organism. Table 7 provides guidelines for non-oxidizing biocide effectiveness.



Microbiocide	Bacteria Types					Fungi	Algae	Comments
	Slime Forming		Iron Depositing	Corrosive				
	Spore Formers	Non-spore Formers						
Chlorine	P	E	E	N		P	F	Dangerous to handle; corrosive to metal; available as dry, gas, or liquid; less effective higher pH (> 7.5)
Bromine	F	E	E	N		P	F	Can be produced from bromides; very effective at pH 6.0-10.0; very effective with ammonia; less volatile than chlorine
Ozone	E	E	E	F		G	P	Very volatile; can attack wood, PVC, copper, and gaskets
Chlorine dioxide	G	E	E	N		P	F	Must be produced onsite; very volatile; not sensitive to pH; does not react with ammonia and many organics
Peroxide	G	G	G	F		P	F	Does not add TDS; degrades to water

E = Excellent G = Good F = Fair P = Poor N = Not effective

Table 6

Guidelines for oxidizing microbiocide effectiveness

Microbiocide	Bacteria					Fungi	Algae	Comments
	Slime Forming		Iron Depositing	Corrosive				
	Spore Formers	Non-Spore Formers						
Quaternary ammonium salts	E	E	E	G		P	G	Effective pH 6.5-9.2; foaming potential; reacts with anionics
Organo tin plus quaternaries	E	E	E	G		P	G	Effective pH 6.5-9.2; foaming potential; reacts with anionics; tin compounds often restricted
Dibromo-nitrilo-propionamide	E	E	E	G		N	P	Effective pH 6.5-7.5; degrades quickly; uses glycol solvent
Methylene bis thiocynate	E	E	G	E		P	P	Effective pH < 7.5; deactivated with high pH
Isothiazolone	E	E	G	G		G	G	Effective pH 4.5-9.3; dangerous to humans
Dodecylguanidine	E	E	G	G		G	G	Effective pH 6.5-9.5
Glutaraldehyde	E	E	G	E		G	G	Effective pH 6-10
Terbutylazine	N	N	N	N		N	E	Very effective algaecide; blocks photosynthesis
Carbamates	E	E	G	G		G	F	Eff. pH 7-9; corrodes copper

E = Excellent G = Good F = Fair P = Poor N = Not effective

Table 7

Guidelines for non-oxidizing microbiocide selection



**4.5 ALGAE CONTROL.** Algae can be controlled by two techniques: chemical methods and physical methods. Since algae require sunlight to survive and grow, covering the upper hot water decks of cooling towers with plywood can often control algae deposits. Chemical methods consist of using oxidizing and non-oxidizing biocides, which can control algae to various degrees (see Tables 6 and 7). The effectiveness of oxidizers is considered only fair while that of several non-oxidizers is in the range of very good to excellent. One of the more effective biocides for algae is terbutylazine, a triazine product (see 7).

**4.6 BACTERIAL CONTROL.** Accepted industry practice for bacterial control is the use of oxidizing and non-oxidizing biocides that are specific for the type of bacteria. The most cost-effective microbiocide programs for medium and large cooling towers use an oxidizer as a primary biocide and one or more non-oxidizers selectively as a secondary biocide (see Tables 6 and 7). Smaller cooling systems often use one or more non-oxidizing biocides, although dry oxidizing biocides are also used commonly. The most overlooked aspect of bacterial control is maintaining a system kept clean of deposits and SS (i.e., dirt, silt, sand, corrosion products) through the use of filters and periodic wash-down procedures. Clean systems reduce the demand for chemical and microbiological control. Table 8 shows accepted industry guidelines for a bacterial control program with the use of a test kit.

Bacterium Type	Colony-Forming Units/ml
Total aerobic bacteria	< 10 <sup>4</sup>
Sulfate-reducing bacteria	Undetectable
Surface microbiological	< 10 <sup>6</sup> – Undetectable

Table 8  
Guidelines for bacterial control in cooling towers

**4.6.1 BACTERIAL CONTROL WITH OXIDIZING BIOCIDES.** Bacterial control with oxidizing biocides can be accomplished by either continuous feed or slug feed of the

oxidant. A continuous-feed process typically maintains 0.1 to 0.3 ppm of free halogen in the return water to the cooling tower. A typical slug-feed process adds treatment chemicals periodically to give 0.5 to 1.0 ppm of free halogen in the return water to the cooling tower for a period of 2 to 4 hours, 3 times per week. Halogen refers to the group of elements including chlorine and bromine. "Free" halogen refers to the measured residual of halogen available for disinfection. Stabilized Halogen technology is generally controlled on a total halogen residual. For continuous feed, control at 0.5 to 1 ppm total, and for slug feed control at 2.4 ppm for a period 2-4 hours, 3 times per week.

**4.6.2 BACTERIAL CONTROL WITH NON-OXIDIZING BIOCIDES.** Bacterial control with non-oxidizing biocides uses one or more biocides as shown in 7. Usually different non-oxidizers are added on an alternating schedule; they are slug-fed every other week for optimum effectiveness. Each time you use a non-oxidizing biocide, it is important to maintain an adequate dosage for 24 hours to enable sufficient contact time for maximum effectiveness.

**4.7 LEGIONNAIRES' DISEASE.** Legionnaires' Disease (Legionellosis) is a respiratory disease (atypical pneumonia) that is caused by infection of susceptible individuals who have inhaled a fine water mist containing the bacterium known as Legionella Pneumophila. Water in a cooling tower can become infected with the bacterium if an inadequate microbiological control situation occurs. The presence and density of Legionella Pneumophila bacteria cannot be detected by standard microbiological testing methodologies. Instead, cooling water samples must be sent to a laboratory that has been certified to conduct the required tests. If the presence of the bacteria in cooling water is established, proper disinfection steps are required. A procedure known as the Wisconsin Protocol, developed by the Wisconsin State Health Department, has proven effective. This protocol requires the addition of high dosages of chlorine (10 ppm free residual) at a pH of less than 7.5 for 24 hours, flushing the system, then repeating. Additional testing for Legionella is required to determine the effectiveness of the procedure. Maintaining a clean, microbiologically free cooling

water system and using effective water treatment is preferable to dealing with remedial efforts. The Cooling Technology Institute (CTI) and the American Society of Heating, Refrigerating, and Air Conditioning Engineers (ASHRAE) have published position papers on the prevention of Legionella; these can be downloaded from their respective websites: <http://www.cti.org/> and <http://www.ashrae.org/>.

**4.8 MACROBIOLOGICAL CONTROL.** The term “macrobiological control” refers to control of larger biological organisms such as mussels, clams, and snails. They can exist in cooling systems that use seawater or river water as makeup. The first line of defense is using mechanical prevention with strainers and filters on the intake water to prevent infiltration into the cooling water system. Control methods within the cooling system include thermal shock and chemical treatment with oxidizing and non-oxidizing biocides.

**5. CORROSION IN COOLING SYSTEMS.** The term “corrosion” (in a cooling water system) is defined as the electrochemical deterioration of a metal that is in contact with cooling water. Corrosion occurs when an electric current flows from one part of the metal (anode) through the water (electrolyte) to another part of the metal (cathode). Corrosion takes place at the anode only. The cathode is the driving force of the corrosion action. Forms of corrosion associated with industrial water systems are illustrated in Figure 17.

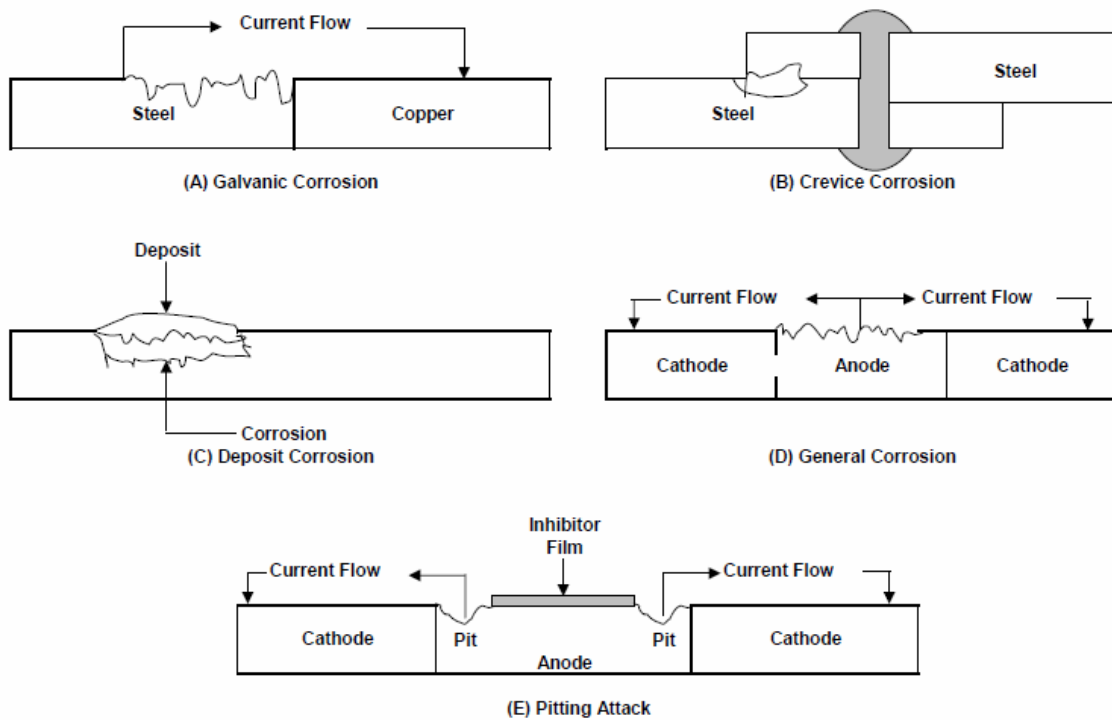

Figure 17  
Forms of corrosion

**5.1 GALVANIC CORROSION.** See Figure 17 (A). This term refers to corrosion that occurs when two different metals are coupled together. The metal with the least resistance becomes the anode and will corrode due to the electrochemical reaction produced. One of the most common instances of galvanic corrosion occurring in cooling water systems results when mild steel and copper alloy metals are brought into

contact with one another (e.g., copper tubing attached to a mild steel tube sheet or brass valves connected to mild steel or galvanized piping). As a result of the electrochemical reaction, the copper is dissolved in the water and corrosion of copper alloy results. The copper can also plate out (stick) on mild steel surfaces, setting up additional galvanic cells. Another example is the electrochemical reaction that occurs when mild steel and zinc (galvanizing) are coupled together at temperatures normally found in cooling tower systems. The zinc becomes the anode and is corroded. Figure 18 shows the galvanic series. Any coupling of a metal that is higher in the galvanic series with a metal or alloy that is lower in the galvanic series results in electrochemical reaction in which the “higher” metal functions as the anode or active metal.

**5.2 GENERAL CORROSION.** See Figure 17 (D). The term “general corrosion” refers to uniform corrosion of metal surfaces. A single piece of metal will have cathodic and anodic areas due to differences in impurities and stresses. These areas will change periodically, causing the metal to corrode over the entire surface at a more or less uniform rate.

**5.3 CONCENTRATION CELL CORROSION.** When two pieces of the same metal are in a solution capable of acting as an electrolyte, and the electrolyte contains different substances or the same substance in different amounts, such as a salt or a mixture of salts, or oxygen, an electrical potential difference will develop between them.

**5.3.1 CREVICE CORROSION.** See Figure 17 (B). The term “crevice corrosion” refers to corrosion that occurs in a slight separation between two pieces of metal, such as at the contact point of two mild or stainless steel plates that have been bolted together. Water flow is restricted in a crevice and, as a result, oxygen is consumed faster than it can be replenished. The metal in the crevice functions as an anode and corrodes. This is a form of concentration cell corrosion, also called “differential oxygen cell” corrosion. Stainless steel is particularly susceptible to this type of corrosion, which results in localized or pitting attack.



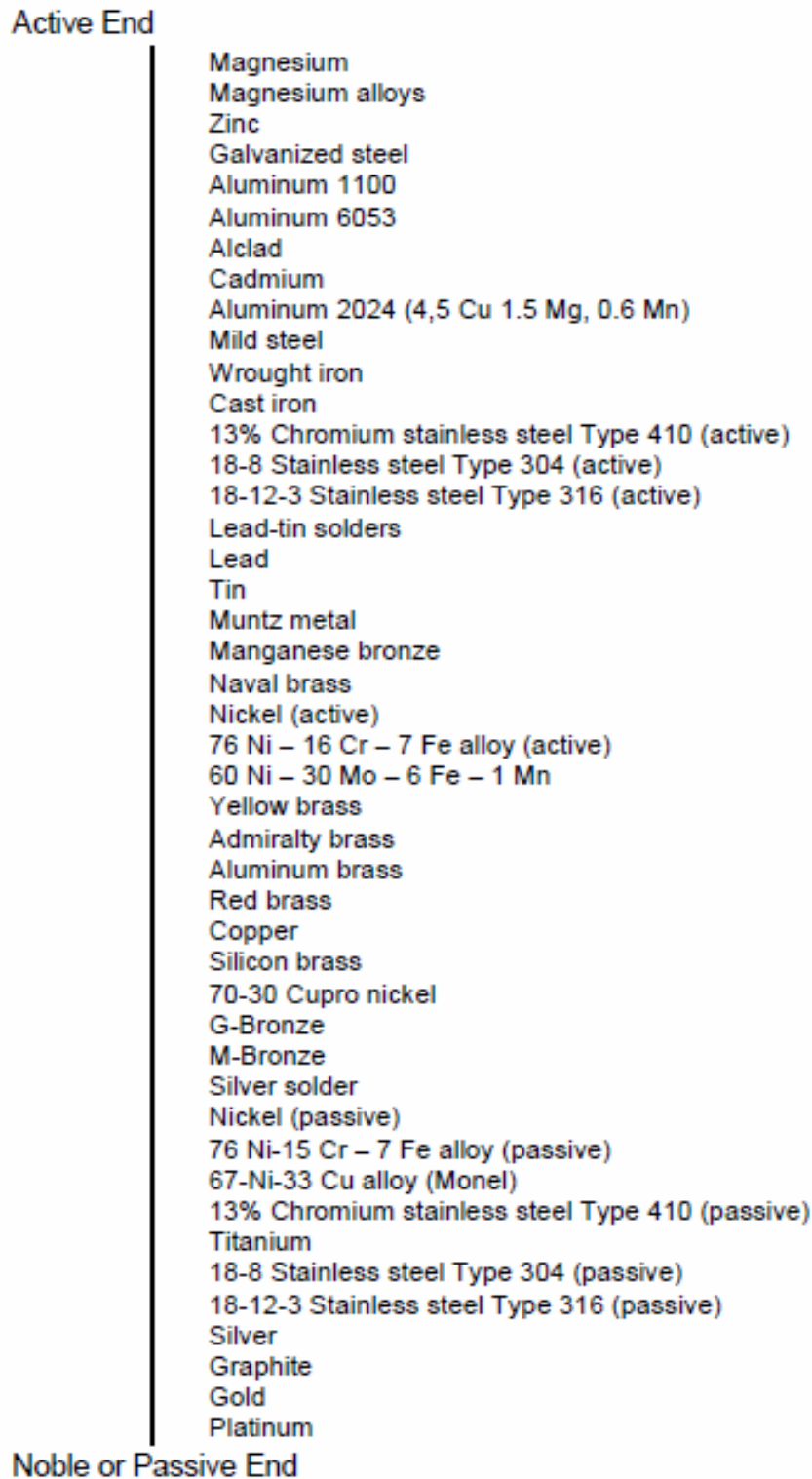

Figure 18

Galvanic series of common metals and alloys found in cooling water systems

**5.3.2 UNDER-DEPOSIT CORROSION.** See Figure 17 (C). The term “under-deposit corrosion” refers to corrosion occurring under any type of deposit. The underside of a deposit that has been caused by fouling, bacterial slime, or debris acts in much the same way as the inside of a crevice. The metal under the deposit becomes anodic and corrodes. This process is considered another form of concentration cell corrosion because oxygen cannot easily get under the deposit. All metals are susceptible to this type of corrosion, which results in localized or pitting attack.

**5.3.2.1 MICROBIOLOGICALLY INFLUENCED CORROSION (MIC).** See Figure 17 (E). This term refers to metal corrosion associated with microbiological organisms whose presence contributes to the creation of, or maintenance of, a corrosive environment. MIC can be either eliminated or prevented to a large degree by the proper use of biocides.

**5.4 CORROSION RATE.** The term “corrosion rate” refers to the rate at which the corrosion action proceeds. The rate is measured in units of mils per year (mpy). A mil is 0.0254 millimeter (one-thousandth of an inch). The rate measurement is performed using corrosion coupons that have been exposed to cooling water for a short period of time (i.e., 30 to 90 days). The weight of the coupon is measured before and after exposure to the water. The thickness of the metal lost due to corrosion over the testing period is then calculated using a measurement of the weight loss. This weight loss is extrapolated to give a rate for 1 year and a calculation of the thickness loss is then performed and the value is reported. Alternatively, this measurement can be taken using specialized instruments that rapidly measure corrosion rates. 9 shows the corrosion rates for corrosion coupons of different metals.

Metal	mpy	Comment
Mild steel piping	< 1	Excellent
	> 1 to 3	Good
	> 3 to 5	Fair
	> 5 to 10	Poor
	> 10	Unacceptable
Mild steel Hx tubing	< 0.2	Excellent
	> 0.2 to 0.5	Good
	> 0.5 to 1.0	Fair
	> 1.0 to 1.5	Poor
	> 1.5	Unacceptable
Copper and copper alloys	< 0.1	Excellent
	> 0.1 to 0.2	Good
	> 0.2 to 0.3	Fair
	> 0.3 to 0.5	Poor
	> 0.5	Unacceptable
Galvanized steel	< 2	Excellent
	> 2 to 4	Good
	> 4 to 8	Fair
	> 8 to 10	Poor
	> 10	Unacceptable
Stainless steel	< 0.1	Acceptable
	> 0.1	Unacceptable

NOTE: Determine pitting on coupons by visual observation; any pitting is unacceptable.

Table 9

Assessing Corrosion Rates in Cooling Water Systems: 90-Day Corrosion Coupon Test

**5.5 CORROSION CONTROL METHODS.** In cooling water systems, two basic techniques are used to provide corrosion protection to the metals that the water contacts: use of chemical corrosion inhibitors, and raising the pH of the cooling water. Figure 19 illustrates the effect of pH on the corrosion rate of mild steel. Many cooling water systems contain components fabricated primarily of copper alloy and mild steel. Galvanized steel is present in galvanized cooling towers and stainless steel may be

present in piping. As the cooling water pH is increased (ideally to within the range of 8.0 to 9.5), copper and mild steel corrosion rates will decrease as shown in Figure 19, although very high pH levels are corrosive to copper. The increase in pH alone cannot always protect metals adequately, especially since cooling water is highly aerated (oxygen saturated). Chemical corrosion inhibitors are used to provide protection from corrosion of the metal components of cooling water systems. Table 10 shows criteria for the selection of corrosion inhibitors. The principal strategy for a cooling system corrosion protection program is to ensure protection of the metal in the heat exchanger (metal that is the thinnest metal in the system). The secondary goal is to provide protection from corrosion of the mild steel piping. When galvanized steel cooling towers are part of the cooling system, specialized corrosion inhibitors are the best control method. Galvanized steel is corroded at pH levels above 9.0 and below 6.0.

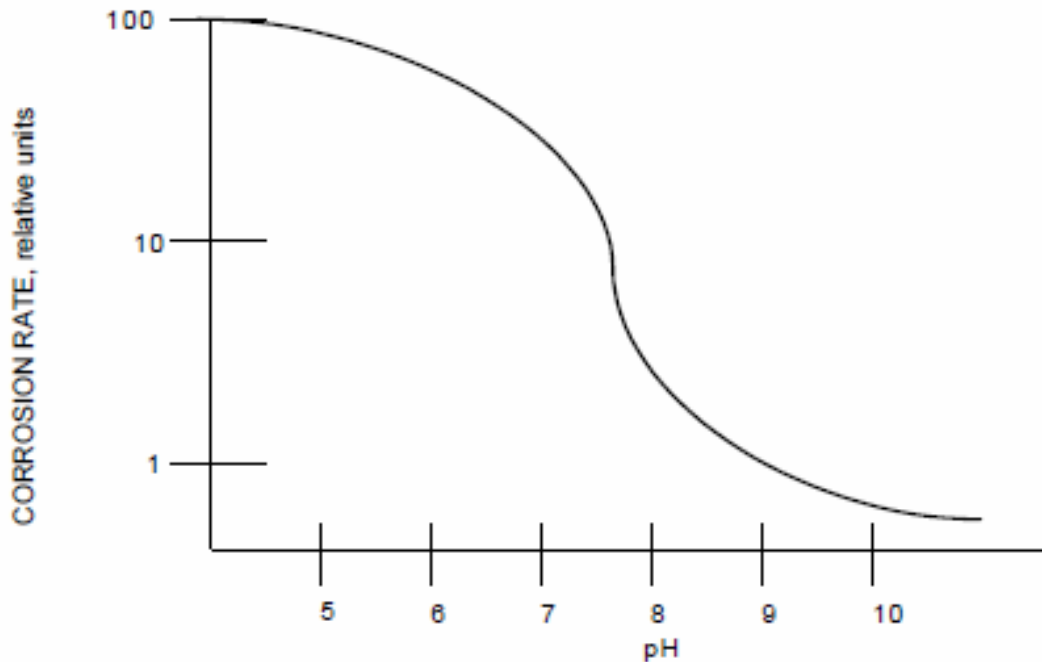

Figure 19  
Effect of pH on corrosion rate of unprotected mild steel in water

Corrosion Inhibitor	Metal			pH Range (ideal)
	Steel	Copper	Aluminum	
Cathodic Inhibitor				
Polyphosphate <sup>1</sup>	Excellent	Attacks	Attacks	6.5-8.5
Zinc salts <sup>2</sup>	Excellent	None	None	6.5-8.5
Polysilicate <sup>3</sup>	Excellent	Excellent	Excellent	7.5-10.0
Molybdate	Good	Fair	Fair	7.5-10.0
Anodic Inhibitor				
Orthophosphate <sup>1</sup>	Good	Attacks	Attacks	6.5-8.5
Orthosilicate <sup>3</sup>	Good	Good	Good	7.5-10.0
Copper Corrosion Inhibitor				
Azoles	Fair	Excellent	Fair	6.0-10.0

NOTES:

1. May require polymeric calcium phosphate dispersant.
2. Rarely used alone. Requires zinc solubilizer above pH 7.8.
3. Do not use if natural silica is 150 ppm or greater.

Table 10

Criteria for corrosion inhibitor selection

**5.5.1 EFFECTIVE CORROSION CONTROL.** Effective corrosion control requires maintaining appropriate pH levels, plus adding maintenance dosages of chemical corrosion inhibitors. Chemical corrosion inhibitors form a protective film or barrier on the cooling system metal surfaces that have been cleaned prior to adding an initial high dosage of inhibitor. The initial high dosage of inhibitor passivates (protects) the metal. The appropriate dosage of corrosion inhibitor must be maintained continuously in the cooling water to ensure continuing protection. Table 11 shows examples of various passivation and maintenance dosage levels of corrosion inhibitors. Corrosion inhibitors are divided into three classes: cathodic, anodic, and general filmers. Corrosion inhibitors form a protective film on either the anode, the cathode, or over the entire metal surface. The types of corrosion inhibitors are described below.

**5.5.1.1 ANODIC INHIBITORS.** Anodic inhibitors form a protective film coating on the anodic metal (where the metal is lost) and thus directly control corrosion by preventing

the reaction that results in corrosion. Any unprotected areas will corrode at a much faster rate than the protected areas, a factor that could result in pitting or localized attack of the unprotected areas. Examples of anodic inhibitors include orthophosphate, nitrite, and orthosilicates. Under certain conditions, molybdate can function as an anodic inhibitor.

**5.5.1.2 CATHODIC INHIBITORS.** Cathodic inhibitors form a protective film coating of the cathodic metal (where metal is not lost) and thus indirectly prevent corrosion by interfering with the current flow required for the electrochemical reaction to proceed between the cathodic and anodic metals. The corrosion reaction rate is governed by the size and type of the cathode relative to the anode. Even when cathodic areas are not completely covered by the protective film, corrosion will occur, but usually more slowly and uniformly than when using anodic inhibitors alone. The occurrence of localized corrosion or pitting attack is greatly reduced. Examples of cathodic inhibitors include zinc salts, polyphosphates, and polysilicates. Under most conditions, molybdate will function as a cathodic inhibitor.

**5.5.1.3 GENERAL INHIBITORS.** General inhibitors produce a protective film on the surfaces of all metals. These corrosion inhibitors are organic compounds, such as certain phosphonates, amines, and other nitrogen chemicals. They may be used in cooling water systems.

**5.5.1.4 CORROSION INHIBITORS FOR SPECIFIC METALS.** Some corrosion inhibitors provide corrosion control for specific metals. The protection of copper and copper alloys requires the use of azoles, such as tolyltriazole (TTA), benzotriazole (BZT), and butylbenzo-thiazole, which can be added to the system separately from, or as part of a blend of, other treatment chemicals.

**5.5.1.5 GALVANIC OR CREVICE CORROSION.** Control of galvanic or crevice corrosion is achieved primarily by engineering and mechanical design. These types of corrosion can also be partially controlled by physical and chemical considerations. A

dielectric coupling (insulator), used to separate two different metallurgies, can help to prevent galvanic corrosion. From a chemical perspective, adjusting pH and using proper corrosion inhibitors will reduce corrosion.

**5.5.1.6 DEPOSIT CORROSION.** Control of deposit corrosion requires maintaining deposit-free metal surfaces. This applies to any form of deposit, such as scale, biomass, corrosion products, or foulants. The occurrence of most types of deposits is prevented by dispersants, scale inhibitors, or biocides, along with the maintenance of adequate flow velocities. Routine, adequate cleaning of filters and tower sumps will help reduce deposits.

**5.5.1.7 MIC.** MIC is best prevented by stopping conditions that foster biological growth and by using an effective microbiological control program. A MIC prevention program includes adequate control (prevention) of deposits and fouling, avoidance of low-flow and dead-leg conditions, and implementation of a consistently effective microbiological program.

Corrosion Inhibitor	Dosage (ppm)		Film-Formation Time (Days)
	Initial	Maintenance	
Cathodic Inhibitor			
Polyphosphate <sup>1</sup>	40-60 as PO <sub>4</sub>	10-20 as PO <sub>4</sub>	5-6
Zinc salts <sup>2</sup>	10-20 as Zn	3-5 as Zn	5-6
Polysilicate <sup>3</sup>	40-60 as SiO <sub>2</sub>	10-20 as SiO <sub>2</sub>	10-12
Molybdate	40-60 as Mo	5-20 as Mo	10-12
Anodic Inhibitor			
Orthophosphate <sup>1</sup>	40-60 as PO <sub>4</sub>	15-20 as PO <sub>4</sub>	5-6
Orthosilicate <sup>3</sup>	40-60 as SiO <sub>2</sub>	10-15 as SiO <sub>2</sub>	10-12
Copper Corrosion Inhibitor			
Tolytriazole	10-20 as TTA	1-2 as TTA	5-6

- NOTES: General: Maintenance dosage shifts to lower part of range as pH rises.
1. May require polymeric calcium phosphate dispersant.
  2. Rarely used alone. Requires zinc solubilizer above pH 7.8.
  3. Do not use if natural silica is 150 ppm or greater.

Table 11  
Guidelines for Passivation Film Formation and Subsequent Maintenance

**6. DEVELOPING AN EFFECTIVE COOLING WATER TREATMENT PROGRAM.** An effective and complete cooling water treatment program addresses many factors, including those associated with compliance and safety, protection of equipment, and cost. Compliance and safety considerations are mandatory components of the program. Achieving or exceeding minimally acceptable equipment protection at the lowest possible cost is an advisable outcome for a well-designed program. The overall cost of the treatment program includes not only the cost of chemical treatment, but also the costs of water, disposal, manpower, and equipment. Development of an appropriate cooling water treatment program is dependent upon knowledge of both the specific equipment to be protected and the quality of the water to be used (source water and system water).

**6.1 EQUIPMENT.** Corrosion inhibitors are selected based on the metallurgy of individual pieces of cooling system equipment. Typical systems include equipment components of different metals. For example, systems may include smooth and enhanced copper tube bundles, mild steel transfer piping, and galvanized cooling tower components; therefore, to select the proper corrosion inhibitor, it is important to identify all metals contacted by the cooling water. (See Table 10 for corrosion inhibitor selection criteria.)

**6.2 OPERATIONAL FEATURES AND PARAMETERS.** Operational features and parameters of the cooling water system must be known to select the proper scale and deposit inhibitors. This requirement refers to operational parameters such as maximum temperature, minimum velocities, usage patterns, and whether or not layup periods occur. The best chemical treatment programs cannot overcome the stresses of poorly operated systems. A good example of system stress is intermittent chiller operation that allows for SS accumulation (deposits) in chiller tube surfaces due to low flow or lack of flow. This situation creates a strong potential for under-deposit corrosion and for MIC that the chemical treatment may not be able to overcome completely.



Stagnant water can also cause deposits and corrosion. High water temperatures can cause scale. The maximum water temperature should be known so that the proper scale-control method can be used.

**6.3 WATER QUALITY.** Water quality within the cooling water system is a critical consideration. The source may be potable or reuse or recycled water. The various water constituents must be known so appropriate water treatment chemicals can be selected for controlling specific water quality parameters.

## **6.4 COOLING WATER TREATMENT PROGRAMS**

**6.4.1 CATEGORIES.** For the purpose of developing a water treatment program, cooling tower recirculating water systems can be divided into three basic categories:

- Small-sized towers – capacity less than 88 kilowatts (25 tons)
- Medium-sized towers – 88 to 352 kilowatts (25 to 100 tons)
- Large-sized towers - greater than 352 kilowatts (100 tons)

The water treatment program selected for cooling tower systems will vary depending on the size of the tower (among other factors). Treatment program considerations are described in paragraphs 6.5 and 6.6 for small-, medium-, and large-sized towers, respectively.

**6.4.2 CYCLES OF CONCENTRATION (COC).** The COC of small, medium, and large cooling towers may be controlled by blowdown, either automatic or manual, to avoid the high levels of silica and calcium salts that can lead to scale. If the cooling tower is not chemically treated, the COC should be adjusted to be slightly less than the lowest allowable COC value based on all scale-forming water ingredients. The use of chemical treatment permits a higher COC, which is usually limited by either the chemical effectiveness or the water treatment control.

EXAMPLE: An untreated cooling tower system can operate at 10 COC based on the level of silica without scale forming, but can operate at only 2 COC based on the level of calcium carbonate. Accordingly, the tower system should be operated at a maximum of 2 COC. The system can likely be operated at 5 to 6 COC when an effective chemical treatment is applied and maintained to control calcium carbonate.

**6.5 TREATMENT PROGRAM FOR SMALL COOLING TOWERS.** Typically a small cooling tower will have a rating of less than 88 kilowatts (25 tons). The treatment program used for small towers should be designed to be simple to control and easy to apply, with very little operator attention required. This does not mean that no attention is required, only less than that required for medium-sized systems. The treatment program for small systems is shown in Table 12.

Parameter	Method
COC	Do not exceed COC limits for untreated water
Scale and corrosion program	Dry slowly soluble phosphate compound
Microbiological program	Dry slowly soluble oxidizing biocide
SS	Filtration and periodic washdowns, as required

Table 12  
Small Cooling Tower Treatment Program

**6.5.1 TREATMENT.** Small systems can be treated with a low dosage (5 to 10 ppm) of a slowly soluble phosphate chemical (sodium/calcium polyphosphate) by placing a nylon mesh bag containing the product into the cooling tower. The product, if applied in this manner, will usually provide adequate scale and corrosion control.

Microbiological control can be obtained by use of a dry, pelletized, oxidizing biocide, such as bromo-chlorohydantoin or isocyanuric acid plus sodium bromide (see paragraph 4-4.4.1). Either of these biocides can be fed continuously via a feeder or suspended in a mesh bag in the cooling tower water. The cooling tower sump should be kept clean of SS and other debris by use of a filter and periodic washdowns.

**6.5.2 TESTING.** Testing is usually limited to assurance that the optimum COC value is being maintained and that the chemical treatment agents are present in the water. The bag with the chemical treatment should not be allowed to become less than one-half full. The frequency for refilling the bag will vary; once every 1 to 2 months is typical. Initially, the treatment level should be checked to assure that adequate, but not excessive, levels of both phosphate and the biocide are present in the cooling water.

**6.6 TREATMENT PROGRAM FOR MEDIUM AND LARGE COOLING TOWERS.** The chemical treatment program for these cooling tower systems (typically greater than 88 kilowatts [25 tons]) requires sufficient, regular testing as well as water and chemical control to protect the equipment in contact with the cooling water. Usually treatment includes control of scale, fouling, microbiological growth, and corrosion. The composition of an optimum chemical treatment program for cooling towers on a military installation depends on the quality of water available, the operating conditions of the cooling system, and the environmental constraints placed on treatment chemicals in the blowdown water (effluent discharge limitations). Conditions at a particular installation may require variation of the quantity or mix of the chemicals suggested in Table 13.

**6.6.1 TREATMENT.** Medium and large cooling towers are usually, but not always, treated with a liquid formulation containing both scale inhibitors and corrosion inhibitors. These are often simply referred to as an "inhibitor." Inhibitor products are usually fed on a continuous basis using automated control and feed equipment. The concentration of these formulated products varies greatly from vendor to vendor. Biocides are usually, but not always, liquid products. It is common to use an oxidizing biocide as a primary biocide and a non-oxidizing biocide as a secondary biocide, used as needed to control bacteria and other biological growth. Oxidizing biocides can either be fed continuously at a low level or dosed periodically at a higher level. Non-oxidizers are dosed as needed and only when oxidizing biocides are either ineffective or not used at all.

Parameter	Approach
COC	Target a minimum of 3 COC (ideally 5 COC) that the chemical treatment will allow.
Corrosion control	1. Use of cathodic corrosion, possibly supplemented with anodic inhibitors for mild steel. If a galvanized cooling tower is present, use a polysilicate or low-level phosphate while keeping pH in the range of 8 to 9. 2. Copper corrosion inhibitor should be used for all copper tubes and especially for enhanced and super-enhanced copper tubing.
Scale control	Phosphonate/polymer program, augmented by a phosphate dispersant if phosphate corrosion inhibitor is used.
SS	Polymer dispersant coupled with adequate flow. Avoid no-flow conditions in heat exchangers as much as possible. Mechanical filtration and routine physical sump cleaning recommended.
Microbiological control	1. Primary biocide: oxidizing biocide using continuous feed or slug feed as an alternate. 2. Secondary biocide: non-oxidizing biocide using slug feed, as required.

Table 13

Treatment programs for medium and large cooling towers

**6.6.2 TESTING.** Testing should be done regularly to insure that COC, chemical levels, and bacteria levels are within the targeted control range. This requirement could demand a testing frequency of 3 times per week, or even daily.

**6.7 COOLING TOWER OPERATOR DUTIES.** If detected early, problems associated with scaling, corrosion and fouling in a cooling tower system can be minimized by corrective action. Some of the things the operator should look for when on-site are described below.

**6.7.1 COOLING TOWER DISTRIBUTION DECK.** It is important to look for the presence of algae, debris, or anything that has plugged water distribution holes causing an uneven water flow through the tower, thus lowering tower efficiency. Clean plugged holes and replace damaged water distribution spray nozzles.

In addition, look for the presence of algae deposits. If algae deposits are present, increase the level or frequency of biocide or algaecide treatment, and cover the deck if uncovered.

## **6.7.2 COOLING TOWER FILL, AIR INTAKE SLATS, AND BASIN**

**6.7.2.1 SCALE DEPOSITS ON COOLING TOWER FILL.** The presence of deposits, particularly on cooling tower fill, can be established by removing some fill to determine if partial plugging has occurred. Scale can range in color from white to gray or reddish depending on the scale composition. Scale formation on the cooling tower fill usually indicates a severe scaling situation. If possible, obtain a sample of the scale for analysis and, based on the result, select a scale inhibitor for that specific scale.

**6.7.2.2 SCALE DEPOSITS ON AIR INTAKE SLATS.** Scale can form on the air intake slats of a cooling tower. This buildup is due mostly to water splashing and evaporating, causing deposition of soluble salts or minerals. This situation does not indicate a serious problem. These deposits can be, and should be, washed off periodically, but ideally not into the cooling tower basin. Chemical treatment can provide some reduction in the occurrence deposits.

**6.7.2.3 SLIME DEPOSITS.** Slime deposits (microbiological) can sometimes be detected by feeling below the water level on the distribution deck and on the walls of the cooling tower basin. Most microbiological growth will have a slimy feel. If slime deposits are present, increase biocide frequency or increase the dosage.

**6.7.2.4 SUSPENDED SOLIDS.** The purpose of a dispersant is to keep particulate solids in suspension and to prevent them from settling or from adhering to heat transfer surfaces. Adequate water flow is required to prevent them from settling. Particulate solids in suspension are removed with the blowdown water. The tower water should be turbid if the dispersant is doing its job. Keep the cooling tower sump clean of SS by cleaning periodically and using a filter.

**6.7.3 CORROSION TEST COUPONS.** When removing corrosion coupons, always note and record the visual appearance with regard to the presence of scale, rust, or biomass. Take photographs of the corrosion coupons. Submit (or evaluate) coupons for corrosion rate and for the type of corrosion that is occurring.

**6.7.4 INSIDE SURFACE OF HEAT EXCHANGER TUBES.** To effectively examine the inside (water-contacted) surfaces of heat exchanger tubes, a boroscope is needed because only a few inches of the interior can be seen visually using a flashlight. Scale deposits, typically hard and tightly adhered to the tube surface, range in color from white to gray or reddish, depending on the composition of the scale. No scale should be present. It is important to inspect heat exchanger tubes at least once per year. Fouling-type deposits may look similar to scale deposits. Unlike scale, these deposits usually adhere loosely to the tube surface. Biomass will appear slimy and feel slippery, and will usually adhere loosely.

**6.7.5 CHILLER PERFORMANCE.** Degradation of chiller performance or chiller efficiency may be a strong indication of scale or fouling problems in the chiller. If a reduction in chiller capacity occurs while cooling water is being cooled efficiently and within design parameters, then the chiller condenser section should be opened and examined. The chiller evaporator section may not contain water material scale but may be fouled with corrosion products. You should open and examine the chiller evaporator if chilled water could possibly be inadequately treated.

**6.7.6 COOLING TOWER SURFACES.** Cooling towers made of galvanized steel should be examined for white rust or possible rusty surfaces that may indicate that the galvanizing is no longer present on the metal surfaces and the steel is rusting. Cooling towers constructed of wood should be examined for wood deterioration or decay.

**7. COOLING WATER SYSTEM START-UP AND LAYUP REQUIREMENTS.** The startup of a new cooling water system requires special consideration. Proper cooling water system layup is also important, especially for chiller tube bundles or other heat exchange equipment. For a new cooling tower system, it is important to make sure that the equipment that contacts the cooling water is clean and properly protected from initial corrosion. Also, disinfection is needed to eliminate the presence of microbiological organisms that can cause corrosion, deposits, and growth of pathogenic organisms such as Legionella bacteria. Implementation of a proper layup process is critical to prevent corrosion and microbiological growth during stagnant water conditions.

**7.1 STAND-BY CONDITIONS.** The term “stand-by” is often applied to a chiller that is in rotation with other chillers on-line. This stand-by period could be of varying duration, from a few days to a few weeks. Rotating chillers frequently is important for minimizing stagnant conditions that lead to under-deposit and MIC corrosion. It is good practice to run the recirculation pumps through a stand-by chiller for at least 15 minutes each day to minimize corrosion. A chiller that must be left on stand-by for an extended period of weeks without recirculation should be laid up wet or dry according to procedures described in paragraph 7.4.

**7.2 COMMON PROBLEMS DURING LAYUP OR DUE TO IMPROPER INITIAL START-UP.** Common problems that occur during layup or due to improper initial start-up include corrosion of tubes and transfer piping (sometimes to the point of failure), micro-biological growth with potential for MIC corrosion, and growth of pathogenic microorganisms.

### **7.3 START-UP OF NEW COOLING WATER TOWER SYSTEMS**

**7.3.1 INITIAL CLEANING.** A new cooling water tower system will contain dirt, oils, greasy films, and rust located on the metal surfaces as a result of system fabrication.

A pre-operational alkaline cleaning process is required to remove the dirt, oil, grease, and rust, and to prepare metal surfaces for initial corrosion control. When galvanized steel is involved, special care must be taken so that the pH does not exceed 8.5 during the cleaning and passivation process to avoid conditions that promote white rust. The cleaning and passivating procedure for a new cooling tower system is usually part of a new system construction project and, as such, is not in the direct control of the cooling system operations personnel. Verification of the completion of these important steps is obtained from the contracting officer involved with the project. A cleaning and passivation procedure for cooling tower systems with galvanized steel is provided below. The procedure is similar for systems that do not contain galvanized steel, except that the pH restriction does not apply.

**7.3.2 CLEANING AND PASSIVATION PROCEDURES.** In the startup of new cooling tower systems containing complex metallurgies that include galvanized steel, follow the cleaning and passivation procedures for cooling tower systems containing galvanized steel, stainless steel, mild steel, or copper. These procedures should not be used for cleaning and passivating aluminum. Conventional chemical cleaners and typical heating, ventilation, and air conditioning (HVAC) water treatment programs use highly alkaline, high-pH water, which can initiate white rust formation on galvanized surfaces and copper tubes. Galvanized steel can simply be passivated by exposure to highly aerated water and a phosphate or polysilicate treatment. This treatment forms a zinc corrosion inhibition layer, which is a natural, dense, adherent, and protective corrosion product film. High pH (above 8.5) produces unwanted white rust that is fragile and not protective against corrosion. The following procedures are recommended.

#### **7.3.2.1 HYDROSTATIC TESTING. PERFORM HYDROSTATIC TESTING:**

- a) Inspect and remove all debris.



b) Fill the system with treated water and circulate. This should include orthophosphate or hexametaphosphate (as PO<sub>4</sub>) at 40 to 60 ppm, and tolyltriazole (active) at 10 to 20 ppm.

**7.3.2.2 PRE-OPERATIONAL CLEANING PROCEDURE.** If the system passes hydrostatic testing, proceed immediately to this pre-operational cleaning and passivation procedure. Do not allow untreated water to be added to the system.

- a) Drain and flush any debris from hydrostatic testing.
- b) Dose and circulate (for 24 hours) a sufficient amount of a cleaning formula based on the volume of the system. A formulation is provided below.
- c) Drain and flush the system, and clean all strainers.
- d) Fill the system with makeup water and circulate for 30 minutes.
- e) Take a sample of system water while it is circulating. The sample should match the makeup water supply for clarity and SS; conductivity  $\pm 10\%$ ; and pH  $\pm 0.3$  pH units from 7.5 to 8.5.

If necessary, repeat steps a) through e) until the system water matches this description. The system should now be clean and passivated.

**7.3.2.3 CHEMICAL CLEANING AND PASSIVATION FORMULATION.** Apply this chemical cleaning and passivation formulation when the water system pH is 7.5 to 8.5; adjust pH as required. Formulation limitations may require adding separate components to keep things in solution. Other formulations may be used.

- Orthophosphate (or) hexametaphosphate (as PO<sub>4</sub>): 60 ppm
- Polyacrylate (active): 20 ppm
- Tolyltriazole (active): 10 ppm
- Sodium gluconate: 50 ppm
- Pluronic L-61 (active) (non-ionic surfactant with antifoam): 400 ppm
- Phosphate scale inhibitor: 50 ppm

**7.3.2.4 PASSIVATION OF THE SYSTEM.** Supplemental corrosion inhibitors may be used in conjunction with the phosphate but are not required. Maintain and circulate the levels for the time required. After passivation, proceed to operational readiness or layup as required. Tables 4-14 and 4-15 show chemical technology used for passivation.

**7.3.2.5 OPERATIONAL READINESS.** If system operation is not required for a period of a week or more, proceed to layup. For normal operation, allow corrosion inhibitor levels to subside to maintenance levels through normal blowdown. Proceed to maintenance water treatment program.

Inhibitor	Dosage	pH	Film Formation
Polyphosphate	40-60 ppm as PO <sub>4</sub>	6.5-7.9	14-21 days
Orthophosphate	20-30 days as PO <sub>4</sub>	6.5-7.9	14-21 days
Tolytriazole	10-20 days as TTA	6.5-7.9	14-21 days

Table 14  
Required Chemical Technology

Inhibitor	Dosage	pH	Film Formation
Zinc	10-20 ppm as Zn	6.5-7.5	14-21 days
Polysilicate	40-50 ppm as SiO <sub>2</sub>	7.5-8.5	14-21 days
Molybdate	40-60 ppm as Mo	7.5-8.5	14-21 days

Table 15  
Supplemental Chemical Technology

## 7.4 LAYUP OF COOLING TOWER SYSTEMS

**7.4.1 WET LAYUP OF COOLING WATER SYSTEMS AND EQUIPMENT.** Systems and system equipment such as heat exchangers, chiller tube bundles and the like can

be laid up wet, but first they require a physical cleaning to remove all suspended materials. Apply corrosion inhibitors at increased dosages, usually at a level of about 4 to 5 times the normal maintenance dosage. Apply an increased dosage (within EPA limits) of a non-oxidizing biocide that has a long half-life, such as glutaraldehyde or isothiazolone.

**7.4.2 DRY LAYUP OF COOLING WATER SYSTEMS AND EQUIPMENT.** Systems and equipment can be laid up dry, although dry layup is more appropriate for a single piece of equipment, such as a chiller's condenser tube bundle or other heat exchanger. All metal surfaces must be completely dry; residual moisture is not acceptable. In humid climates you should use a desiccant such as a quicklime gel or an equivalent. Place the desiccant in as many locations as necessary and replace as required.