



PDHonline Course S120 (1 PDH)

Metal Building Systems

Instructor: Matthew Stuart, PE, SE

2020

PDH Online | PDH Center

5272 Meadow Estates Drive
Fairfax, VA 22030-6658
Phone: 703-988-0088
www.PDHonline.com

An Approved Continuing Education Provider

Discussion:

Although commonly referred to as pre-engineered buildings in the past, today metal-building systems are the preferred vernacular used by the industry for this economical method of providing a low-rise building enclosure. Pre-Engineered Metal Building (PEMB) is also a common term used to describe this type of steel construction. Among the most basic project requirements affecting the choice of a framing system is the size of the building in question. Another is the desired roof slope. In addition, the presence (or lack) of interior columns becomes a design consideration. Once these variables are known, it is easy to determine which style of framing would be the most appropriate.



Source: Olympia Steel Buildings

Manufacturer-specific names aside, there are really only a handful of different types of metal building framing packages. It is from these various styles that any building package can then be custom created per customer needs. Generically, these systems are known as: tapered beam; single-span rigid frame; multi-span rigid frame; single-span and continuous truss; and lean-to. Most, if not all, can be supplied with either a single-or double-sloping roof profile.



Rigid Frame
Source: Dongbu Steel

Metal building frames are usually fabricated from plate and bar stock having a yield strength of 50 ksi. The member depths and the plate thickness are determined by computer analysis in order to make the most efficient use of material. Tapering of the structural members enables the largest amount of material to be incorporated at the points where bending moments are highest.



Tapered Beam
Source: Timeline Builders

Framing members are fabricated to include pre-punched splice plates that enable them to be quickly and easily erected at the job site. Two types of connections are routinely used: simple (hinged or pinned) and moment (rigid). Simple connections permit members to rotate relative to one another, and have the capacity to transfer shear and axial forces only. Moment connections, on the other hand, join members in such a way that bending or flexural moments can be transferred from one member to the other. Simple connections usually require fewer bolts and thinner plates, thus making it the less expensive of the two. The primary members of a rigid frame package (the columns and beams) typically feature end plate moment connections while the secondary structural members (purlins and girts) utilize simple connections. Some PEMB manufacturers utilize trussed girders and open web joist construction.



Source: Coronis Building Systems

Although manufacturers or their representatives should always be contacted for assistance with the selection of the type of framing, the various types do have some general characteristics by which they can be identified. A description of each of the types follows.

Tapered Beam:

Tapered beam systems, also referred to as wedge beam or slant beam packages, are often utilized where clear span requirements are moderate and straight columns are a necessity. Their characteristics make them popular choices for small commercial office buildings and various types of retail stores. Like the interior planes of the columns, the undersides of the beams utilized with this type of framing system can also be straight. The taper then occurs on the top side, generally at a rate of about 1:12 achieving a maximum depth at the midspan. The column-to-girder connections are designed to resist moments due to lateral loads only. A less common version of this framing type utilizes girders that resemble scissor trusses. For this type of framing, both the top and bottom flanges of the girders are sloped. This configuration becomes especially useful for projects that require both a sloped roof and modestly sloped cathedral-type ceiling. The beams are usually spliced at midspan. Buildings constructed with this type of framing system usually range in width from 30' to 60' and have eave heights of 20' or less.

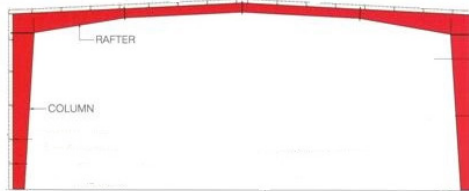

Source: Mabani Steel

Single-Span Rigid Frame:

Single-span rigid frame systems are popularly used for a whole host of projects ranging from auditoriums and gymnasiums to aircraft hangars, retail showrooms, churches, recreational facilities and warehouses. One of the defining characteristics of these types of packages is their column-free interior spans.

In contrast to the tapered beam systems, single-span rigid frame packages are designed to take full advantage of connection rigidity. The framing members are tapered to mimic the shape of the bending moment diagrams. The deepest part of the frame is the knee, at the beam and column joint. For a two-hinge frame, the framing is most shallow approximately midway between the knee and the ridge. For the less-common three-hinge frame, the shallowest section appears at the ridge. The splices are made at the knee, at the ridge, and depending upon the frame width sometimes elsewhere in the rafter.



Source: Titus Steel Buildings

One of the most popular styles of rigid frame systems is that which features a gabled roof. This type of frame is very cost efficient as less material is required than most of the other structural systems for the same span and eave height. Metal Building Systems Design and Specifications, by Alex Neuman, indicates that a two-hinged gabled style rigid frame system spanning 60', with an eave height of 14' and ridge height of 24', is 19% more efficient than a similar sized low-slope rigid frame and 53% more efficient than a statically determinate frame designed on the simple-span principle. The rigid frame approach is best utilized for buildings requiring a clearspan width of between 60' and 120' and eave heights between 10' and 24'. Its use also requires that tapered beams be acceptable and headroom at the exterior walls not necessarily critical.



Source: Capital Steel Buildings

Multi-Span Rigid Frames:

Multi-span rigid frame systems are also widely known as continuous beam, post-and-beam and modular frame systems. They are suitable for projects where interior columns are not objectionable. The interior columns allow the girder sizes to be reduced, which makes this frame more economical than clear span packages in many instances. In these types of framing systems both the exterior columns and girders are generally tapered while the interior columns are straight. This type of framing system is often the only solution for the largest of buildings such as warehouses, distribution centers and factories. Multi-span systems utilize continuous framing and are normally more economical than single-span systems. The worse drawback associated with these systems is that the locations of interior columns are difficult to change at a later date. The multi-span rigid system is best utilized for buildings requiring a clearspan width of between 60' and 120' and eave heights between 10' and 24'.



Source: Zamil Steel

Single-Span and Continuous Truss:

Single-span and continuous truss systems are similar in function to single-span and multi-span rigid frames. The crucial difference between trusses and frames lies in the construction of the rafter's open web for trusses and solid web for frames. An open web allows for passage of pipes and ducts and thus permits the eave height in a truss building to be lower, which results in a smaller building volume to be heated or cooled and thus in lower energy costs. Therefore, trusses are most appropriate for applications with a lot of piping and utilities, such as manufacturing facilities and distribution centers. The single span truss frame is best utilized for buildings requiring a clearspan width of between 30' and 60' and eave heights of 24' or less.

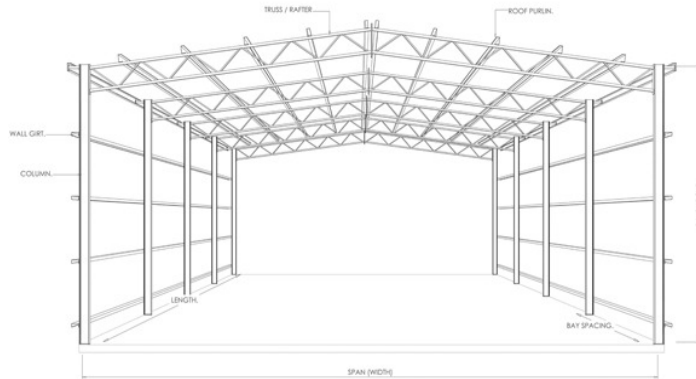

Source: Action Steel

Lean-To:

Lean-To systems are "add on" items. They normally are designed for vertical loads only, and rely on an adjacent structure for lateral support. Tapered beams and straight columns are usually used. For optimum efficiency, the system is best specified for clear spans from 15' to 30'. Lean-to framing is typically used for building additions, equipment rooms, storage, and a host of other minor attached structures. Structural details are similar to those of a tapered beam system, except that a single slope is usually provided at the top surface and the beam taper precludes the bottom surface from being horizontal.

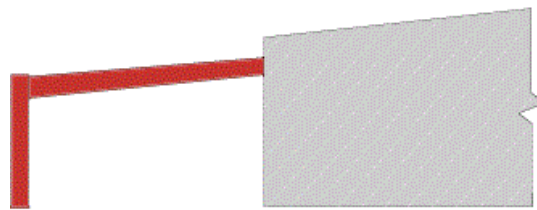

Source: Zamil Steel

The follow table provides a summary of the different types of PEMB frames and the corresponding most economical range of spans:

BUILDING TYPE	ROOF SLOPE	WALL HEIGHT (FT)	BAY SPACING (FT)	MOST ECONOMICAL SPAN FOR EACH BUILDING TYPE (FT)																							
				20	30	40	50	60	70	80	90	100	110	120	130	140	150	160	170	180	190	200	210	220	230	240	
	1/12	10	20																								
		12																									
		14																									
		16																									
		20		25																							
	1/12	10	20																								
		12																									
		14																									
		16																									
		20		25																							
	4/12	10	20																								
		12																									
		14																									
		16																									
		20		25																							
	1/12	10	20																								
		12																									
		14																									
		16																									
		20		25																							
	1/12	10	20																								
		12																									
		14																									
		16																									
		20		25																							
	1/12	10	20																								
		12																									
		14																									
		16																									
		20		25																							
	1/12	10	20																								
		12																									
		14																									
		16																									
		20		25																							
	1/12	VARIES WITH SPAN	20																								
		25																									

Secondary Members:

Common secondary member ranges and types are as follows;

- Z-purlin – 30’ maximum span



Source: Fairdeal Industries

- Girt types include flush, semi-flush or offset (referred to as bypass girts)

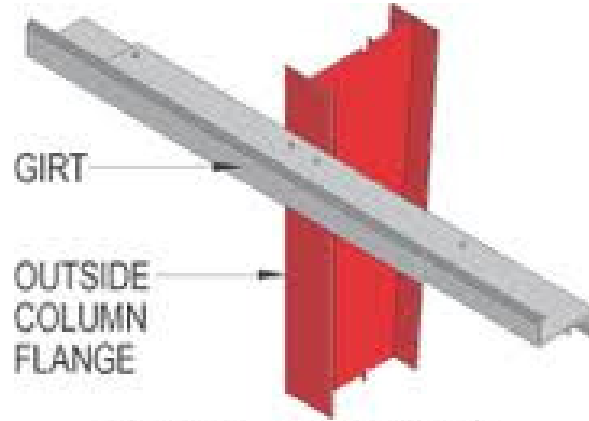

Source: Zamil Steel

Miscellaneous:

When reviewing shop drawings from a metal building manufacturer it is recommended that the following be checked. End span purlins should be a heavier gauge than an interior member (i.e. maximum positive and negative moments control at the end span for a continuous member). Purlin bracing should be reviewed. In addition, it is recommended that the project specifications and details dictate the minimum bracing requirements prior to bidding. Although bracing requirements have been removed from the AISI (American Institute of Steel & Iron) recommendations as of 1995, as a minimum it is recommended that at least ¼ point bracing be provided or use the following guidelines:

Purlin Gage	Maximum Spacing of Bracing
14	4'-0"
16	5'-0"
18	6'-0"

Drifts of H/60 and H/120 are the typical criteria for metal building systems for lateral loads. It is sometimes recommended that a limiting sway criterion of H/200 and H/400 be used for certain buildings based on a 10-year wind occurrence. AISC Design Guide #3 should be consulted in all cases.

It is recommended that building tie-rods be used for structures with horizontal base shear reactions in the range of 60 kips. It should also be noted that ACI requires mechanical splices not lap splices for such tie-rods. For base shear reactions less than 60 kips, the use of slab reinforcement & distribution hairpin reinforcement at the columns can be used for a more economical foundation solution.

Contact Information:

Designers wishing to learn more about the pre-engineered metal building approach can contact the Metal Building Manufacturers Association (MBMA). Among the materials available through this association is the Low Rise Building Systems Manual. This manual incorporates the results of research undertaken by MBMA, its member companies and other industry groups.

A complete list of the association's various books, brochures and videos, with descriptions of each available item, is available by writing MBMA at 1300 Sumner Avenue, Cleveland, OH 44115; calling (216) 241-7333 or faxing (216) 241-0105. The association's web site address is www.mbma.com.

Sharing an address and telephone number with the MBMA is the Building Systems Institute (BSI), a 15-year old umbrella organization comprised of MBMA, the American Iron and Steel Institute and the Systems Builders Association. BSI produces educational and marketing materials for the metal building industry. The most important of which is a Metal Building Systems, a 232-page book covering, among other things, the origin and growth of the metal building industry, building systems nomenclature, general design principles, energy considerations and lifecycle costing. You can also contact the Systems Builders Association at 1-800-866-NSBA to verify if a manufacturer is certified.

Another source of information about metal buildings is Metal Building Systems Design and Specifications. Written by Alexander Newman and published by McGraw-Hill, the book is available in bookstores or by contacting McGraw-Hill, 11 West 19th Street, New York, NY 10011.

Definitions of Industry Terms:

The following slides include definitions of terms common to the PEMB industry, some of which are illustrated on this slide.

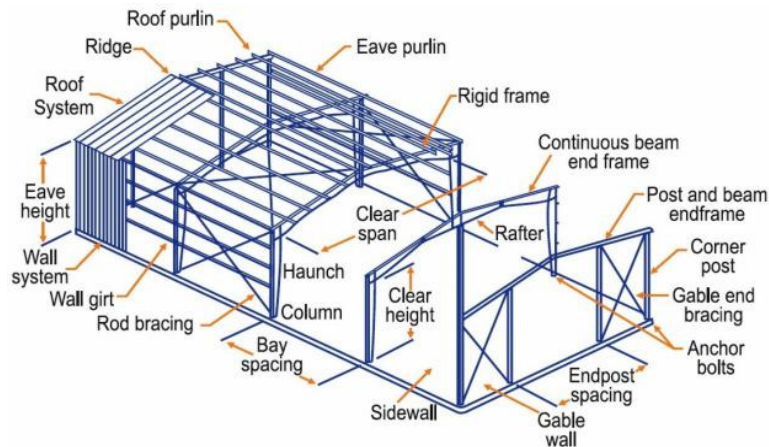

Astragal: A closure between the two leaves of a double swing or double slide door to close the joint.

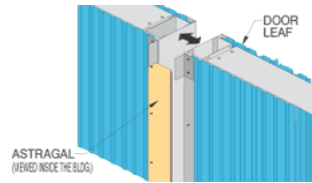

Source: Zamil Steel

Jack or Transfer Beam: A beam used to support another beam or truss and eliminate a column support.

Jack or Transfer Truss: A truss used to support another truss or beam and eliminate a column support.

Jib Crane: A cantilevered boom or horizontal beam with hoist and trolley. This lifting machine may pick-up loads in all or part of a circle around the column to which it is attached.



Source: Construction Machine

Knee: The connecting area of a column and rafter of a structural frame such as a rigid frame.

Knee or Kicker Brace: A diagonal brace designed to resist horizontal loads usually from wind or moving equipment.

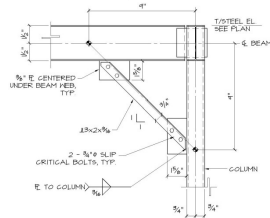

1 TYPICAL KNEE BRACE DETAIL

SCALE: NTS

Portal Frame: A rigid frame structure so designed that it offers rigidity and stability in its plane. It is used to resist longitudinal loads where diagonal bracing is not permitted.



Source: Buck Steel

Post (End Post): A secondary column at the end of a building supporting girts and in a beam-and-column endwall frame, provides additional support to the rafter.

Purlin: A secondary horizontal structural member attached to the primary frame, which transfers the roof loads from the roof covering to the primary members.

Rafter: A primary beam supporting the roof system.

Sag Rod: A tension member used to limit the deflection of a girt or purlin in the direction of the weak axis.

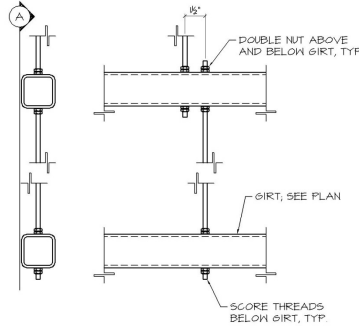

1 TYPICAL SAG ROD DETAIL

SCALE: NTS

Sandwich Panel: A panel assembly used as covering which consists of an insulating core material with inner and outer stress skins.



Source: Maxx Architectural Sheet Metal

Secondary Members: Members, which carry loads to the primary members. In metal building systems, this term includes purlins, girts, struts, diagonal bracing, wind bents, flange, and knee braces, headers, jambs, sag members, and other miscellaneous framing.

Tapered Member: A built-up plate member consisting of flanges welded to a variable depth web.