



**PDHonline Course S257 (6 PDH)**

---

# **Sydney Harbor Bridge: The Giant Coat Hanger**

*Instructor: Jeffrey Syken*

**2020**

**PDH Online | PDH Center**

5272 Meadow Estates Drive  
Fairfax, VA 22030-6658  
Phone: 703-988-0088  
[www.PDHonline.com](http://www.PDHonline.com)

An Approved Continuing Education Provider



## **Sydney Harbor Bridge:** *The Giant Coat Hanger*



# Table of Contents

<b><u>Slide/s</u></b>	<b><u>Part</u></b>	<b><u>Title/Description</u></b>
<b>1</b>	<b>N/A</b>	<b>Title</b>
<b>2</b>	<b>N/A</b>	<b>Table of Contents</b>
<b>3~34</b>	<b>1</b>	<b>Down Under</b>
<b>35~54</b>	<b>2</b>	<b>Origins of an Idea</b>
<b>55~116</b>	<b>3</b>	<b>The Best That Engineering Skill Can Devise</b>
<b>117~143</b>	<b>4</b>	<b>All According to Plan</b>
<b>144~251</b>	<b>5</b>	<b>First Things First</b>
<b>252~362</b>	<b>6</b>	<b>The Coat Hanger</b>
<b>363~400</b>	<b>7</b>	<b>A Great Avenue</b>

# Part 1

# Down Under



*“To get on in Australia, you must make two observations. Say, ‘You have the most beautiful bridge in the world’ and, ‘They tell me, you trounced England again in the cricket.’ The first statement will be a lie. Sydney Bridge is big, utilitarian and the symbol for Australia, like the Statue of Liberty or the Eiffel Tower. But it is very ugly.*

*No Australian will admit this”*

**James Michener, Author**

**RE: excerpt from his 1951 book: *Return to Paradise***

1788--1938

# 150 YEARS OF PROGRESS



**AUSTRALIA**  
**CELEBRATES**

JANUARY 26... APRIL 25 1938

*“Symbol not only for the city,  
but for the aspirations of the  
nation”*



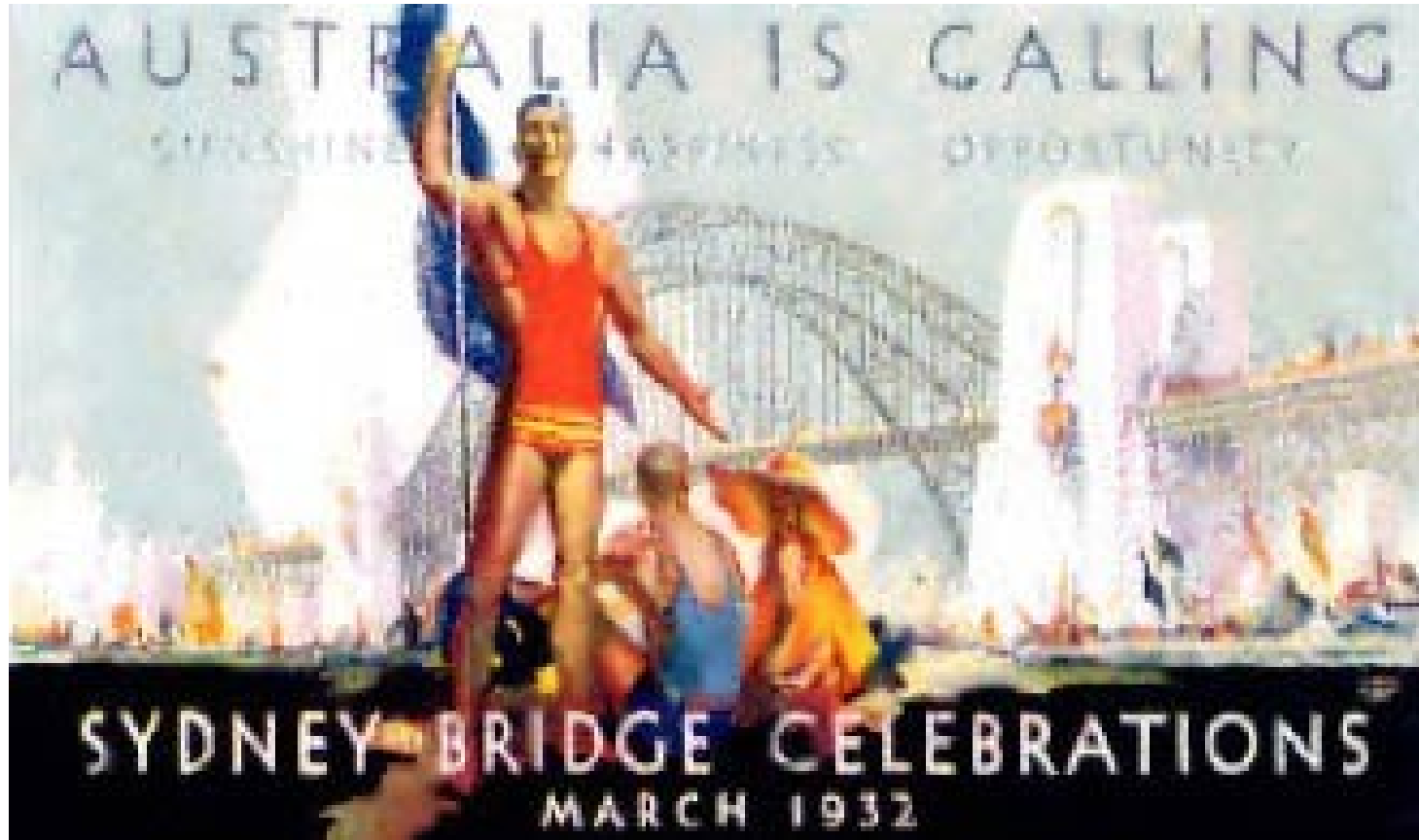



# NEW SOUTH WALES

www.PDHcenter.com

**B**IG AS TEXAS AND VIRGINIA combined, Australia's oldest state leads the nation in population, industry, agriculture, and volume of shipping.



Capt. James Cook discovered and named New South Wales in 1770, claiming it as a British possession. But not until 1788 did the first settlers arrive to lay the foundations of Sydney, now the largest city on the continent. The state's varied landscape includes Australia's highest mountains, magnificent beaches, tall timber, and sweeping plains.

**AREA:** 309,433 sq. mi.; fourth largest state. **POPULATION:** 4,193,000; majority of British stock; remainder mostly continental European; 6 of every 7 people live in urban districts. **ECONOMY:** Min-

ing coal, silver-lead-zinc; steelmaking; manufacturing; agriculture. **MAJOR CITIES:** Sydney (pop. 2,300,000), capital, principal port; Newcastle (pop. 220,000), steel, port; Wollongong and Port Kembla (combined pop. 146,000), coal, steel.

www.PDHonline.org

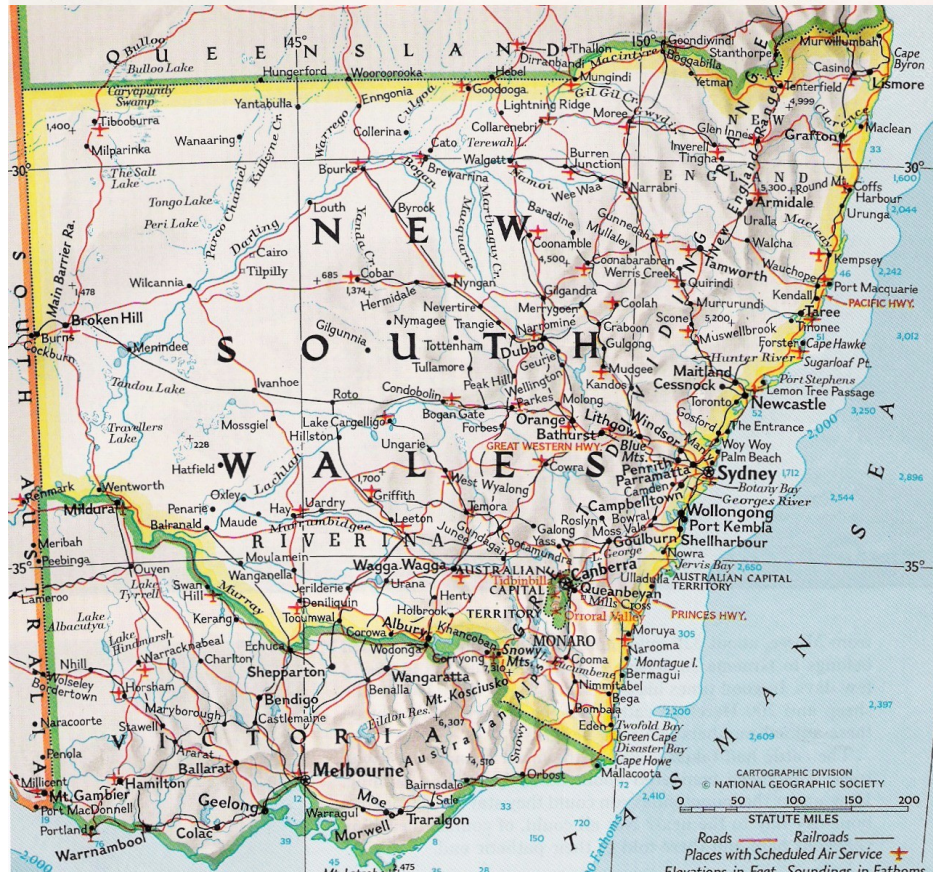

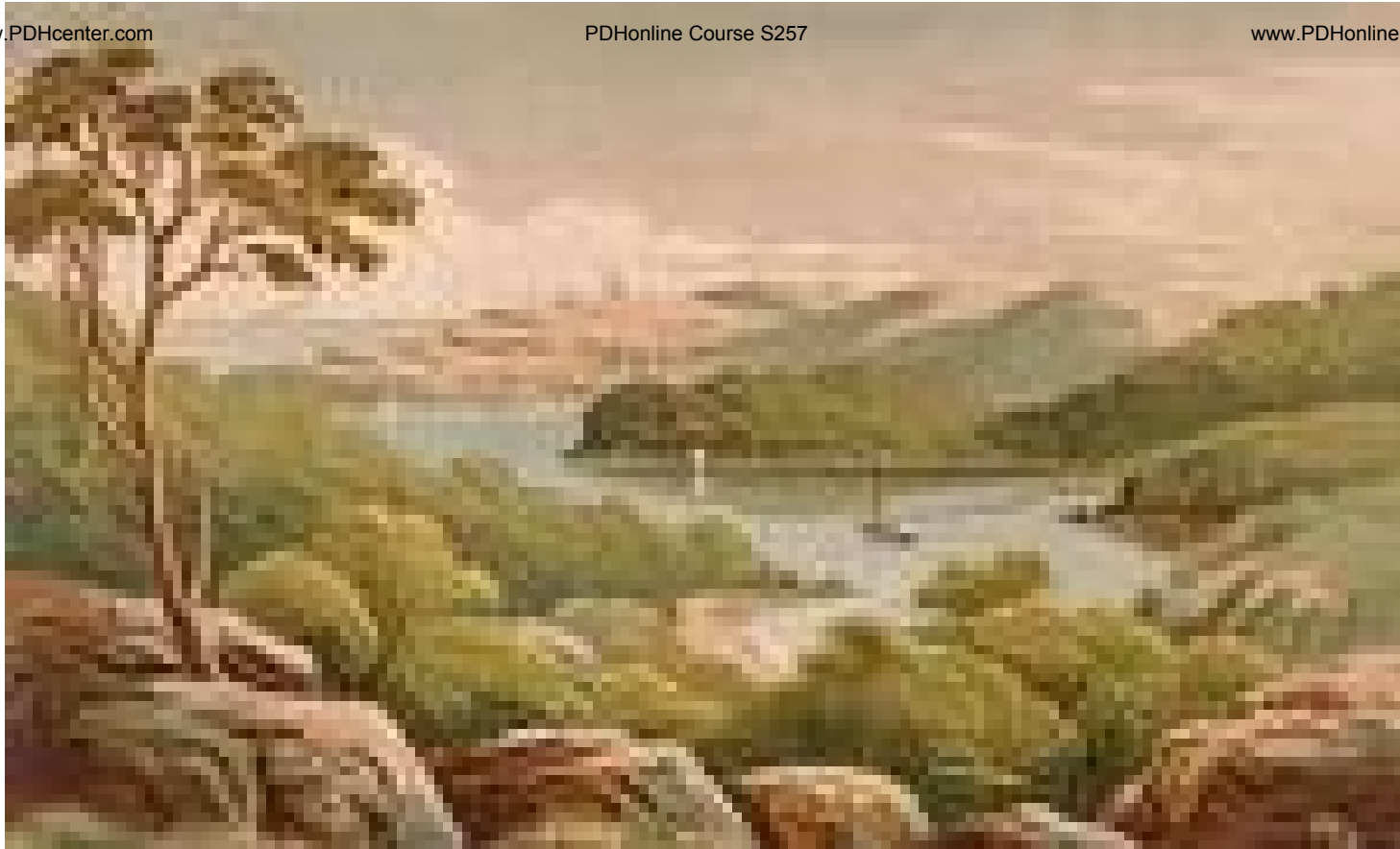

***“There the proud arch Colossus like bestride yon  
glittering streams and bound the strafing tide”***

**Poem: *Visit of Hope to Sydney Cove, near Botany Bay (1789)*  
by Erasmus Darwin (the Grandfather of Charles Darwin)**



*“The wonderful sheet of water lying inside Sydney Heads, Australia, has every requisite that a first-class harbour ought to have. It is easy of access and free from sunken dangers. It is large – big enough to accommodate the combined navies of the world – yet its shape - a number of inlets all branching away from a central channel – gives perfect shelter from all the winds that blow. In addition its waters are uniformly deep, its shores steep and the holding ground excellent...Its natural and overwhelming advantages induced Governor Philip, sent out from England to form a settlement at Botany Bay, to remove on January 26, 1788, to a new site in one of the harbour’s many inlets. He christened this ‘Sydney Cove,’ after Thomas Townshend, first Viscount Sydney, who was then Secretary of State for the Colonies...”*

RE: excerpt from an article appearing in *Wonders of World Engineering*, 1938

*SKETCH*  
**SYDNEY COVE, PORT JACKSON,**  
*in the*  
**COUNTY of CUMBERLAND,**  
*in the*  
**NEW SOUTH WALES**  
*July 1788*

*Scale of Feet to an Inch*  
 1 2 3 4 5 6 7 8 9 10 11 12 13 14 15 16 17 18 19 20 21 22 23 24 25 26 27 28 29 30 31 32 33 34 35 36 37 38 39 40 41 42 43 44 45 46 47 48 49 50 51 52 53 54 55 56 57 58 59 60 61 62 63 64 65 66 67 68 69 70 71 72 73 74 75 76 77 78 79 80 81 82 83 84 85 86 87 88 89 90 91 92 93 94 95 96 97 98 99 100

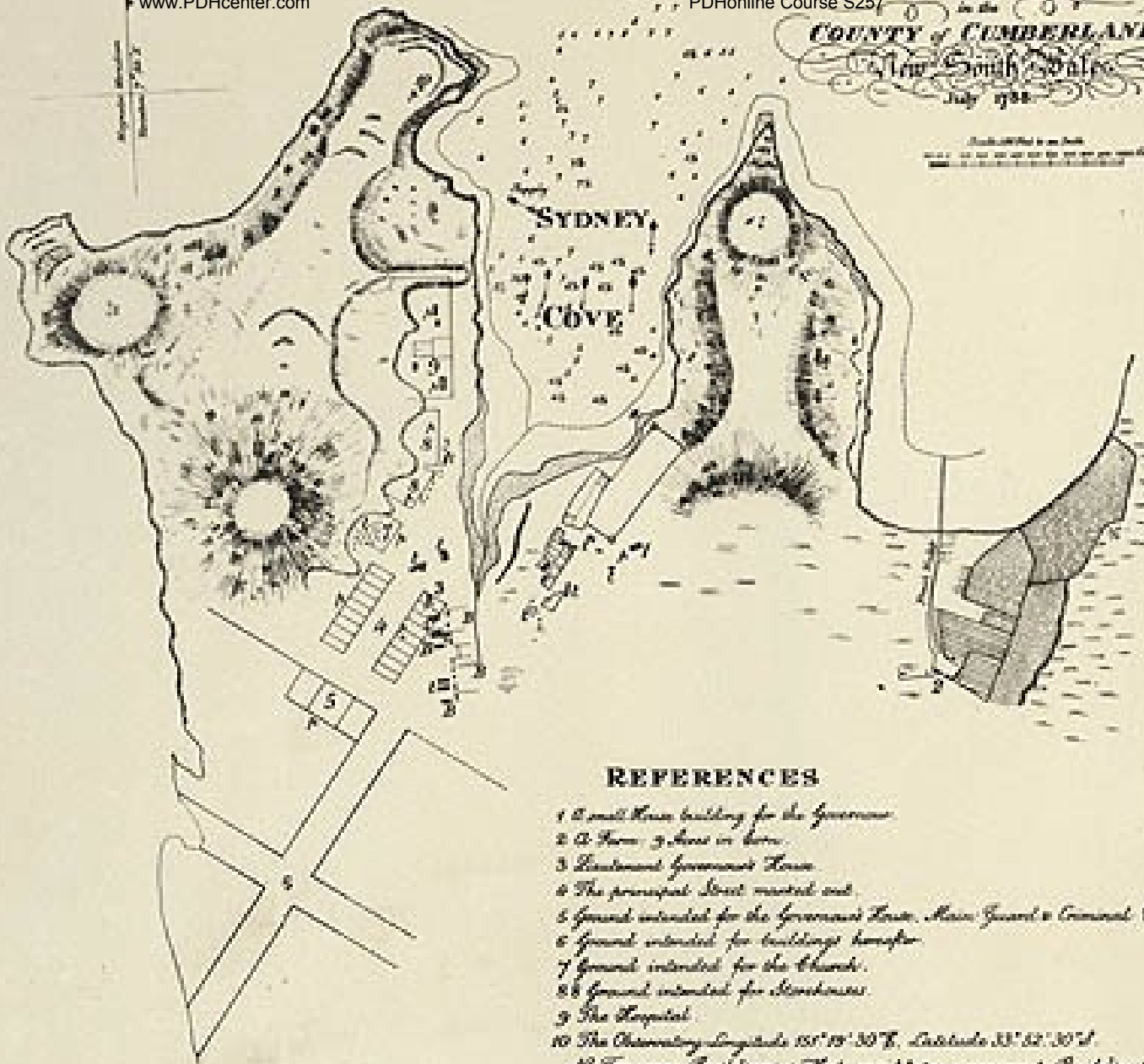

**REFERENCES**

- 1 A small House building for the Governor
  - 2 A Farm 3 Area in between
  - 3 Lieutenant Governor's House
  - 4 The principal Street marked out
  - 5 Ground intended for the Governor's House, Main Guard & Criminal Court
  - 6 Ground intended for buildings hereafter
  - 7 Ground intended for the Church
  - 8 Ground intended for Storehouses
  - 9 The Hospital
  - 10 The Observatory Longitude 151° 15' 30" E, Latitude 33° 52' 30" S
- All Temporary Buildings & Halls are H. H. H. permanent Buildings proposed, or now erecting are p. p. H. H. H. H. Temporary Buildings*

**Map of Sydney  
 Cove (Port  
 Jackson)  
 July 1788**

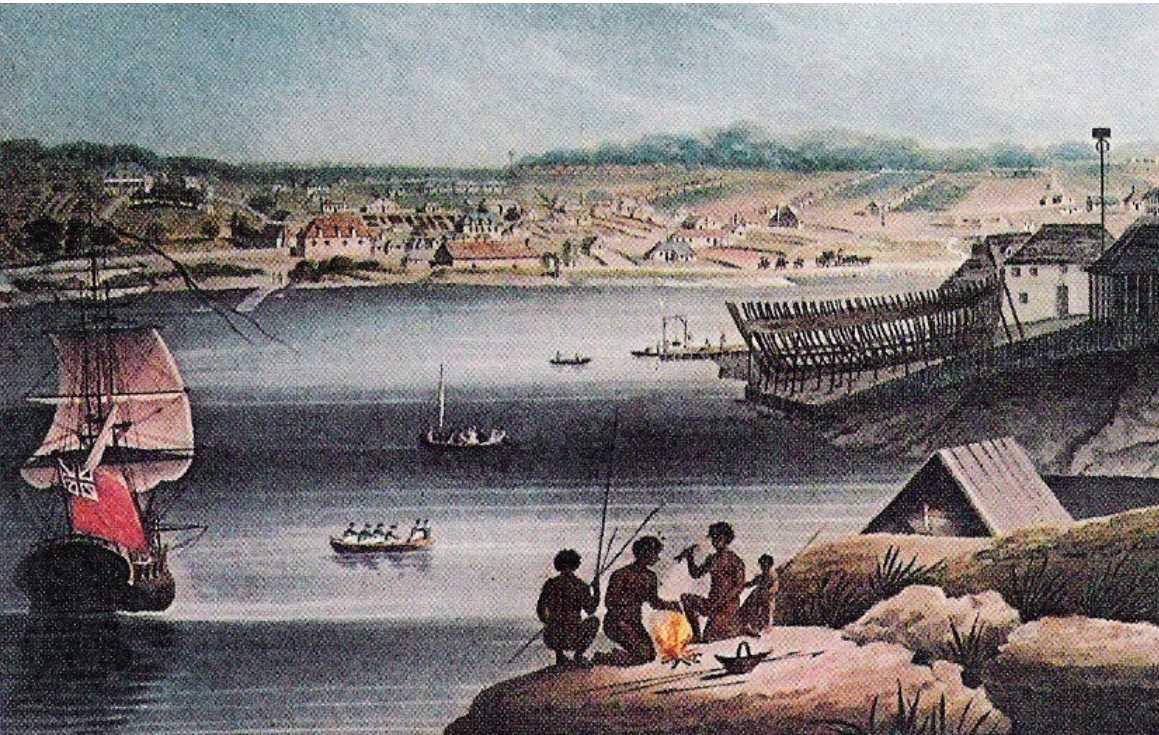

## **Sydney Harbor ca. 1804**





*“...The century and a half which have elapsed since Philip first hoisted the Union Jack there has seen his tiny settlement grow into a city of well over a million inhabitants. This rapid growth, in recent years, has been directly responsible for spanning the main channel of Sydney’s magnificent harbour, from north to south, with a miracle of modern engineering – Sydney Harbour Bridge...”*

*Wonders of World Engineering,  
1938*





**Note: *Sydney Opera House* (Bennelong Point) under construction  
(ca. 1966)**



*“...you can see it from every corner of the city, creeping into frame from the oddest angles, like an uncle who wants to get into every snapshot. From a distance it has a kind of gallant restraint, majestic but not assertive, but up close it’s all might...”*

**Bill Bryson, Author**







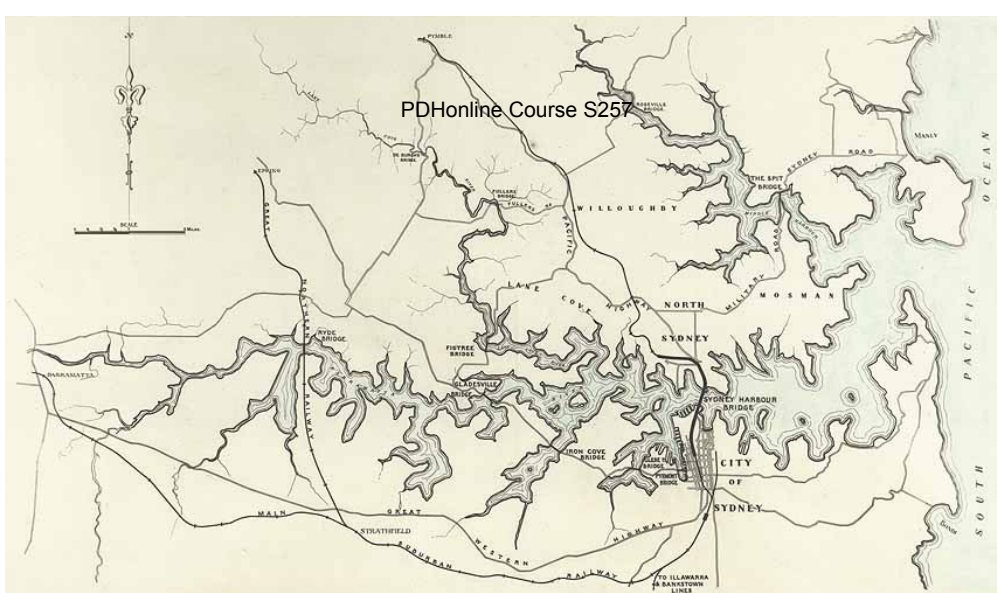

*“...From the Heads at its entrance, facing eastward into the Pacific Ocean, the main channel runs inland, first south-westward and then westward, for some thirteen miles. The original settlement, forming the nucleus of modern Sydney, was on the South shore, about five miles from the entrance – and here the distance to the north shore is only about 600 yards. The harbour is so extensively indented, however, that although its area is only 22 square miles, its shore line is more than 180 miles long. Thus rapid communication with the north shore – which offers many advantages as a residential neighbourhood – is impracticable by land...”*



**Bird's Eye View  
Map (ca. 1921)  
North Sydney pop.  
300K & South  
Sydney pop. 600K.  
Two proposed  
bridges indicated.  
Suspension bridge  
(below) and Arch  
bridge (above)  
between Milsons  
Point (right),  
North Sydney and  
Dawes Point (left),  
South Sydney**



*“...Until recent years,, therefore, communication was effected by ferry-boats, plying to and fro busily and carrying as many as 40,000,000 passengers a year. As in the parallel instance of New York and its neighbour Brooklyn, the necessity for a connecting bridge (or, alternatively, a subway) between Sydney proper and North Sydney, across the harbour, became greater every year...”*

*Wonders of World Engineering, 1938*



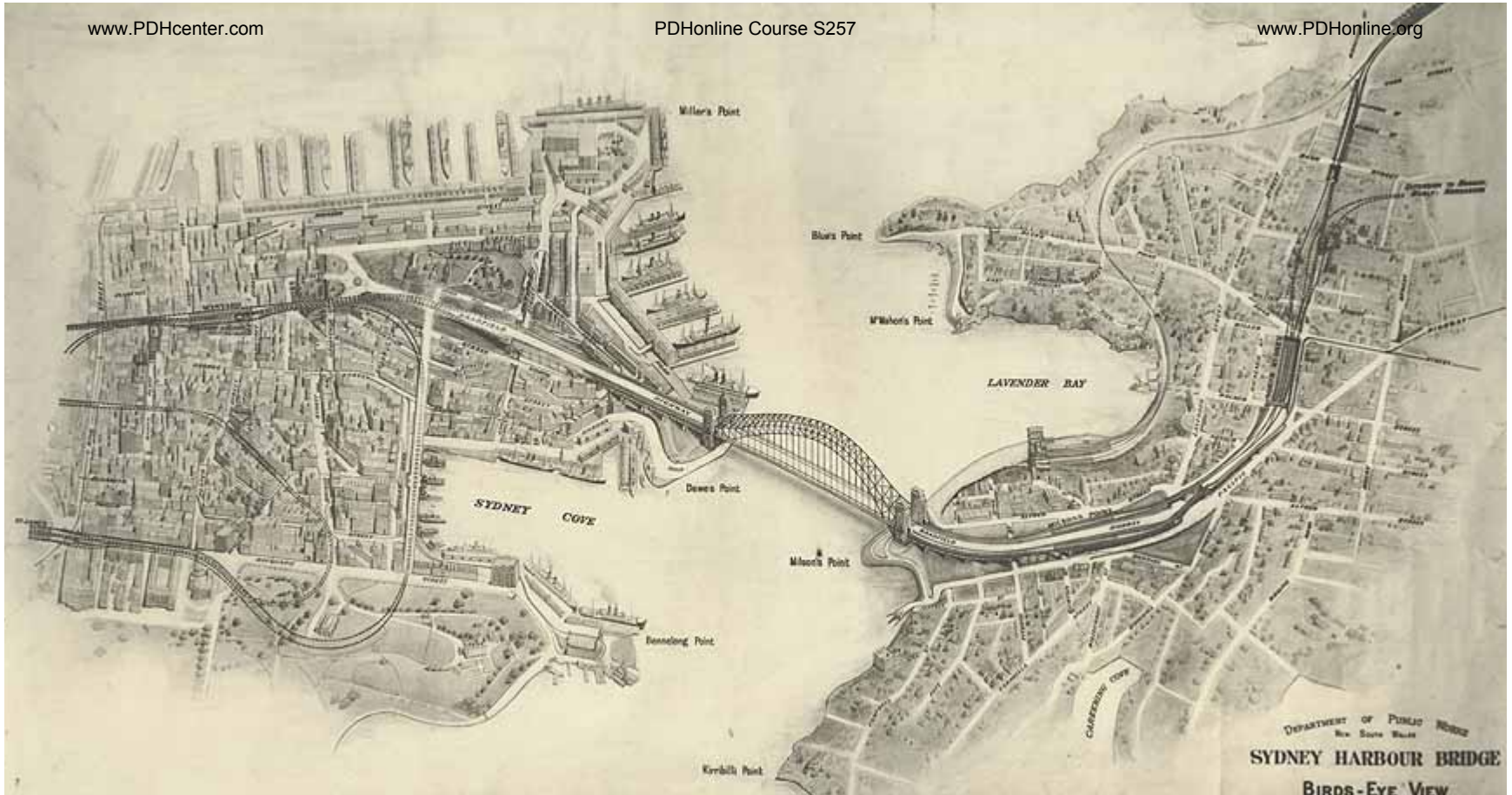

**Bird's Eye View Map (ca. 1922)  
Proposed Sydney Harbour Bridge  
Connecting Dawes (left) and Milsons (right) Point/s  
(Between Sydney Cove and Lavender Bay)**

**By necessity, ferries were long part of the transportation matrix that served both shores of Sydney. By 1904, ferries carried 19 million passengers annually. By 1927 – the peak year of ferry service, 47 million passengers were served. Prior to the Sydney Harbor Bridge, two steam ferry services operated, both originally conveying horse-drawn vehicles and later automobiles. Milsons point (North Sydney) served as the ferry-train-tram interchange up until the opening of the Harbor bridge in 1932. That same year, ferry passenger traffic fell to 20 million per year. In 1924 (to allow for construction of the bridge abutment), the Milsons Point Station and wharf were relocated to adjoining Lavender Bay.**



**Milsons Point Ferry Terminal (ca. 1922)**

# **The Bradfield Scheme**

***John Job Crew (JJC) Bradfield*** was the child of working class English immigrants to Australia (he was the ninth of ten children). A native “Sydney sider,” he was proficient in mathematics and obtained a degree in civil engineering from the *University of Sydney*. In 1891, he joined the *New South Wales Dept. of Public Works* (as a draftsman). He worked on several major projects and was promoted to assistant engineer. At the turn of the century, he became intimately involved with initiatives to provide Sydney with a modern, up-to-date public transportation system. In particular, this included electrified railways and a bridge that would cross Sydney Harbor in the vicinity of the business district. In 1911, the NSW government announced a commitment to bridge Sydney Harbor and in 1913, Bradfield was appointed *Chief Engineer for Metropolitan Railway Construction and Sydney Harbour Bridge*. In 1914, he was sent on a fact-finding mission to Europe and the United States and returned at the outbreak of WWI (August 1914). In 1915, *Report on the Proposed Electric Railways for the City of Sydney* (authored by Bradfield) was produced and published in 1916.





## Harbor Crossing Schemes (ca. 1911)

# Dr. John Job Crew Bradfield

## “Father of the Bridge”

(1867-1943)

As Chief Engineer of the Sydney Harbor Bridge, Bradfield’s role is often misunderstood. Though the *general* design was his, the *detail design* of the bridge was by Ralph Freeman (consulting engineer to *Dorman, Long & Co.* – the bridge contractor). Bradfield and Freeman both made claims as the designer of SHB thus, they were at odds with one another. In 1924, Bradfield received a doctorate in engineering from his alma mater. He retired from public service in 1932 and, with his son; K.N.E. Bradfield, set-up an engineering consultancy. He died in 1943.

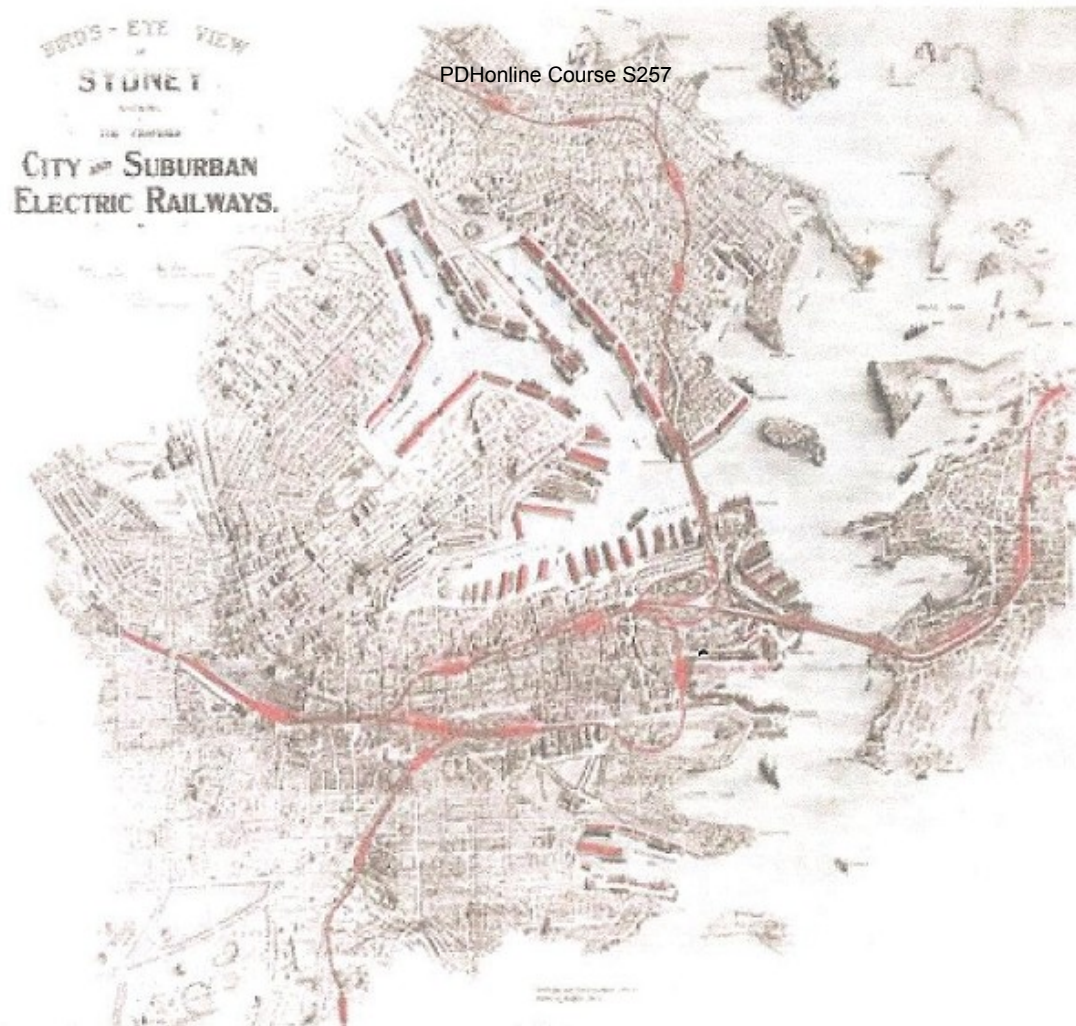

***“Bird’s Eye View of Sydney Showing the Proposed City and Suburban Electric Railways”***

**(excerpt from Bradfield’s 1924 doctoral thesis which was based on his 1915 report)**

# Sir Ralph Freeman (1880-1950)

Ralph Freeman is the unsung hero of Sydney Harbor Bridge. His (along with associate G.C. Imbault) precisely detailed design for SHB ensured its success. In 1901, he joined the prestigious London engineering consultancy; *Sir Douglas Fox & Partners* (later *Freeman, Fox & Partners*). He designed several bridges in South Africa and armament factories in England during WWII. In 1947, he was Knighted for his lifetime of service to the crown. He died in 1950.





*“Bradfield wanted to be the Napoleon III of Sydney. He wanted to pull down everything in the way of his grandiose schemes. He was always thinking of the future. He was probably the first man to plan for Sydney as a city of two million.”*

**Jack Lang, NSW Premier**

# **John (Jack) Thomas Lang (a.k.a. “The Big Fella”) (1876-1975)**

**As Premier of NSW for two terms (1925-1927 & 1930-1932), Lang’s moral and financial support for Bradfield’s plans were instrumental in building the Harbor Bridge. In his second term, “The Lang Plan” ensured funding for public works projects (including the bridge) providing much needed jobs for very many people. Ultimately, Lang was removed from office over this plan and loans were taken to complete the bridge due to cost overruns.**



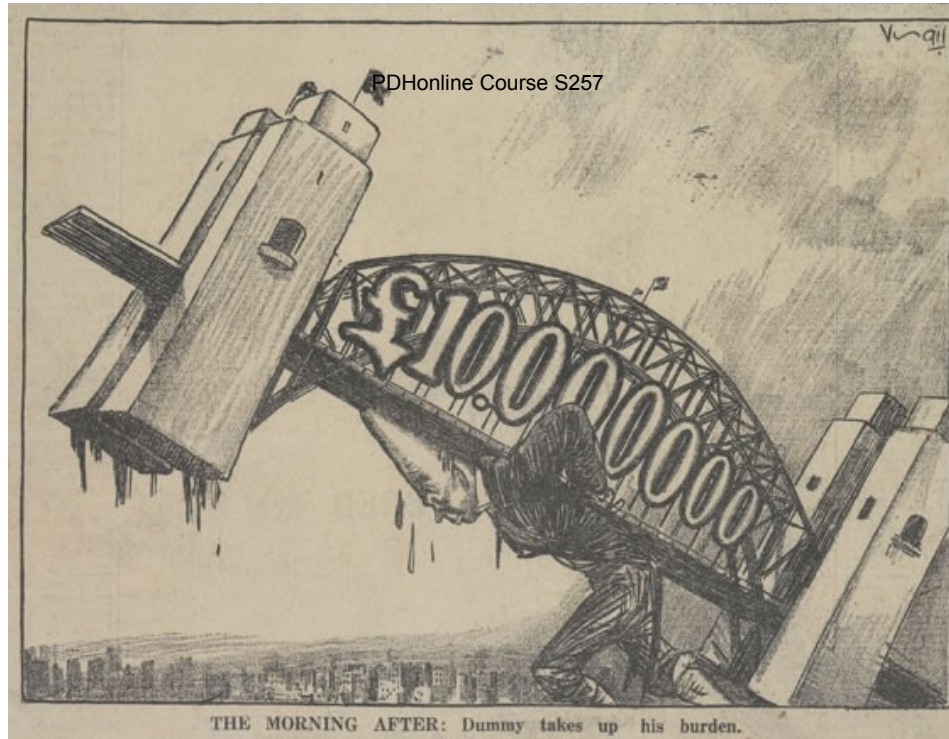

## **Newspaper Cartoon (ca. 1932)**

**Decrying the financial burden to the public caused by the cost overruns of the Sydney Harbor Bridge. In fact, the workmen's families referred to the bridge as "The Iron Lung" because it kept so many families financially afloat during hard times. The bridge would ultimately cost 3x the estimate thus loans were necessary to fund the construction. In 1986, fifty-four years after the bridge opened, the loans were finally paid back in full.**

*“Jack Lang was one of those characters that you could both love and hate at the same time”*

**Gerald Stone, Historian**



***“In spite of the popular endorsement of my assassin’s stroke, I am still wondering if I did right. I still believe that Lang has a great deal of right on his side...”***

**Sir Phillip Game, NSW Governor – July 1932**

**RE: his dismissal (in May, 1932) of Jack Lang, NSW Premier over his controversial funding for public works projects at the height of the great depression. In retrospect, the NSW Governor’s lament over his actions is well founded. Around the world, great public works projects like Sydney Harbor Bridge, Hoover Dam etc. put thousands of people to work at a time when there was no work to be found otherwise and provided much needed infrastructure. Grandiose public make-work projects, delays in construction caused by WWI (1914-1918) and the rise of the motor car/truck to prominence made the period “Between the Wars” (1920-1940) a golden age of bridge construction.**

# Part 2

# Origins of an Idea



**Convicted of forgery, noted English architect *Francis Greenway* (1777-1837) was sent to the penal colony at Botany Bay. There, he served as colonial architect under Governor Lachlan Macquarie. In 1815, he suggested to Governor Macquarie that a bridge be built connecting the opposing shores of Sydney. The proposed low wooden bridge (on piled foundations) was rejected by Macquarie outright since it would have sealed the inner half of the harbor to shipping.**

***“...would give an idea of strength and magnificence that would reflect credit and glory on the colony and the Mother Country”***

**Francis Greenway - Colonial Architect, 1825**

**RE: excerpt from a letter Greenway wrote to *The Australian* newspaper in favor of a bridge for Sydney Harbor**

**Though Francis Greenway's suggestion for a Sydney Harbor Bridge never took root, the idea lived on and in 1840 naval architect Robert Brindley proposed a floating bridge for Sydney. In 1857, engineer Peter Henderson recorded the earliest known design drawing for a Sydney Harbor Bridge. In 1879, a truss bridge was suggested and the following year (1880), a high-level bridge estimated to cost 850K pounds was proposed. Also in 1880, a Royal Commission put forth a recommendation that a bridge and/or tunnel crossing Sydney Harbor be built as soon as was practicable. By the end of the 19<sup>th</sup> century, several designs had been put forward for both bridge and/or tunnel schemes, albeit informally.**

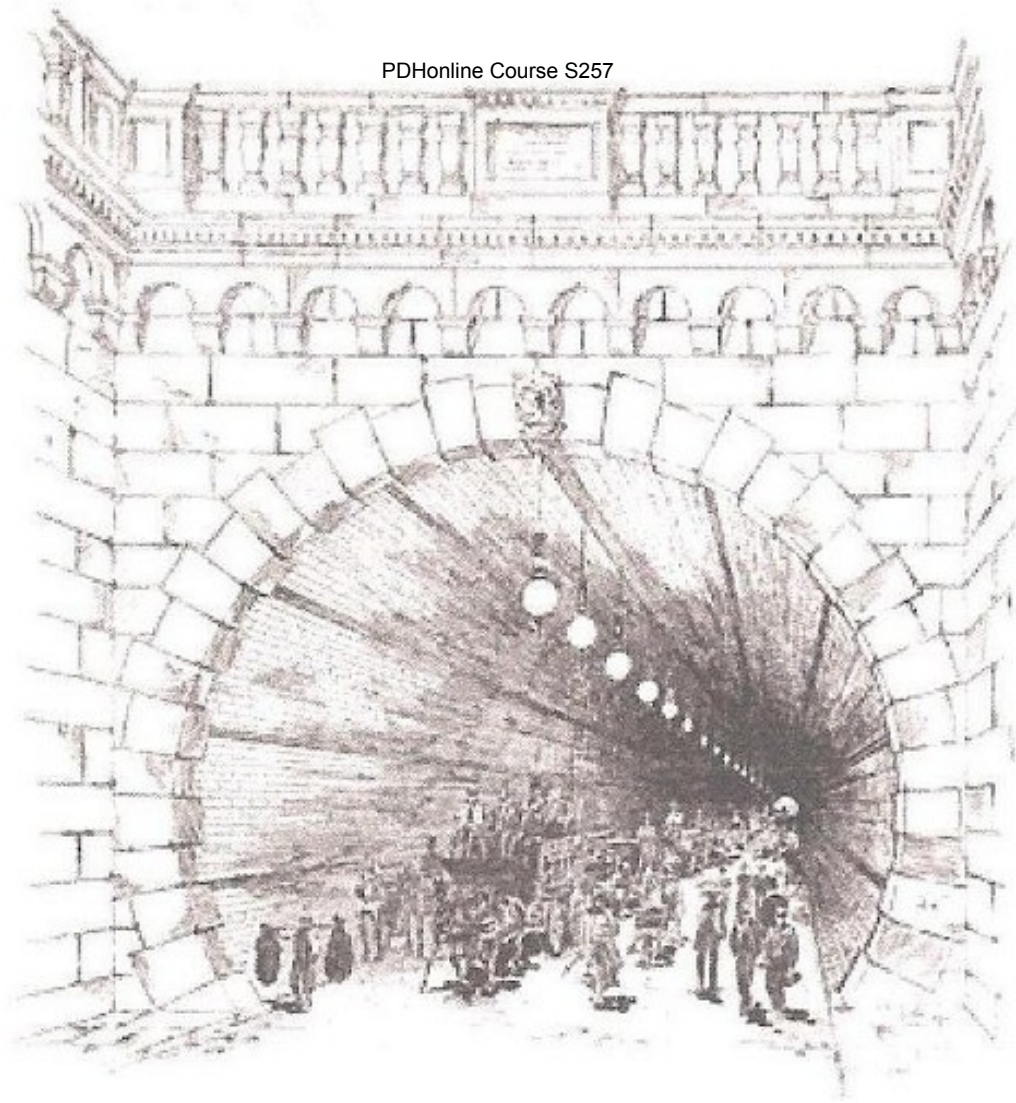

**Proposed North Shore Tunnel**  
*The Sydney Mail* - May 30, 1896

**To begin the new century on the right foot, a new NSW government – seeing the rapidity with which Sydney was expanding, declared an open, world-wide competition soliciting the receipt of designs and tenders (formal proposals) for a bridge spanning Sydney Harbor. The criteria of the competition left the form and/or materials open-ended, but required a single-span road and rail bridge with a water clearance of 55-meters (for 183-meters of its main-span). All entries were anonymous and in September 1900, a total of thirty designs/tenders were received and twenty-four were exhibited in the Queen Victoria Markets in Sydney. Designs included several hybrid designs (i.e. combined arch/suspension bridge), a parabolic truss, a three-hinged arch, a balanced cantilever (w/suspension span) and several suspension bridges.**



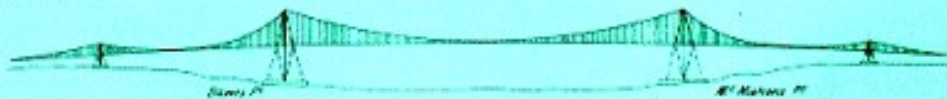
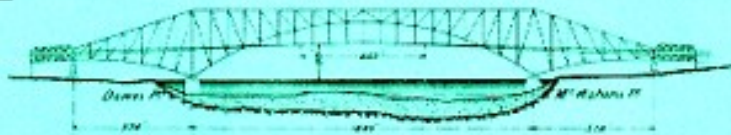
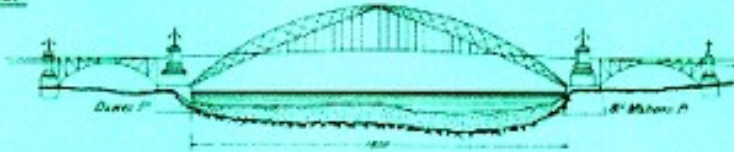
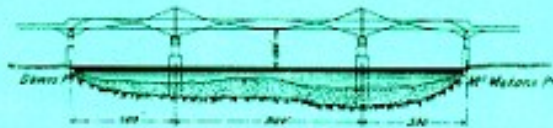
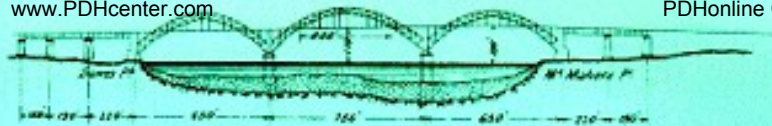

**Some examples of the designs received in the 1900 design competition (all were rejected)**



# **1900 Bridge Design Competition Entry Cantilever Bridge**

Though the *Board of Judges* overseeing the bridge competition ultimately found all tenders to be unworthy of consideration to actually be built, they were however obliged to award prizes to the anonymous competitors. First prize (1,500 pounds) was awarded to the British firm *Sir William Arroll and Company* - designers of the *Firth of Forth Railway Bridge* in Scotland (1890). Second prize (500 pounds) went to the Sydney-based firm *J. Stewart & Company* (designed by Sydney engineer Norman Selfe and Franz Bohny of the German *MAN Company*). The lowest tenderer was the *American Bridge Company*, but when the board began negotiations with them the other tenderers' cried foul and demanded a right to submit revised designs/tenders. The NSW government then intervened by appointing a new board with a mandate to start afresh with a new competition.

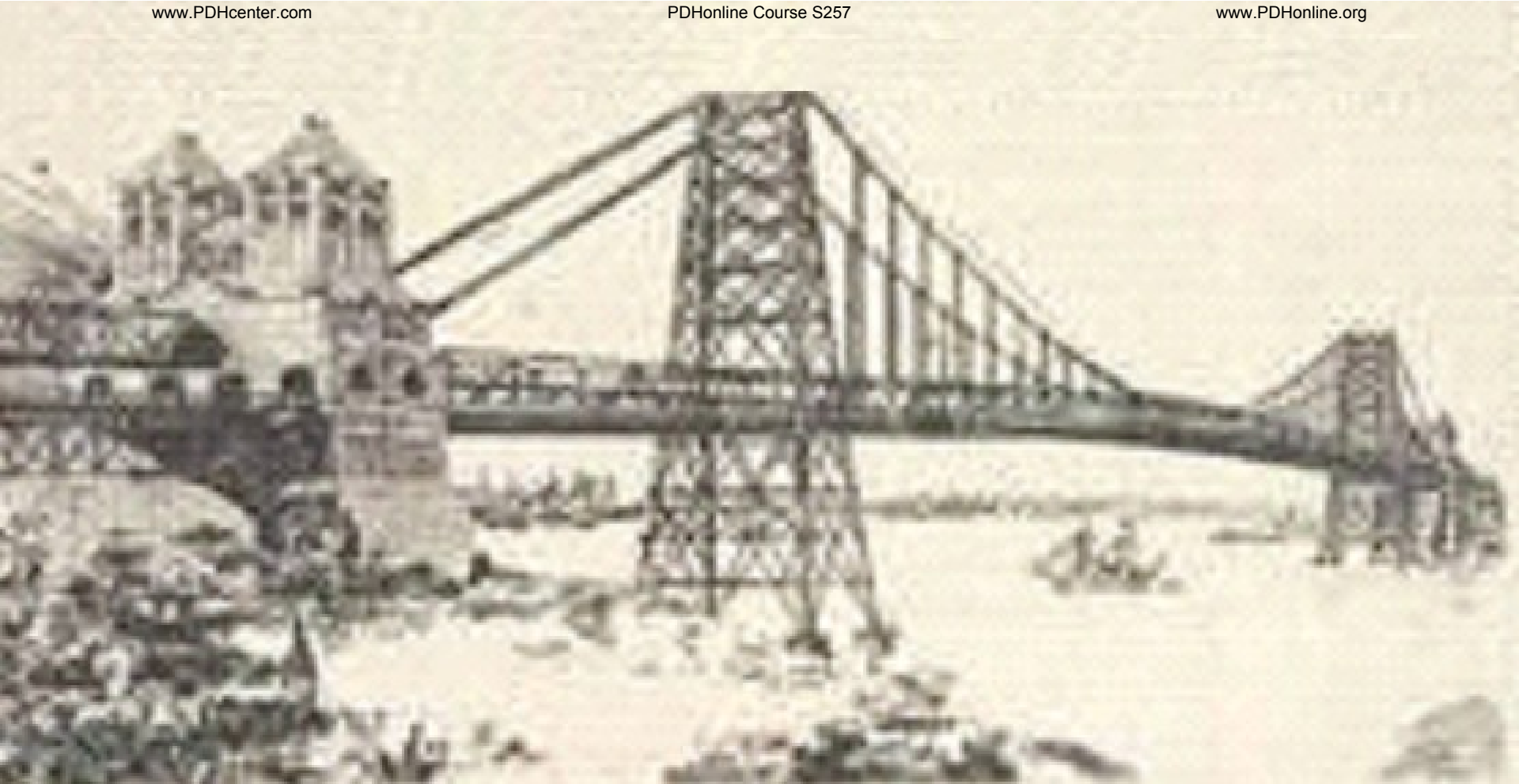

**1900 Bridge Design Competition Entry  
Suspension Bridge  
(Second Prize Winner)**

*“We regret to have to report that owing to the fact that even the best of the designs were unsatisfactory, either as regards cost, structural defects, or other features, we cannot recommend the acceptance of any tender...It is clear that notwithstanding that a design may be practicable and suitable, the question of economy of cost stands in the front rank, because, however beautiful it may be, it cannot be recommended if the cost is prohibitive. On the other hand, cheapness is not everything; a design may be so unsightly that however low its cost, the public would not accept its erection in such a prominent position as the proposed bridge would occupy.”*

**Sydney Harbour Advisory Board – Report on Designs and Tenders  
RE: failure of the 1900 competition to find a suitable bridge design for  
Sydney Harbor**



**Fresh tenders were called for May, 1901. After two extensions, tenders closed in June 1902. This time, design parameters were much more detailed. Gradients, deck arrangement (60-foot wide roadway capable of accommodating tram tracks), foundations, materials etc. were well defined and the entrants were no longer anonymous. The Australian firms of *Gilbert Weaver* and *J. Stewart & Company* submitted a total of six proposals and English firms such as *Cleveland Bridge & Engineering Company* also submitted designs/tenders. A design by Norman Selfe and Franz Bohny (for *J. Stewart & Co.*) of a latticed-truss bridge was selected as the winner. J. Stewart had also submitted ten alternate methods of establishing solid foundations including a freezing process used in sinking mine shafts.**

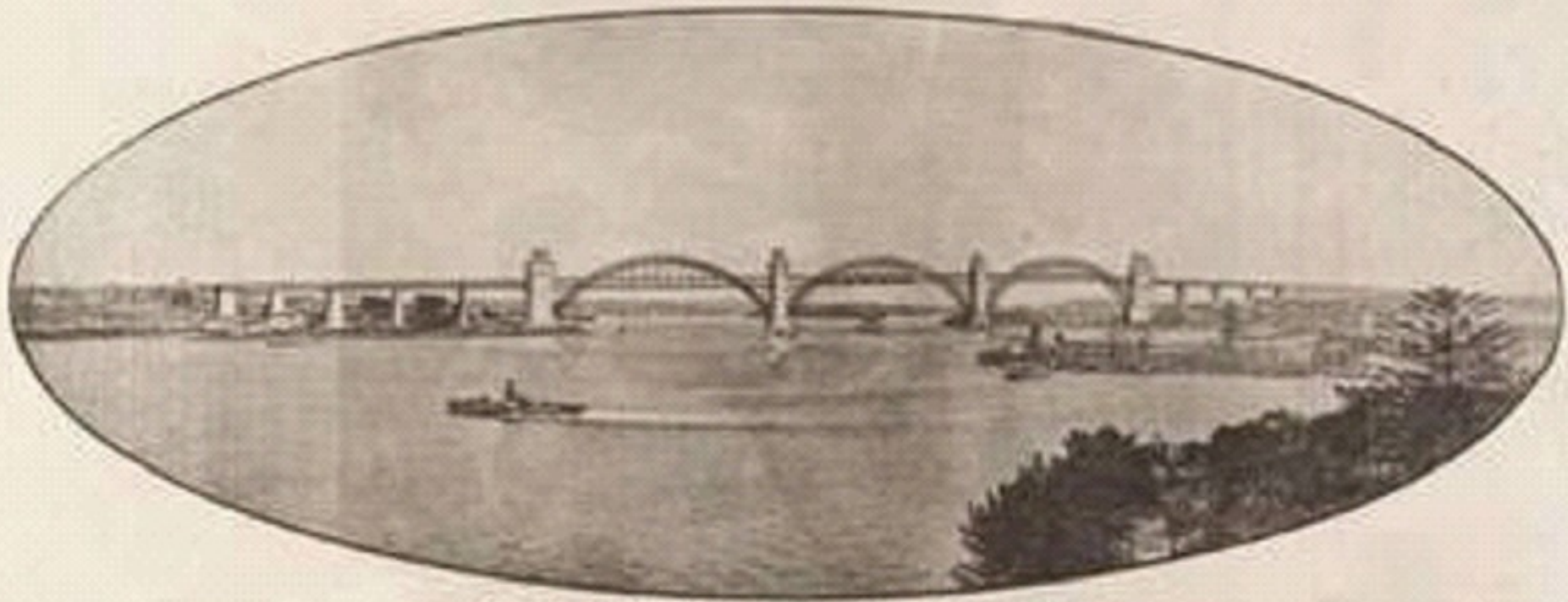

**1902 Bridge Design Competition Entry  
(by Mr. Norman Selfe for *J. Stewart & Co.*)  
Triple-span Arch Bridge**

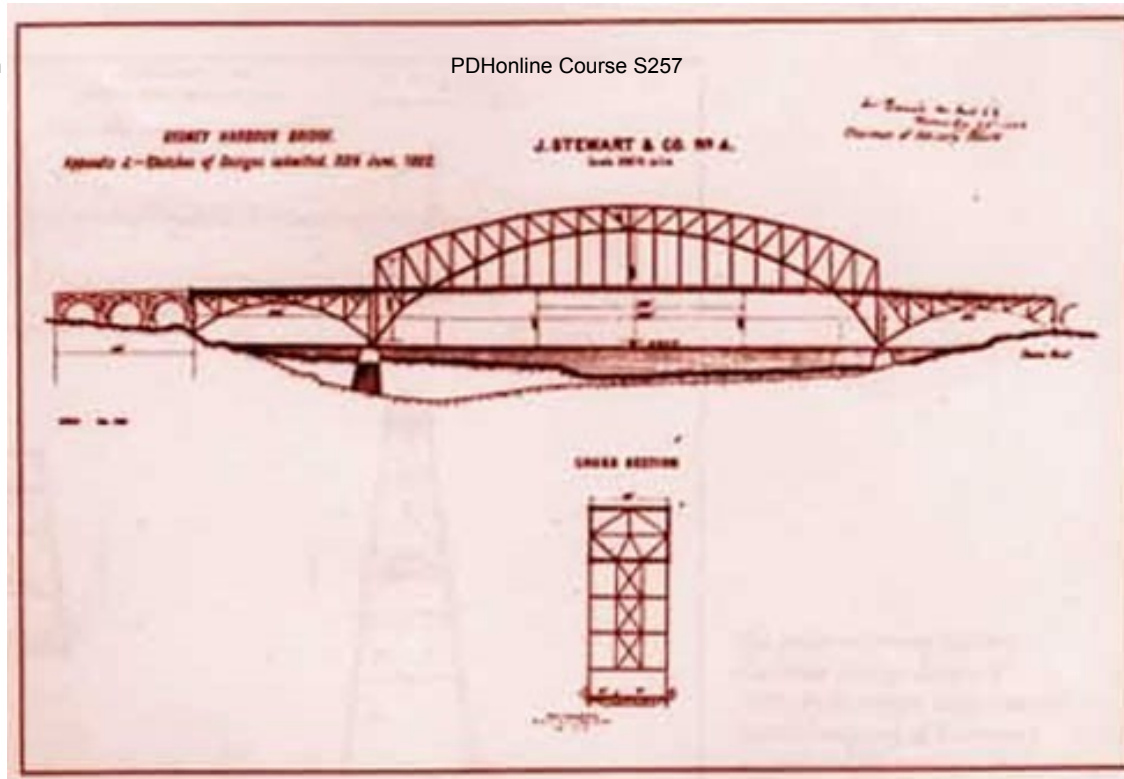

*“The appearance of the bridge is not agreeable, and it would be considered an eyesore if erected, the height of the top of the arch being 420-feet”*

**Board of Judges, 1902**

**RE: rejection of an arch-bridge design (above) by Norman Selfe and Franz Bohny for *J. Stewart & Company* on aesthetic grounds. Ironically, the actual Sydney Harbour Bridge rises to 445-feet.**

LUMP SUM TENDER FOR SYDNEY HARBOUR BRIDGE.

In accordance with the Conditions of Tendering, Departmental Specifications, and General Conditions (I or not), the undersigned, lawfully authorized for the approval of the Minister for Public Works, complete Specifications, Plans, Specifications, Detail Quantities, and Detailed Tender for the proposed Bridge, 2,000 feet long, over Sydney Harbour, and do hereby tender to provide all the material, and transport and erect the same complete in every respect, ability in accordance with the Plans and Specifications referred to by (not or not), and according to the Conditions of Tendering, Departmental Specifications, and General Conditions, which have been inspected by (not or not), for the living term of

years, and to complete the whole of the work within \_\_\_\_\_ weeks from the date of the notification of the acceptance of this Tender; and (I or not) hereby undertake that (I or not) will, within three months from the date of notification of the acceptance of the said Tender, execute and deliver to the Minister for Public Works a valid legal Contract with His Majesty the King, embodying the terms and conditions above mentioned, and to provide the security required by Clause 11 of the General Conditions.

Witness my hand and seal this \_\_\_\_\_ day of \_\_\_\_\_ 1883.

This is the Tender accepted by \_\_\_\_\_ referred to in \_\_\_\_\_ Agreement with His Majesty the King, dated the \_\_\_\_\_ day of \_\_\_\_\_ A.D. 1883.

**Three tenderers' from the second competition were selected and a cantilever design by Norman Selfe and Franz Bohny for *J. Stewart & Co.* was selected as the winner. They further suggested that the bridge project begin post-haste with an anticipated completion in five and one-half years. Before this recommendation could be implemented, the government was defeated with the new NSW government disinterested in such a large expenditure.**

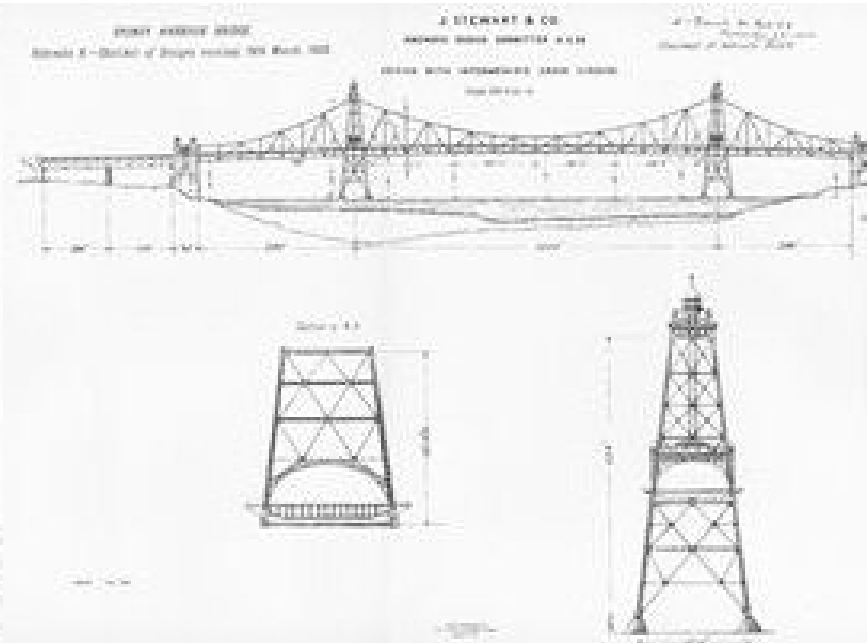
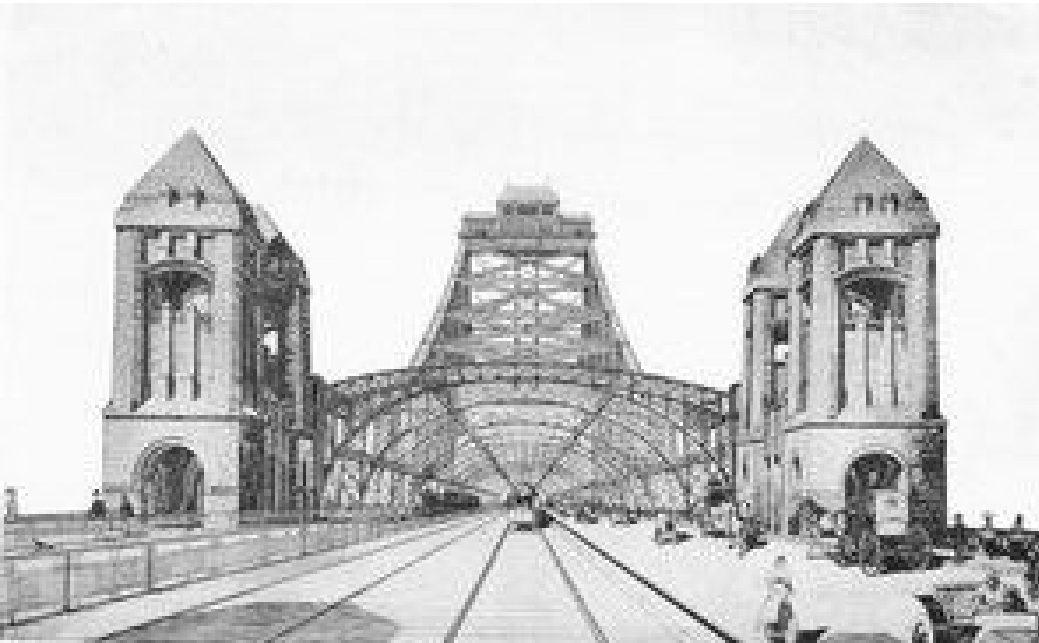

**Cantilever Bridge Proposal  
J. Stewart & Co., 1901  
(winner of the second design competition)**

**A controversy existed over whether a bridge or tunnel should be built thus both schemes were prepared to the exhaustion of a confused and weary *Royal Commission*. In October 1909, Bradfield submitted two proposals for a cantilever design inclusive of four railway lines. In 1910, one of the two cantilever designs was recommended by the *Public Works Committee* (PWC). In the years following, the burning question of connecting and/or extending the main and suburban railway lines on both sides of the harbor was the subject of much study and debate by the PWC. One interim report recommended a trans-harbor subway be built yet - upon further investigation, it found that a bridge across the harbor – though fraught with difficulties and engineering challenges, was preferable.**





***Plan showing the location  
of bridge and tunnel  
proposals submitted to the  
Royal Commission on  
Communication between  
Sydney and North Sydney  
(by H.E.C. Robinson, 1908)***

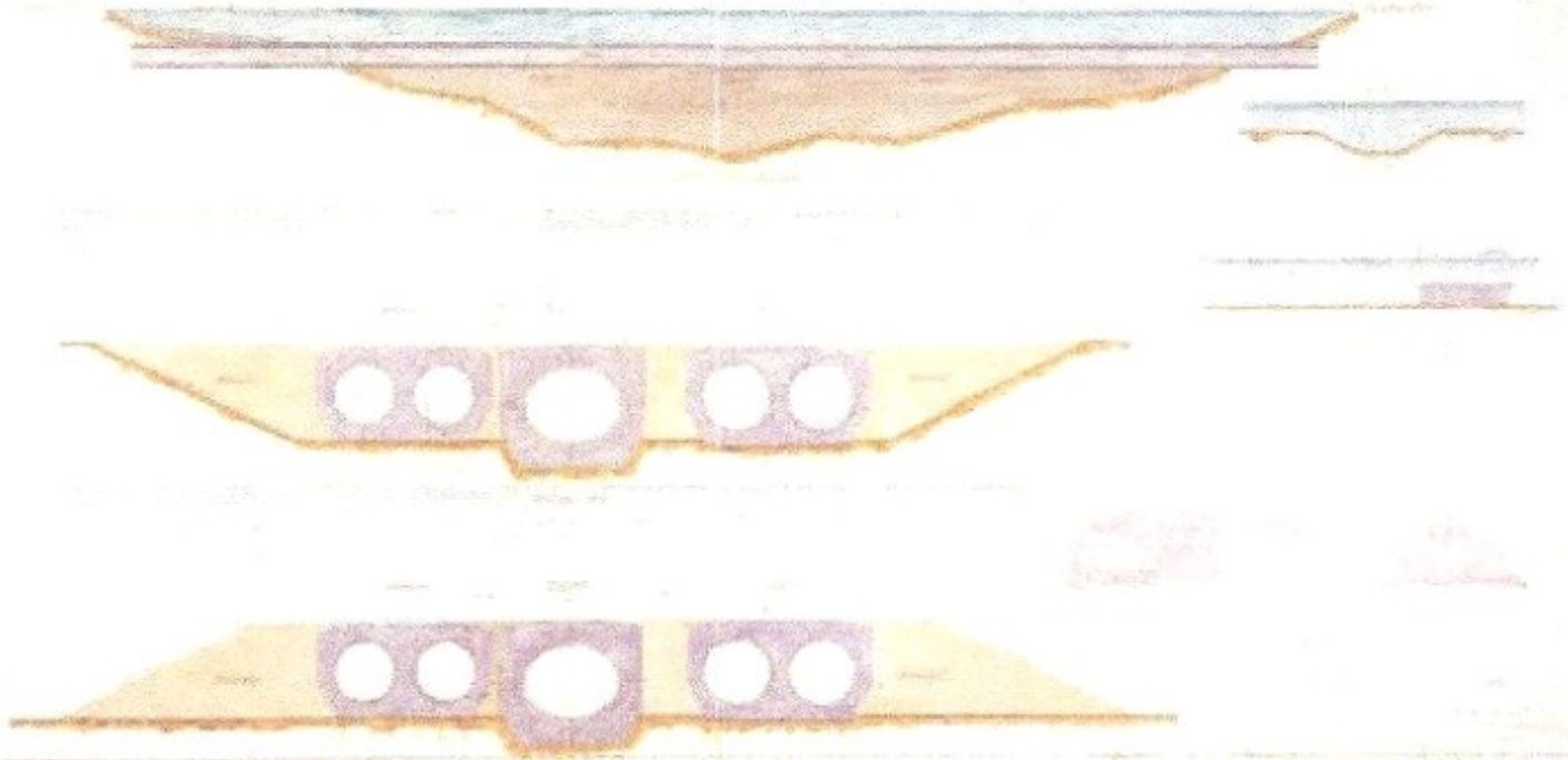

***Proposed subaqueous tubes from Dawes Point to Milsons Point on Detroit River Principle***

**(by H.H. Dare, 1908)**

*“...In 1915, a final report by Dr. Bradfield, the Government’s engineer, led to the passing of an Act authorizing the proposed extension and coordination of the railway systems and as a corollary, the building of a high-level rail and road bridge across Sydney Harbour from Milsons Point to Dawes Point – immediately to the westward of Sydney Cove. In January 1923 the New South Wales Government invited tenders for the building of such a bridge, stipulating that these must conform with the general principles governing its position, span, layout and so forth laid down in Dr. Bradfield’s report, but leaving the competing firms a reasonably wide scope for the design  
Wonders of World Engineering, 1938*

# Part 3

# The Best That Engineering Skill Can Devise



***Sydney Harbour Bridge and Circular Quay Railway Station***  
**(with cantilever bridge - from Bradfield's doctoral thesis, 1924)**





www.PDHcenter.com

PDHonline Course S257

www.PDHonline.org

***Sydney Harbor Bridge: Perspective Elevation (above)***  
**by Robert Charles Given Coulter, Architect**  
***(NSW Dept. of Public Works, 1921)***

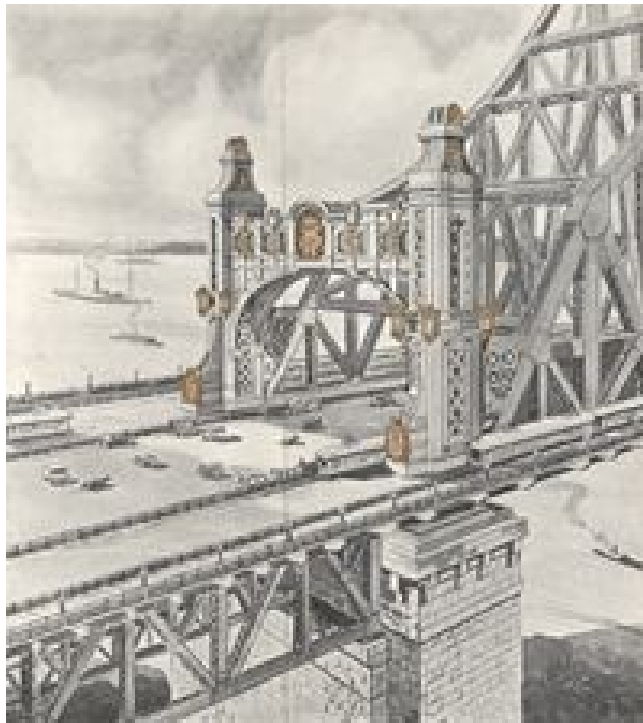





*Sydney Harbour Bridge View  
Showing Southern Approaches*  
by Robert Charles Given Coulter, 1921



**Triple-span proposal by Architect Ernest Stowe, 1922**  
**Central tower (located on *Goat Island*) linking *Balls Head* (Sydney - in foreground) with *Millers Point* (North Sydney – upper left) and *Balmain* (North Sydney – upper right)**

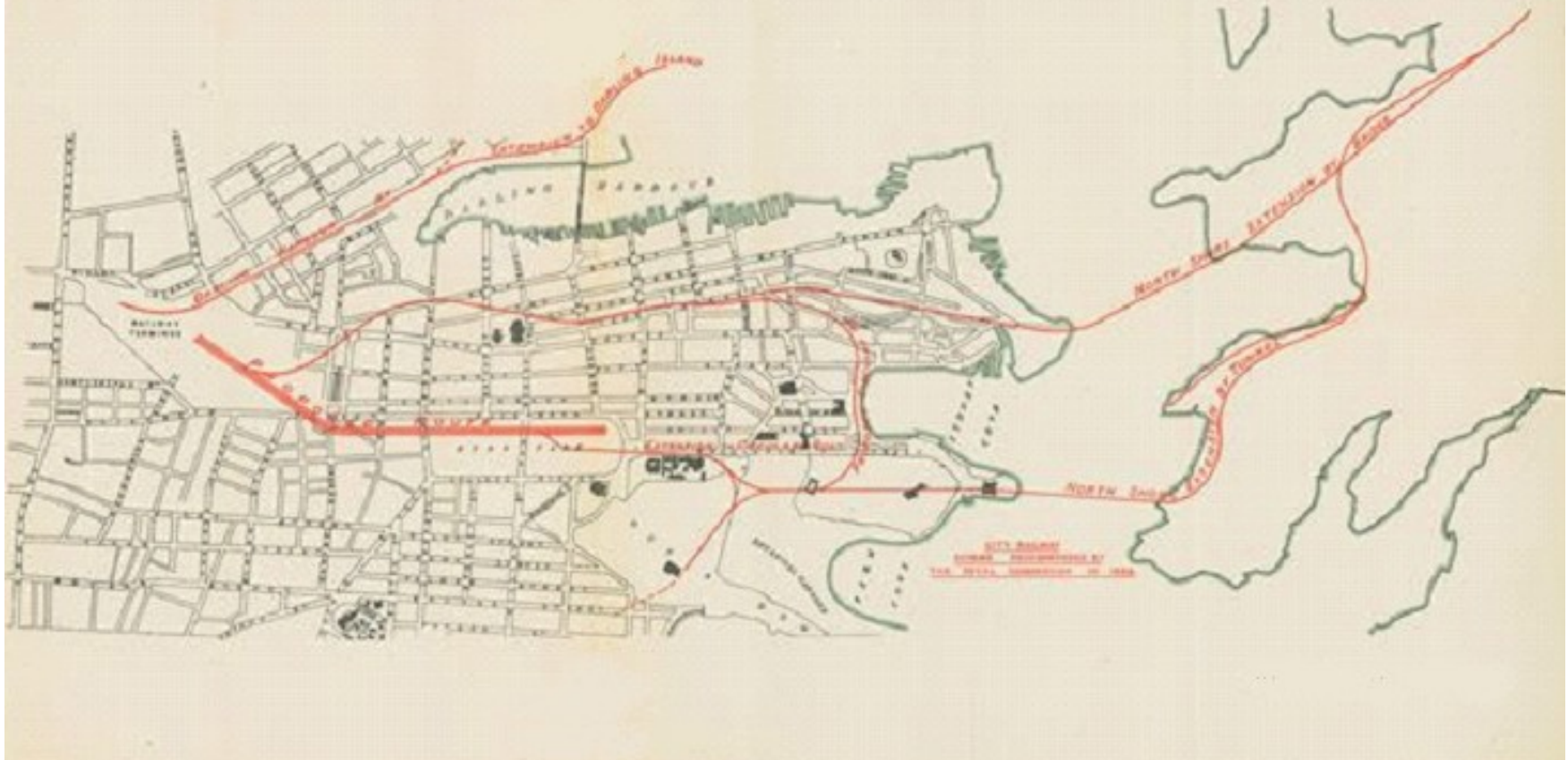

***Map of Sydney and suburbs, 1924. Showing proposed railway lines north (at left) and east (at right)  
(Sydney Department of Lands)***

**Had it not been for the outbreak of the first world war, JJC Bradfield's cantilever design would probably have been built. With the war effort came labor and material shortages and a halt to most construction projects. A general worldwide recession in the aftermath of the war delayed major projects as well. With the boom of the 1920s, conditions steadily improved and in 1922 enabling legislation (*Sydney Harbour Bridge Act*) for the bridge was passed by the nationalist government of Sir George Fuller.**





ANNO TERTIO DECIMO

GEORGI V REGIS.

Act No. 28, 1922.

An Act to sanction the construction of a high-level cantilever or arch bridge across Sydney Harbour by connecting Dawes Point with Milson's Point, together with the necessary approaches, railway connections, and other works connected therewith; to provide for the use of such works by the Constructing Authority and other persons; to provide for the cost of the said works and other expenses connected therewith; to impose a rate on certain lands in relation to such works; to amend the Public Works Act, 1912, and certain other Acts; and for purposes connected therewith. [Assented to, 24th November, 1922.]

**The original 1922 Act called for the building of a cantilever bridge only. While in NYC (in 1914), Bradfield saw the *Hell Gate Bridge* (then under construction). Impressed and realizing an arch would be more suitable for Sydney, he cabled the parliamentary committee requesting that two words be added: "... sanction the construction of high-level cantilever or arch bridge..."**

*“Mr. Lindenthal conceived the bridge as a monumental portal for the steamers which enter New York Harbor from Long Island Sound. He also realized that this bridge, forming a conspicuous object which can be seen from both shores of the river and from almost every elevated point in the city, and will be observed daily by thousands of passengers, should be an impressive structure. The arch, flanked by massive masonry towers, was most favorably adapted to that purpose.”*

Othmar H. Ammann - Assistant Engineer, *Hell Gate Bridge*  
RE: Bradfield had visited the *Quebec Bridge* (a cantilever) but (besides the cost-effectiveness and easier adaptability to rail service) the *braced arch* design of the *Hell Gate Bridge* impressed him most. The *Hell Gate Bridge* is about two-thirds the span of SHB and carries four rail tracks only. Though cantilevers of the day had greater spans, advances in arch design would make the 1,650-foot span of SHB possible.



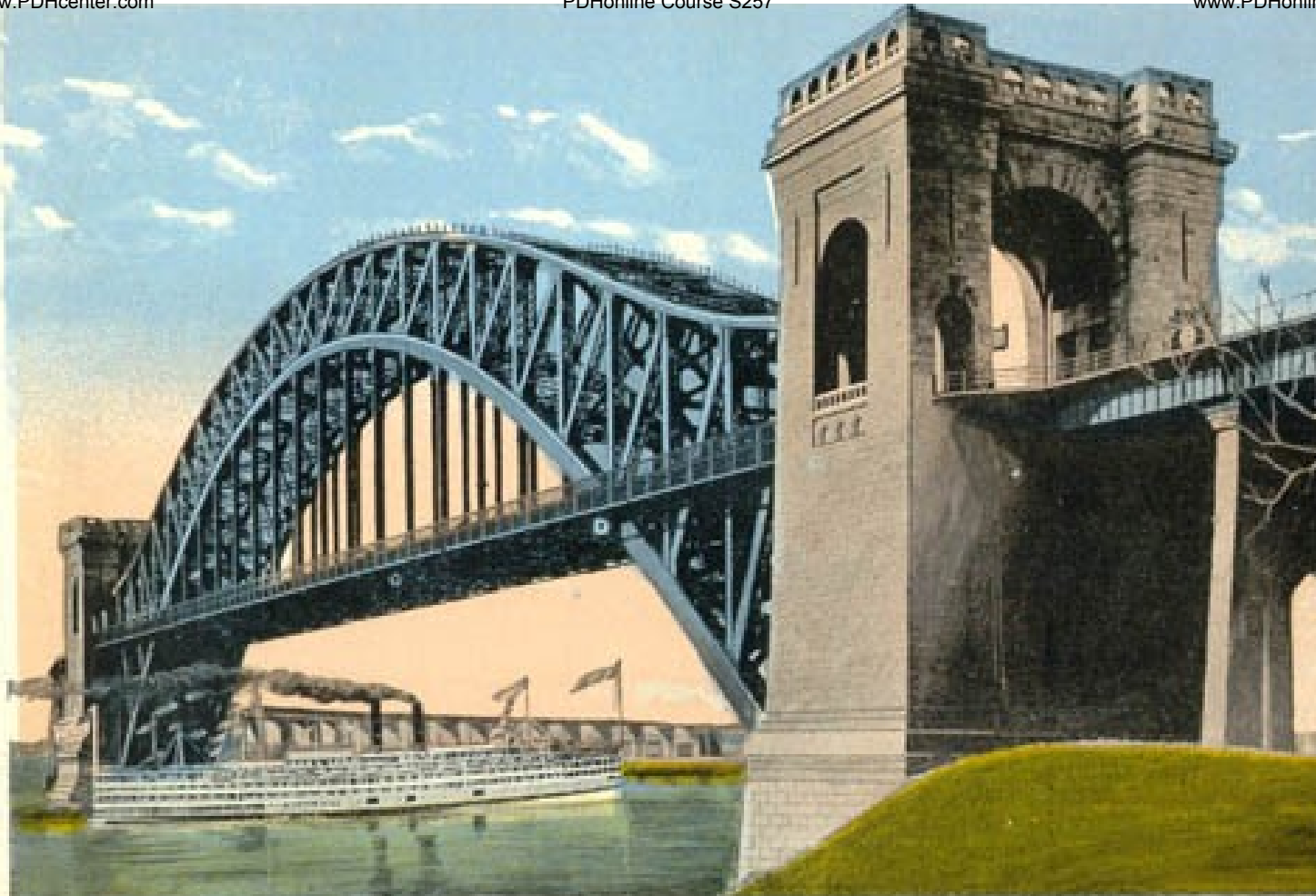

**Hell Gate (Railroad) Bridge (1917)**  
**New York City**  
**(designed by *Gustav Lindenthal*)**



**View of pylon, arch and four RR tracks  
Hell Gate Bridge**

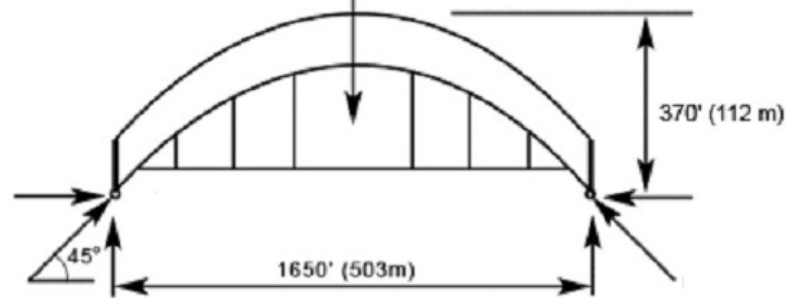

*“...had come to the conclusion that there were no insuperable difficulties to the erection of an arch bridge of the span required, and that an arch bridge would cost 350K pounds less than a cantilever...”*

JJC Bradfield, 1932

**RE:** because a cantilever bridge acts akin to a beam, it relies on its supports (piers) to provide vertical reactions *only* to vertical loads. On the contrary, with an arch bridge vertical loads create both horizontal *and* vertical loads (because the loads push against the abutments thus flattening the arch). As such, an arch bridge requires much stronger foundations (abutments) to resist the great *thrust* of the arch, but significantly less steel for the superstructure.

*“...It was laid down that provision should be made for a central roadway wide enough to take six lanes of traffic, and flanked on either side by two lines of railway and footway. These had to be designed to bear the following loads. The footway must be able to support a loading of 100lbs./sf. The roadway must be able to bear, in any given area measuring 30-feet by 12-feet, the weight of a motor lorry (12’x6’ wheelbase) whose axle-loads were 18K lbs. (front axle) and 36K lbs. (rear axle) – a total of rather more than 24-tons. Each of the four railway tracks must be able to bear the weight of a train composed of two 160-ton locomotives, each 65-feet long, followed by carriages weighing 2,200 lbs. per foot of length...it was stipulated that neither the finished design of the bridge nor the operations performed while it was being built should occasion any obstruction to the passage of shipping. This ruled out any reduction of the main span from below while it was under construction...”*

*Wonders of World Engineering, 1938*

The contract specification for SHB was very detailed about the loads the bridge would be required to support. The *Dead Load* specification required that the bridge support its own overall weight plus a 2% contingency factor. The *Live Load* for the roadway (57-feet wide between curbs) was based on two loading conditions; one for the cross-girders and stringers and the other for the bridge deck overall. For the former, a motorized commercial vehicle's (Lorry) concentrated load was considered to be acting on an area of 330 square-feet (30 square-meters). For the latter, a uniform load of 100-lbs. per square foot was specified. The live load for the railway (four lines of railway 4'-8&1/2" in (standard) gauge, spaced in pairs either side of the roadway with a 10-foot wide footway each side of outer railway along bridge perimeter) was based on two heavy electric locomotives followed by a long, uniform load (passenger cars). This applied to all four tracks (two on each side of the roadway. Known today as "heavy rail," the railway loading was based on a North American standard then in use.

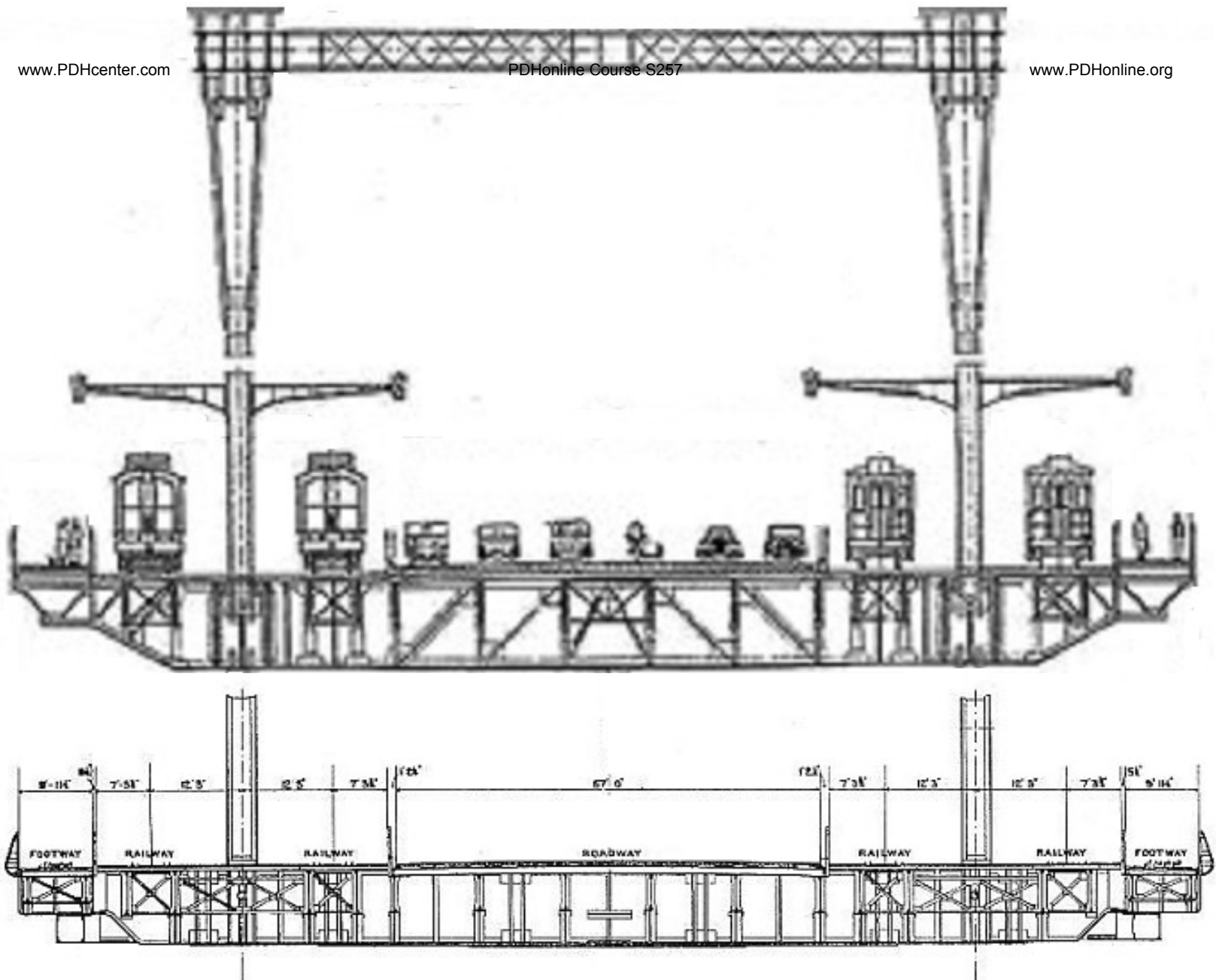



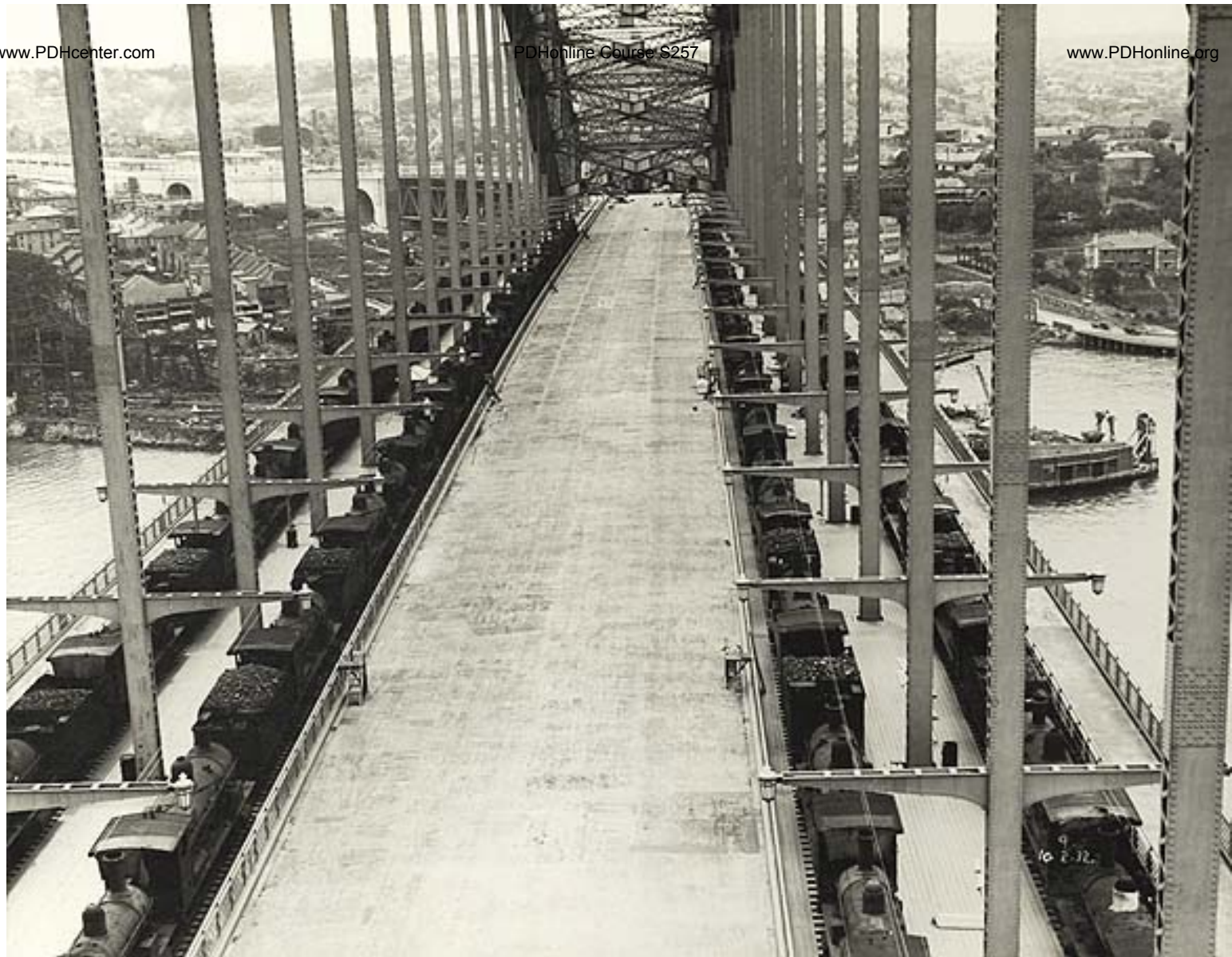

## View of bridge deck

**Note: railways (each side) fully loaded w/locomotives (load-testing)**

**A wind load allowance of thirty pounds per square foot (based on the exposed surface of two trusses) was included for both normal (lateral) and longitudinal wind directions. Also, based on the formal inquiry into the Tay (RR) bridge disaster, consideration for the lateral force of the wind on a train crossing the bridge was assumed to be three hundred pounds per linear foot.**



**Also considered in the contract specification were *Impact Loads* acting on the deck. Unlike pneumatic tires, steel train wheels have low shock-absorbing characteristics. This “hard running” is particularly noticeable at surface dislocations and/or rail joints. Though the rail lines were considered for electric passenger train use primarily, allowance was made for steam locomotives hauling freight as well. As such, for the railway an *Impact Factor* of an additional 50% to the static load on stringers plus 10% for the main bridge trusses was required. Correspondingly, the roadway added 25% and 10% respectively.**



**R.T. Ball – NSW *Minister for Works and Railways*, officially starts construction with the “Turning of the Sod” on July 28, 1923 (upper left). To his right (looking on) is JJC Bradfield. This ceremony marked the beginning of construction for the northern railway approach to the bridge, whose design/award was yet to be determined. “The Church on the Hill and the Fuzzy Tree” (upper right). The “*Fuzzy Tree*” marks the site of the *turning of the sod* ceremony and beginning of SHB.**



**Tenders were recalled in 1923 and closed on January 16, 1924. More than twenty diverse bridge designs were received from the *United States, England, Canada and Australia*. Bradfield and his team finished their review in just a few weeks and on February 16, 1924, they published their results in a document entitled: *Sydney Harbour Bridge: Report on Tenders*. As the report stated, the bridge selected would be “*the best that engineering skill can devise.*”**



Sydney Harbour Bridge

Report  
on  
Tenders

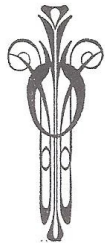

SYDNEY :  
ALFRED JAMES KENT, GOVERNMENT PRINTER.

1924.

**The February 1924 report  
Bradfield and his team  
prepared lays out in easy-to-  
read terms the economic,  
engineering and assessment  
criteria for judging the six  
competing companies and the  
twenty tenders they submitted.  
There were a total of five  
design categories tendered:**

- **Arch (5)**
- **Cantilever-Arch (2)**
- **Cantilever (7)**
- **Cantilever-Suspension (1)**
- **Suspension (5)**



## 1.—The Firms Tendering.

On 16th January, 1924, tenders were opened in the Minister's room, when each tender was initialled by the Minister and the Under Secretary for Public Works.

Six firms submitted twenty tenders, viz. :—

SIR WM. ARROL & Co., Glasgow, in conjunction with SIR JOHN WOLFE BARRY & Co., London ... ..	Two tenders.
DORMAN LONG & Co., Middlesbrough and Sydney ... ..	Seven tenders.
CANADIAN BRIDGE COMPANY, Walkerville, Ontario ... ..	Two tenders.
McCLINTIC MARSHALL PRODUCTS COMPANY, New York ... ..	Five tenders.
ENGLISH ELECTRIC COMPANY OF AUSTRALIA LTD., Sydney ... ..	Three tenders.
THE GONINAN BRIDGE CORPORATION, New- castle ... ..	One tender.

*“...The specification and plans issued by the Minister (for Public Works), as authorised by the Sydney Harbor Bridge Act of 1922, invited tenders for bridges of the cantilever and arch types in accordance with the official designs, but subject to certain variations allowed by the specification. Tenderers were not invited to submit independent designs...On my advice as Chief Engineer, tenders were called for cantilever and arch bridges only; tenders, however, have been submitted for suspension bridges, and I have given these tenders the same careful consideration as the tenders submitted for cantilever and arch bridges...”*

**JJC Bradfield - Chief Engineer, SHB**

**RE: excerpt from: *Sydney Harbour Bridge: Report on Tenders***

## 2.—Summary of Tenders.

The following summary gives the types of bridges, amounts of tender, the total tonnages of metalwork, the tonnages to be fabricated in New South Wales, the tonnages to be imported and the places of fabrication outside New South Wales, if imported. The tonnages do not include the gunmetal plates and castings for the portals or the steel rails for the railway tracks.

Firm.	Type of Bridge and Amount of Tender.					Fabricated Metalwork.			
	Arch.	Cantilever-Arch.	Cantilever.	Suspension.	Centilever-Suspension.	Total tonnage.	In N.S.W. Tons.	Imported.	
								Tonnage.	Country.
	£ s. d.	£ s. d.	£ s. d.	£ s. d.	£ s. d.				
Mr. Bradfield's Estimate ...	4,339,530 0 0	.....	.....	.....	.....	*46,600	All.	Nil.	.....
Do do ...	.....	.....	4,704,840 0 0	.....	.....	161,000	All.	Nil.	.....
Sir Wm. Arrol & Co. ...	.....	.....	4,978,488 7 8	.....	.....	57,653	13,495	44,158	Scotland.
Do ...	4,645,351 7 8	.....	.....	.....	.....	40,228	13,682	26,546	do.
Darman Long & Co., A1 ...	3,499,815 15 0	.....	.....	.....	.....	50,626	All.	Nil.	.....
Do A2 ...	4,233,105 4 7	.....	.....	.....	.....	49,146	All.	Nil.	.....
Do A3 ...	4,217,721 11 10	.....	.....	.....	.....	50,288	A1.	Nil.	.....
Do B1 ...	.....	3,709,686 2 6	.....	.....	.....	56,953	All.	Nil.	.....
Do B2 ...	.....	3,941,728 6 3	.....	.....	.....	56,362	A1.	Nil.	.....
Do C1 ...	.....	.....	4,551,758 13 3	.....	.....	65,453	All.	Nil.	.....
Do C2 ...	.....	.....	4,310,812 1 0	.....	.....	65,303	All.	Nil.	.....
Canadian Bridge Co....	.....	.....	5,313,404 9 4	.....	.....	38,064	4,230	33,834	Canada and U.S.A.
Do ...	.....	.....	.....	5,091,202 18 4	.....	38,015	5,400	32,615	do.
McClintic Marshall Products Co., A	.....	.....	6,499,377 0 0	.....	.....	50,283	13,000	37,283	U.S.A.
Do B	.....	.....	5,958,356 0 0	.....	.....	49,115	15,000	34,115	do.
Do C	.....	.....	5,654,531 10 0	.....	.....	50,191	17,000	33,191	do.
Do D	.....	.....	.....	6,047,547 0 0	.....	43,059	15,000	28,059	do.
Do E	6,053,565 0 0	.....	.....	.....	.....	45,854	12,000	33,854	do.
English Electric Co. of Australia	.....	.....	.....	5,609,125 2 1	.....	46,108	All.	Nil.	.....
Do	.....	.....	.....	4,943,763 0 5	.....	46,108	All.	Nil.	.....
Do	.....	.....	.....	5,109,333 12 11	.....	46,108	All.	Nil.	.....
Gannan Bridge Corporation Ltd.	.....	.....	.....	.....	10,712,015 19 8	43,939	24,236	19,703	Belgium.

\* Nickel steel 30 7 per cent. of tonnage. † Nickel steel 18 7 per cent. of tonnage.

*“...the tender of the Goninan Bridge Corporation of Newcastle is for a cantilever-suspension bridge, the centre span of which is really an independent suspension bridge hung from cantilever arms...whilst the Goninan Bridge Corporation of Newcastle is tendering in conjunction with the firm of Baume Marpent, of Haine St. Pierre, Belgium, also a firm of the highest repute as bridge fabricators and builders... have shops established at Newcastle carrying out general engineering fabrication and repairs as are required at a coal-mining and shipping centre...does not come within the scope of the specifications or of the Sydney Harbor Bridge Act...”*

**JJC Bradfield - Chief Engineer, SHB**

**RE: excerpt from: *Sydney Harbour Bridge: Report on Tenders***

PLAN No. 1.

# CONINAN BRIDGE CORPORATION

## TENDER FOR A CANTILEVER SUSPENSION BRIDGE

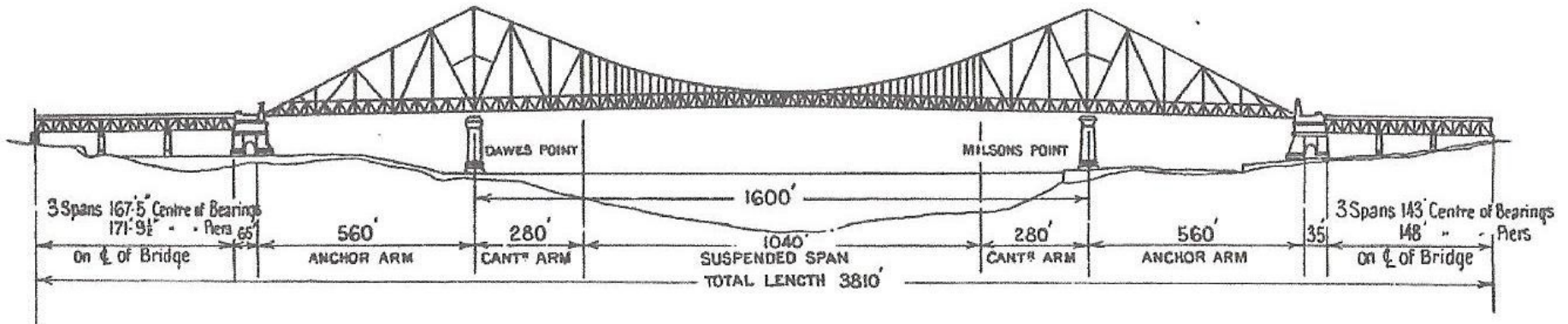

Granite facing throughout ... .. £10,712,015 : 19 : 8

*“...The three tenders of the English Electric Company of Australia, Limited, are for a suspension bridge with a continuous stiffening truss...Associated with the English Electric Company of Australia are Dr. D.B. Steinman and Mr. H.P. Robinson of New York City, both well known in engineering circles in America...have their main works at Clyde, modern shops well equipped for the manufacture of hydraulic, electric, and refrigerating machinery of the highest class, but the firm has not had experience in the fabrication of the class of bridgework required for the Sydney Harbour Bridge...does not come within the scope of the specification of the Sydney Harbour Bridge Act...”*

**JJC Bradfield - Chief Engineer, SHB**

**RE: excerpt from: *Sydney Harbour Bridge: Report on Tenders***



# THE ENGLISH ELECTRIC CO. OF AUSTRALIA LTD.

## TENDERS FOR A SUSPENSION BRIDGE

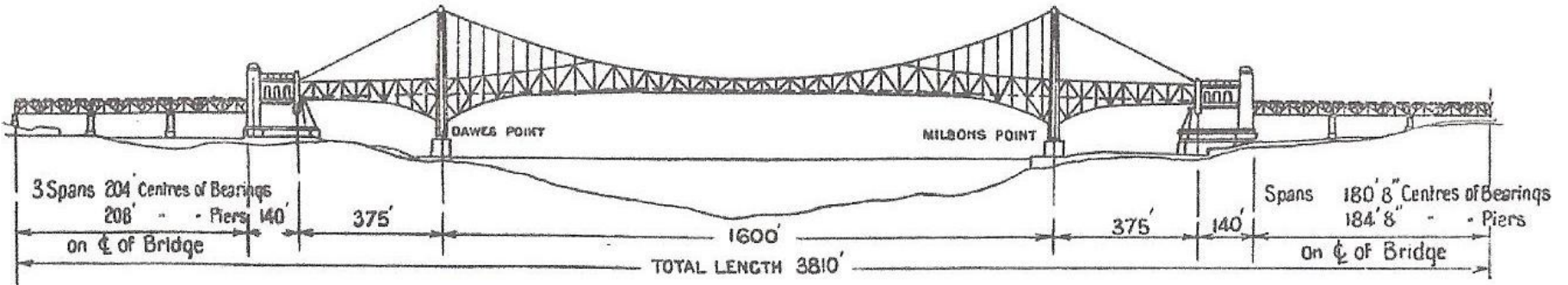

Alternative 1. Granite facing throughout	...	...	...	...	£5,609,125	:	2	:	1
Alternative 2. Concrete facing throughout	...	...	...	...	£4,943,763	:	0	:	5
Alternative 3. Brick facing with granite quoins	...	...	...	...	£5,109,333	:	12	:	11

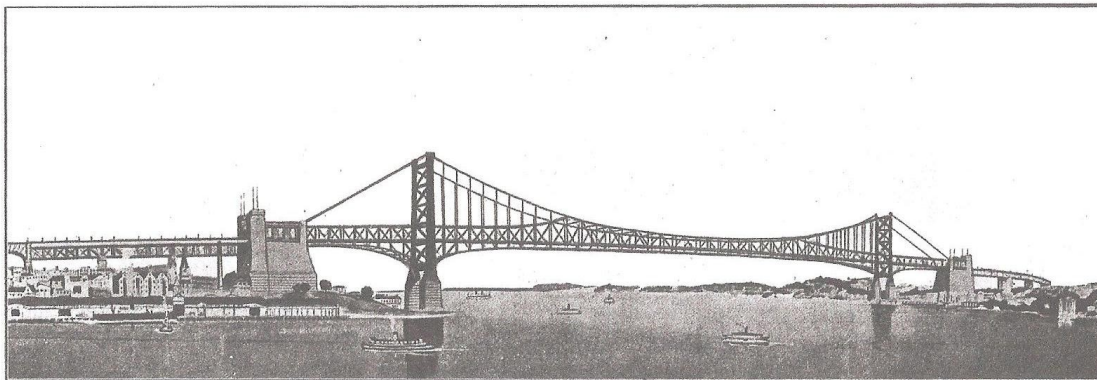

Photograph No. 1.—English Electric Company of Australia.

***“...McClintic Marshall Products Company...have shops established in other parts of the world, capable of, with little if any expense, fabricating a bridge of the magnitude of the Sydney Harbour Bridge...have as yet no Australian establishment or connections, but they will have made arrangements to fabricate portions of the steelwork locally, if awarded the contract...ranks among the foremost bridge fabricating establishments and contracting firms in the world...”***

**JJC Bradfield - Chief Engineer, SHB**

**RE: excerpt from: *Sydney Harbour Bridge: Report on Tenders***

TENDERS FOR A CANTILEVER BRIDGE

Tender A

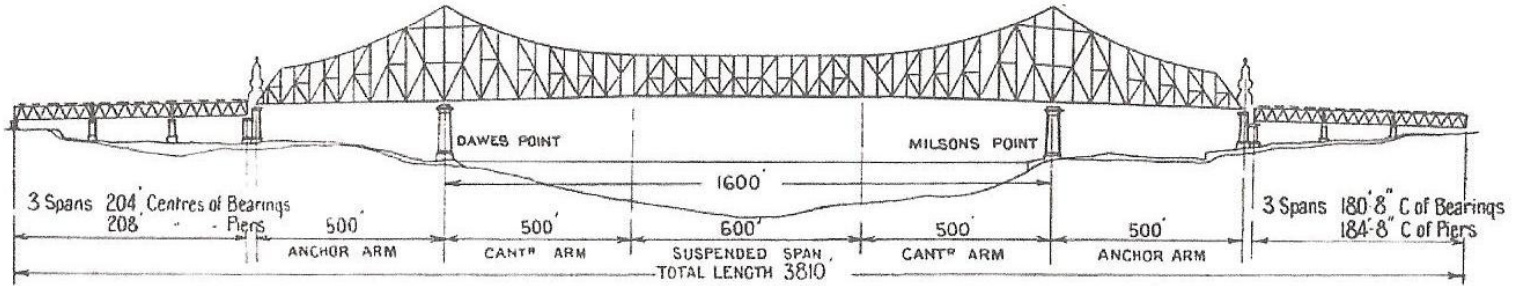

Granite facing throughout ... .. £6,499,377 : 0 : 0

Tender B

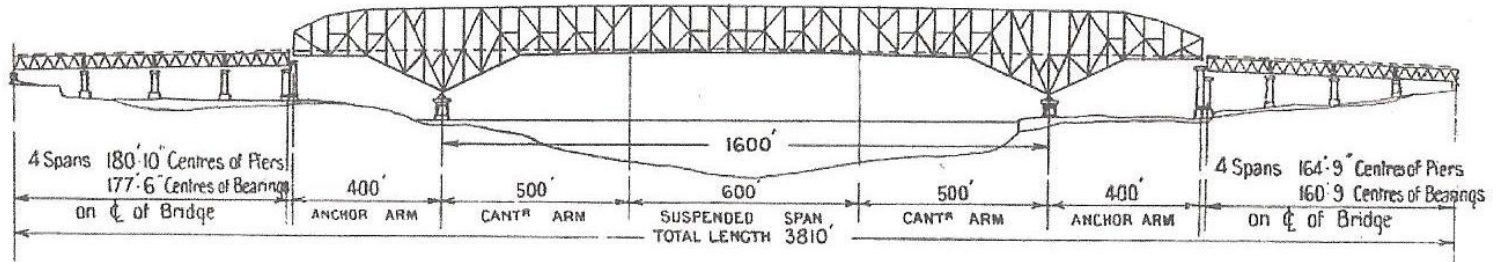

Granite facing throughout ... .. £5,958,356 : 0 : 0

Tender C

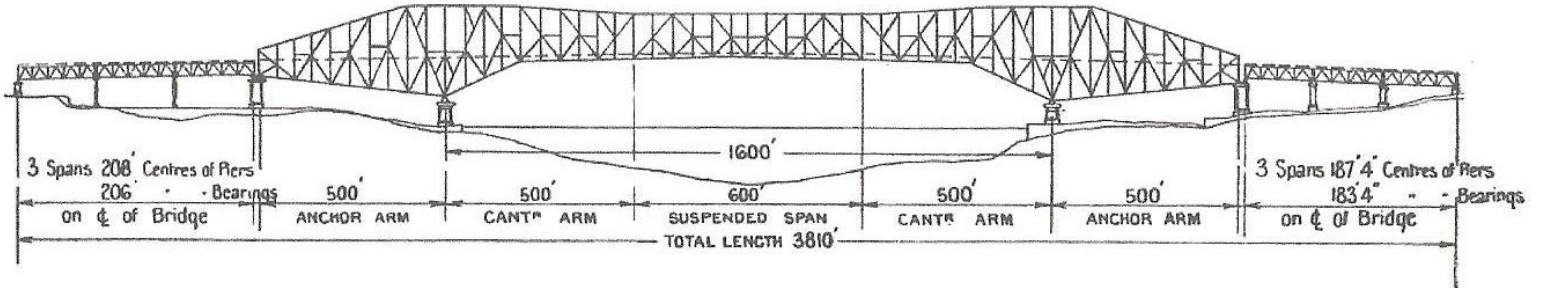

Granite facing throughout ... .. £5,654,531 : 10 : 0



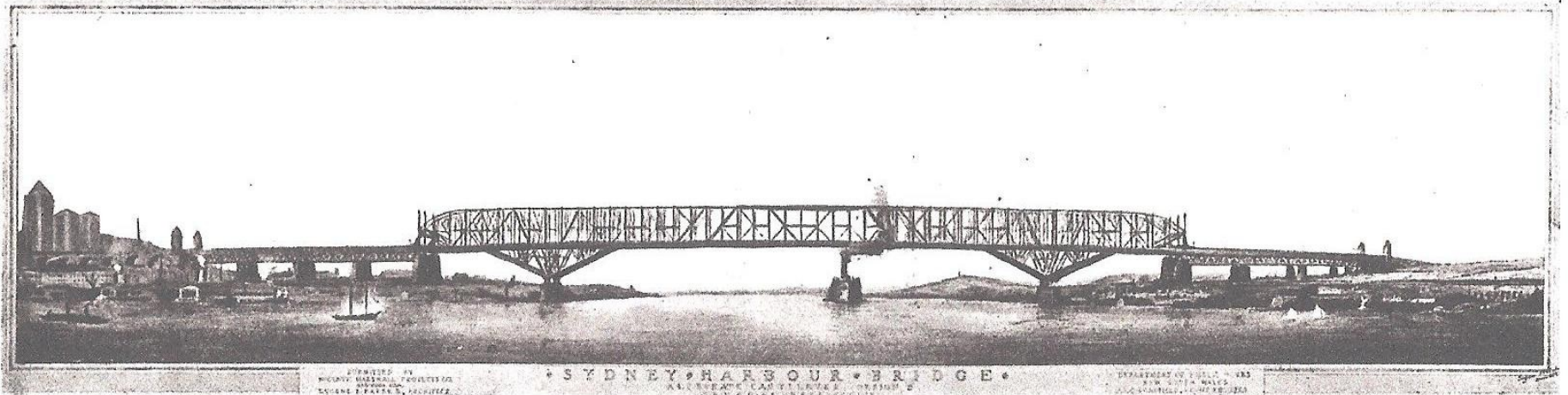

Photograph No. 2.—McClintic Marshall Products Company. Tender B.

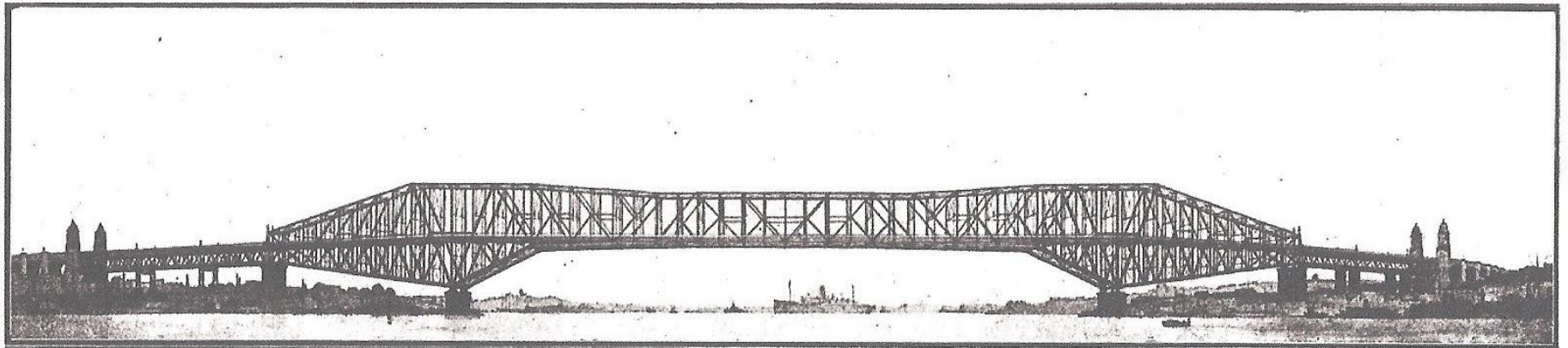

Photograph No. 3.—McClintic Marshall Products Company. Tender C.

***“...the so-called ‘inverted arches’...of the McClintic Marshall Products Company are really suspension bridges designed in general conformity with the specification; but this tender, however, does not come within the scope of the Sydney Harbor Bridge Act...”***

**JJC Bradfield - Chief Engineer, SHB**

**RE: excerpt from: *Sydney Harbour Bridge: Report on Tenders***

McCLINTIC MARSHALL PRODUCTS CO.

TENDER FOR A SUSPENSION BRIDGE

Tender D

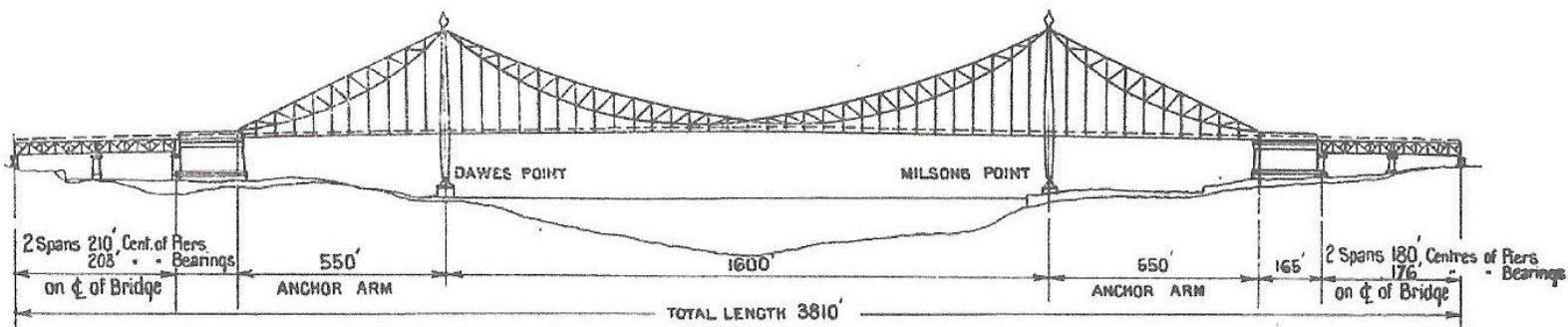

Granite facing throughout

£6,047,547 : 0 : 0

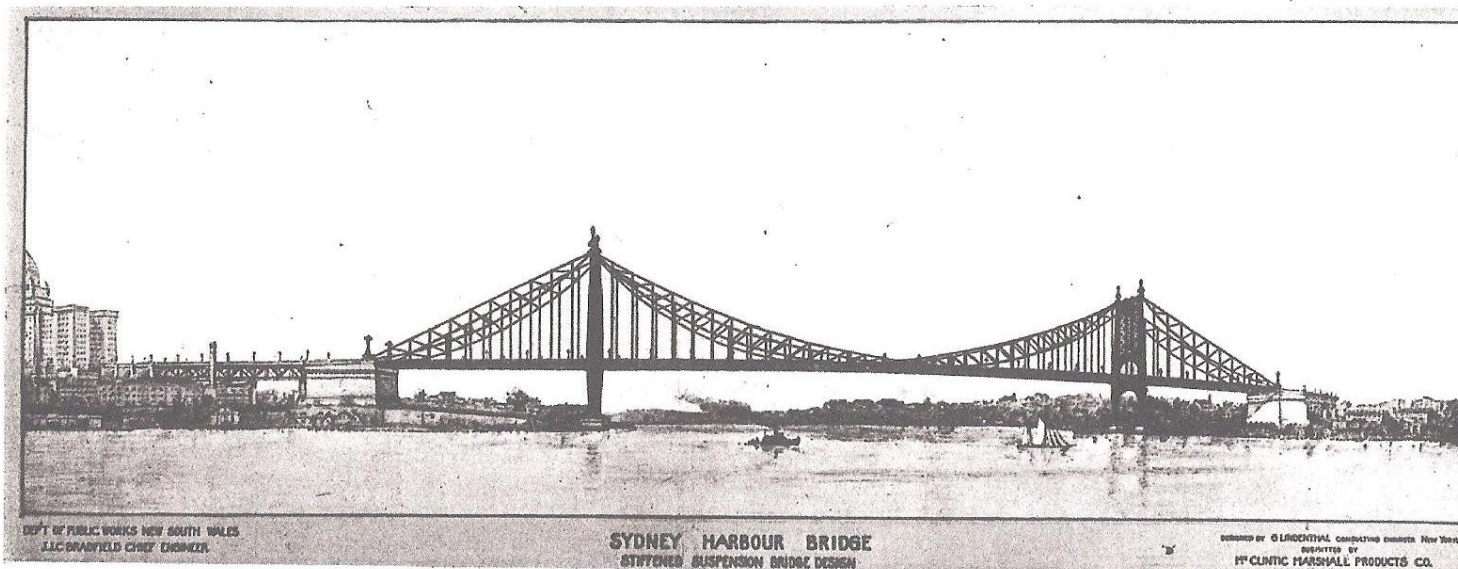

Photograph No. 4.—McClintic Marshall Products Company. Tender D.



# McCLINTIC MARSHALL PRODUCTS Co.

## TENDER FOR AN ARCH BRIDGE

Tender E

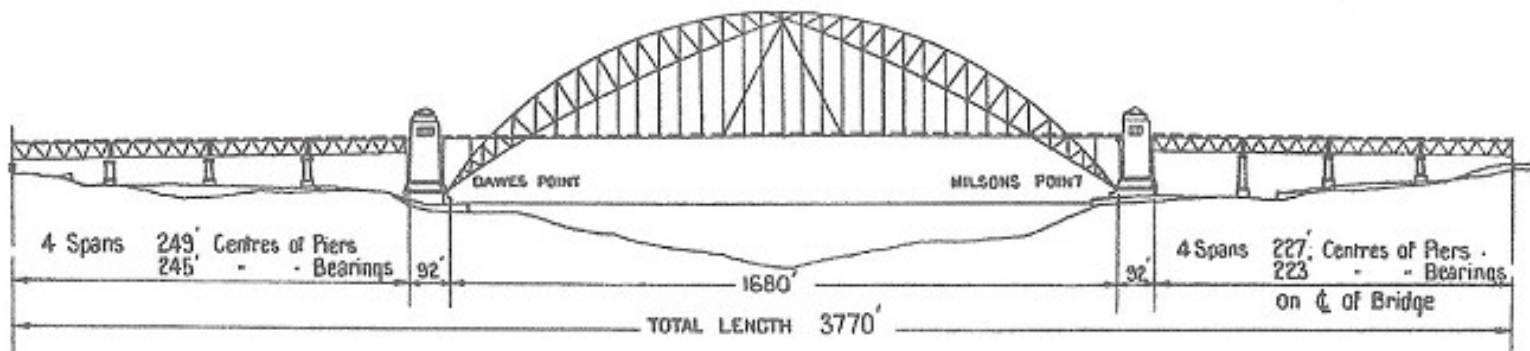

Granite facing throughout ... .. £6,053,565 : 0 : 0

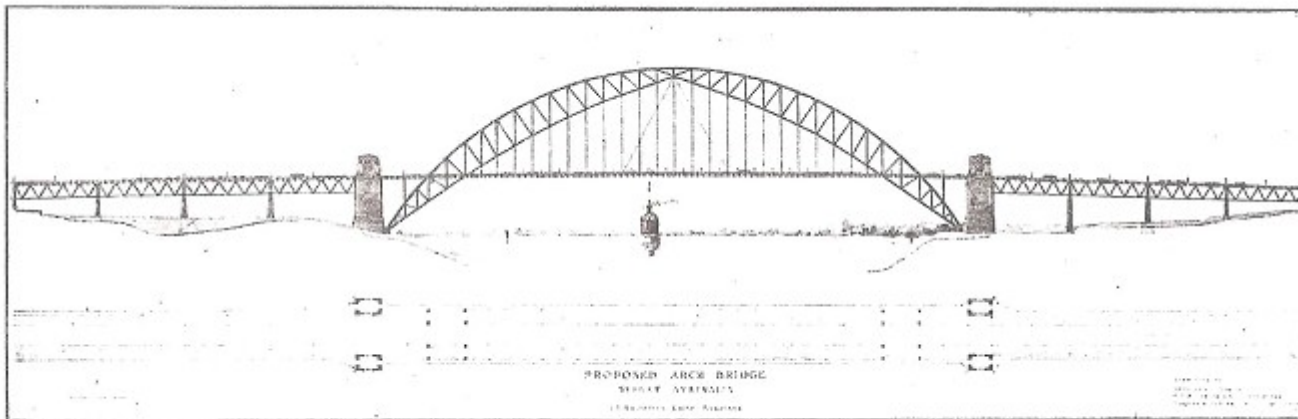

Photograph No. 5.—McClintic Marshall Products Company. Tender E.

***“...Canadian Bridge Company...have shops established in other parts of the world, capable of, with little if any expense, fabricating a bridge of the magnitude of the Sydney Harbour Bridge...have as yet no Australian establishment or connections, but they will have made arrangements to fabricate portions of the steelwork locally, if awarded the contract...ranks among the foremost bridge fabricating establishments and contracting firms in the world...”***

**JJC Bradfield - Chief Engineer, SHB**

**RE: excerpt from: *Sydney Harbour Bridge: Report on Tenders***

# THE CANADIAN BRIDGE CO., LTD.

## TENDER FOR A CANTILEVER BRIDGE

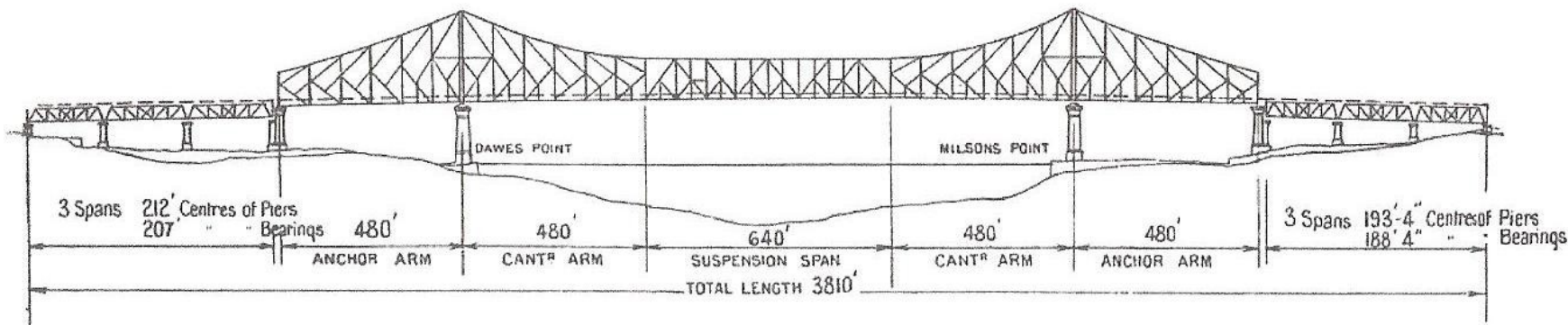

[Granite facing throughout ... .. £5,313,404 : 9 : 4

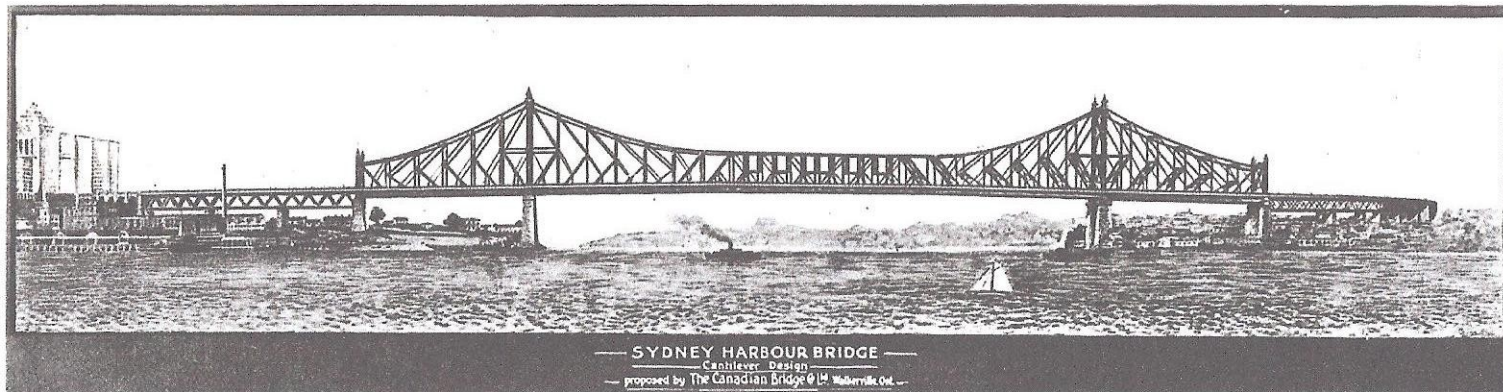

Photograph No. 6.—Canadian Bridge Company. Tender A.

*“...the so-called ‘inverted arches’...of the Canadian Bridge Company are really suspension bridges designed in general conformity with the specification; but this tender, however, does not come within the scope of the Sydney Harbor Bridge Act...”*

**JJC Bradfield - Chief Engineer, SHB**

**RE: excerpt from: *Sydney Harbour Bridge: Report on Tenders***

# THE CANADIAN BRIDGE CO., LTD.

## TENDER FOR A SUSPENSION BRIDGE

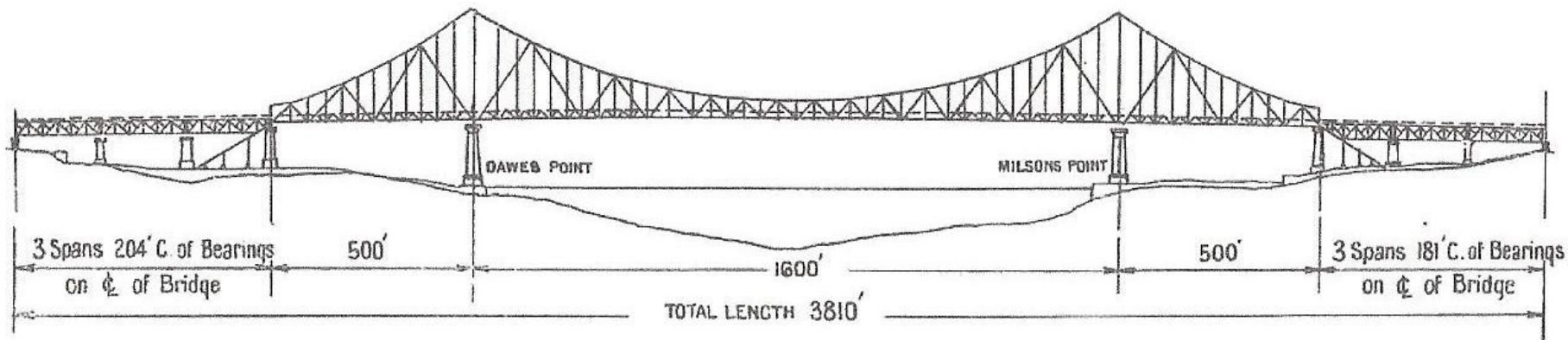

Granite facing throughout ... .. £5,091,202 : 18 : 4

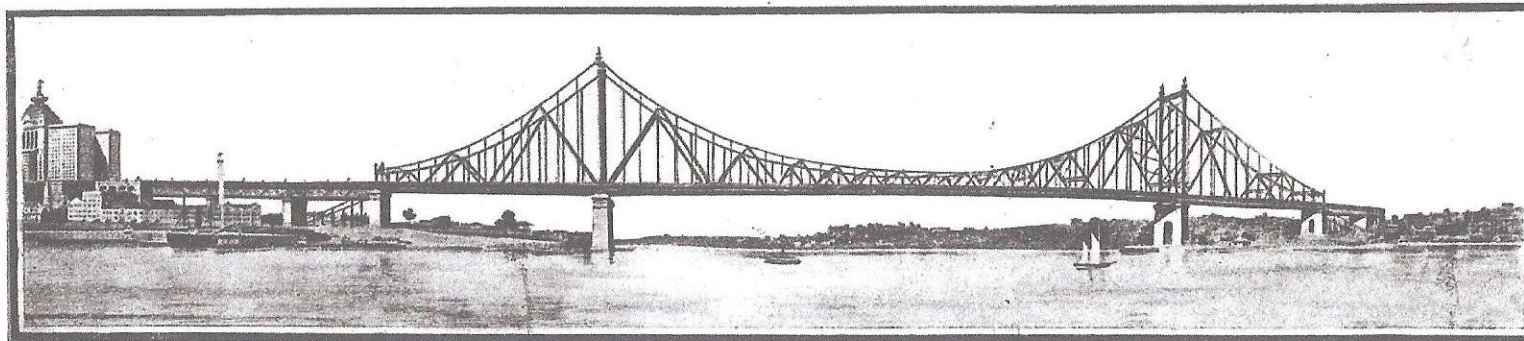

Photograph No. 7.



***“...Sir William Arrol & Company...have shops established in other parts of the world, capable of, with little if any expense, fabricating a bridge of the magnitude of the Sydney Harbour Bridge...have as yet no Australian establishment or connections, but they will have made arrangements to fabricate portions of the steelwork locally, if awarded the contract...ranks among the foremost bridge fabricating establishments and contracting firms in the world...”***

**JJC Bradfield - Chief Engineer, SHB**

**RE: excerpt from: *Sydney Harbour Bridge: Report on Tenders***



PLAN No. 8.

# SIR W<sup>M</sup> ARROL & Co., LTD TENDER FOR A CANTILEVER BRIDGE

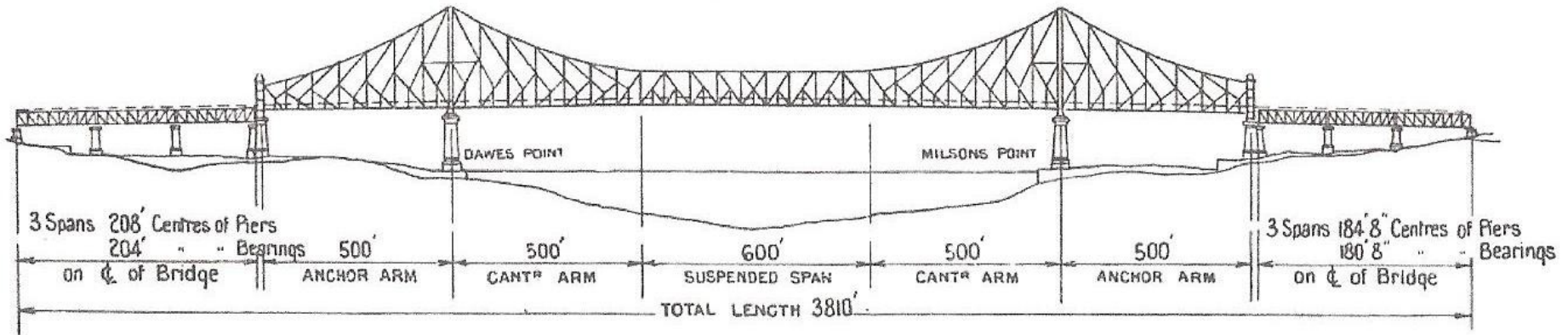

Granite facing throughout ... .. £4,978,488 : 7 : 8

PLAN No. 9.

# SIR W<sup>M</sup> ARROL & Co., LTD.

## TENDER FOR AN ARCH BRIDGE

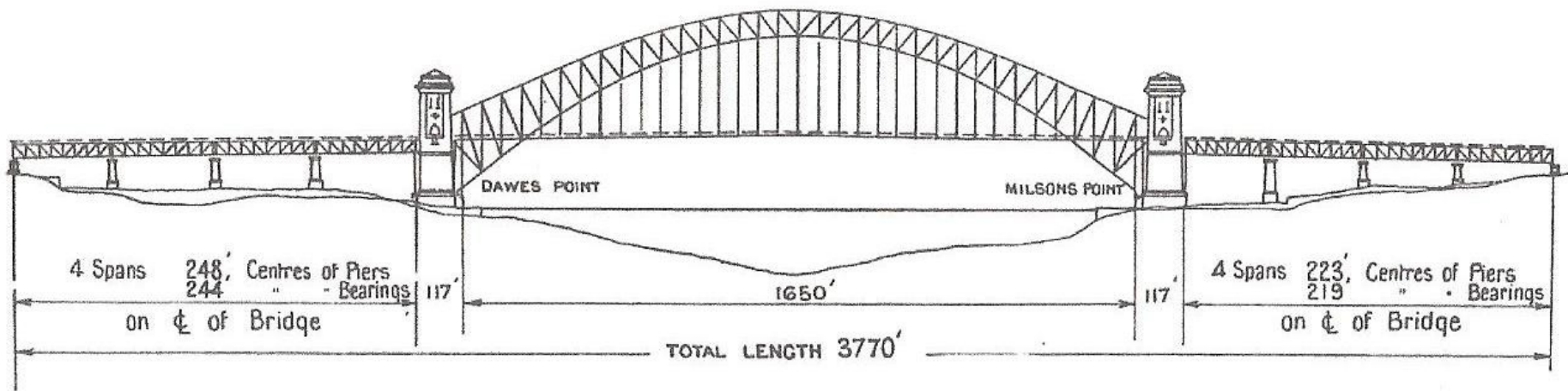

Granite facing throughout ... .. £4,645,351 : 7 : 8

*“...Dorman, Long & Company...have shops established in other parts of the world, capable of, with little if any expense, fabricating a bridge of the magnitude of the Sydney Harbour Bridge...is also an Australian firm, having two well established steel fabricating shops in Australia – one at Sydney, the other at Melbourne – already constructing medium heavy steel structures, similar work to that required for the approach spans, cross-girders and decking of the Sydney Harbour Bridge...ranks among the foremost bridge fabricating establishments and contracting firms in the world...”*

**JJC Bradfield - Chief Engineer, SHB**

**RE: excerpt from: *Sydney Harbour Bridge: Report on Tenders***

# DORMAN LONG & Co. LTD.

## TENDERS FOR AN ARCH BRIDGE

Tender A1

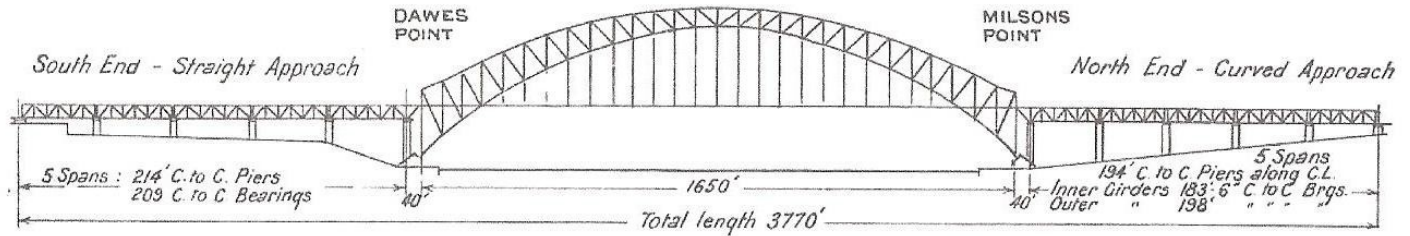

Alternative (A1). Without abutment towers, granite masonry facing ... .. £3,499,815 : 15 : 0

Tender A2

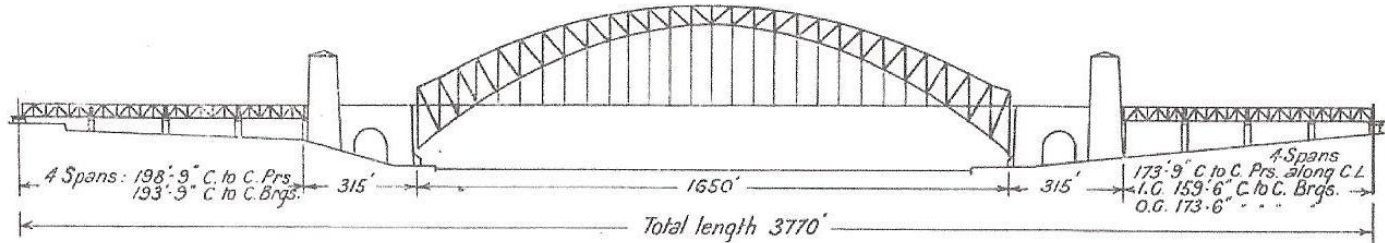

Alternative (A2). Abutment towers, Tenderer's own design, granite facing to plinth level, precast concrete blocks above plinth level ... .. £4,233,105 : 4 : 7

Tender A3

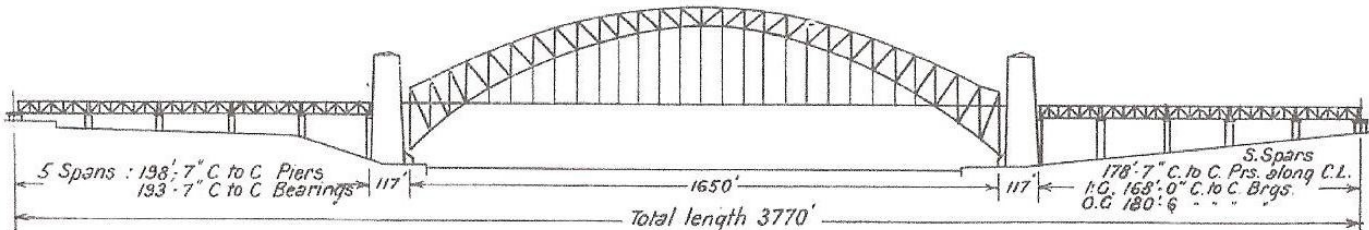

(A3) In accordance with Official Design, granite facing throughout ... .. £4,217,721 : 11 : 10

(A3) Alternative. In accordance with Official Design, but with towers of precast concrete blocks above plinth level ... .. £3,977,721 : 11 : 10



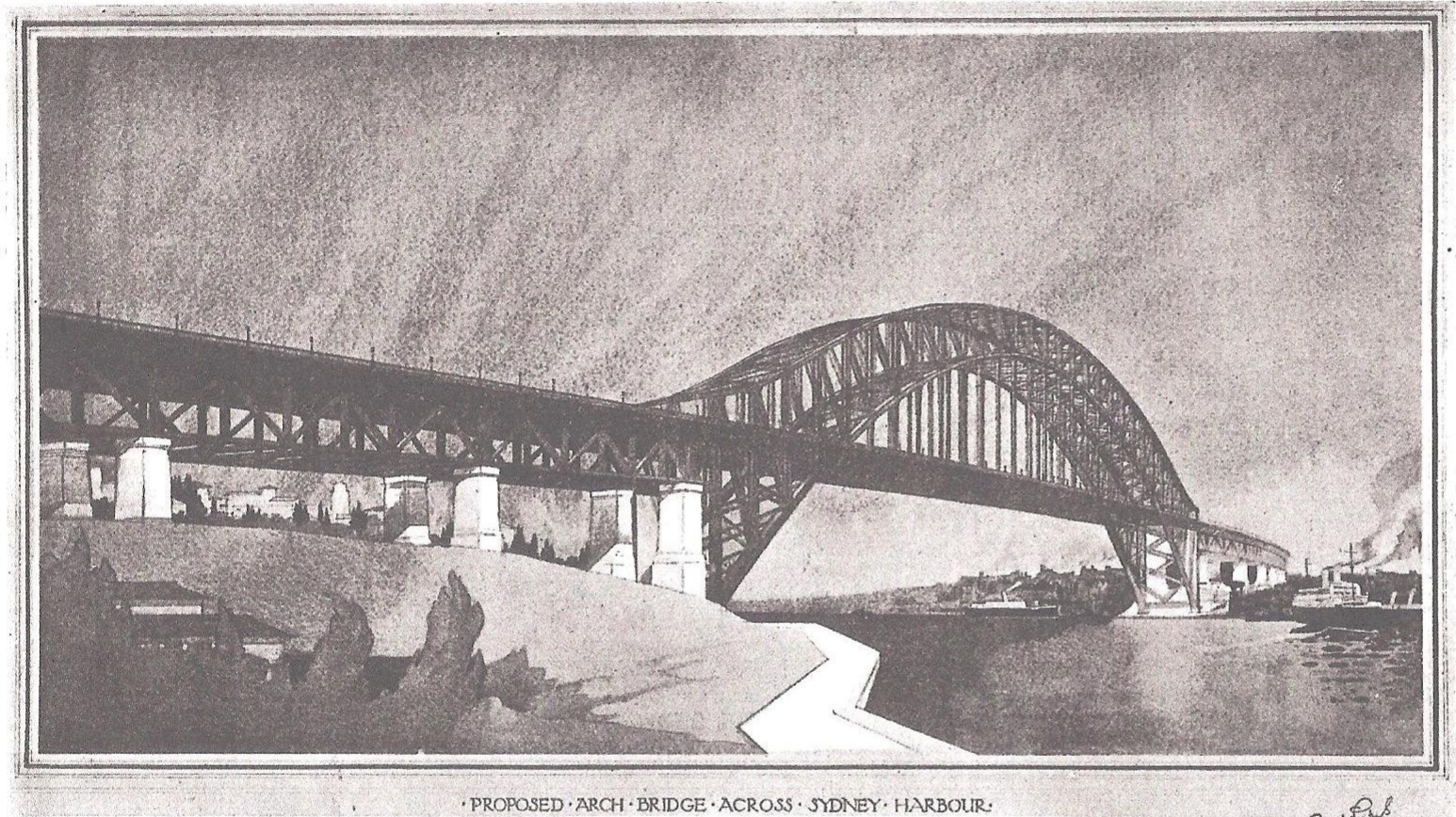

Photograph No. 8.—Dorman Long and Co. Tender A1.



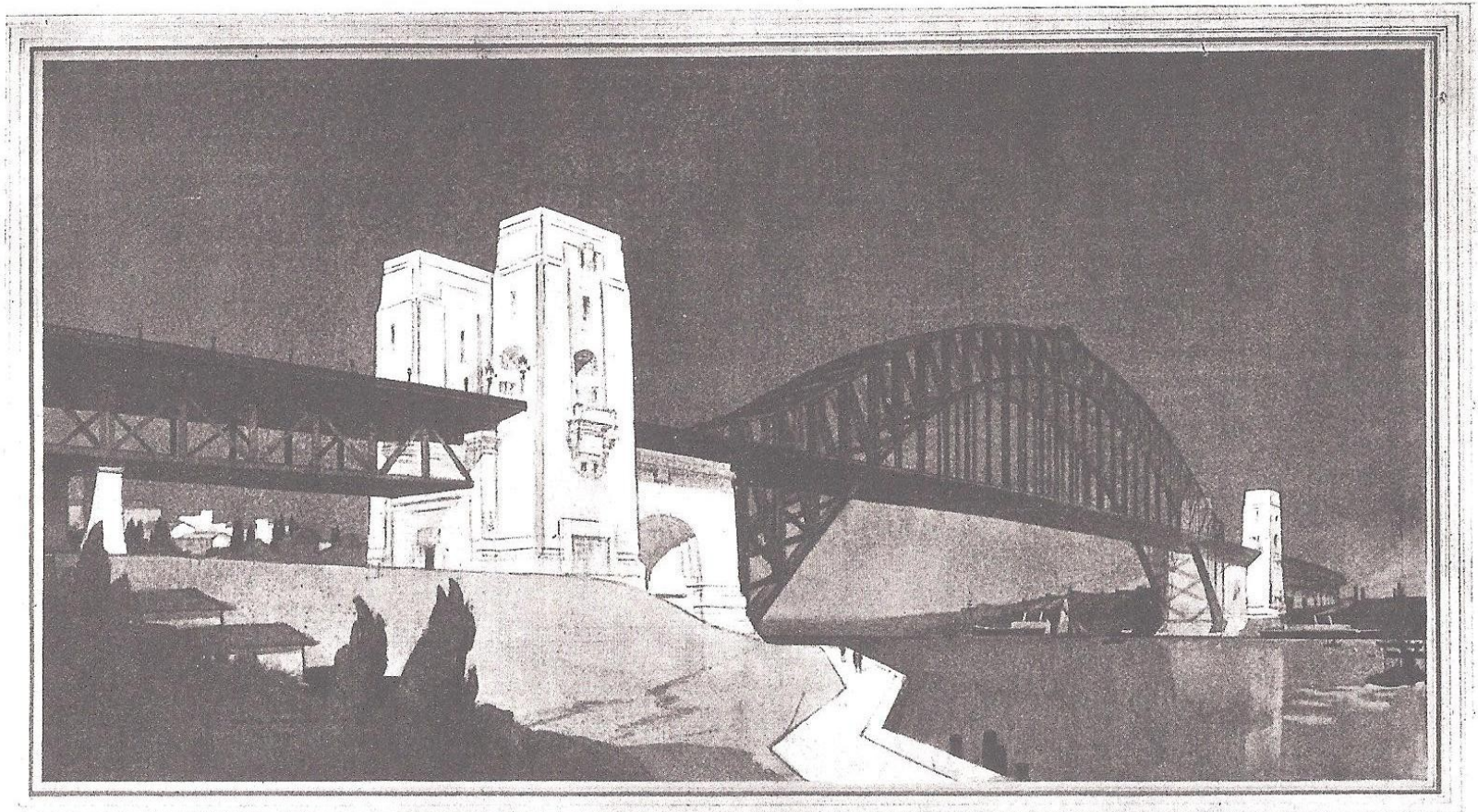

PROPOSED ARCH BRIDGE ACROSS SYDNEY HARBOUR

*See page 10 of the  
report  
Dorman Long & Co.  
Sydney N.S.W.  
1910*

Photograph No. 9.—Dorman Long and Co. Tender A2.



# DORMAN LONG & CO. LTD.

PLAN No. 11.

## TENDERS FOR A CANTILEVER BRIDGE

Tender B1

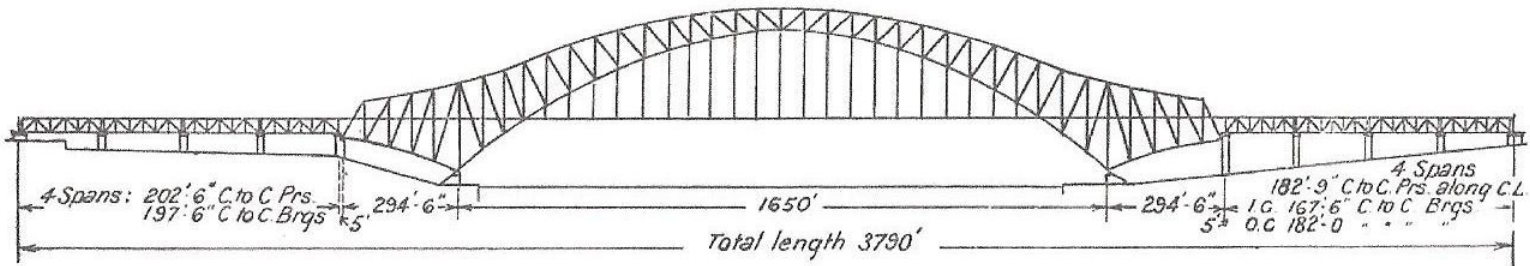

Alternative (B1). Granite facing throughout ... .. £3,709,686 : 2 : 6

Tender B2

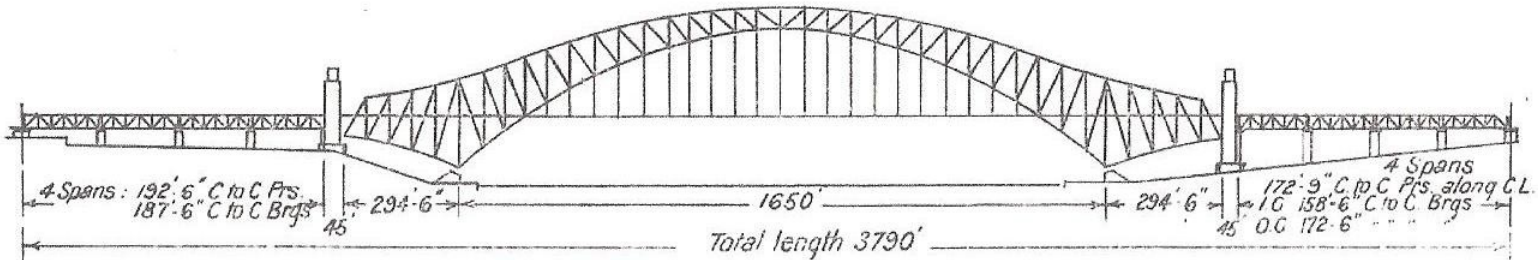

(B2). Ornamental towers, granite facing up to plinth level, precast concrete blocks above plinth level ... .. £3,941,728 : 6 : 3  
 (B2). Alternative Granite facing throughout ... .. £4,175,523 : 0 : 0

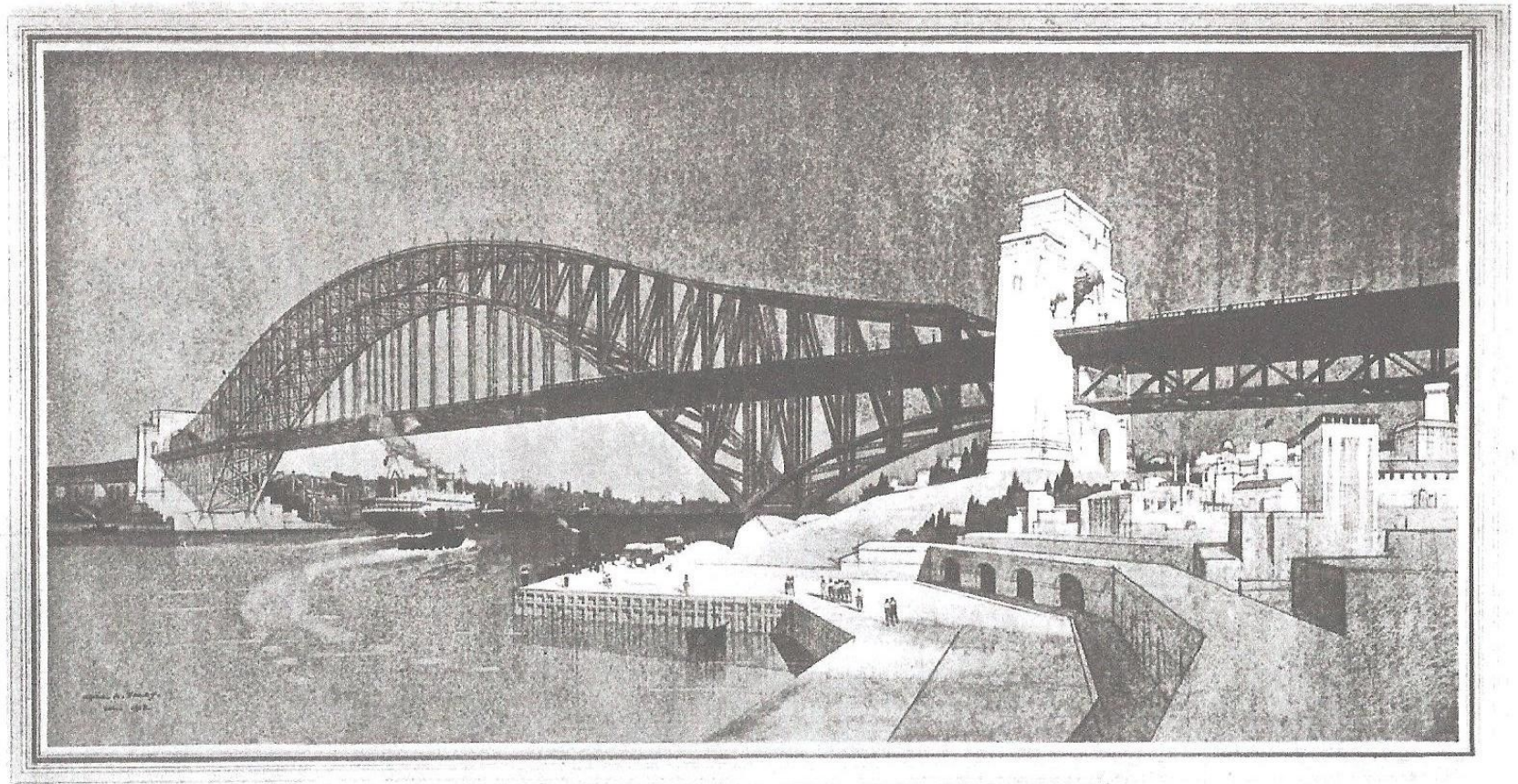

•PROPOSED • CANTILEVER • ARCH • BRIDGE • ACROSS • SYDNEY • HARBOUR•

*John B. ...  
1875  
...  
...  
...*

Photograph No. 10.—Dorman Long and Co. Tender B2.



# DORMAN LONG & CO. LTD.

## TENDERS FOR A CANTILEVER ARCH BRIDGE

Tender C1

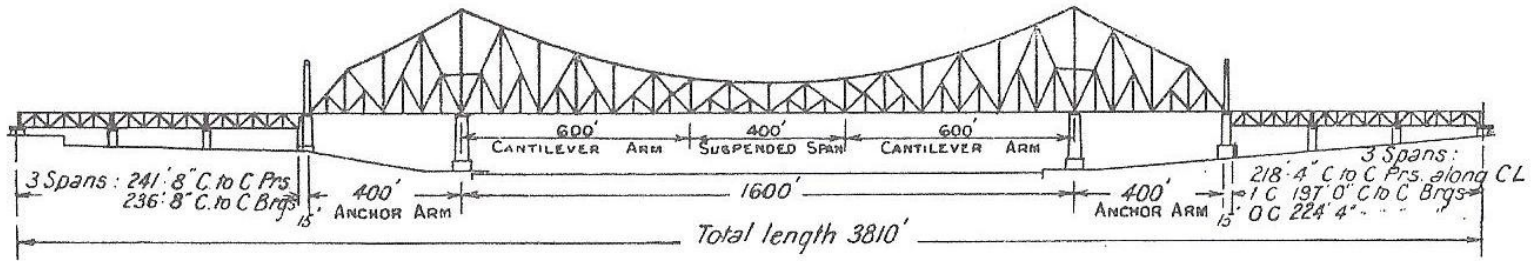

Alternative (C1). Granite facing throughout ... .. £4,551,758 : 13 : 3

Tender C2

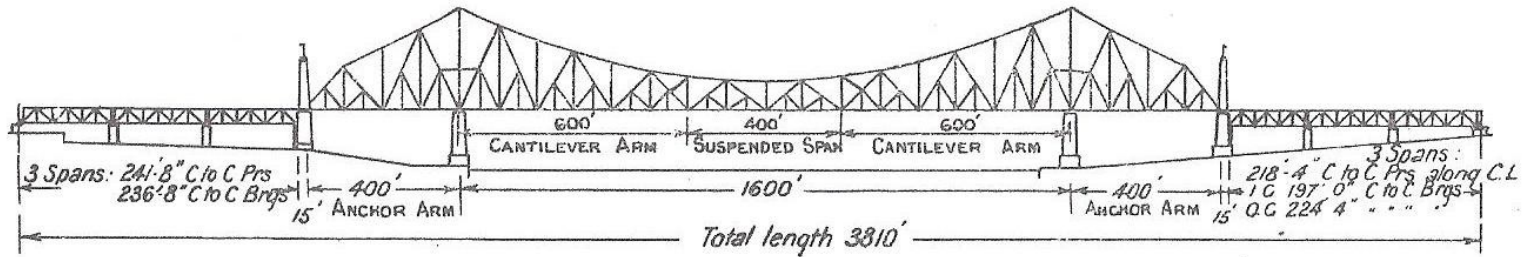

Alternative (C2). Facing with precast concrete blocks ... .. £4,310,812 : 1 : 0

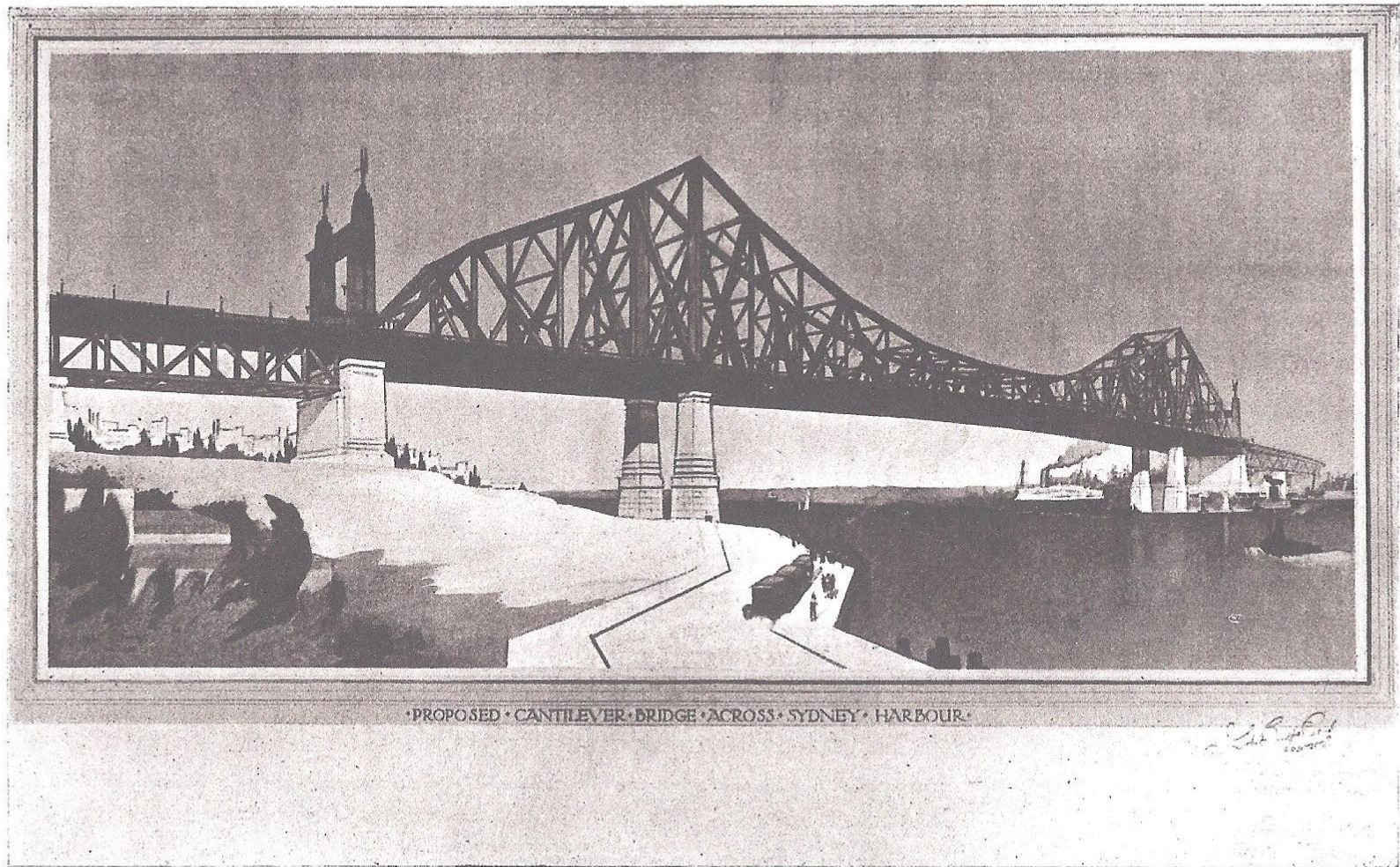

Photograph No. 11.—Dorman Long and Co. Tender C2.

**And the winner is....**



*“This tender, Plan No.10, is also for a two-hinged arch bridge of 1,650-feet span, but with alternative masonry abutment towers faced with pre-cast concrete blocks above plinth level in lieu of granite facing. The length of the main bridge and approach spans is 3,770-feet. Owing to the design of the abutment towers, which are much longer than those provided in the official design, four steel approach spans of 193-feet 9-inches are required on the southern side, and on the northern side four spans of 166-feet 6-inches centre to centre of bearings. Tendered cost 4,233,105 pounds. The bridge is attractive in appearance, but the abutment towers are too massive.”*

**RE: the tender (A2) of Dorman, Long & Co., Ltd., Middlesbrough, England, January 1924**

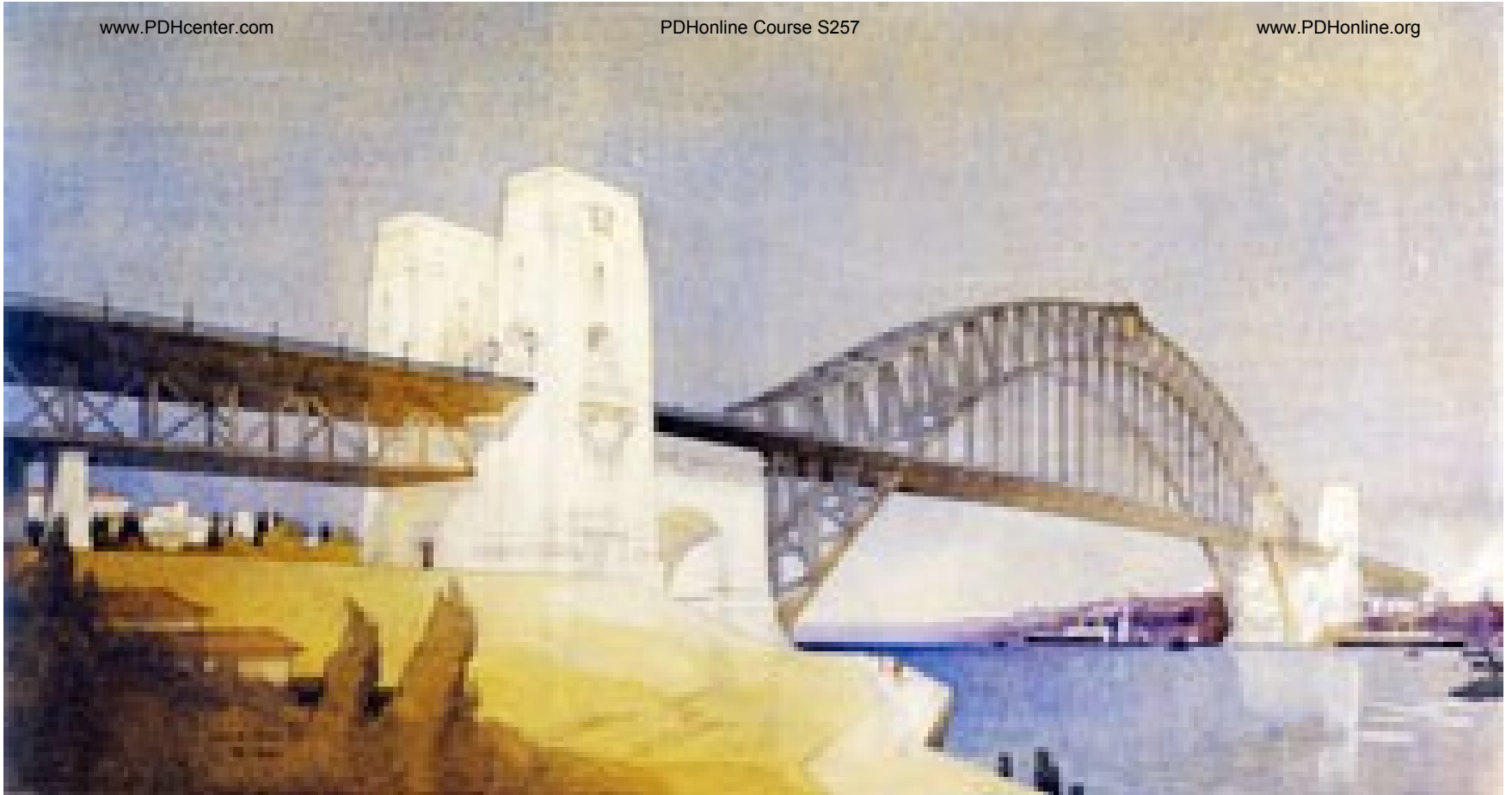

**Plan No. 10 / Tender A2 – *Dorman, Long & Company*  
Winner of the SHB Competition**



*“The recommended tender was a two-hinged steel arch with abutment towers faced with granite that was one of seven potential schemes submitted by Dorman Long for three different types of bridges. Importantly, the tender was ‘In accordance with the specifications and the official design.’ In Bradfield’s justification of the winning selection, it is clear that he favoured the design for its appearance, ‘dignity’ in use of granite, and engineering qualities. Significantly, Dorman Long was the only tenderer to provide for the whole of the fabrication to be carried out in Australia.”*

**RE: excerpt from: *Bridging Sydney***



*“...The contract for the new bridge was finally allotted (March 1924) to the British firm of Dorman, Long & Co., of Middlesbrough. Their consulting engineer, Mr. Ralph Freeman, had prepared seven individual tenders...The structure was to be chiefly of steel, but the design also embodied granite-faced concrete piers and pylons, the architectural details of these features conforming to designs provided by Sir John Burnet and Partners...”*

*Wonders of World Engineering, 1938*

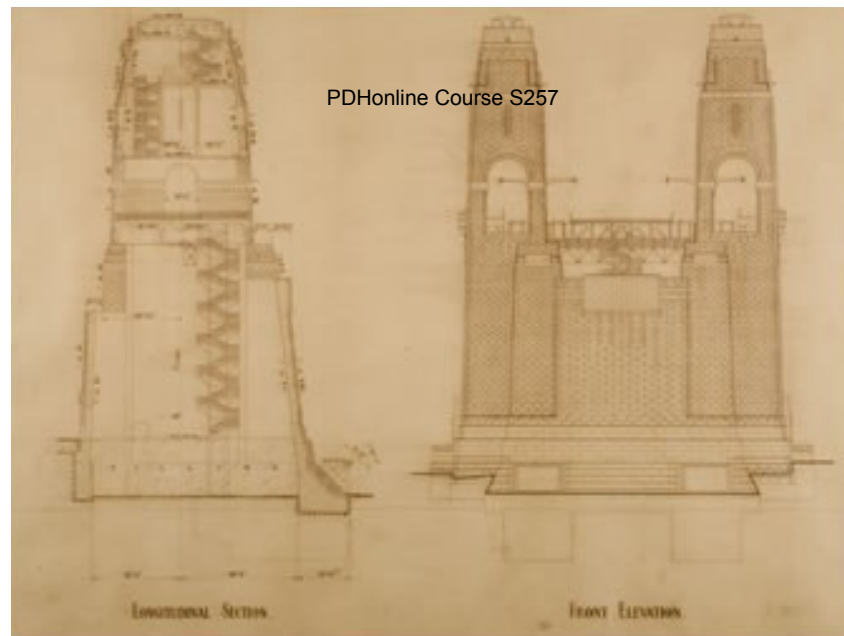

**The granite-faced, reinforced concrete twin-towered *Pylons* (one at each end of the arch) serve no structural purpose other than to support the deck (between/through the twin towers). However, their great weight assists greatly in resisting the vertical reaction produced by the thrust of the arch on the abutment below. Mainly, they provide an aesthetic/visual balance to the utilitarian design of the steel arches. Modernist Scottish architect *Thomas Smith Tait* (1882-1954) – a partner in the architectural firm of *John Burnet & Partners*, was their designer. They stand 292-feet (89-meters) tall and are faced with **Moruya (NSW) granite.****









# **The Greater Good**



**July 1924**

**Wreckers begin demolishing buildings for the northern approach**



**For the residents of Sydney, the bridge and associated rail extensions would elevate their city to a world-class metropolis and open up the north shore for expansion of the city, but not without a price. The *Dawes Point Battery*, begun in 1791 (for the defense of *Sydney Town*) would need to be demolished as well as the attached fort buildings (designed by Francis Greenway in 1815). The southern approaches caused much disruption having need to demolish fashionable houses on the ridge above the harbor rocks (part of the rocks had to be demolished as well). On the north shore, hundreds of homes and businesses would be demolished - with minimal or no compensation to the owners, causing great social strife. On the bright side, the bridge would be a candle in the darkness of the world-wide depression and breath new life into Sydney and its struggling economy.**

SPANNING SYDNEY HARBOUR

# WONDERS OF WORLD ENGINEERING

www.PDHcenter.com

PDHonline Course S257

www.PDHonline.org

PART  
48

7<sup>D</sup>  
WEEKLY



*“Future generations will  
judge our generation by  
our works...”*

**JJC Bradfield, 1924**

# Part 4

# All According to Plan

**The *Sydney Harbour Bridge: Report on Tenders*, included a detailed description of the fabrication and erection methods to be used should that tender be selected as the winner. As such, Dorman Long & Company's winning tender included a detailed description of the steel fabricating facilities (workshops) it intended to erect at Milsons Point (to supplement their other native facilities). It also included text and drawings of the seven "stages" by which the approaches, anchor cables/tunnel, erection of the arch and hanging of the deck would be accomplished.**

## Erection.

The arch will be erected as two principal cantilevers built out from either shore.

**Stage 1.**—After the necessary excavation has been performed and approach piers constructed, the first step in the scheme of erection will be the construction of sufficient of the abutment towers to support the decking next the end posts of the main arch, and of the approach trusses, beginning with those adjacent to the main span. These spans will be erected on full timber stages with cranes travelling on special tracks laid on the stage (*Plan No. 13, Photograph No. 15*), and the work will proceed until the end of the approach spans is reached.



PLAN No. 13.

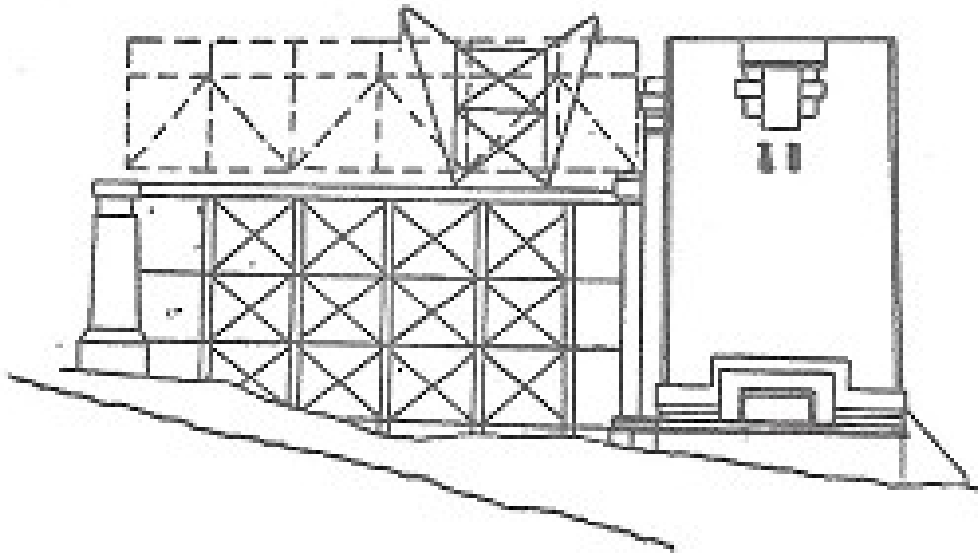

*SIDE ELEVATION*

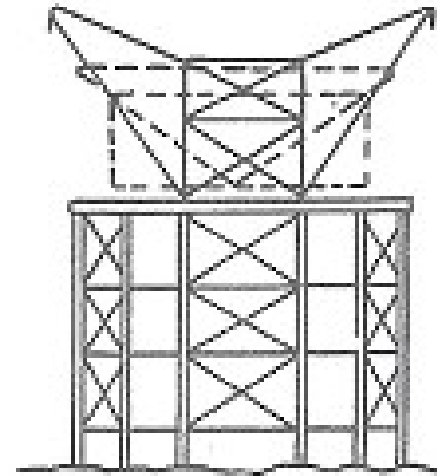

*END ELEVATION*

STAGE I

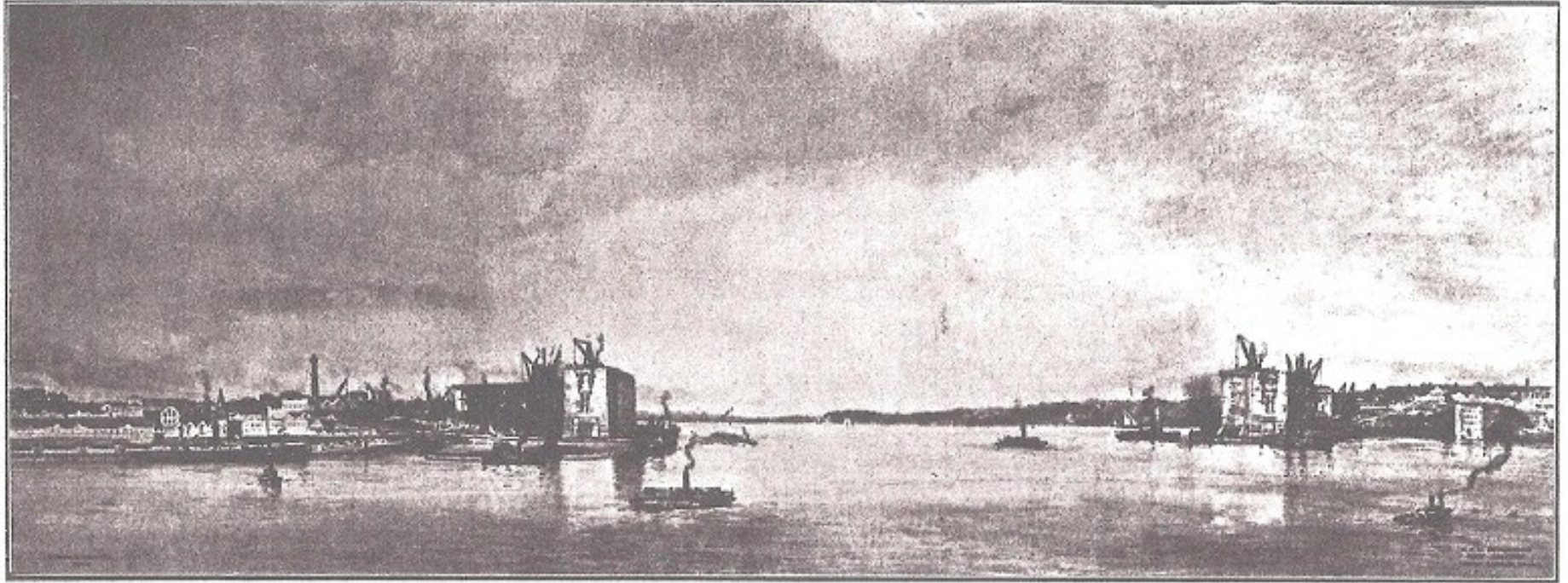

Photograph No. 15.—Stage 1.

**Stage 2.**—On the deck of the bridge so constructed a stage will be built up, the top surface corresponding with the level and plane of the top chord of the arch. On this stage the main erection cranes, shown in Plan No. 14, will be constructed in a position ready for erecting the end post and first panel of the bridge. (*Photograph No. 16.*) These cranes, each weighing 536 tons, have been specially designed for the erection of this bridge, and will be capable of lifting members up to 160 tons weight. In this position the cranes will erect the bearings, end post, and first panel complete. As soon as the end post is in position it will be anchored back to the solid rock by means of steel wire cables.

For anchoring the structure to the rock, tunnels will be driven in a position approximately below the second pier of the approach spans from the main arch bearing. These tunnels will consist of two inclined shafts corresponding to the lines of cables 140 feet apart, but so arranged as to put a definite pressure on the rock where the cable leaves the ground level. (*Plan No. 15.*) These shafts will be approximately 10 feet by 6 feet, and will be connected by two semi-circular cross-tunnels. The cross-tunnels will be sunk to a depth of approximately 120 feet below ground level, depending upon the character of the rock as revealed by the sinking of the shafts. The minimum factor of safety produced on this method is  $3\frac{1}{2}$ , and will obtain just before the two arms of the arch meet at the crown.

The cables passing into the tunnels will be composed of twisted steel wire terminating just above ground level in U-bolt sockets for connecting to the length of anchor cable from ground line to the bridge structure. This connection serves also for adjustment of length. The lengths of cables from the ground to the point of attachment to the trusses will be composed of parallel wire strands wound round cast steel reels forming the terminals at each end of each length. For the first stage of the erection these lengths of cable will be of twisted wire, attached to the tops of the end posts.

Adjustment of the length of cable is performed by means of the U-bolt shackles shown on Plan No. 15, by means of which equality of stress condition can be verified by eye from the sag of the various cables.

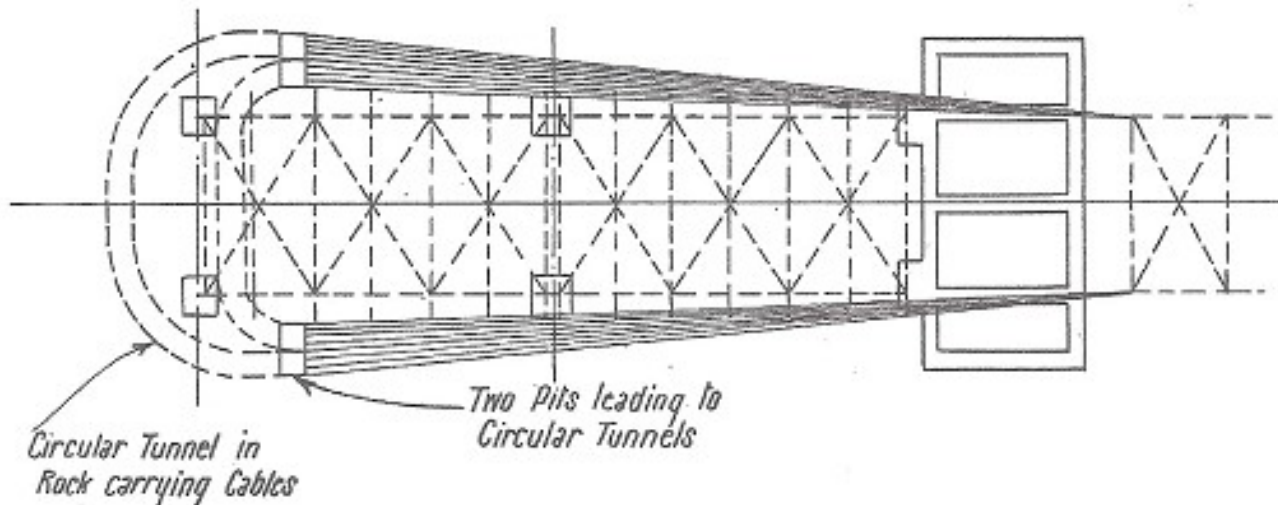
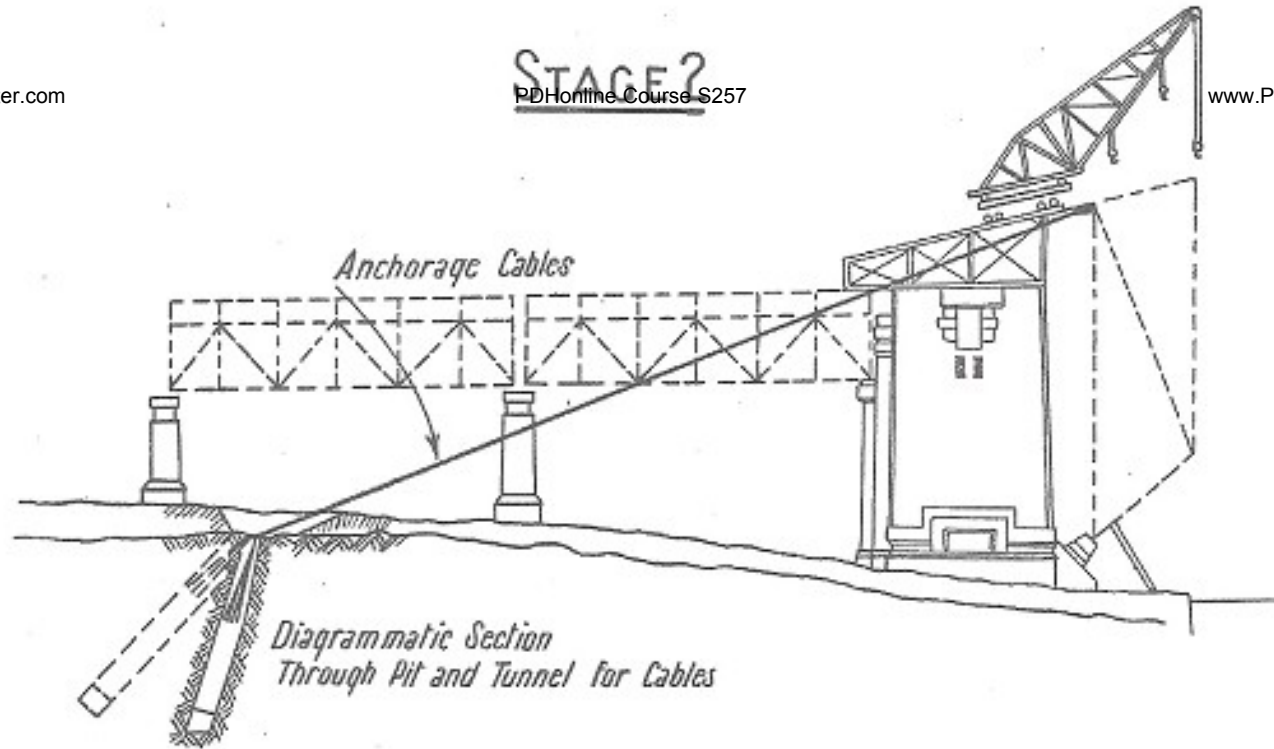

PLAN



# DETAIL OF STAGE 2

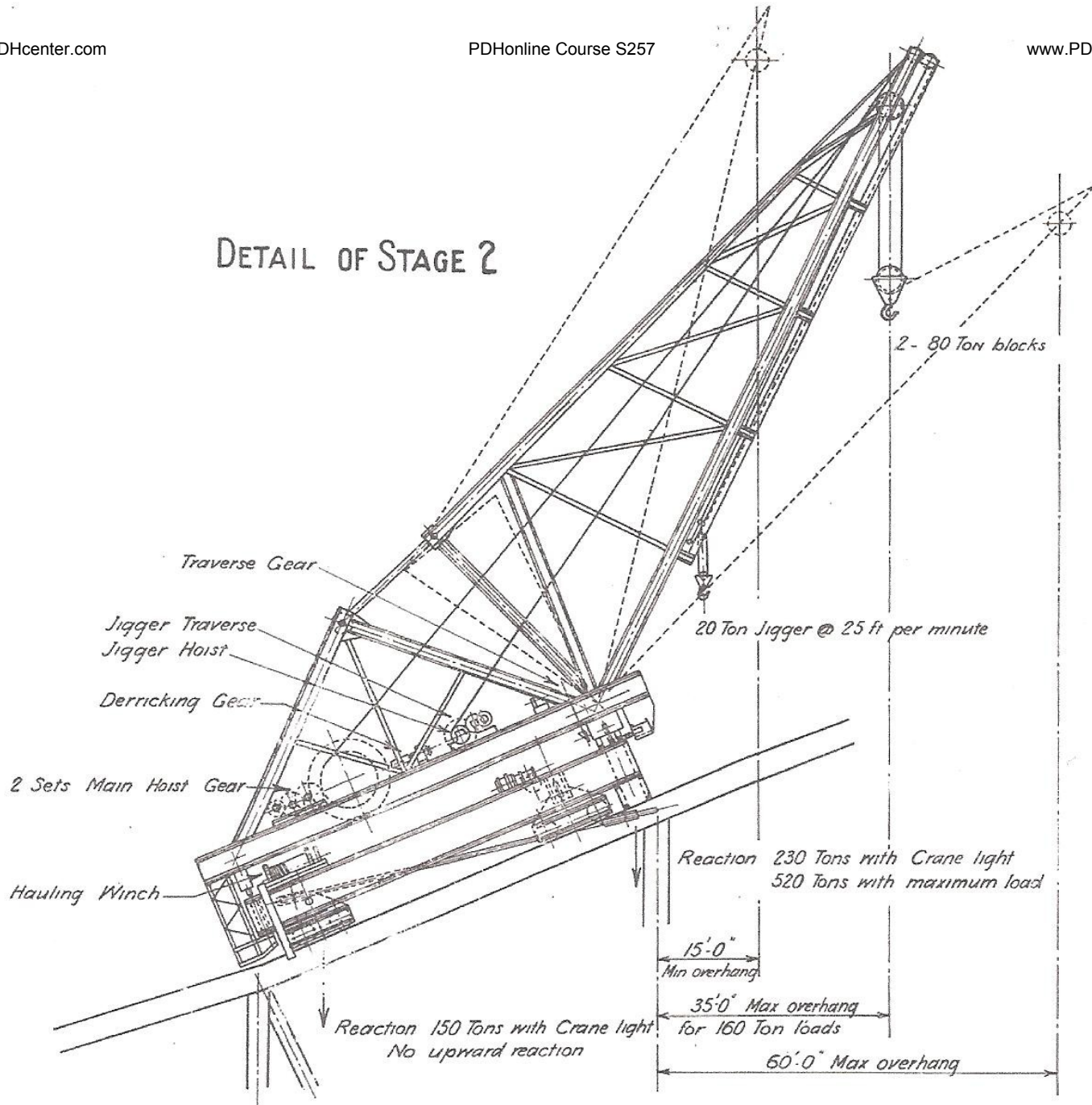



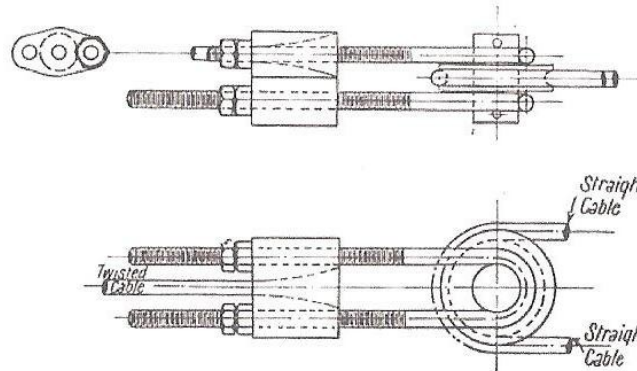
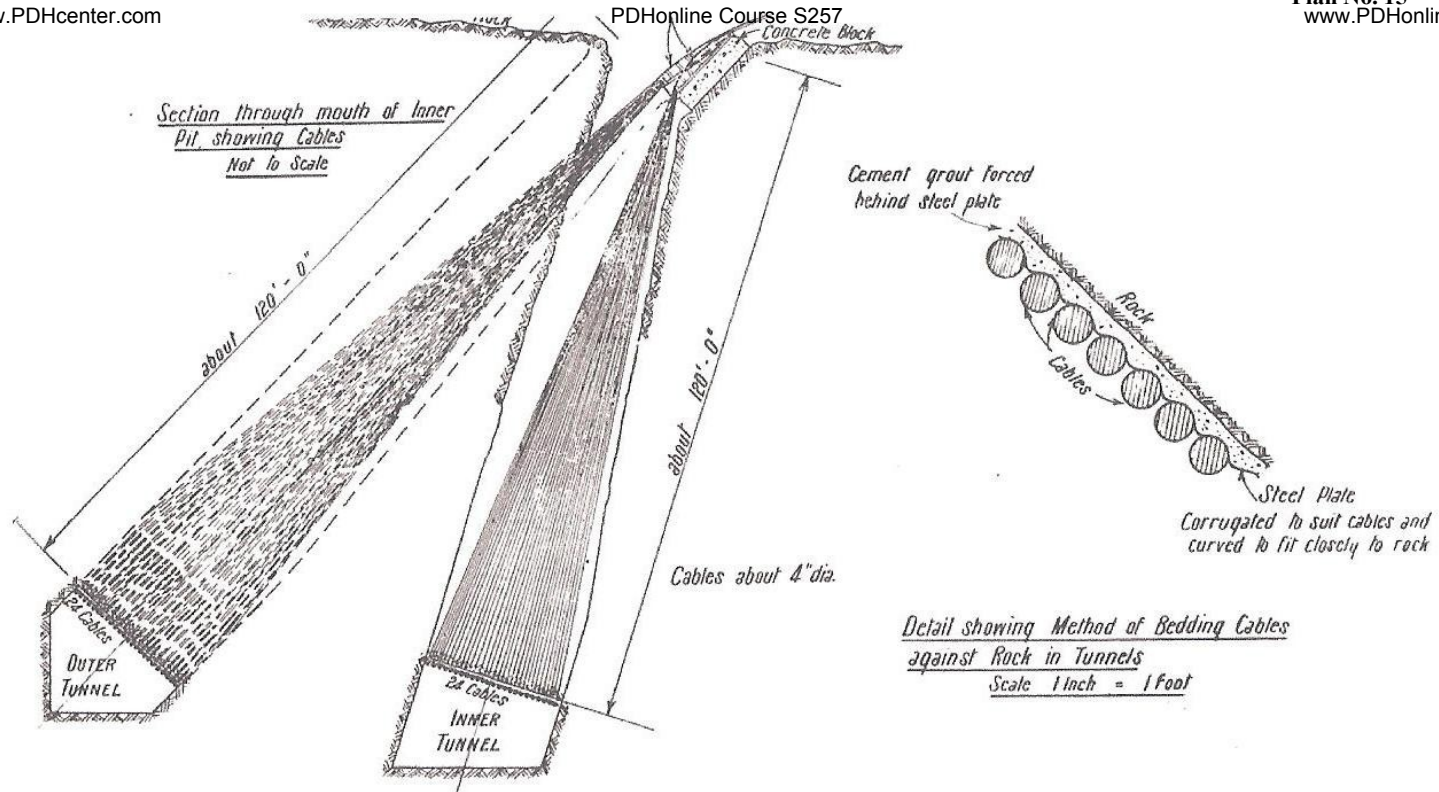

DETAIL OF SHACKLES

Scale : 1/2 Inch = 1 Foot

DETAIL OF STAGE 2



Photograph No. 16.—Stage 2.



**Stage 3.**—On completion of the first panel of the bridge the erection crane will be moved forward on the top chords of the bridge, the overturning moment due to the weight of the first panel and of the crane being taken by the anchorage cable.

In this position the crane will erect the second panel, the anchorage cables being increased from time to time to provide the necessary reaction. This process will be continued until the crane reaches the fifth panel.

Immediately behind the fifth panel, a further series of cables will be secured so as to transfer the reaction from the end post to this panel point. (*Plan No. 16, Photograph No. 17.*) Special gussets supporting anchorage pins will be constructed at this panel point, to which the straight wire cables will be attached. In order to reduce the stress in this second series of cables they will be carried over struts standing on top of the end posts of the arch, the strut supporting cast steel saddles carrying the cables in two groups superimposed on one another. (*Plan No. 17.*) Another strut supported on hydraulic jacks at ground level serves for final adjustment of the completed half-arches.

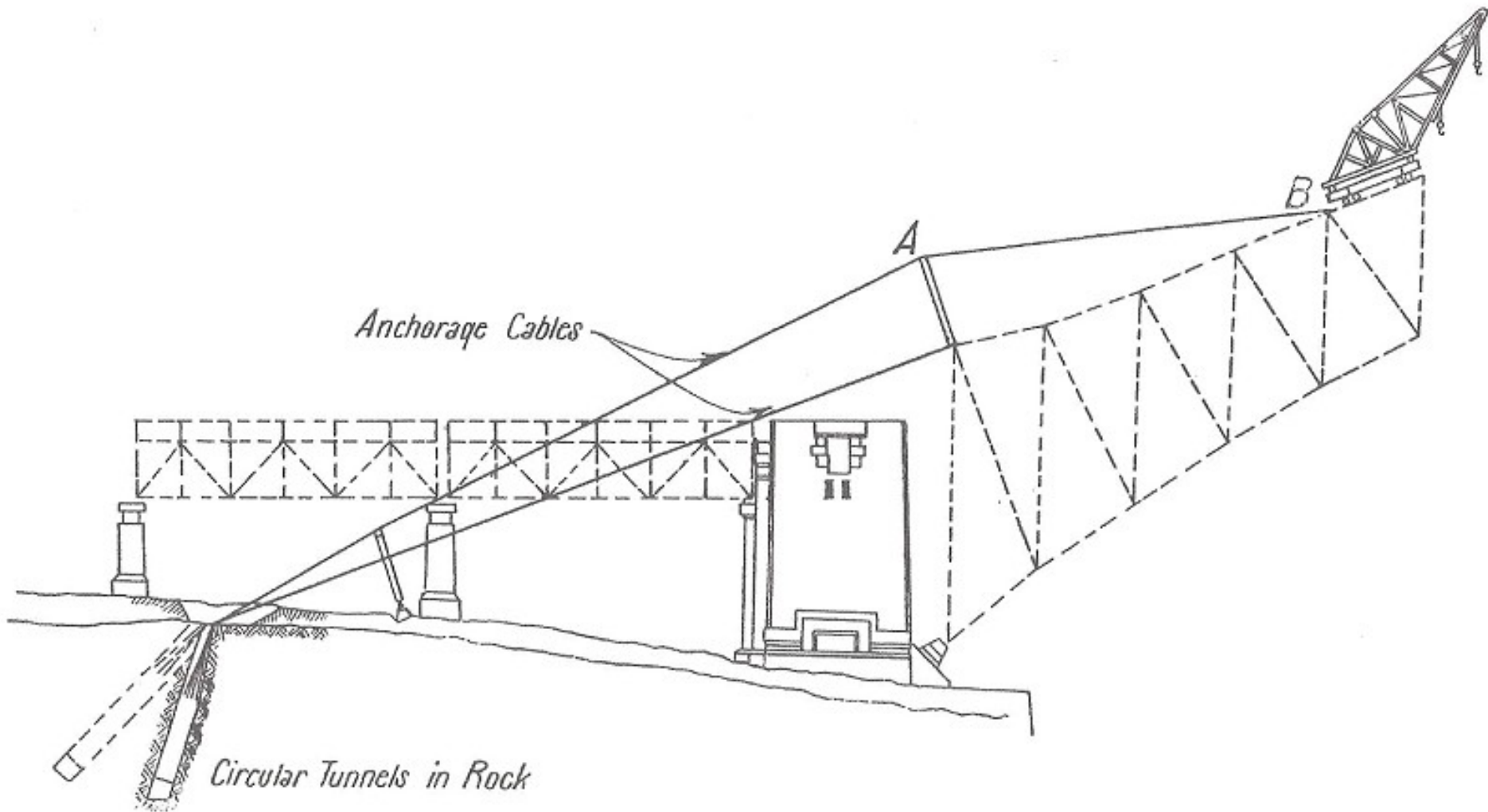

STAGE 3

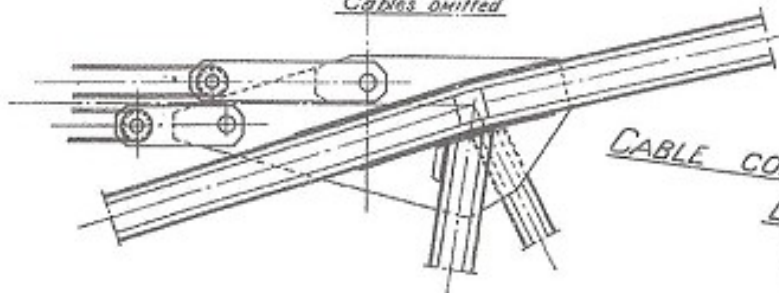
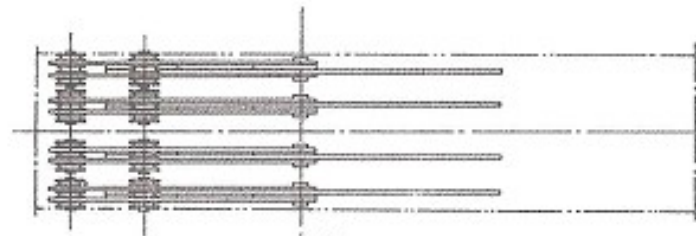
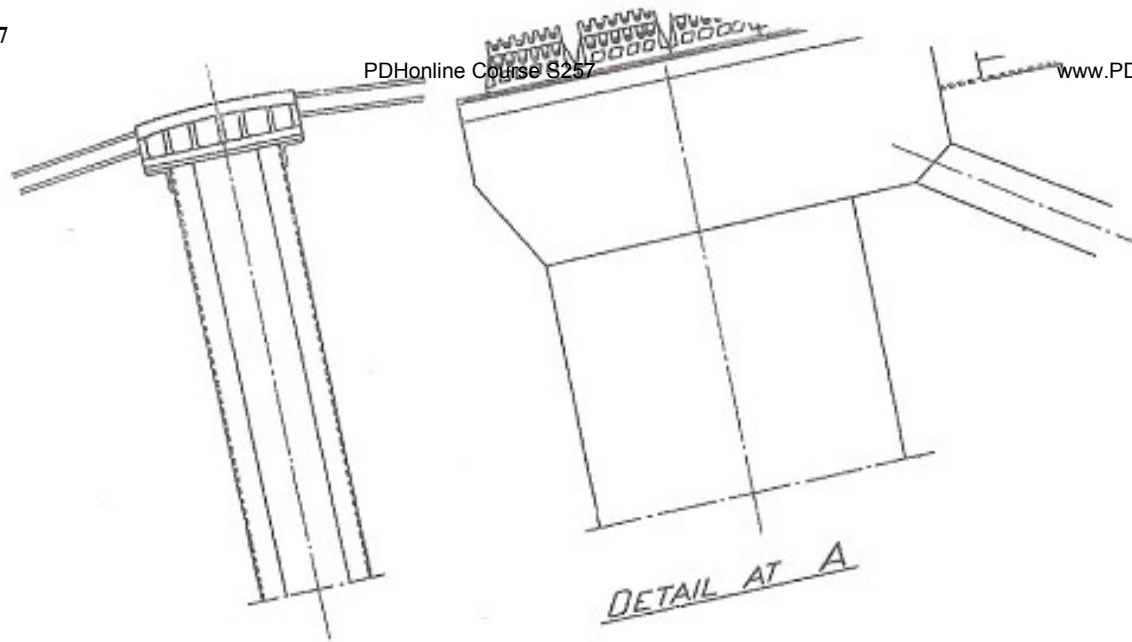

Scale 1/4" = 1'-0"

DETAIL OF STAGE 3



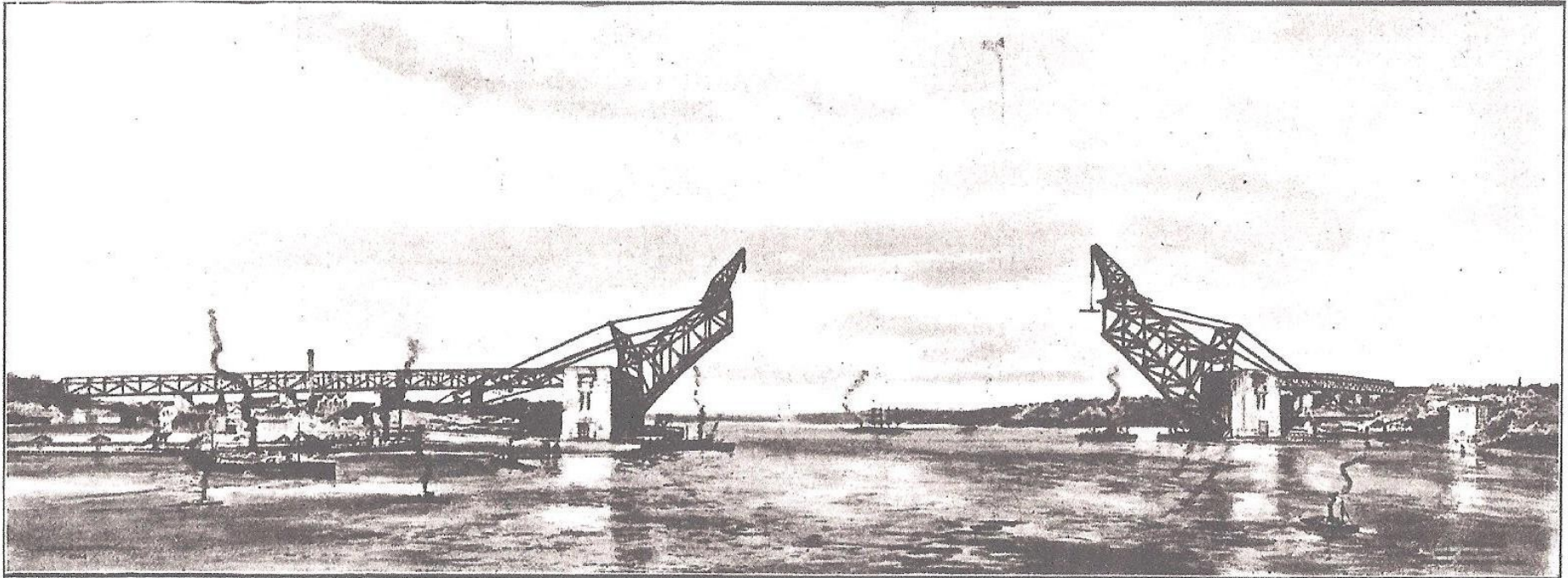

Photograph No. 17.—Stage 3.

**Stage 4.**—As soon as sufficient cable is provided to sustain the reaction, the cables secured to the end post will be slacked, and these cables will then be available for augmenting the cables attached to the fifth panel as the reaction increases due to the moving forward of the crane. The crane will continue to erect successive panels until the tenth panel from the end post is reached, leaving four panels on each side of the centre line to be erected. (*Plan No. 18, Photograph No. 18.*)

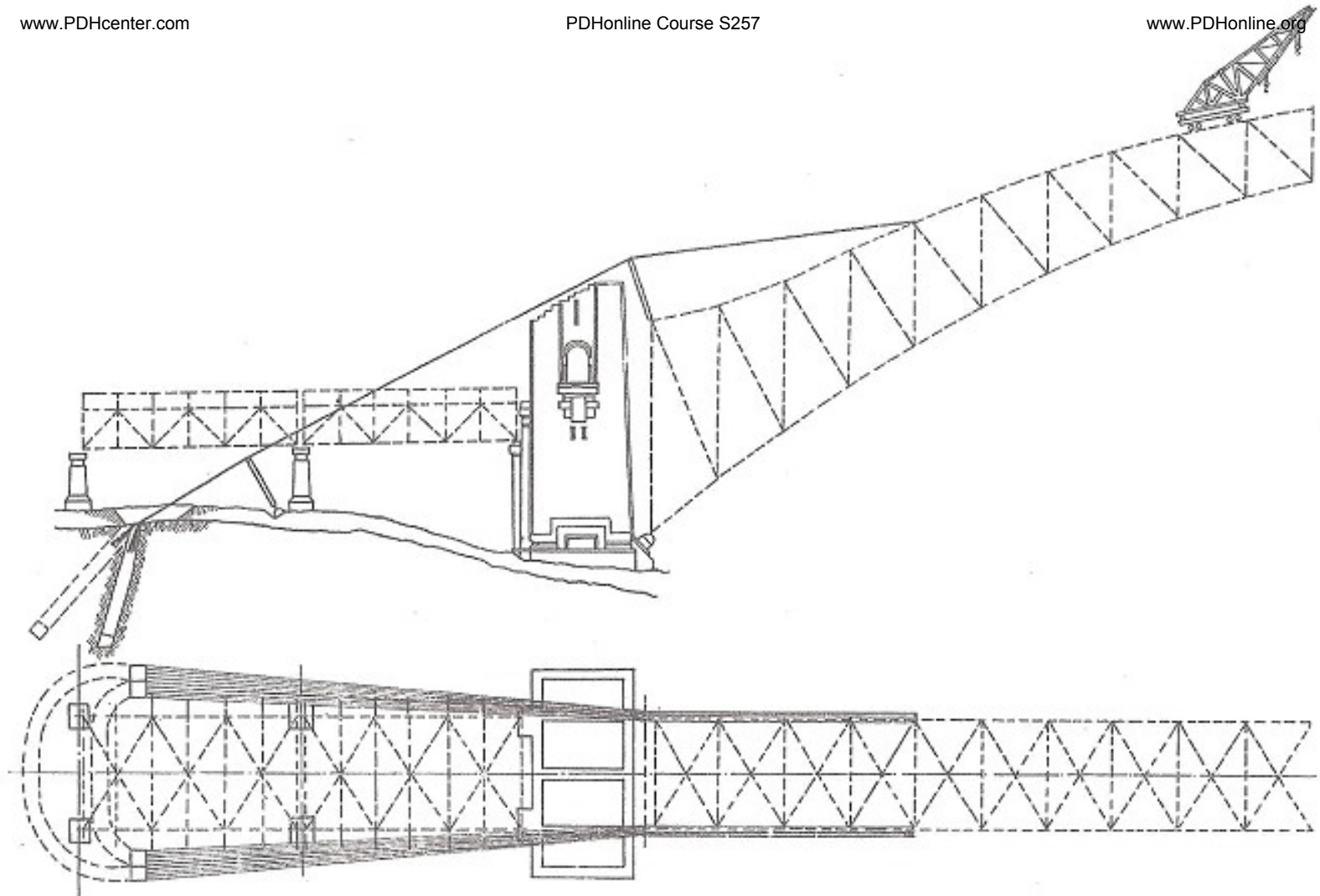

*PLAN*

STAGE 4



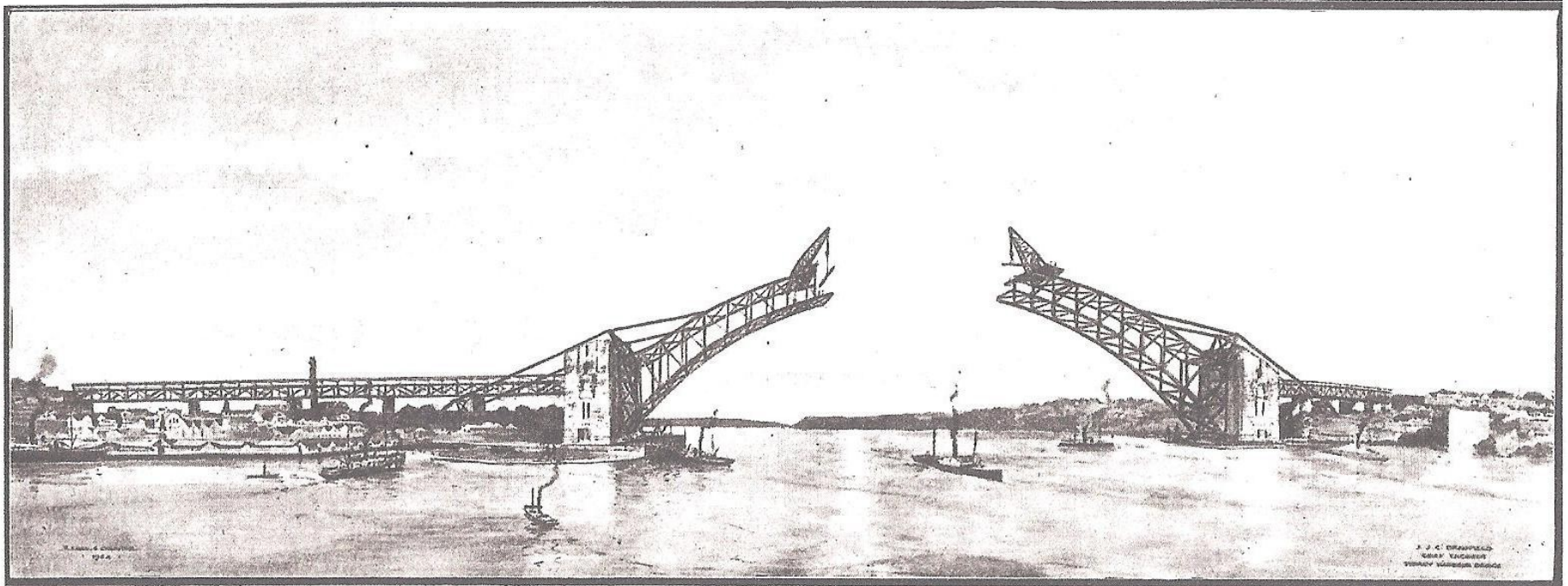

Photograph No. 18.—Stage 4.

**Stage 5.**—As in Plan No. 19, Photograph No. 19, the remaining panels will be erected by means of a lighter crane, shown in Plan No. 20, its total weight being only about 180 tons. This crane will be used in the same manner as that already described for erecting the other panels of the bridge. The half-arches will be finally adjusted in level and allowed to come together by means of hydraulic rams on the struts supporting the cables just above ground level. These jacks will be provided with collar packings in short lengths so that the pressure is normally on the collars, and it will be necessary only to exert a pressure sufficient to permit the removal of a section of the collar packing. The jacks will then be used only to lower the cables and allow the two half-arches to meet. As they do, the tension in the cables will be relieved. In this condition the arch will be complete as a three-hinged arch under the dead load of the main trusses and bracing.



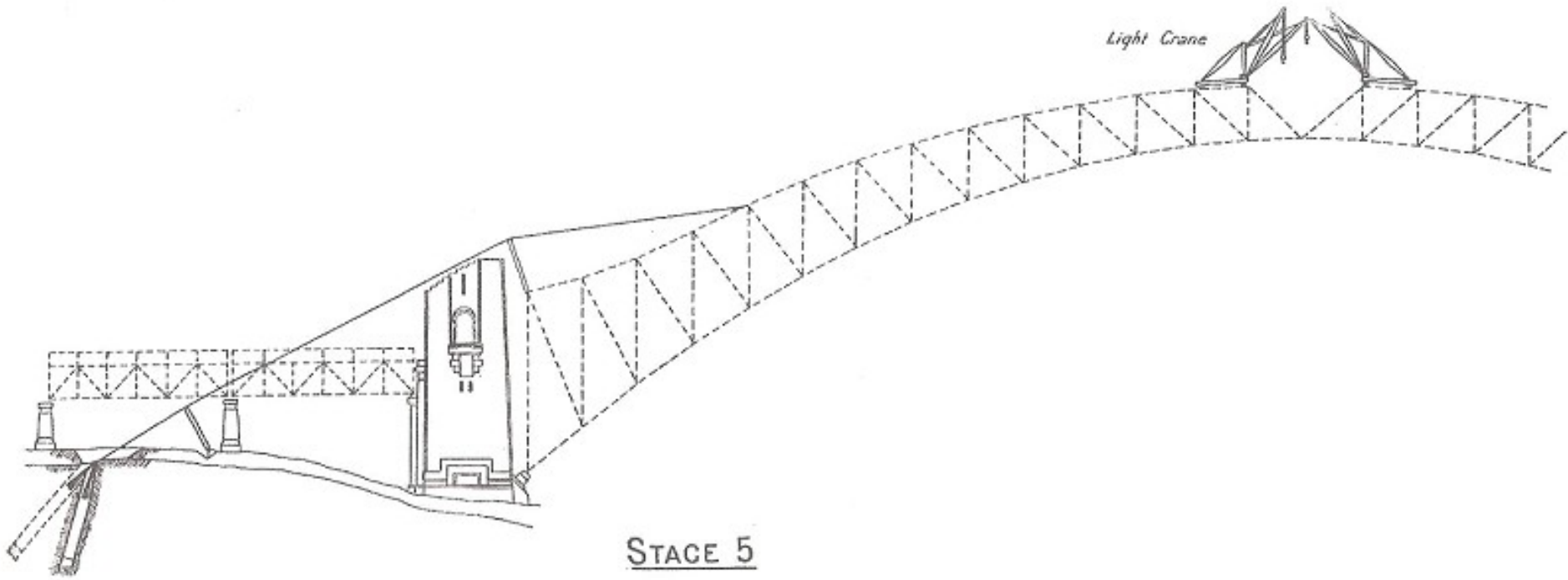

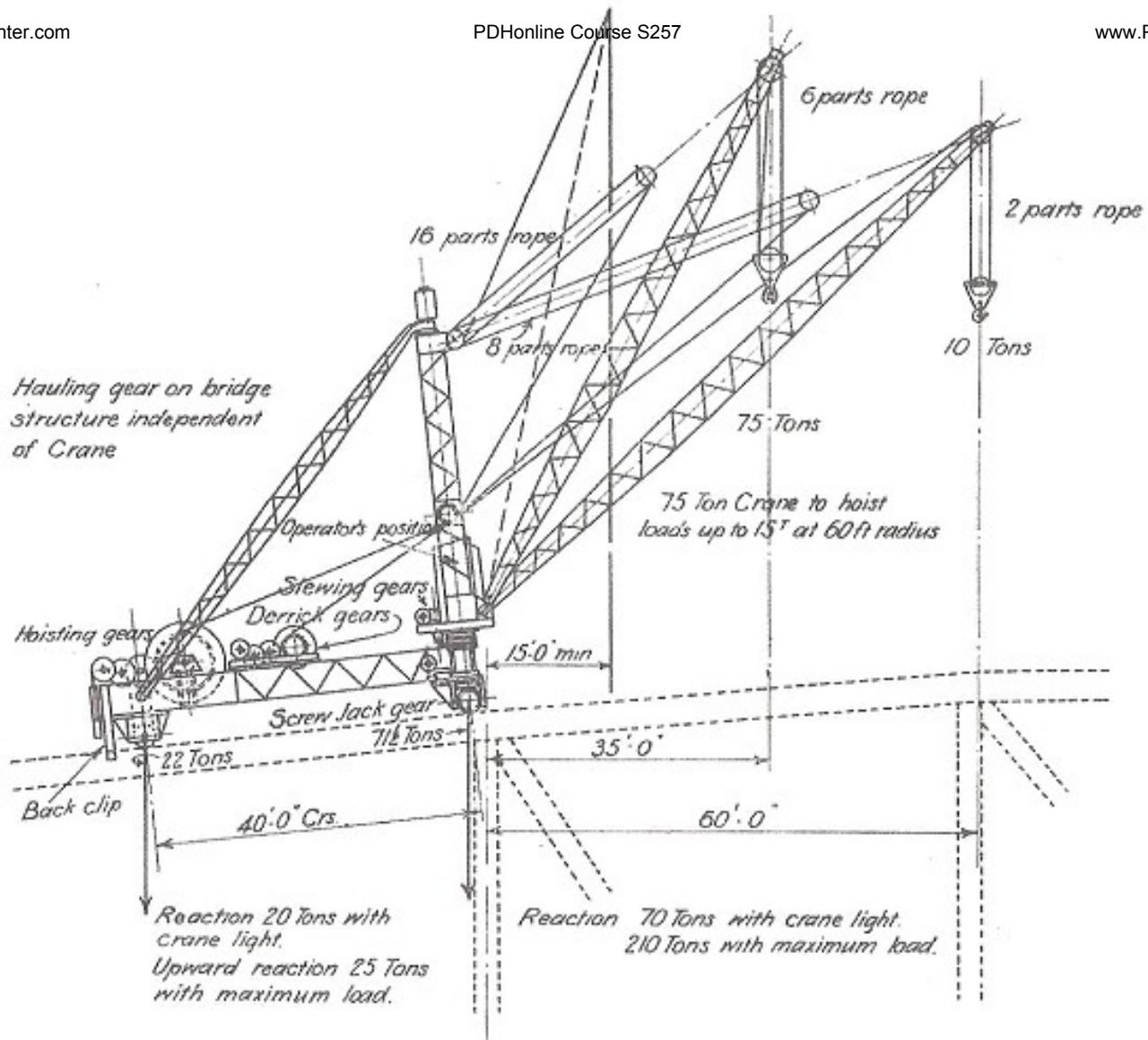

DETAIL OF STAGE 5

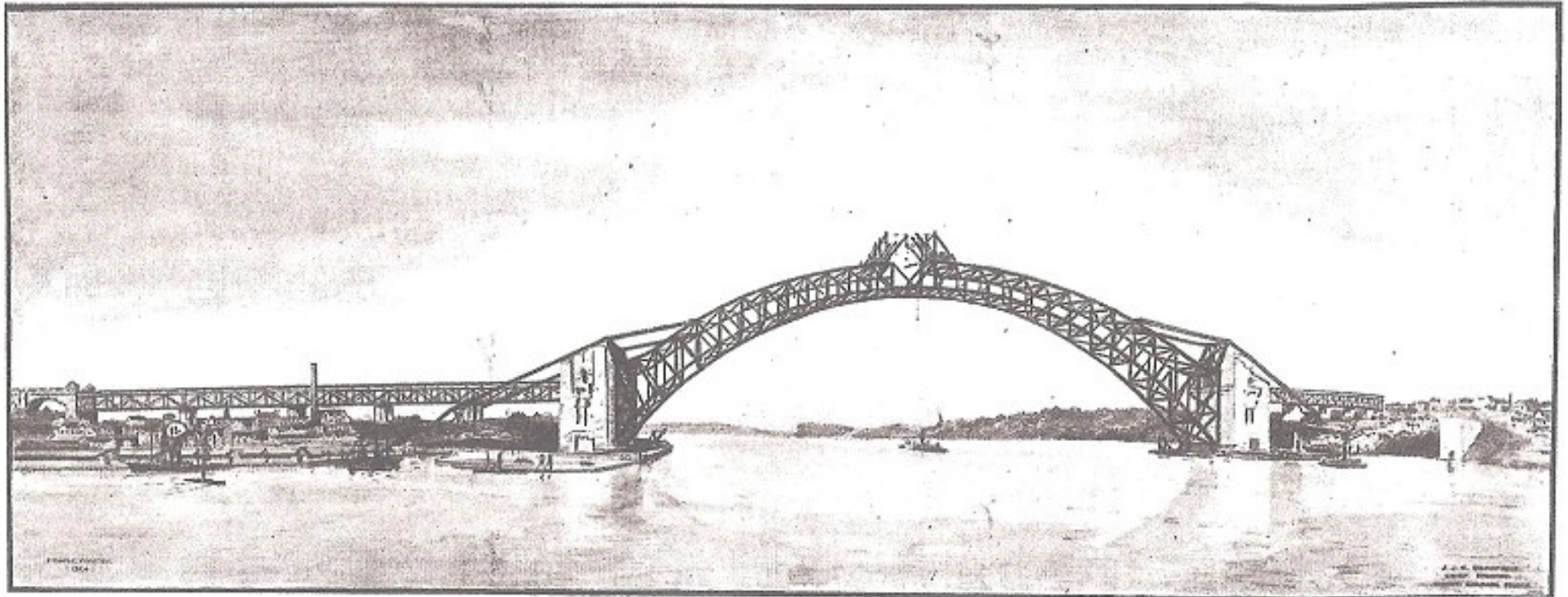

Photograph No. 19.—Stage 5.

**Stage 6.**—(*Plan No. 21, Photograph No. 20*).—Hydraulic rams will then be inserted in the top chord members and an initial stress will be put into the members to correspond with the stress which would arise in these members if the arch were built as a complete elastic two-hinged structure of the correct calculated lengths for all members. The total stress required in the top chord is 4,900,000 lb.





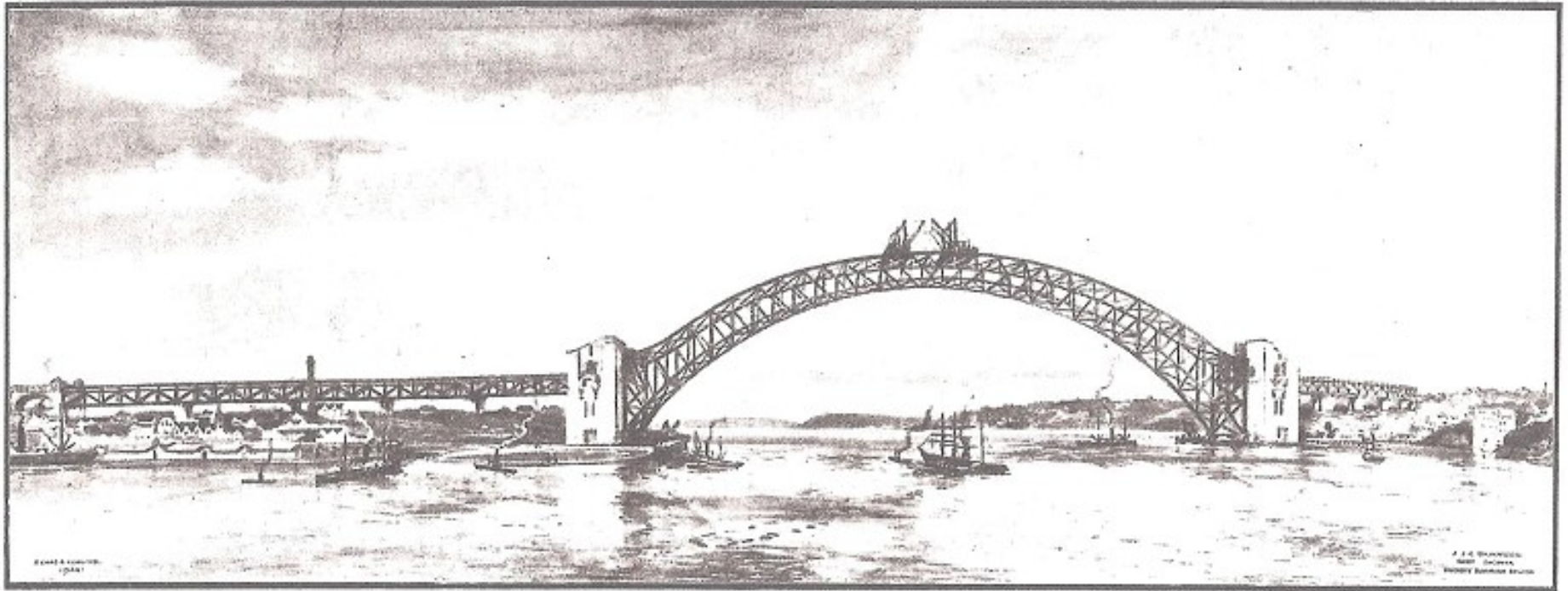

Photograph No. 20.—Stage 6.

**Stage 7.**—(*Plan No. 22, Photograph No. 21*).—After the main trusses have been completely erected, the erection of the floor will proceed simultaneously and symmetrically at both ends by fixing in position the hangers, main cross-girders, stringers, and the necessary finish to the floor. Abutment pylons will then be completed.

PLAN No. 22.

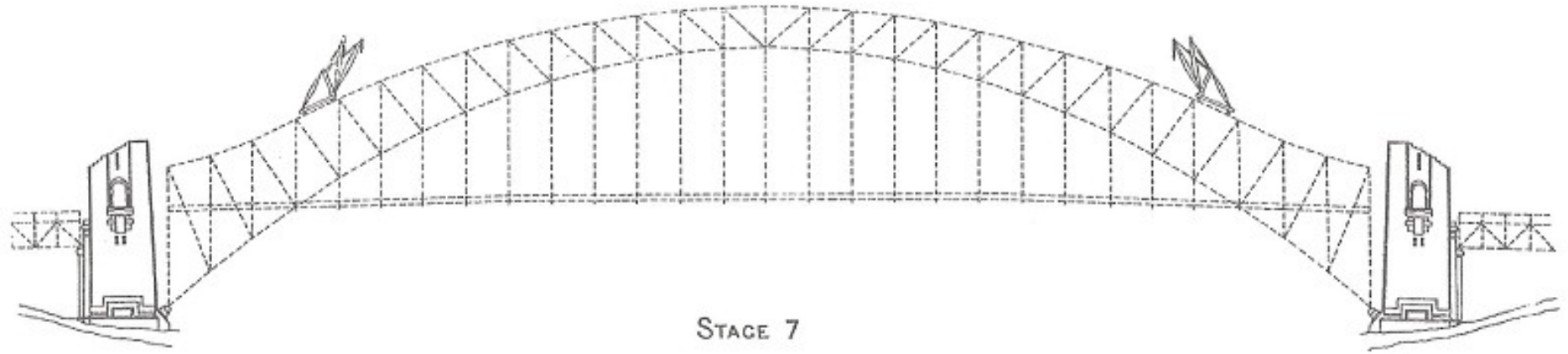

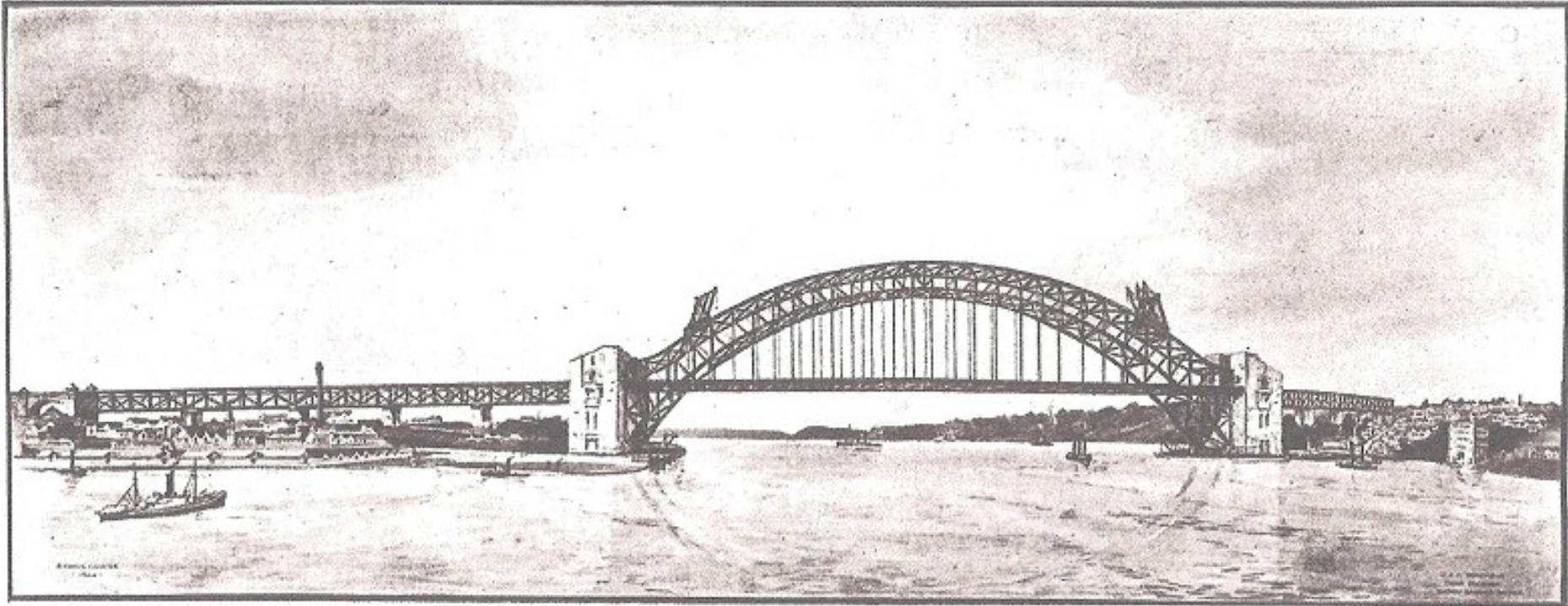

Photograph No. 21.—Stage 7.

# Part 5

# First Things First



## 9.—Description, Fabrication and Erection of the Two-hinged Arch Bridge Recommended.

The two-hinged arch bridge, in accordance with the official specification and plans, comprises a two-hinged main arch span from Dawes' Point to Milson's Point, a distance of 1,650 feet, centre to centre of bearings, with five deck approach spans on either side of the harbour. The overall length of the bridge is 3,770 feet.

**RE: excerpt from: *Sydney Harbour Bridge: Report on Tenders***

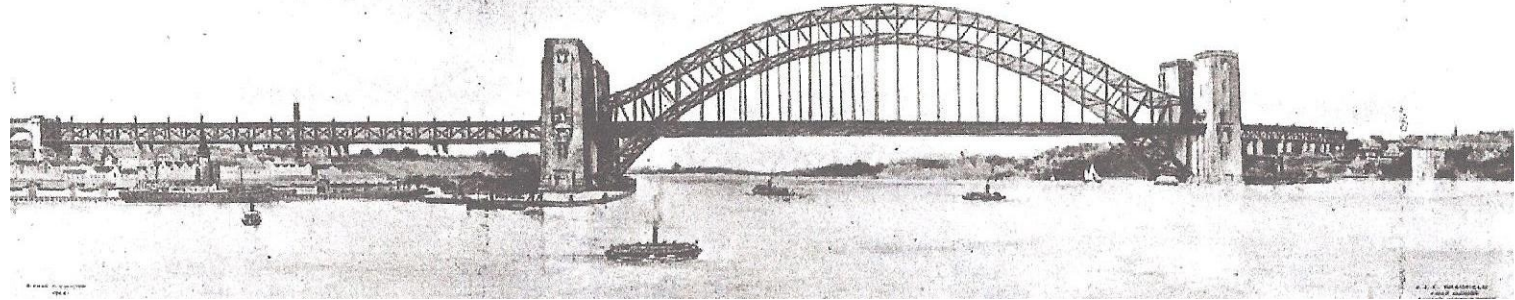

*“...The design of the bridge provided for a single great central arch of 1,650-feet span, crossing Sydney Harbour from north to south in a single stride, and rising at its centre to a height of 440-feet. From this, the trackway was suspended at a mean height of 170-feet above sea-level, passing off the arch at either end on to a series of five approach spans, formed of horizontal girder structures on granite piers...”*

*Wonders of World Engineering, 1938*



*“Engineering encompasses  
the utility of material things  
with the beauty of spiritual  
things”*

**JJC Bradfield, 1924**

**The Sydney Harbor Bridge was to be the tallest structure in Australia and, at 50K-tons, the heaviest bridge ever built. The steel sections and even the rivets would be the largest ever produced for a bridge project. Navigation of the channel could not be impeded in any way and, in any event, the depth of the channel barred temporary support for the incomplete arches from below. To prevent the arches from rotating on their hinges during construction, 128 wire-ropes (anchor cables) would hold back each side of the double-arch from the top-chord via U-shaped tunnels (on each side). Once the arch was complete, the tension in the belt of wire cables would be relieved and cables removed thus allowing the pylon/s to be completed. The four enormous hinge-bearings (weighing 300-tons each) embedded in concrete abutments (dug into Sydney's native sandstone) were most critical since it would be through these that the thrust (compression load) of the arches would be transferred into and absorbed by the earth. Segmented sections of steel form the arch (at a slight angle) with an allowable tolerance of 4/1000ths of an inch (13mm).**

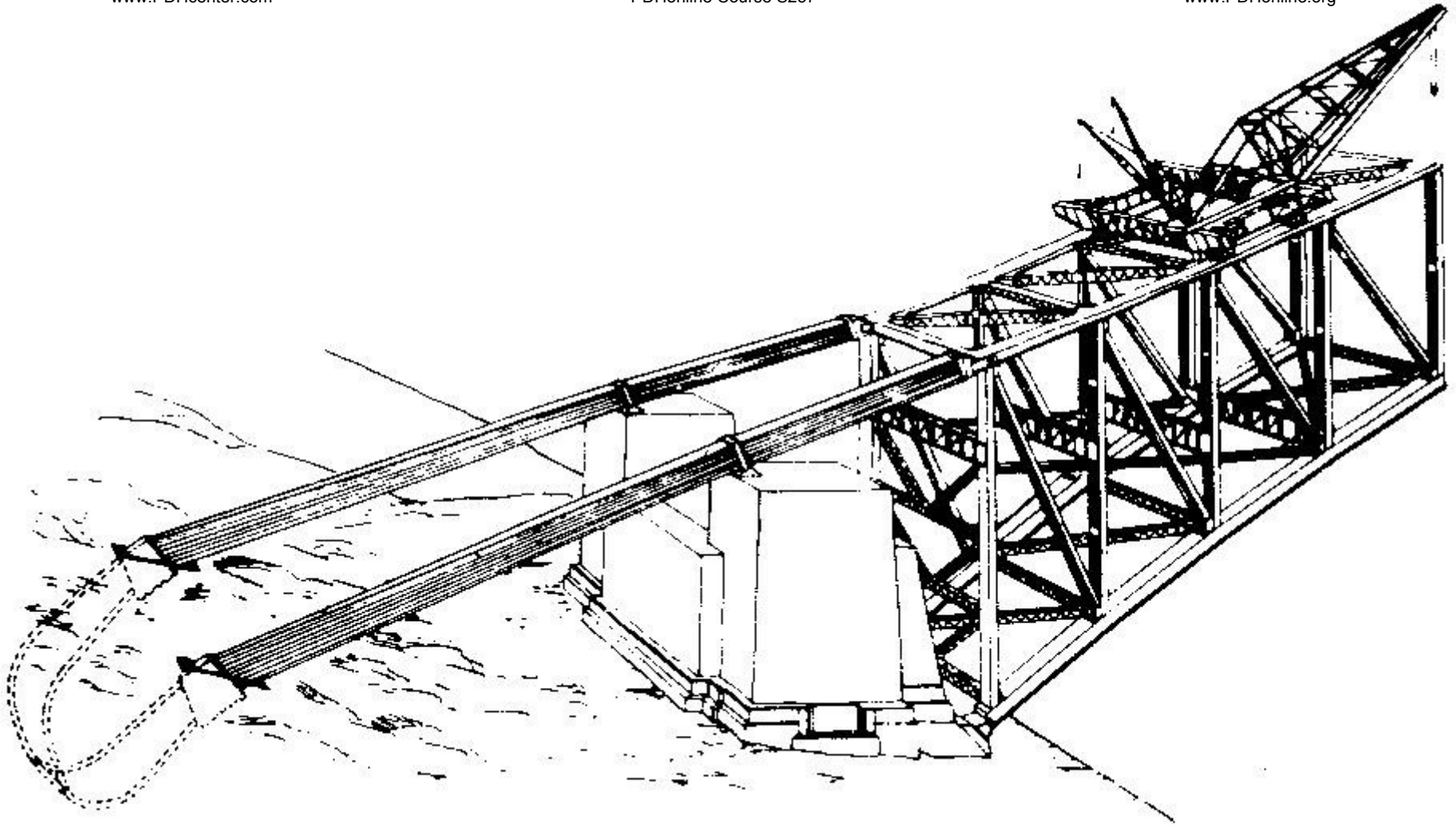

## Anchor Cables

(restraining the half-arch from rotating on its hinges) 149



*“...the total thrust to be sustained by the four bearings under live-load conditions is no less than 78,800 tons...the thrust of the main arch below the main bearings is at an angle of 45-degrees”*

**Lawrence Ennis – Director of Construction, SHB**



## Hinge-bearing/Skewback



## **Segmented (spliced) lower chord**

**The national Australian earthquake code did not come into existence until 1978 thus, there is no provision in the SHB design specifications for resistance to seismic forces. At the time, it was a common belief among engineers that, if a structure could withstand the extreme wind loads for which they are designed, they could easily withstand ground motion caused by seismic events. This belief was/is erroneous since seismic forces can be up to 10x stronger than the dynamic force of the wind on a structure.**





## Setting of Foundation Stone March 25, 1925



# ABUTMENTS

...The abutments are of concrete with granite aggregate and faced with granite above ground level, being built up from a level of 25 feet below top rock level, and the inclined skewbacks are capped with granite accurately dressed to take the heavy silicon steel pedestals which carry the main pins. This pedestal is built in three tiers comprising two grillages each 4 feet deep, with lower base plates  $2\frac{3}{4}$  inches thick in six portions, making a total area of 22 feet by 17 feet 6 inches or 385 square feet, supporting an upper pedestal 8 feet 5 inches high, which bears on the main pin. The upper grillage is composed of solid bars of silicon steel, each 6 inches thick and the lower grillage of 12 bars each 5 inches thick. Each main pin is divided longitudinally into halves, and is 10 feet long and 52 inches in diameter, enclosing a solid key pin 14 inches in diameter, divided into four lengths, one for each web of the lower chord. The whole is covered by a thin steel sheet casing and is kept in position during erection by six holding-down bolts each 4 inches in diameter. The weight of each complete pedestal is approximately 260 tons.

**RE: excerpt from: *Sydney Harbour Bridge: Report on Tenders***

**The superstructure (arch, deck etc.) is supported by four “Skewback” abutments made of strong concrete (two each on either shore). Excavation for each Skewback was made directly into the solid sandstone native to the Sydney shoreline. Each one measures 40-feet wide by 90-feet long by (up to) 40-feet deep (27x12x9-meters). The exposed surface (for the mounting of the pedestal/hinge-bearing/s) is inclined at a 45-degree angle (to absorb the thrust of the arch). The concrete used achieved a strength of 430-tons per square foot (after twenty-eight days of curing). The thrust of each arch truss is transferred from the lower chord (Arch) to the concrete Skewbacks through the steel pedestal/hinge-bearing.**

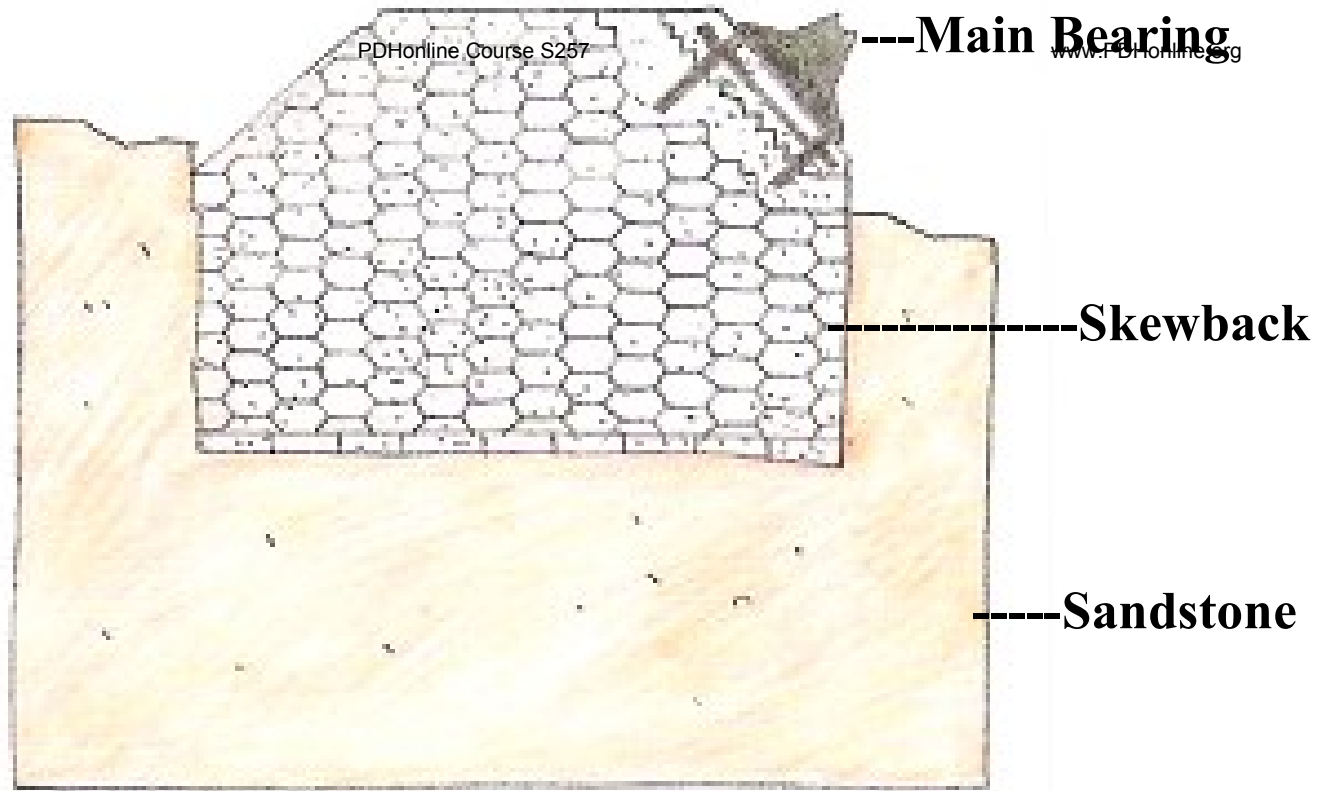

**Formed in concrete, the layer directly below the main bearing is made of Portland cement, Nepean sand and crushed granite. Concrete for the Skewbacks was poured in specially designed hexagonal batches. This was done to help distribute the load from the thrust of the arch into the abutment and sandstone below.**

*“...The precautions to get the bearings into true alignment were extreme. On this depended the success or failure of the whole structure. The pairs of bearings were situated at the corners of an enormous rectangle, the distance between the members being nearly 100-feet, while a third of a mile of water divided one pair from the other. Yet it had to be ensured that the axis of one bearing, if produced, passed exactly through the axis of its neighbour; that the common axis of the northern pair was exactly parallel with that of the southern pair; and that both axes were exactly horizontal, as they would form the only fixed 46 points of reference in the whole structure...”*

*Wonders of World Engineering, 1938*





*“...A fixed mark was therefore set up on either shore midway between the bearing sites; the two marks were connected by triangulation, a base line 1,200-feet long being measured off eastward along the northern shore. Angles to the marks were taken from either end of the base by the theodolite. As a check, a second base line of much the same length as the first, but designedly not run quite parallel with it, was also laid off, and a second triangulation was made. The relative positions and bearings of the two fixed marks having been accurately established, the exact sites of the four bearings were next laid off from these by direct measurement...”*

*Wonders of World Engineering, 1938*

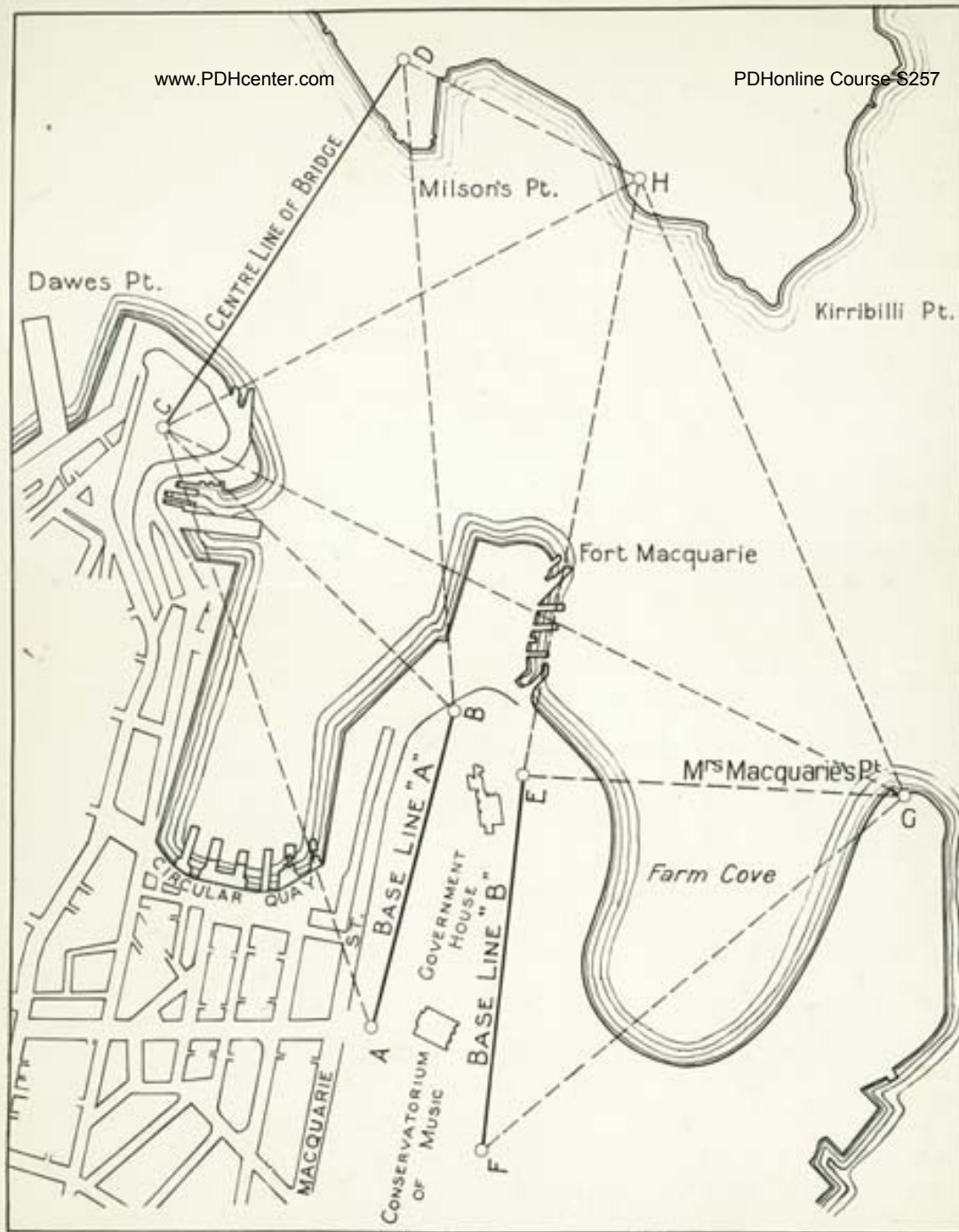

**To precisely fix the centerline of the bridge, two base lines (“A” & “B”) were drawn accurately in the *Conservatorium of Music* and *Government House* grounds. The length of the centerline (C-D) was determined by triangulation from each of the base lines (A-B & E-F) to be 2,268.447-feet. The arch-span of 1,650-feet was thus accurately measured from line C-D.**





**March 17, 1925**  
**Surveyors measuring Base Line “B” (line E-F)**  
**(on the *Conservatorium* grounds)**

***“The angles were read twenty-four times and the mean reading used in the calculation. With this instrument (Theodolite) the error in closing the three angles of a triangle 180-degrees averages  $\frac{1}{4}$  of a second; an error of one second of an arc in a mile (1.61 km) sight would amount to  $\frac{1}{4}$ -inch”***  
**JJC Bradfield – Chief Engineer, SHB**

SYDNEY HARBOUR BRIDGE,  
TRIANGULATION.

www.PDHcenter.com

PDHonline Course S257

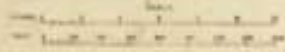

Angle	Dist	Mag	Sec
CAB	51	45	24.432
ABC	109	54	26.707
BCA	28	30	29.660
ACD	27	20	58.278
CDB	40	25	56.685
BCD	43	42	31.280
ADB	42	47	36.450
ABD	33	36	30.982
BCD	87	43	46.836
ACD	44	41	52.147
ADB	34	44	39.543
CDB	40	29	42.327
BCD	36	31	34.225
ACD	34	23	43.573
CDB	29	10	34.042
BCD	55	7	49.735
ADB	30	45	36.883
CDB	47	39	32.294
BCD	43	22	33.185
ACD	29	26	45.001
CDB	40	14	37.534
BCD	41	24	37.455
ADB	37	37	32.047
BCD	39	24	49.647
ACD	25	29	48.029

LENGTHS OF BASE LINES

Base Line X	877.3427	mean value adopted 877.340'
	877.3577	
Base Line Y	195.9552	mean value adopted 195.952'
	195.9605	
Base Line Z	382.384	mean value adopted 382.385'
	382.395	

CALCULATED LENGTH OF CD

Base Line Y using S.D. 2248.434'	Length of CD adopted 2248.45'
S.R. 2248.447'	
Base Line Y using C.H. 2248.460'	Length of CD adopted 2248.45'
S.D. 2248.447'	
Base Line Z	2248.456'

This is the plan accompanying my report of 23<sup>rd</sup> Oct. 1925

J. J. C. Bradfield  
Surveyor.

*“...the length of the centre line across the harbour ‘C-D’ was determined by triangulation from each of these baselines’ to be 2,268.447-feet (691.423m). The length of the arch span (K-L), 1,650-feet (502.92m) was accurately fixed by measurement from ‘C’ and ‘D’”*

**JJC Bradfield –  
Chief Engineer,  
SHB**





*“...To keep the dimensions of the arch as small as possible, the sites selected for the bearings were not more than 50-feet from the waters of the harbour. Special cofferdams having been placed to ensure that no water should find its way into the workings, the sites for the bearings were excavated to a depth of 40-feet over an area 90-feet long and 40-feet wide. On the floor of these pits exploratory holes were then drilled to a further depth of 75-feet...”*

*Wonders of World Engineering,  
1938*

**Excavation for the SW Skewback  
Abutment - April 1926**



*“...The results of these tests was satisfactory, and indicated that the sandstone on which the thrust of the bearings (approximately 13-tons per square foot) would ultimately come was entirely solid, without cracks or fissures. The excavations were then carefully filled up with strong concrete – four parts crushed granite, two parts sand and one part cement...”*

*Wonders of World Engineering, 1938*



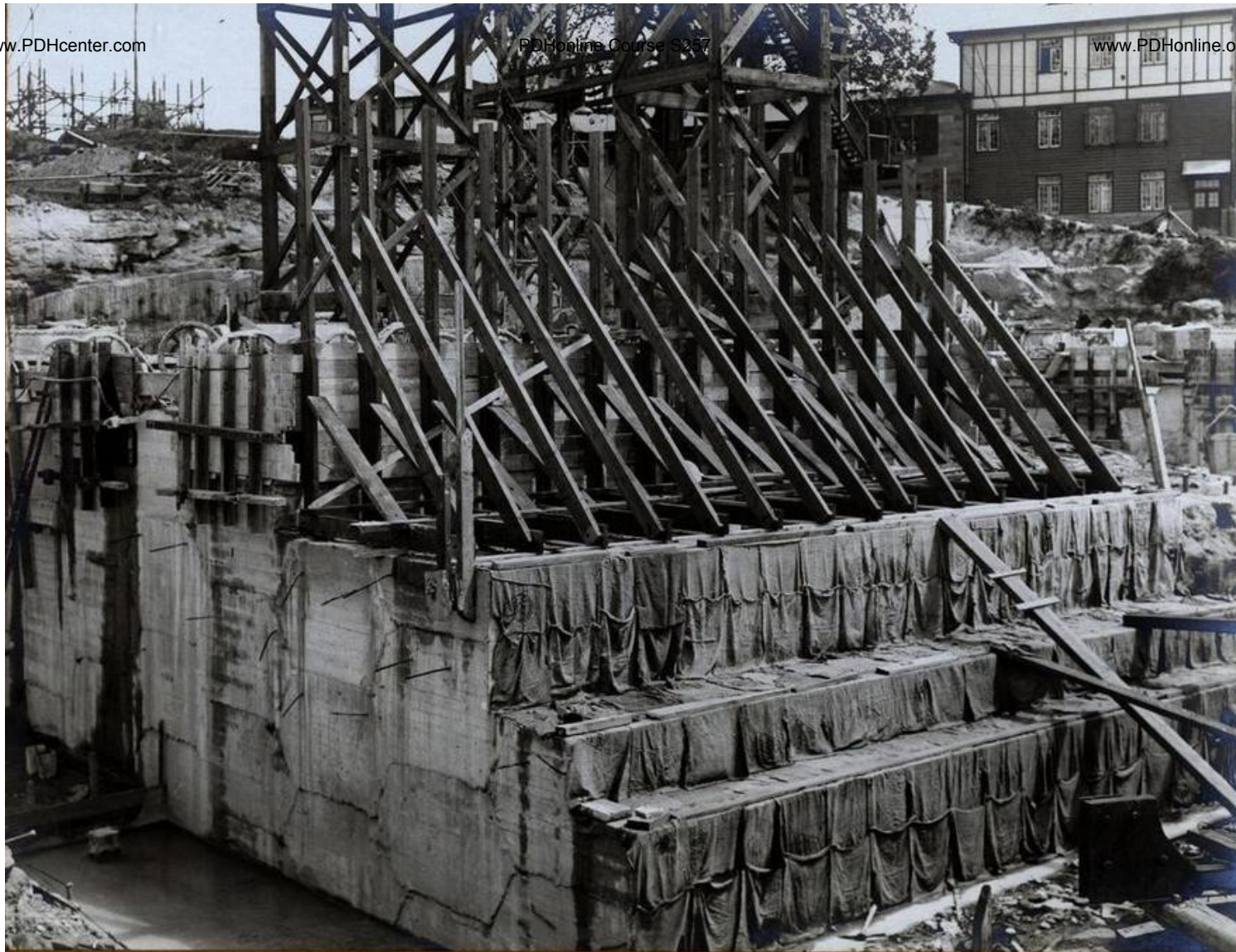

**Skewback concrete stepped to receive special concrete  
(under main hinge-bearing)**

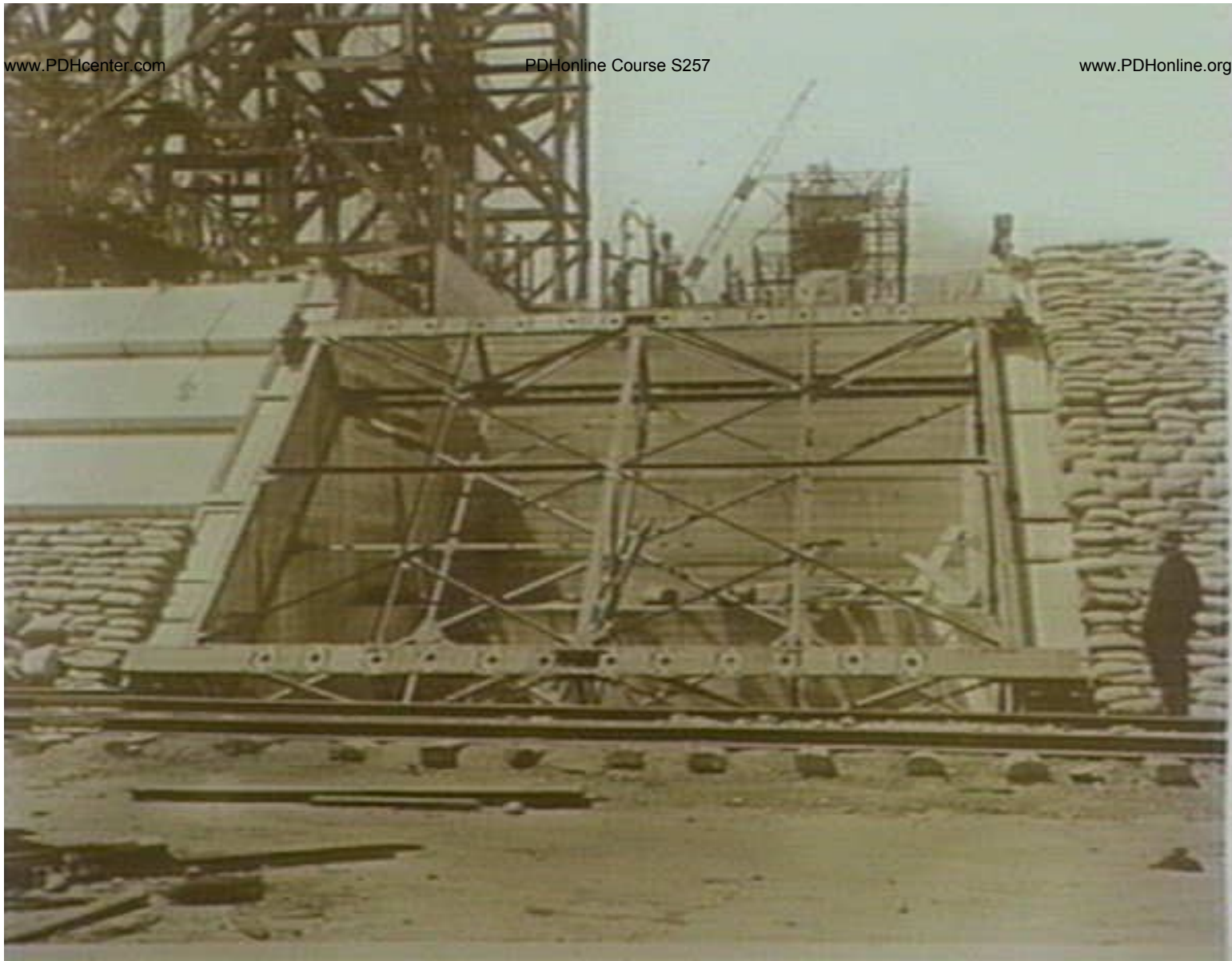

**Temporary steel frame over Skewback  
(to support hinge-bearing during adjustment)** <sup>168</sup>



## **“Setting the Base”**

**Six steel castings bolted together and resting on the face of the Skewback**



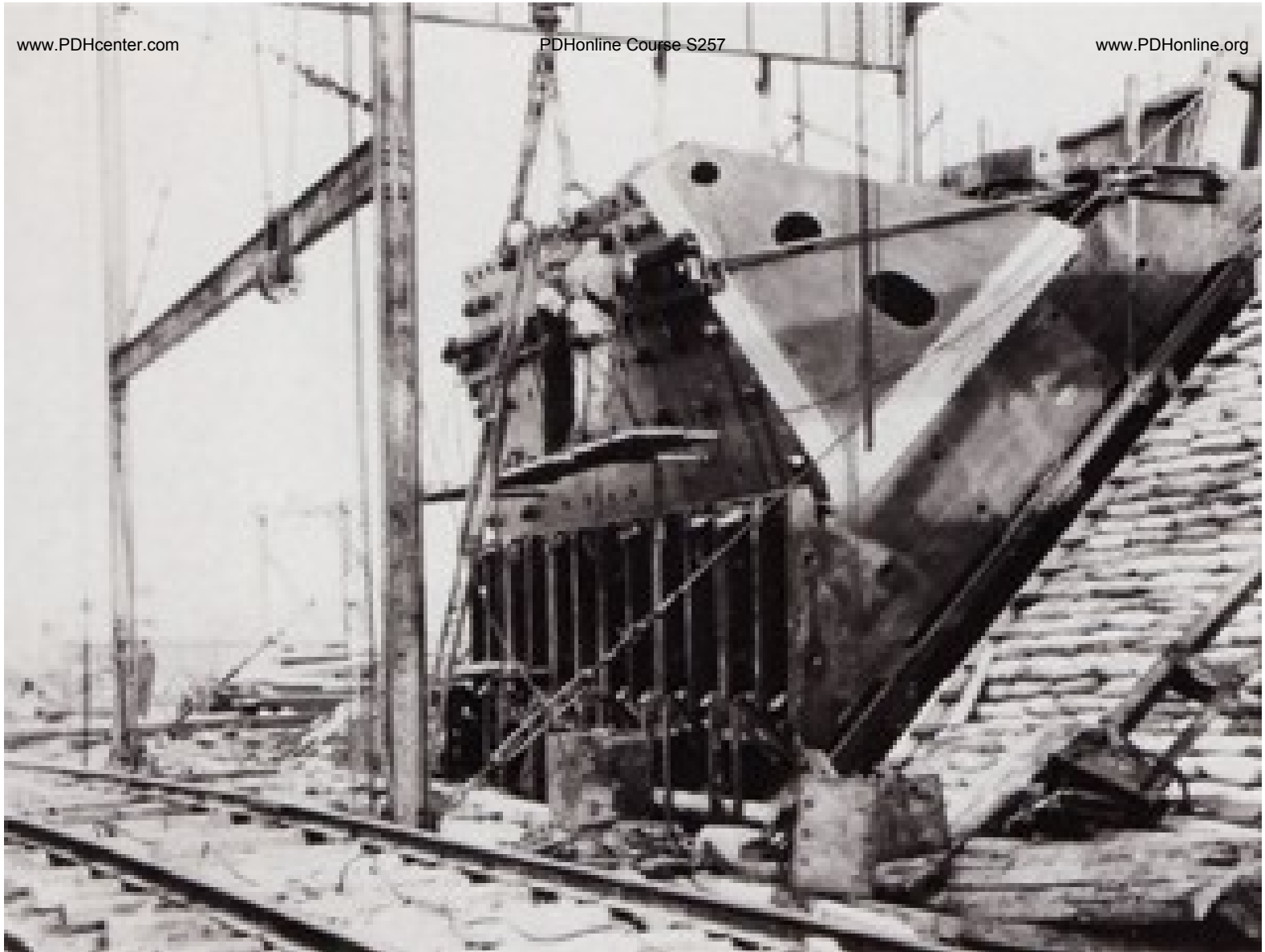

**Pedestal (a.k.a. “Saddle”) secured in place  
(atop Base)**

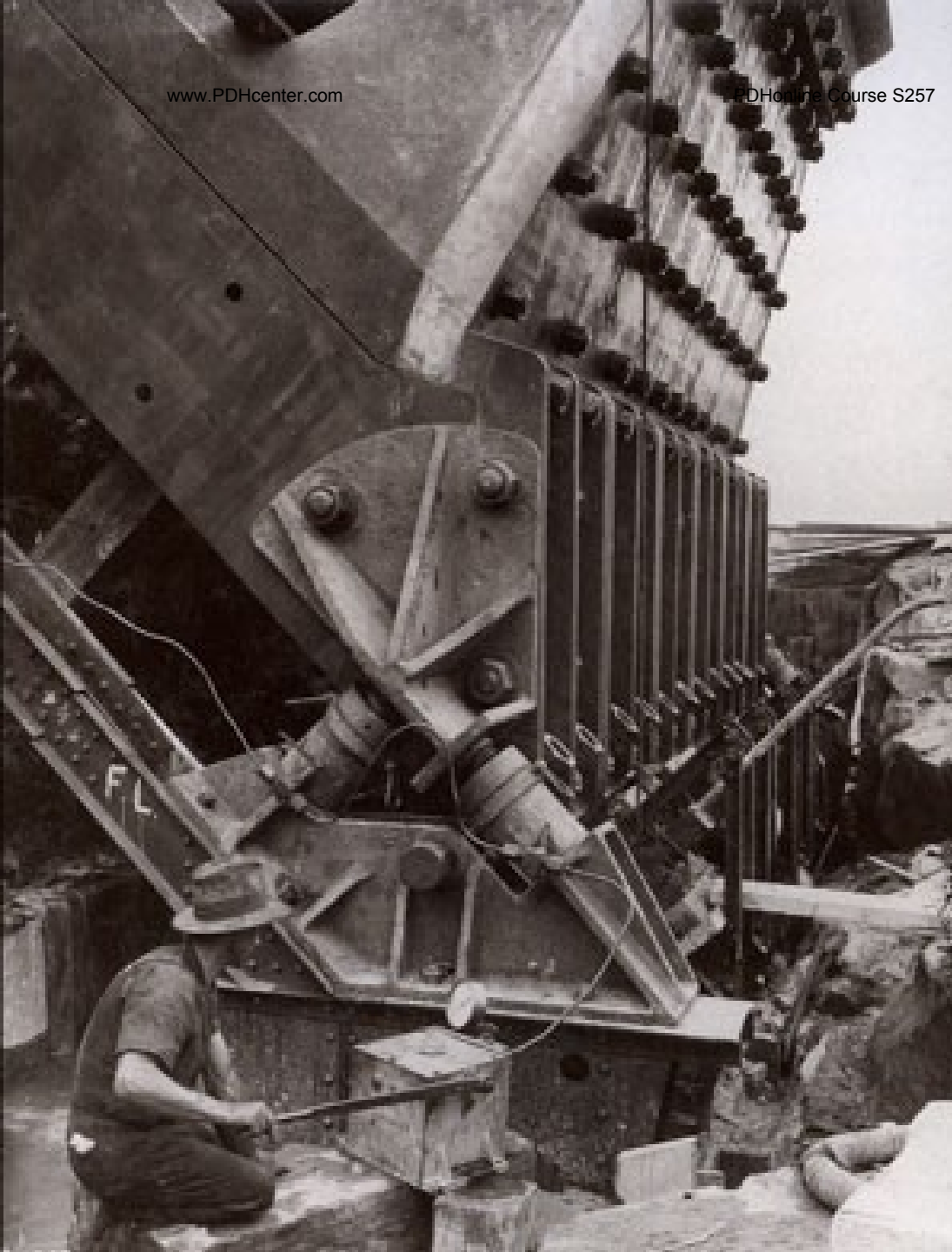

*“...The bearings themselves, which had meanwhile been installed on a temporary steel framing above the concrete foundations, were then adjusted bodily into exact position by hydraulic jacks, and there secured. So well was the work performed, that when the two halves of the arch ultimately met the error of alignment was so small as to be negligible...”*

*Wonders of World Engineering, 1938*



PDHonline Course S251



www.PDHonline.org

*“...On the foundations thus formed the hinge-bearings were installed. Except in principle, these structures were as different from the ordinary conception of a hinge as can well be imagined. Manufactured throughout by the Darlington Forge Co., Ltd., each weighed 300-tons, and had a bearing surface of 501 square- feet. Their main components were machined true to 1/1000<sup>th</sup> inch and the bolts were made with a limiting error of 1/10,000<sup>th</sup> inch...”*

*Wonders of World Engineering, 1938*

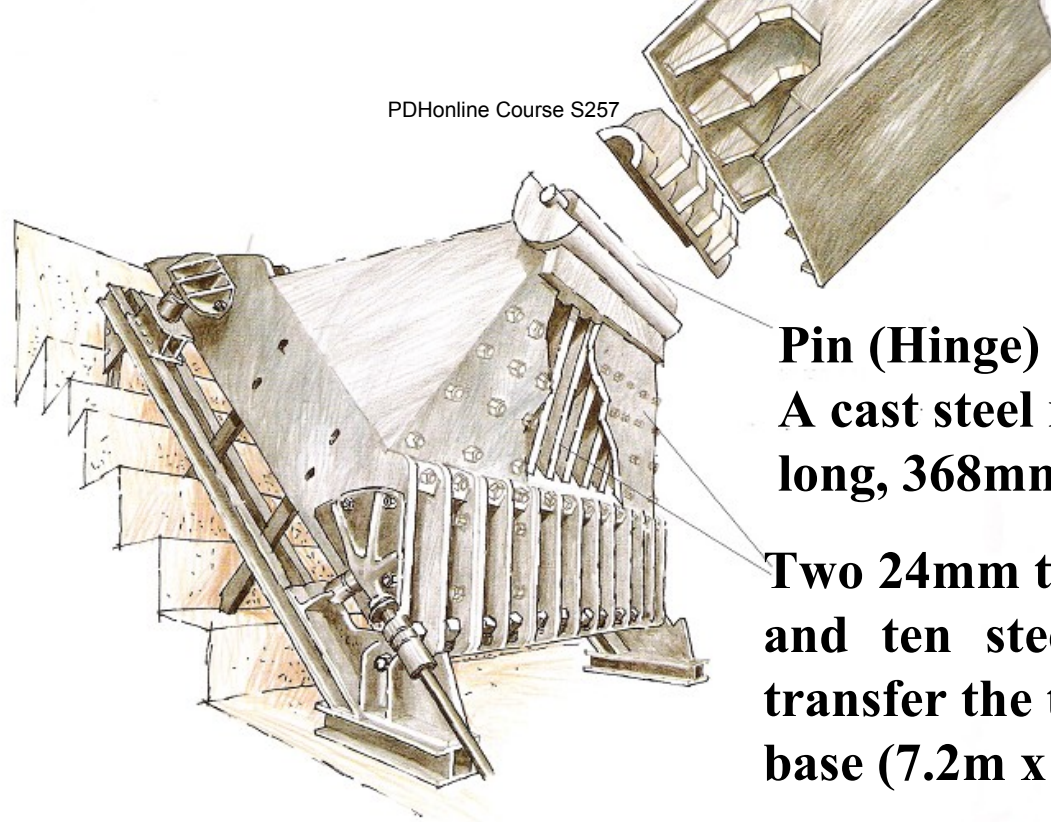
**Pin (Hinge)**

**A cast steel rod 4.2-meters long, 368mm in diameter**

**Two 24mm thick steel “webs” and ten steel “diaphragms” transfer the thrust to the steel base (7.2m x 6.3m)**

***“The lower chord of the arch transmits its thrust to the bearing pin. The pin then transmits the thrust to the lower saddle which is attached to two forged steel webs (9.5-inches thick). The two webs are held together with ten cast steel diaphragms. These web diaphragms transfer thrust to the six steel castings (bolted together to form the base) resting atop the concrete Skewback. In total, the hinge-bearing weighs 296-tons.”***



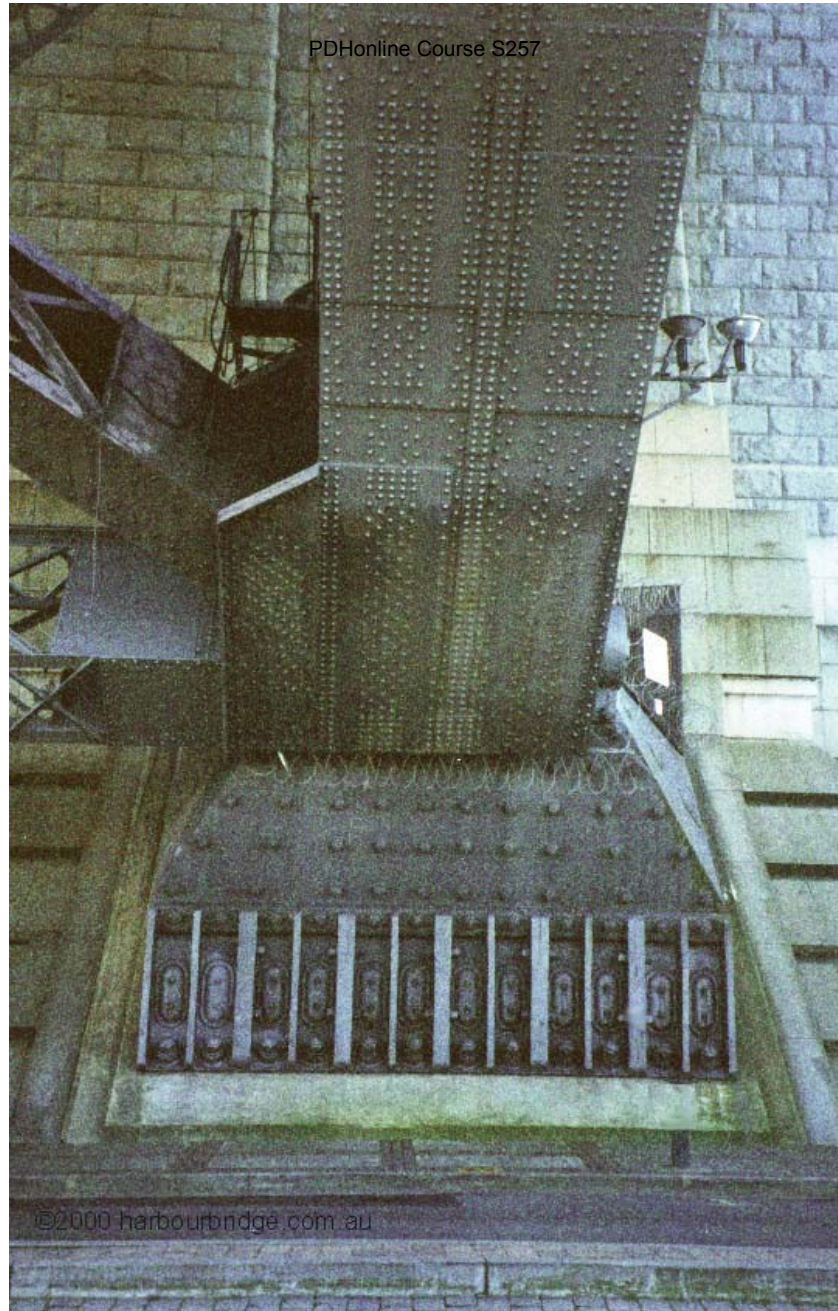

©2000 harbourbridge.com.au



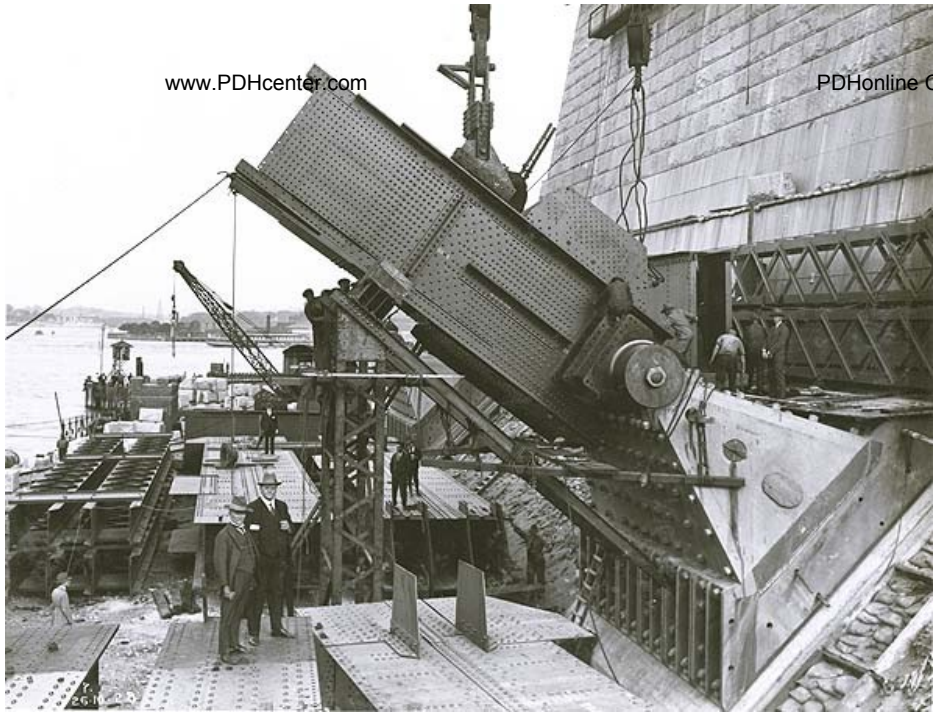

*“...From these bearings were to start, sloping upwards and outwards over the water at an initial angle of 30-degrees, the two widely separated halves of the giant arch. These halves were destined to meet in mid-air at a point some 900-feet away and 400 feet above the water. The maximum permissible horizontal deviation when they should meet was not much more than four inches, but no appreciable deviation occurred...”*

*Wonders of World Engineering, 1938*

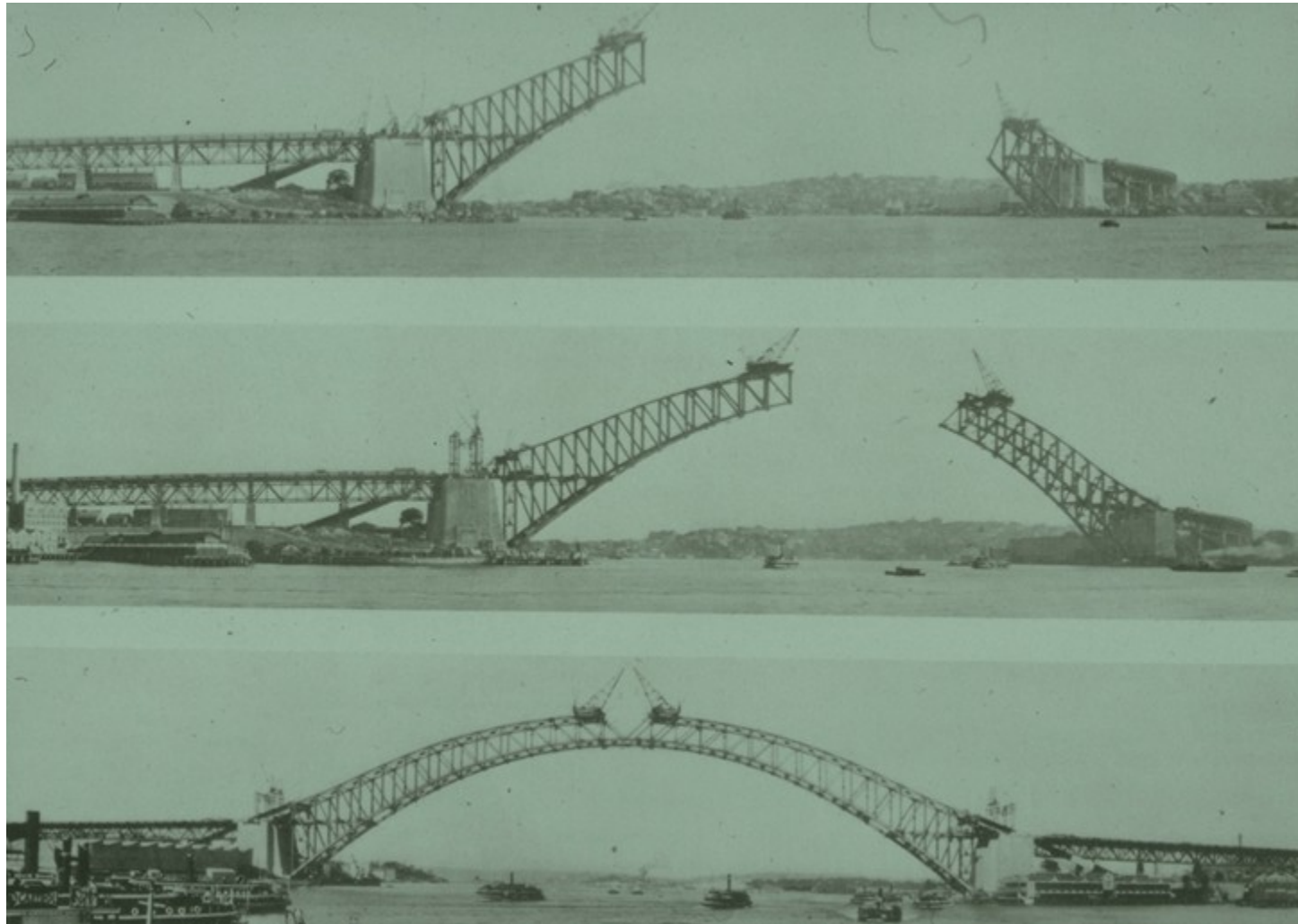

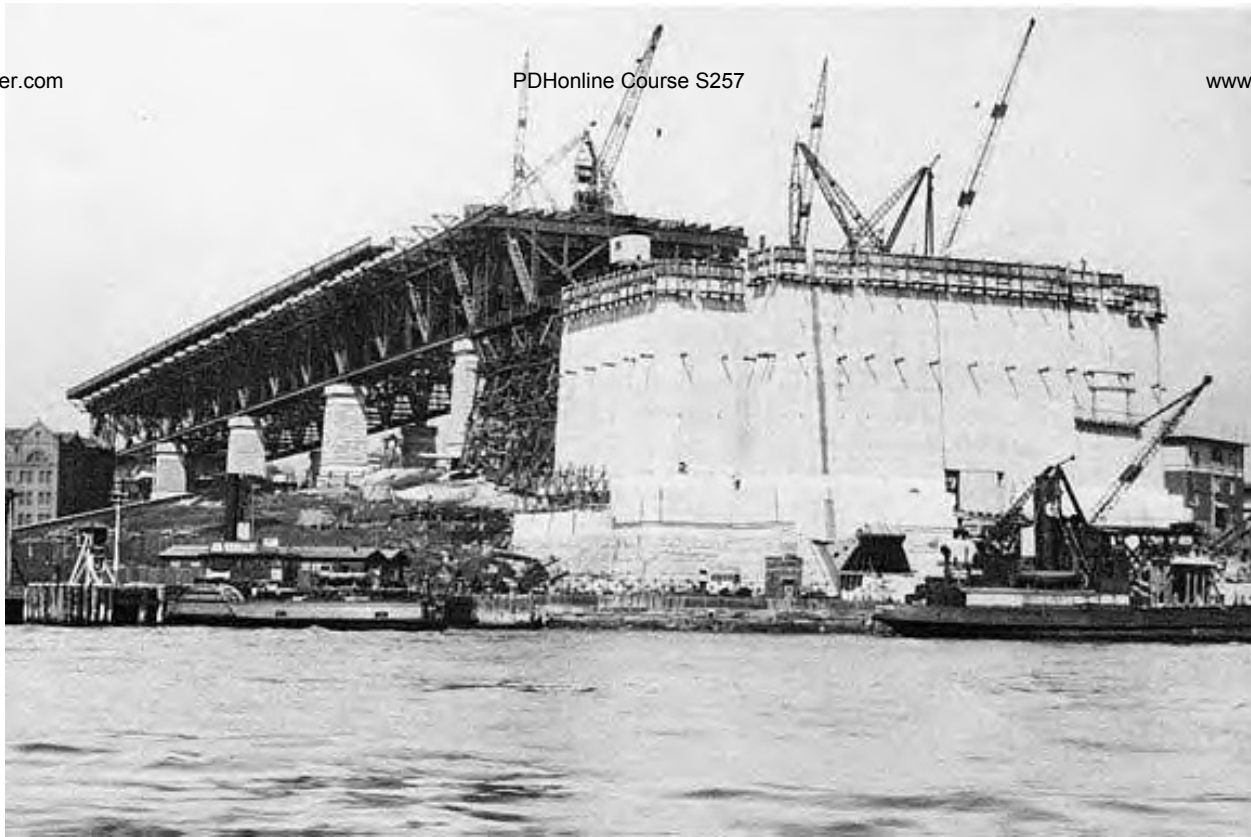

*“...The design of the bridge provided for a granite-faced concrete pylon at either end, located immediately in rear of the giant would reach a height of 285-feet, but, while the great arch was in progress, their erection was stopped at 155-feet from the ground to afford clearance for the anchorage cables and to permit the erection of the giant creeper cranes...”*

*Wonders of World Engineering, 1938*

# **ANCHORED CABLES**

*“...The width between the two shores at the point named is slightly more than 1,600-feet. As several important docks and wharves are situated higher up the harbour than the site of the proposed bridge, it was necessary for the lowest portions of this to have sufficient height above water to clear the masts of the largest vessels. For the same reason, it was stipulated that neither the finished design of the bridge nor the operations performed while it was being built should occasion any obstruction to the passage of shipping. This ruled out any reduction of the main span by the building of a mid-channel pier or piers and it also forbade the designer to support his main span from below while it was under construction...”*

*Wonders of World Engineering, 1938*



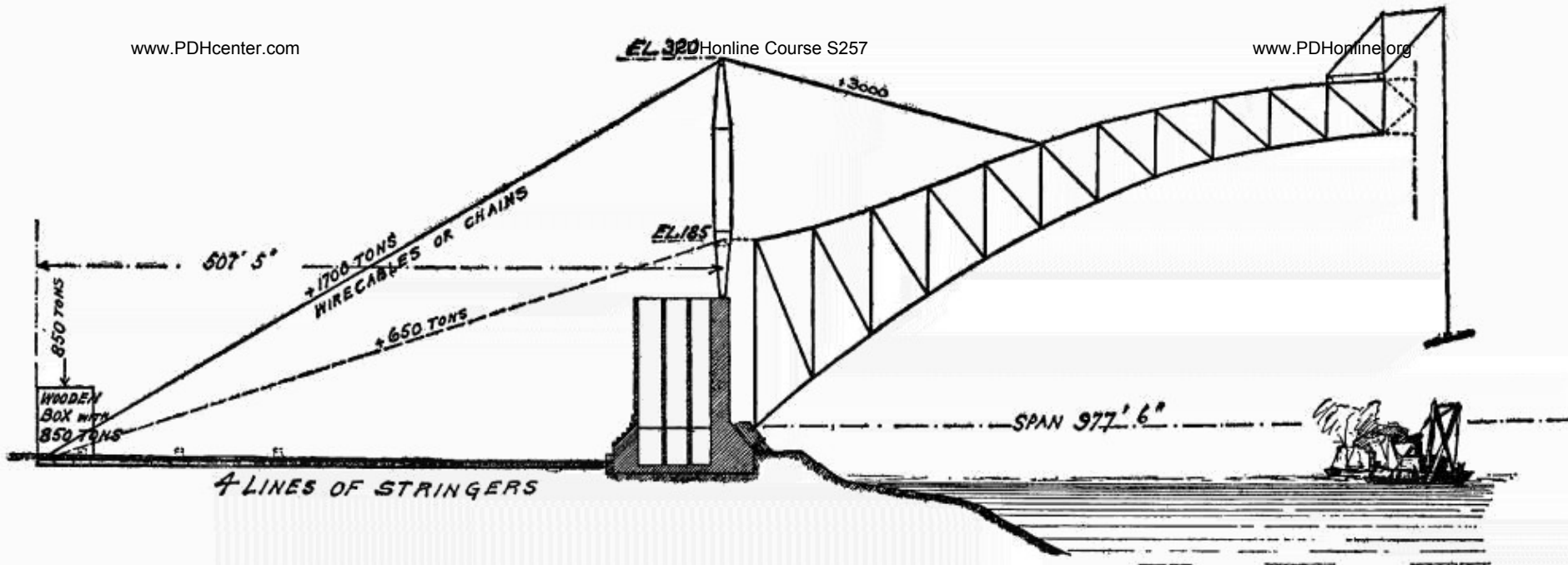

*“...Telford, long before, had proposed to build arched bridges, of wide span, without using any support from below – support being provided by wire cables, led from points on shore over a tall pylon at either end of the span. This plan was afterwards used with success by Brunel, and it may perhaps have provided a hint for the method adopted at Sydney. This was to take the strain caused by the immense overhanging weight of the half-arches, as they were built out, by wire cables anchored in the ground...”*

*Wonders of World Engineering, 1938*

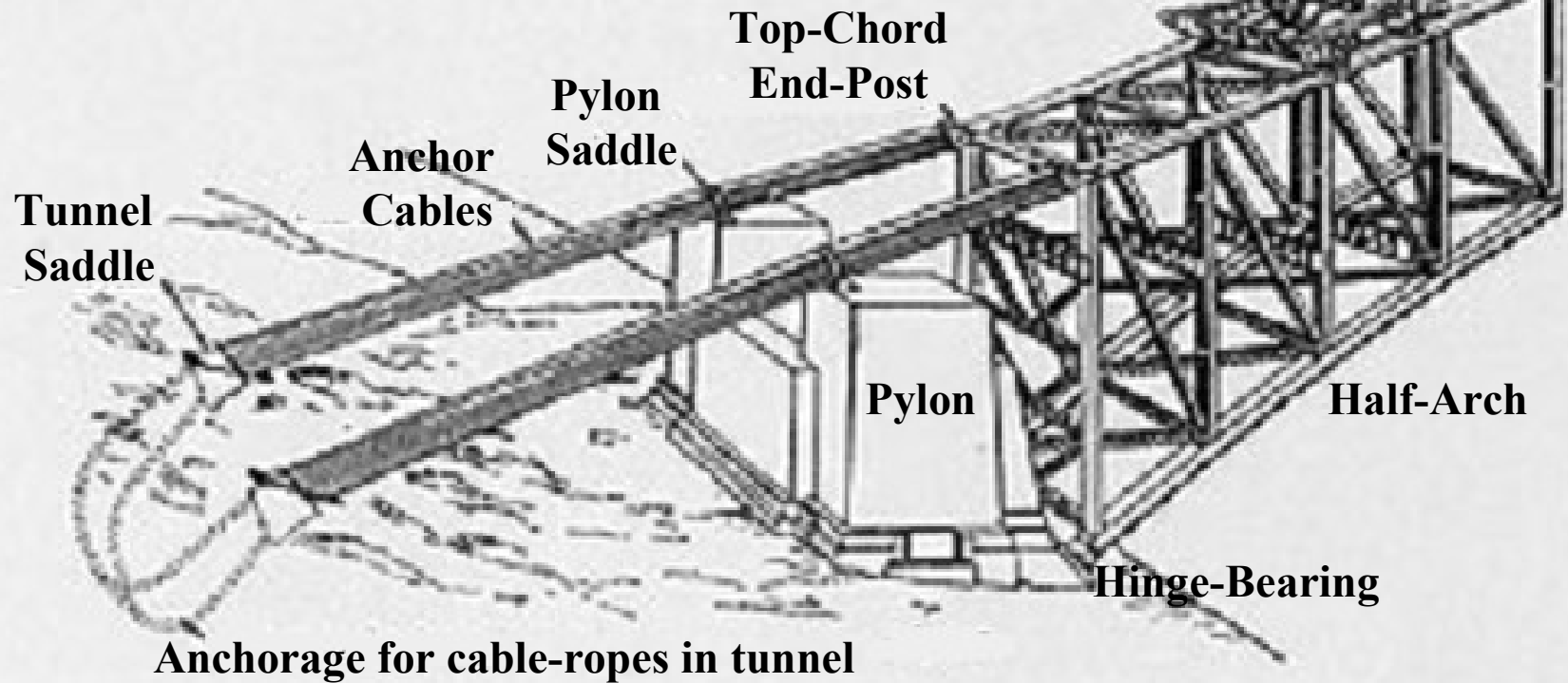

*“...The point at which the cables were attached to the half-arches was that at which the outermost of the vertical struts between the two chords met the upper chord. This point gave the maximum leverage around the hinge-bearing that could be obtained without building up a special structure for the purpose above the end of the arch...”*

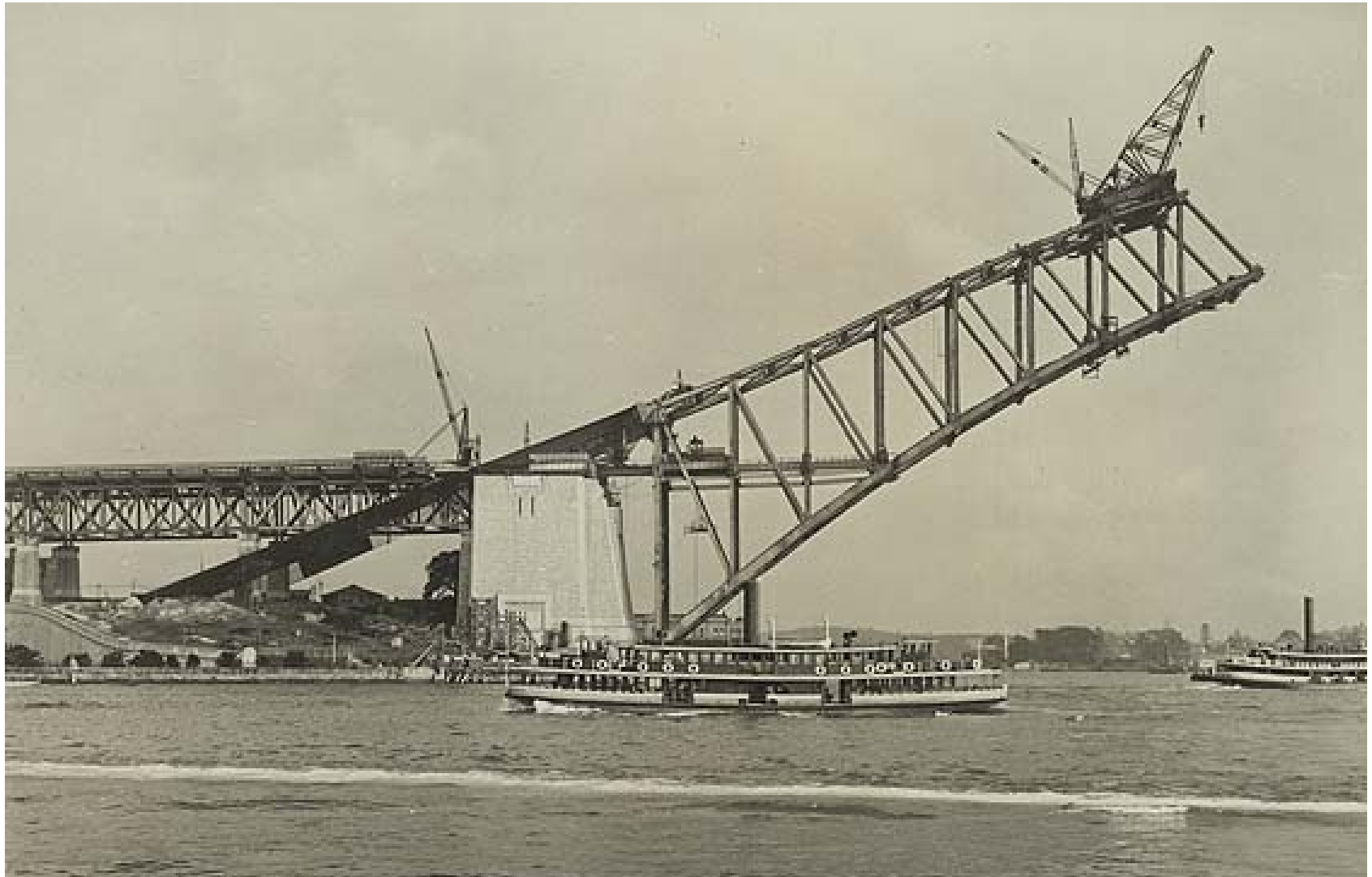

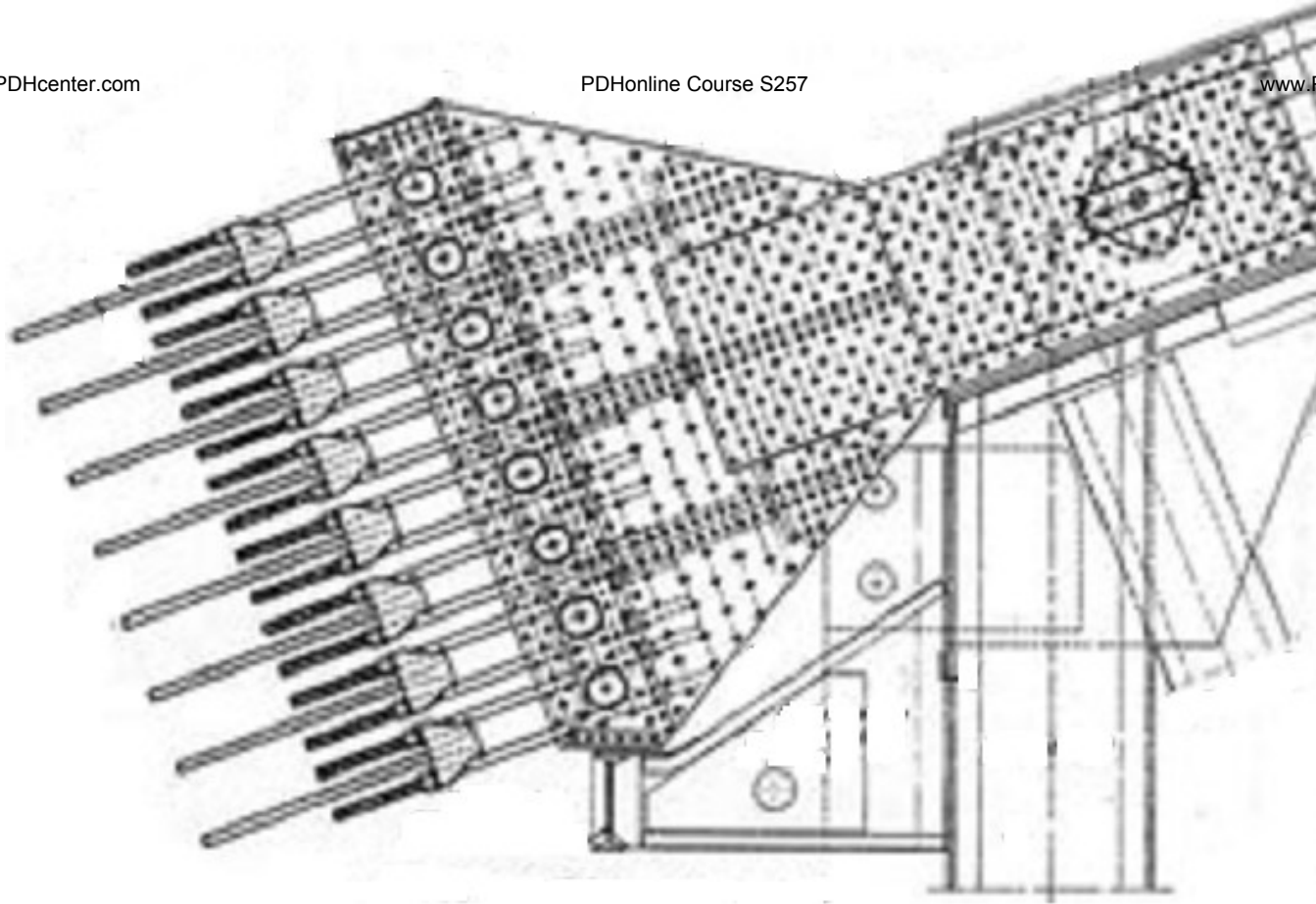

*“...The sides of the container formed the end bearings of a steel hinge-pin 12-feet long and 27-inches in diameter. The central bearing of the hinge was in the end-post of the arch. Thus the container was free to rotate slightly about a pivot and to maintain an equal distribution of the load on all the cables...”*

*Wonders of World Engineering, 1938*







*“...In all, 128 wire cables were used, each 1,200-feet long, of 2.75-inch diameter and each able to sustain a strain of 360-tons. The maximum strain imposed on them, however, was about 125-tons. Each cable ran from the top of one end-post of the arch, over the pylon, into and through the tunnel, and so to the top of the other end-post. Special steel saddles, to prevent any chafing of the wires, were installed at the pylons and the tunnel entrances...”*

*Wonders of World  
Engineering, 1938*

*“...in practice were called upon to sustain a load of 115-tons...”*

**Lawrence Ennis – Director of Construction, SHB**

**RE: the actual tensile strain on the individual wire cables during erection of the half-arches (about 1/3 that of the actual tested tensile strength of 360-tons)**

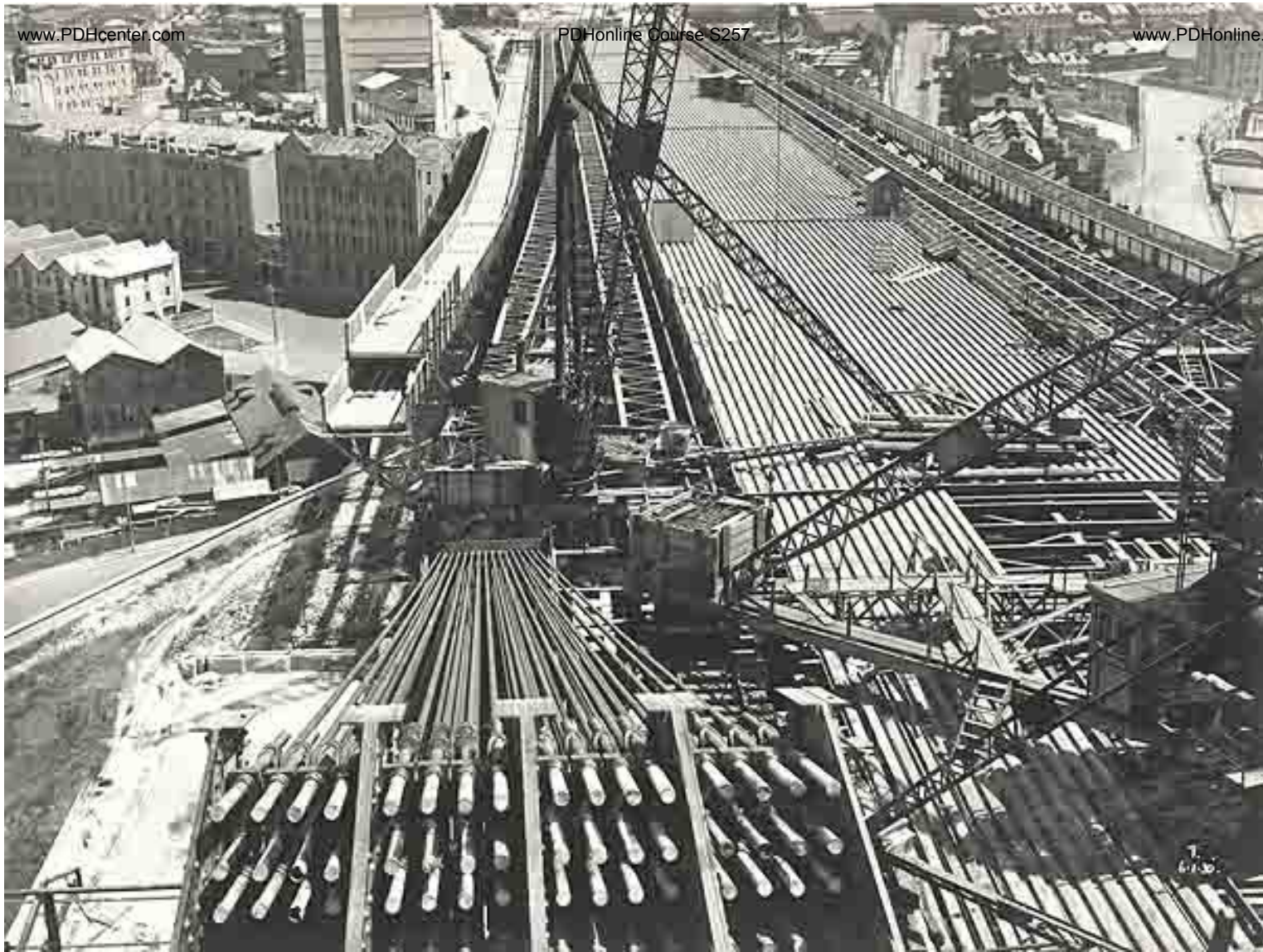

**Looking down at wire cable “Container”  
(from atop upper chord)**







## Pylon Saddle



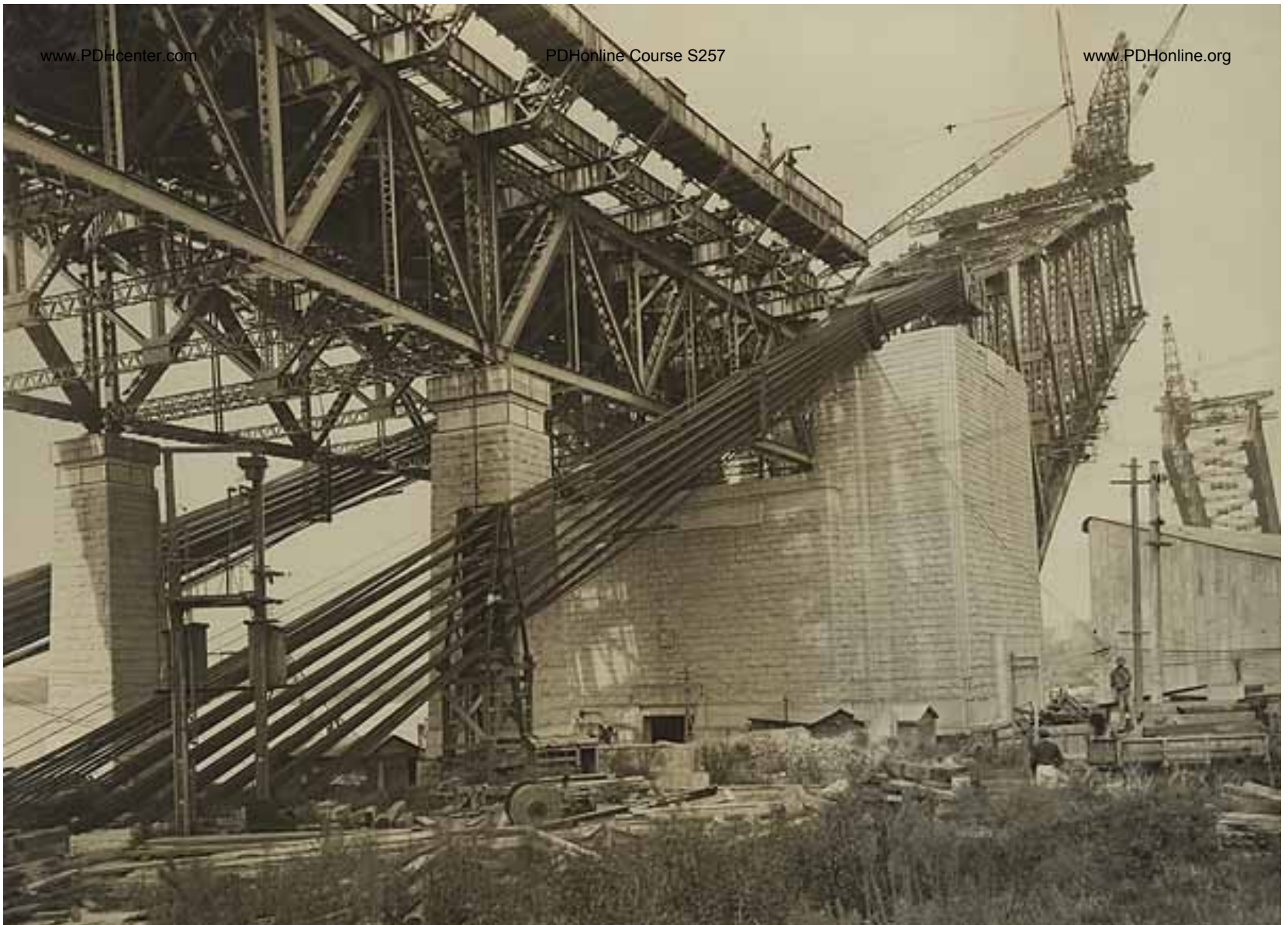

**Alignment/support tower  
(before entering tunnel)**



*“...A long way in rear of the pylons were dug the anchorages for the supporting cables. It takes much anchoring, even in sandstone rock, to hold a pull of 30K-tons or so, and each anchorage took the form of a U-shaped tunnel, the sides of the U being about 100-feet apart, and driven into the rock at an angle of 45-degrees from the vertical. The inner curve of this tunnel was lined with sheets of steel, against which, and the sandstone backing it, the cables exerted their enormous pull...”*

*Wonders of World  
Engineering, 1938*

## Tunnel Saddle



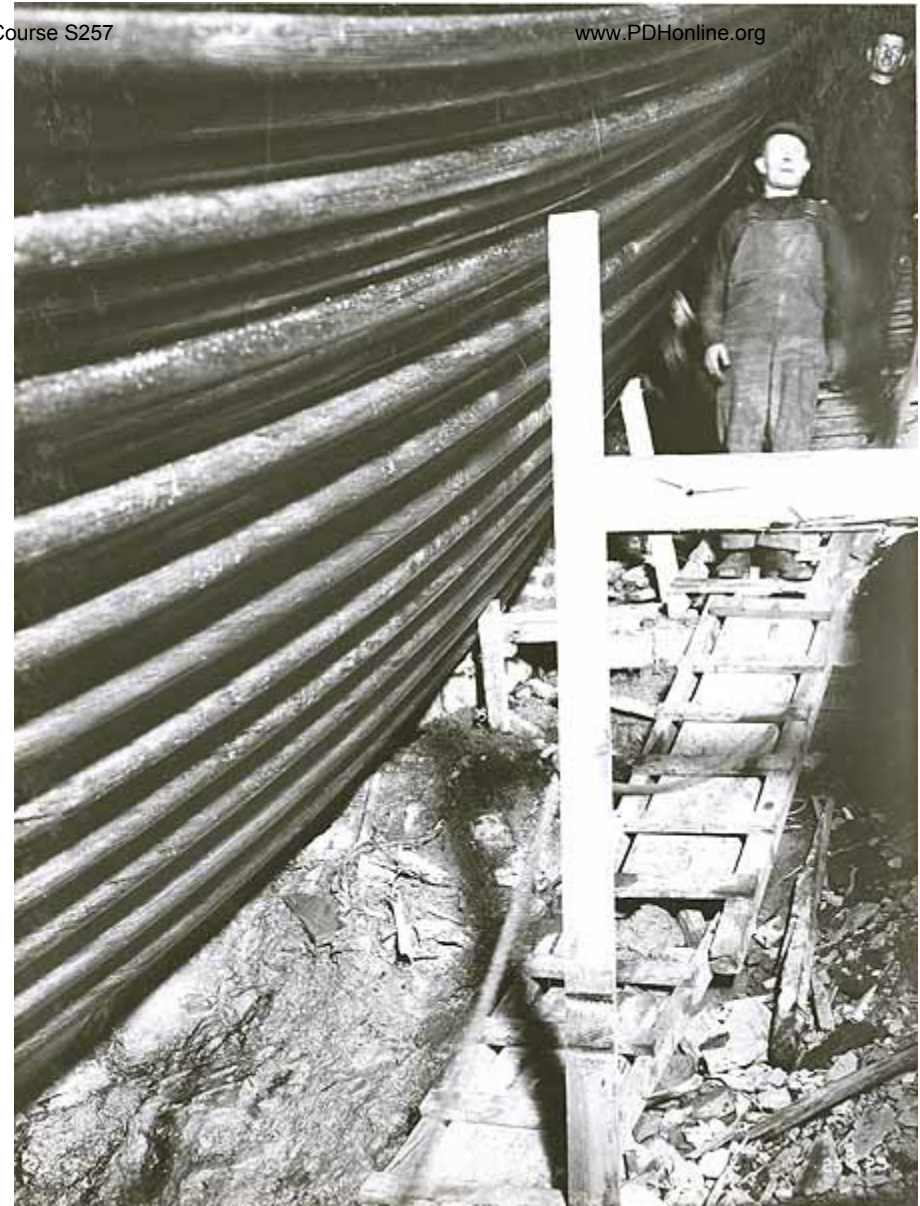
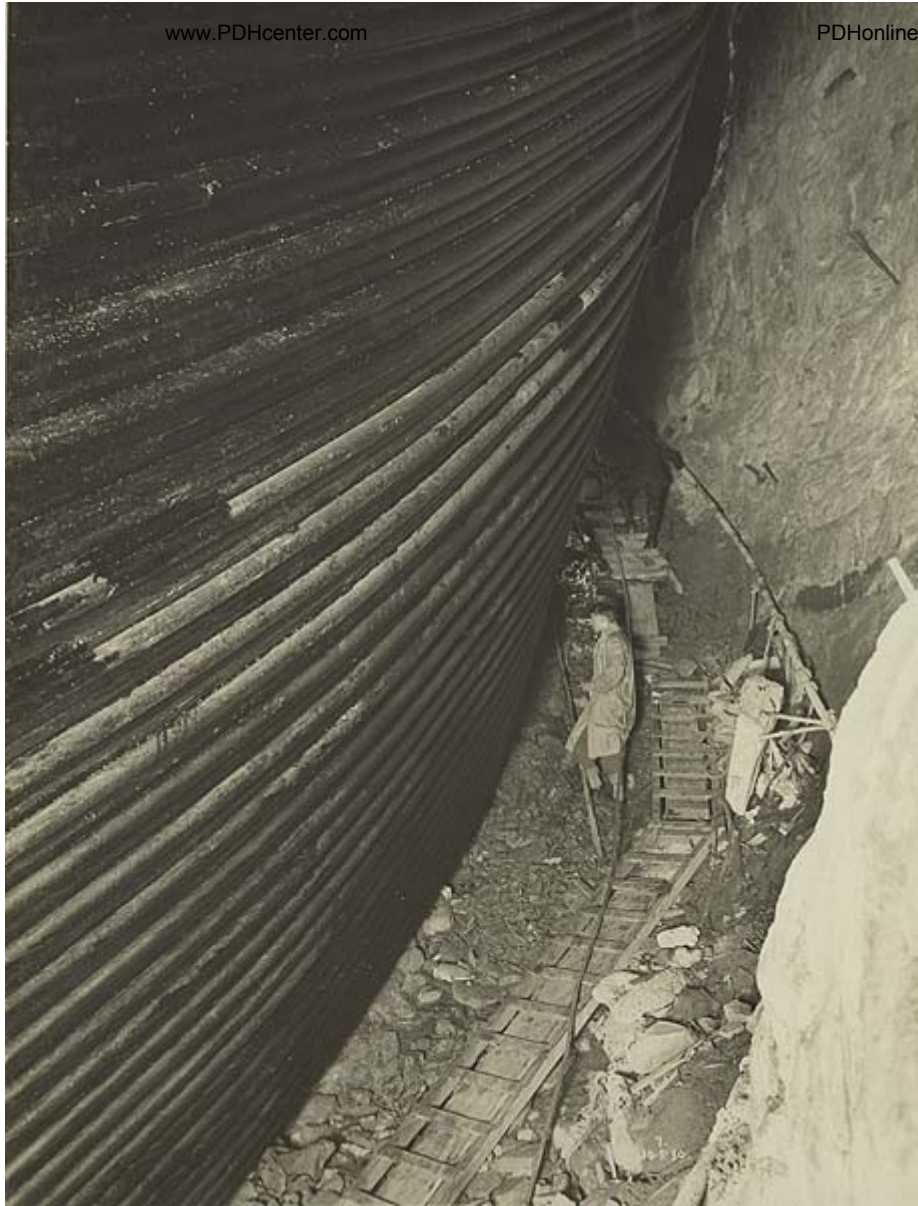

**Wire cables passing around inner tunnel wall** 192

*“...It was absolutely necessary to ensure, first, that every cable was made fast to the arch without any possibility of the attachment giving way, and, secondly, that each wire was taking its fair share, and no more or less, of the total strain. An unequal distribution of the load would mean that, as the strain on the cables gradually increased with the outward growth of the half-arches, the cable most overloaded would ultimately snap. This would at once increase the load on some other cable, already dangerously near breaking point. That, too, would give way and transmit its load to break another – and the whole giant fabric, crowded with workmen, would come crashing down hundreds of feet into the water below...”*  
*Wonders of World Engineering, 1938*







*“...Exact adjustment of the cables was effected by the nuts and bolts. After each cable had been given a provisional loading of about 10-tons, the final tensioning was effected by a hydraulic jack. A pressure gauge on this indicated when the desired tension had been reached. The nuts were then set up and the jack removed...Extra cables were added as the half-arches progressed outwards, care being taken to adjust the tension in each new cable so that all cables were equally stressed...”*

*Wonders of World Engineering, 1938*



**Checking cable tension with pressure gauge** 196



## **Adjusting nuts and bolts (at Cable Container)**

**There were two nuts at each cable end to maintain proper tension and for adjustment. After their service on SHB, some of the cables were later used on the *Walter Taylor* suspension bridge over the Brisbane River in Queensland. Other cables were used to support the deck of an arch bridge over the Save River in Zimbabwe (designed by Ralph Freeman)**

## **Pylon Saddle**

**Additional wire cables to be added as the half-arch extends outward.**

**To allow for length adjustment (to raise and/or lower each half-arch – critical when the half-arches met and needed to be lowered for joining), each cable was fixed into a steel socket whereby a bolt (with adjusting nuts) could be secured to the Link-Plate/Container.**



*“...To safeguard these vital points, the end of each cable was spread out and secured, by a plug of fused white metal, into a metal socket, this plan providing an attachment equal in strength to the cable itself. These sockets were secured, by equally strong nuts and bolts, in a gigantic steel container, being arranged in eight rows of sixteen...”*  
*Wonders of World Engineering, 1938*





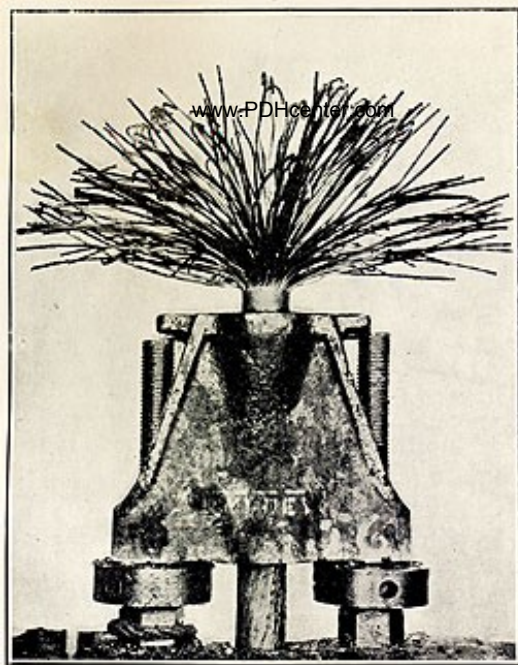

No. 1

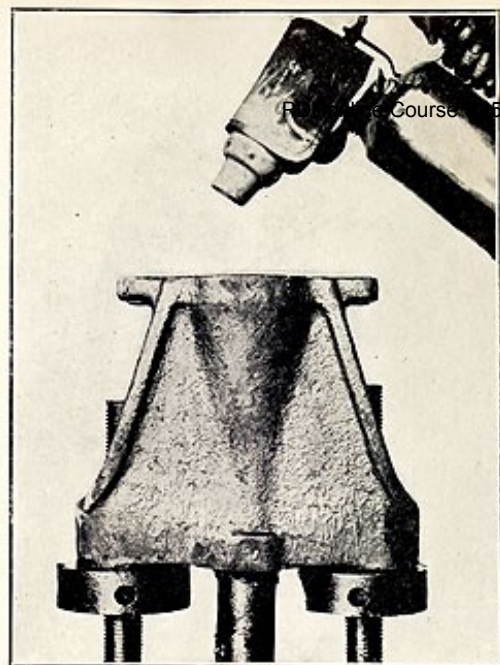

No. 2

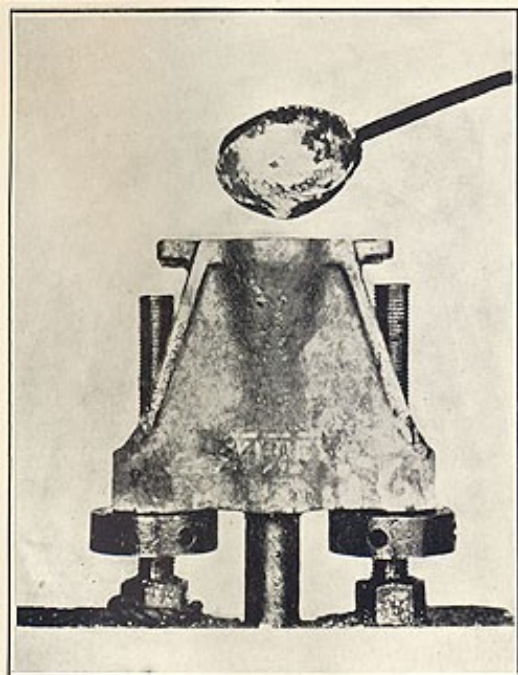

No. 3

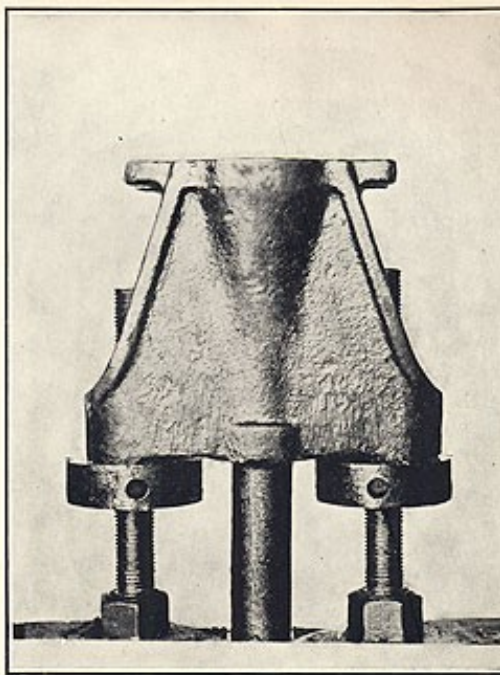

No. 4

**Photograph No. 1: Cable end fixed in steel socket - 217 wires are splayed out, cleaned and folded back onto themselves**

**Photograph No. 2: Cable pulled back until wires are tightly fixed in the socket**

**Photograph No. 3: The socket is filled flush to the top with molten white metal (low melting point alloy, typically lead and/or tin). Reaction with the steel wires creates intermediate alloy (akin to soldering)**

**Photograph No. 4: Finished steel socket**

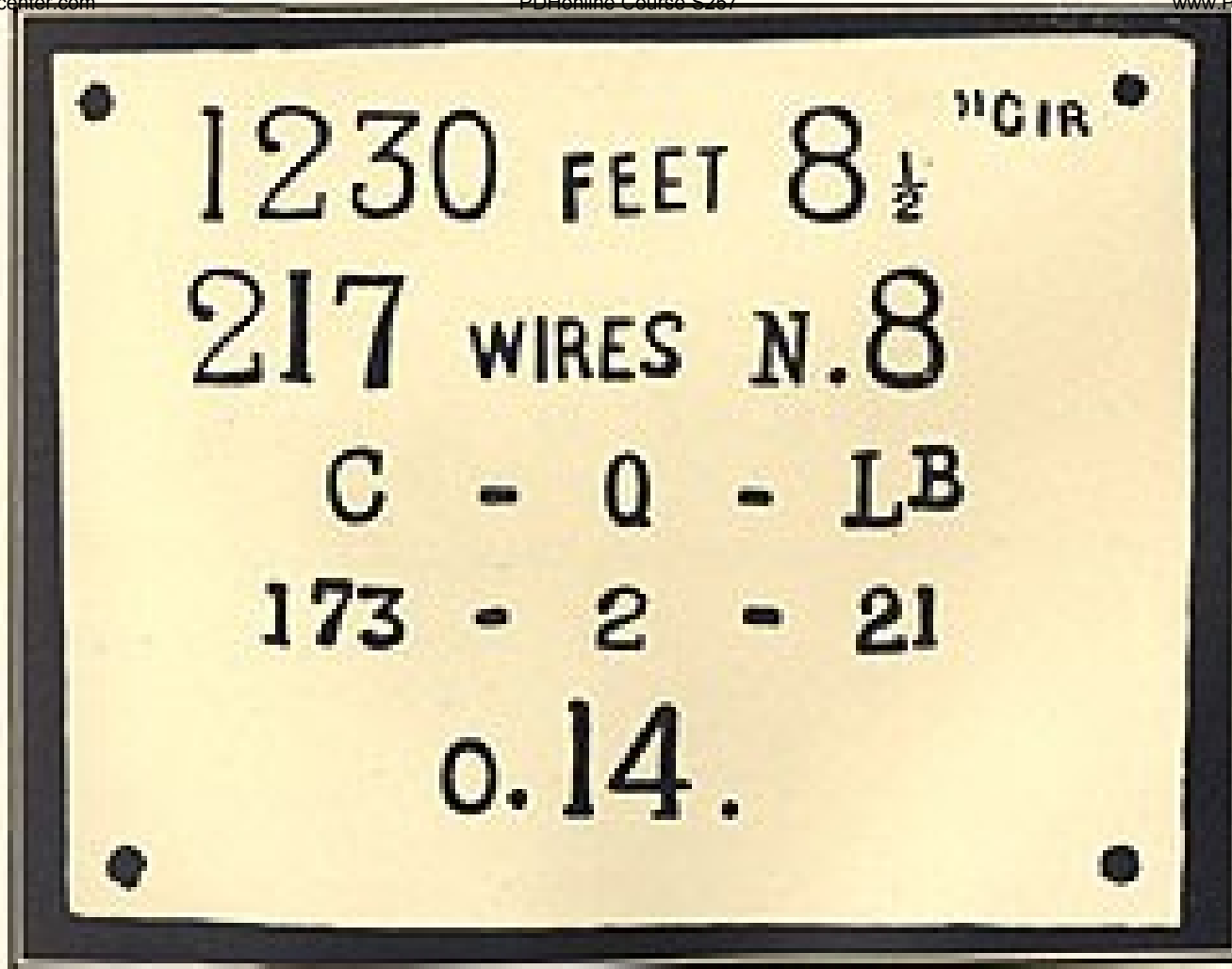

**Identity Disc  
(attached to each individual cable)**

# **The Brute Force Method**





***Hell Gate Arch (under construction)***  
**ca. 1915**





**Gustav Lindenthal chose to use a massive temporary steel frame (each side) to support the half-arches of the *Hell Gate Bridge* during construction. As was the case in Sydney, the Hell Gate was/is an important waterway whose navigation could not be disturbed.**



# **CREEPER CRANES**

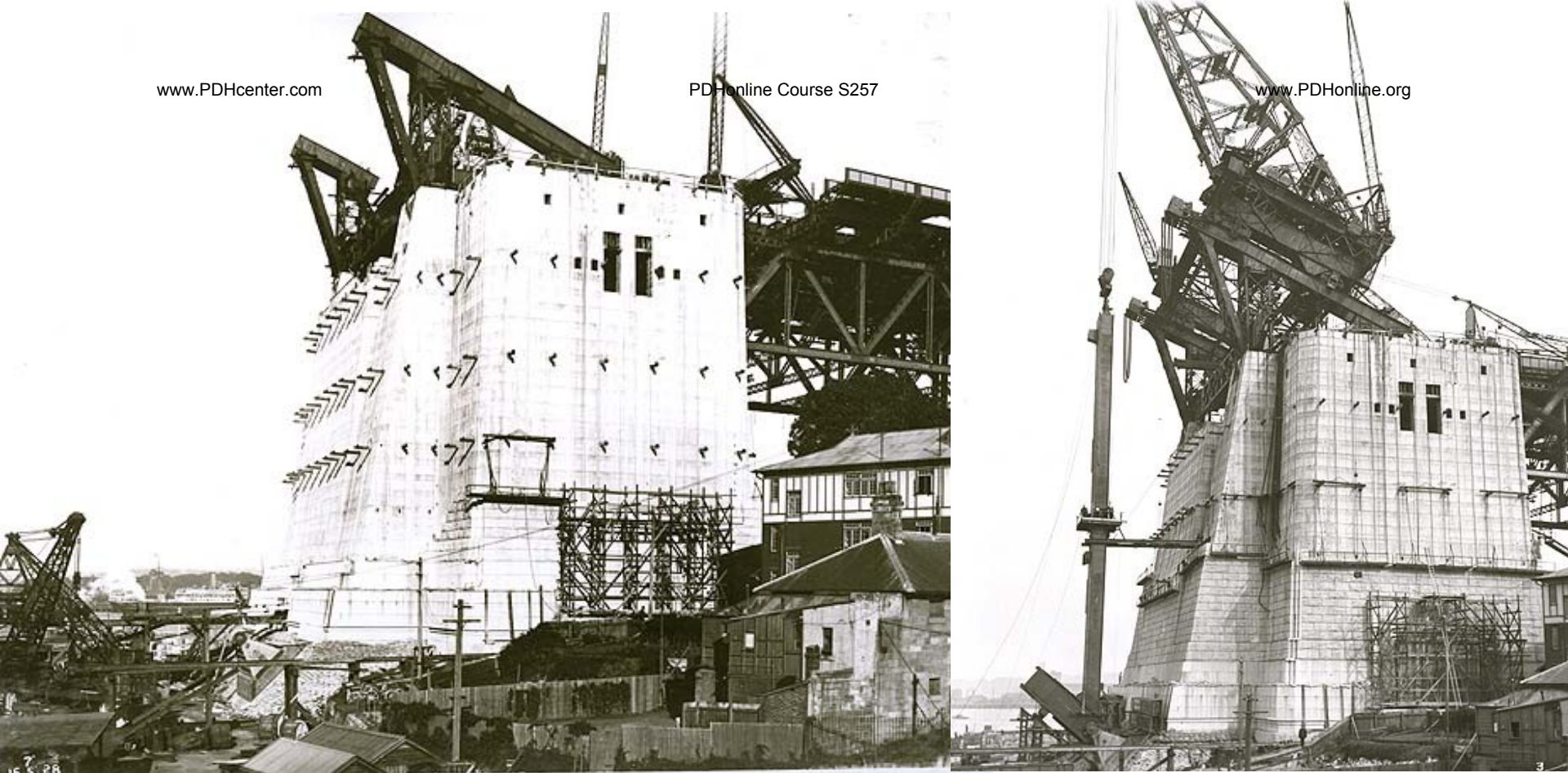

*“When the abutments reached the bridge-deck level, the 25-ton cranes were used to build a steel ramp atop the abutments upon which the ‘creeper cranes’ would be assembled. The two creeper cranes would then move off the ramp from each abutment assembling the steel arch in front of them as they progressed.”*

**RE: excerpt from: *Building the Sydney Harbour Bridge***





*“As a rigger, you’re here and there. You’ve got to do almost everything...the noise was terrible at times. Building the creeper crane was one of the trickiest jobs in my life. You had to hang on by your eyelashes. You couldn’t stand. You had to hang on.”*

**Harry Tomrop – Steel Rigger, SHB**

**RE: as one of twelve steel erectors on SHB, he was well aware of the dangers involved in his line of work. Danger was familiar to him as a pilot during WWI and a former New York Skyscraper-man.**



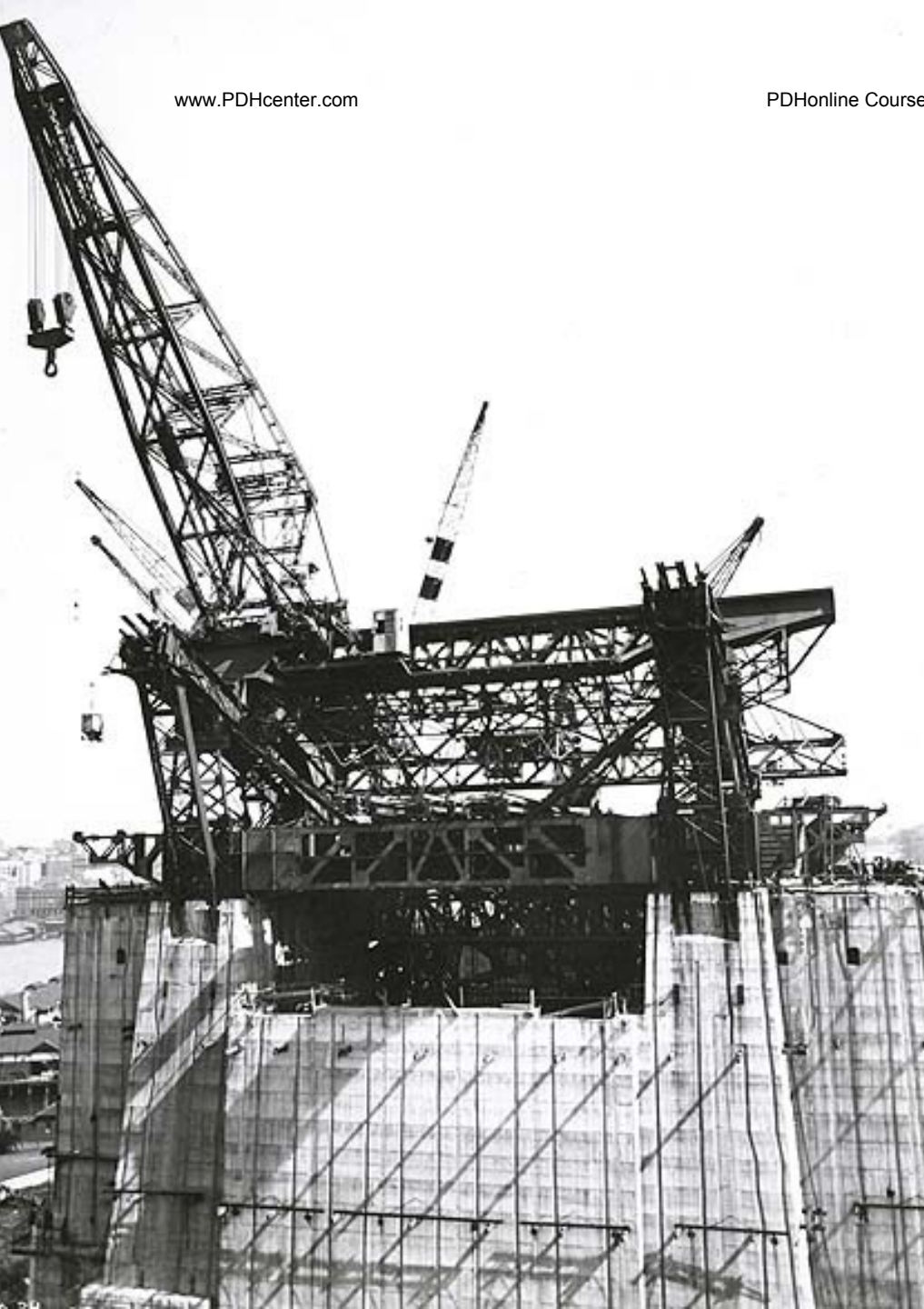

*“...Up this ramp, as soon as the first panel was completed, there slowly hauled themselves two enormous creeper cranes, weighing 602-tons each and capable of handling loads of 122-tons. As soon as these were safely in position straddling the upper chords, the ramps were demolished and the work of attaching the cables began...”*

*Wonders of World Engineering,  
1938*



**Creeper crane atop first (arch) panel  
Ramp removed and wire cables in-place**

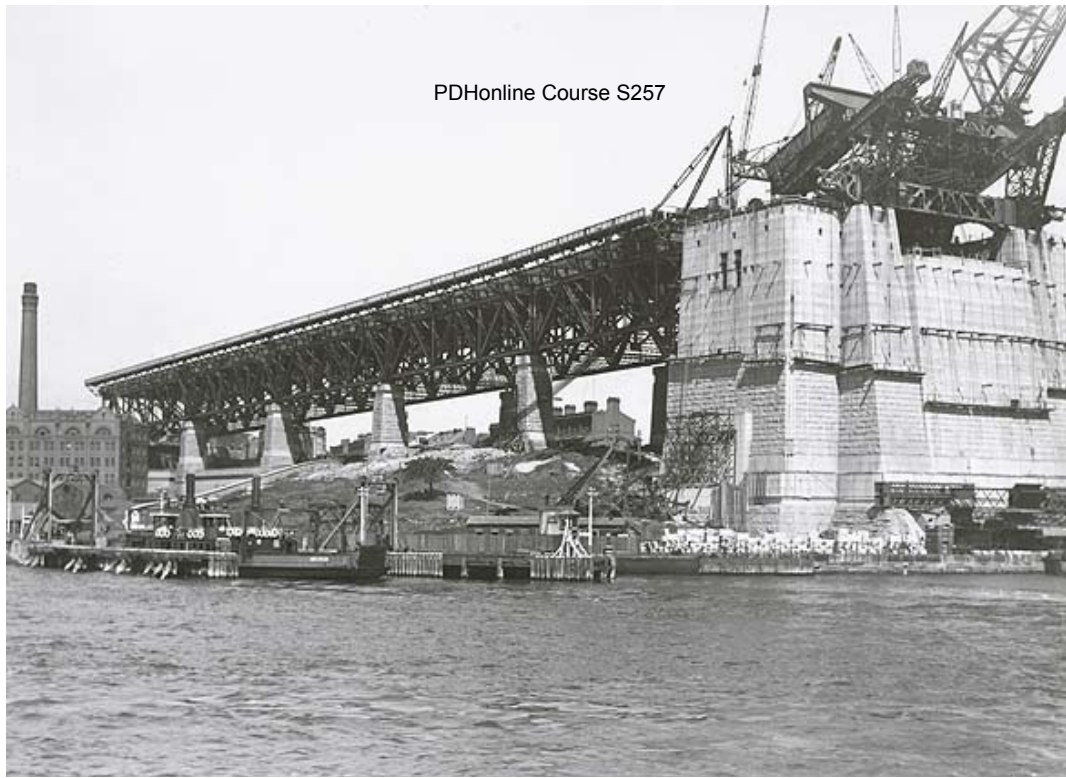

***“December 1928: From the southern end, the creeper crane begins to assemble the first panel of the arch which includes some of the heaviest sections including the bearing hinges (two each per abutment) and pins which attach it to the bottom chord and transfer the entire thrust of the arch into the abutment. By March, 1929, the first panel is complete and the creeper crane is moving off the abutment ramp onto the steel arch itself.”***

**RE: excerpt from: *Building the Sydney Harbour Bridge***





*“...The first panels being thus firmly anchored, the sides of the great arch began to extend outwards over the harbour panel by panel, the outermost panel always topped by the creeper cranes...”*

*Wonders of World Engineering, 1938*





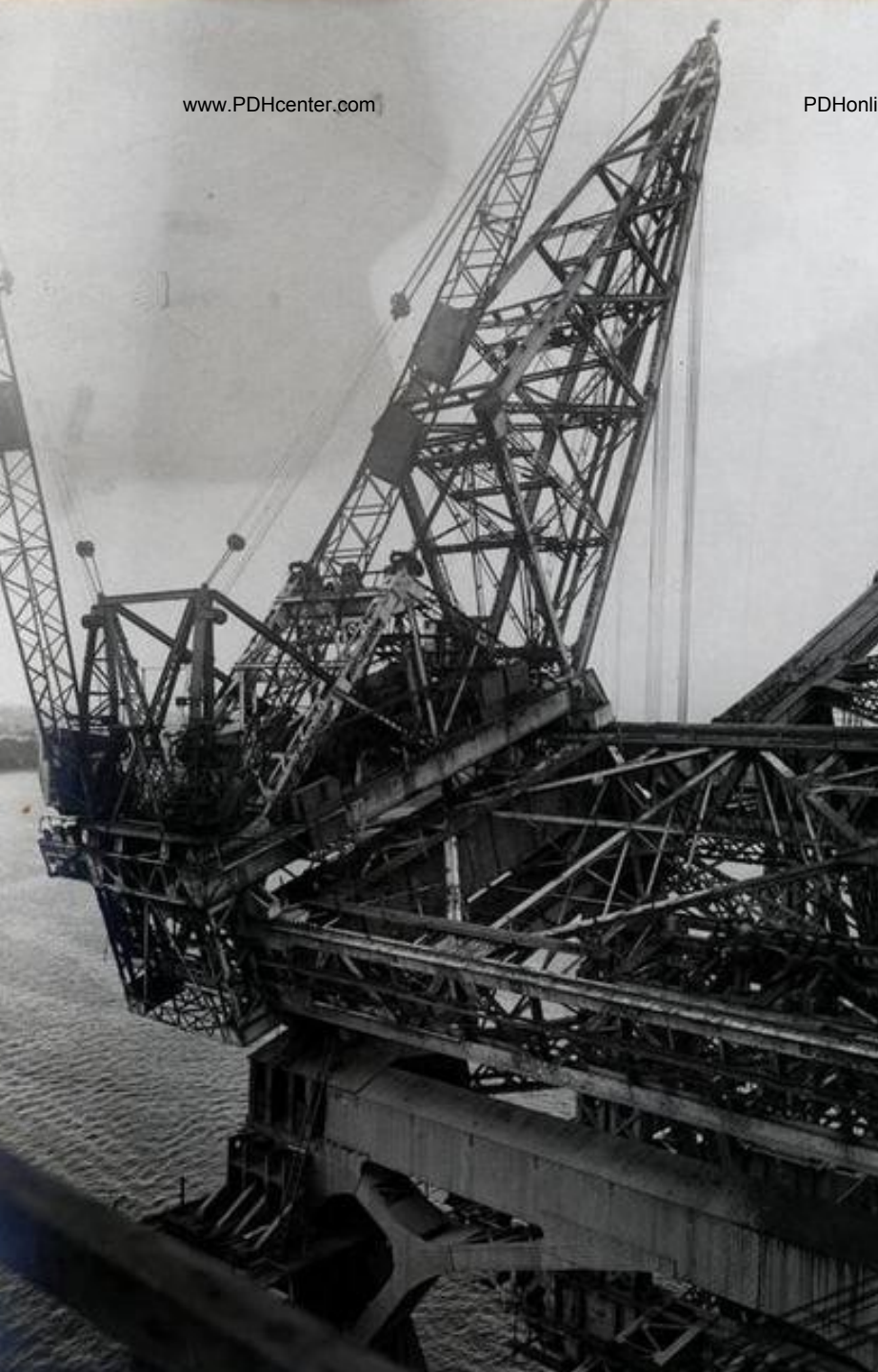

*“...These, built and tested in England, were really a battery of cranes on one platform; for, in addition in addition to the main jib crane (105-feet long, and also carrying a supplementary 20-ton hoist), they embodied two 212-ton derrick cranes and a 5-ton wall crane. With these cranes, gradually advancing on four-wheel bogies along the upper chords as the work advanced, every piece of material was picked up, lowered into place and built in. No use was made of chain or rope slings throughout the work, every piece incorporating its own special lugs for hoisting...”*

*Wonders of World  
Engineering, 1938*



*“Each of the two creeper cranes consisted of five cranes on one traveling base weighing 610 tons total:*

- Main Crane: 124 ton lifting capacity. It could move from side-to-side allowing it to work on each of the two steel trusses either side of the steel arch*
- Two small cranes at the back of the platform used to lift smaller loads*
- Two “jigger” cranes at front – used mainly to control the position & angle of the load being lifted”*

**RE: excerpt from: *Building the Sydney Harbour Bridge***

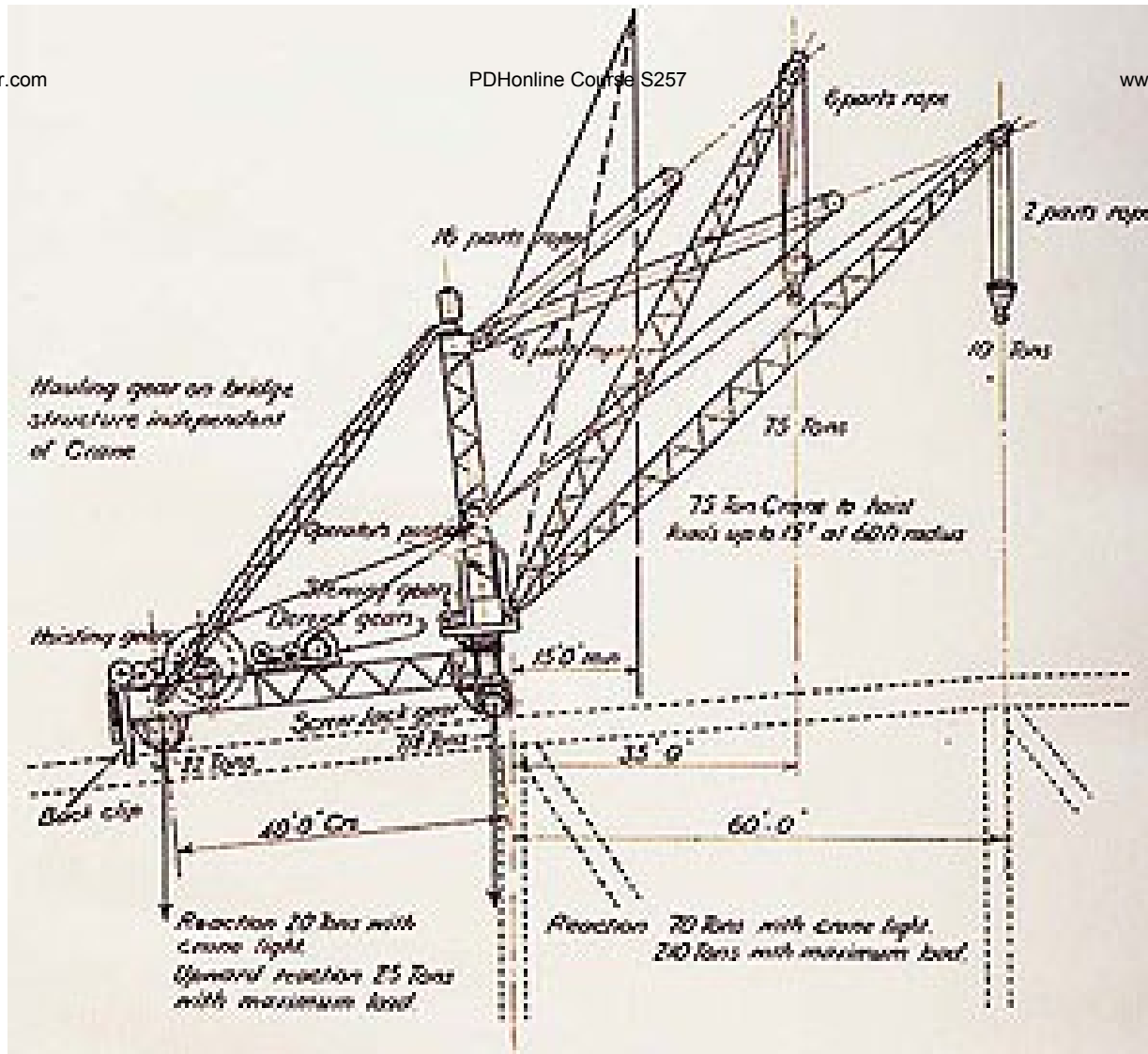

***Diagram of a Crawler Crane from  
Sydney Harbour Bridge: Report on Tenders  
(hauling gear on bridge structure independent of (main) crane)***





*“...the heaviest lift made during the erection of the half arches was 110-tons, occurring in the bottom chord of the sixth panel...the lifting capacity of the creeper crane was 122-tons with its main hoist”*

**Lawrence Ennis – Director of Construction, SHB**







*“...The great arch once finished, the creeper cranes, which had met at the summit, reversed their progress, moving slowly down the slopes of the upper chord as they hoisted into place the long vertical hangers, weighing anything up to 35-tons each, by which the horizontal trackway was suspended from the arch...”*

*Wonders of World Engineering, 1938*



# APPROACHES



On the southern approach the five spans are each 193 feet 7 inches to centres of bearings, with piers 195 feet 7 inches centres, and the approach is straight. The northern approach leaves the main span on a curve of 2,152 feet radius running into a curve of 1,300 feet radius at the northern end of the approach, so that the inner approach trusses are 168 feet span, whilst outer trusses are 180 feet 6 inches span to centres of bearings, and the piers are 178 feet 7 inches centres measured along centre line of the bridge. All approach spans are supported by granite faced concrete piers measuring 17 feet 6 inches by 14 feet at the top and tapering uniformly outwards towards the base, the average height of the piers being 50 feet above ground level.

All approach spans are carried by two main truss girders, which are supported by independent piers. Two cast steel bearings on each pier, bedded on a dressed granite cap, support the main girders of adjacent spans. The spacing of the two main trusses of each approach span is 98 feet 6 inches centre to centre, and the trusses are 34 feet 10 inches deep, braced on a simple triangular system with verticals at each panel point. Cross-girders rest at each panel point on the top chords of the main trusses and support the remainder of the floor system on their top flanges. Lateral bracing is provided in the plane of the top chords with transverse frames in the planes of the end posts; while at each panel point the cross-girders are trussed to form sway bracing to the span. The whole of the approach spans and deck are built of carbon steel.



*“...The work of clearing the sites for the approaches had begun in July 1923, long before the contract for building the bridge was awarded, but the construction work dates from January 1925, when a start was made upon the spans of the southern approach. The site for the northern spans became available some months later. This part of the work, being carried out on land, and with the spans supported on timber framework during construction, presented little difficulty...”*

*Wonders of World Engineering, 1938*





*“...These approaches, with a span of 238-feet, presented their own problems – the northern approach had to be set out in a marked curve – but by comparison with those involved in the erection of the main arch, such difficulties as they introduced appeared almost trifling...”*  
*Wonders of World Engineering, 1938*



**Because the northern approach required a horizontal curvature of 362-meters radius, consideration for the lateral force exerted by two trains traveling at a speed of 80-mph was taken into account.**



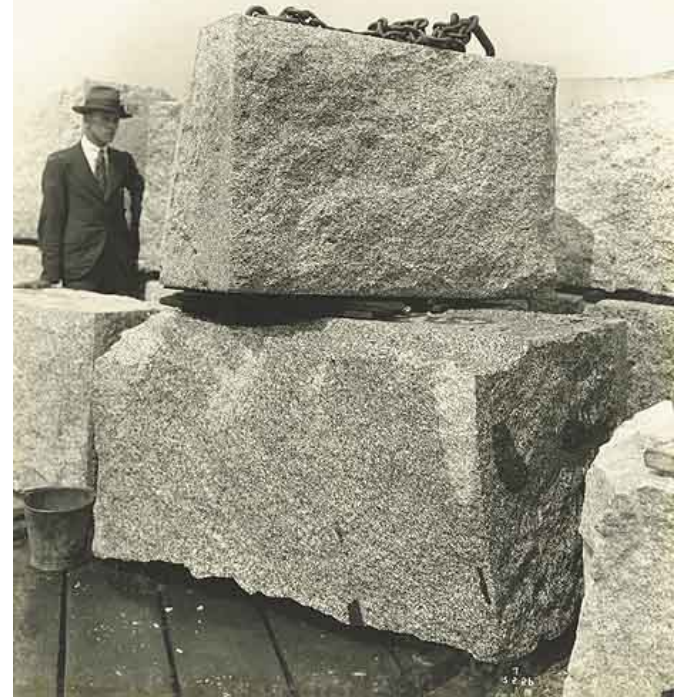

***“Typical concrete approach pier with granite facing. On October 27, 1925, the first of about 40,000 stone blocks is laid. At Moruya, each block is precisely cut, shaped and marked for exact placement at the bridge site. By September, 1926, all support piers for the approach spans are complete.”***  
**RE: excerpt from: *Building the Sydney Harbour Bridge***



*“The two steel trusses for each of the ten approach spans were erected piece-by-piece atop a timber ‘falsework’ made of Oregon – a softwood from North America. A 5-ton crane creeping forward atop the trestle was used to assemble the temporary trestles. Upon completing an approach span, the trestle was dismantled and re-used for the next approach span.”*

*RE: Excerpt from **Building the Sydney Harbour Bridge***





*“Pieces of steel for the approach trusses were lifted by 25-ton cranes creeping forward atop the newly erected trusswork. Each approach span consists of a pair of six-panel, parallel-chord steel trusses.”*

**RE: excerpt from: *Building the Sydney Harbour Bridge***



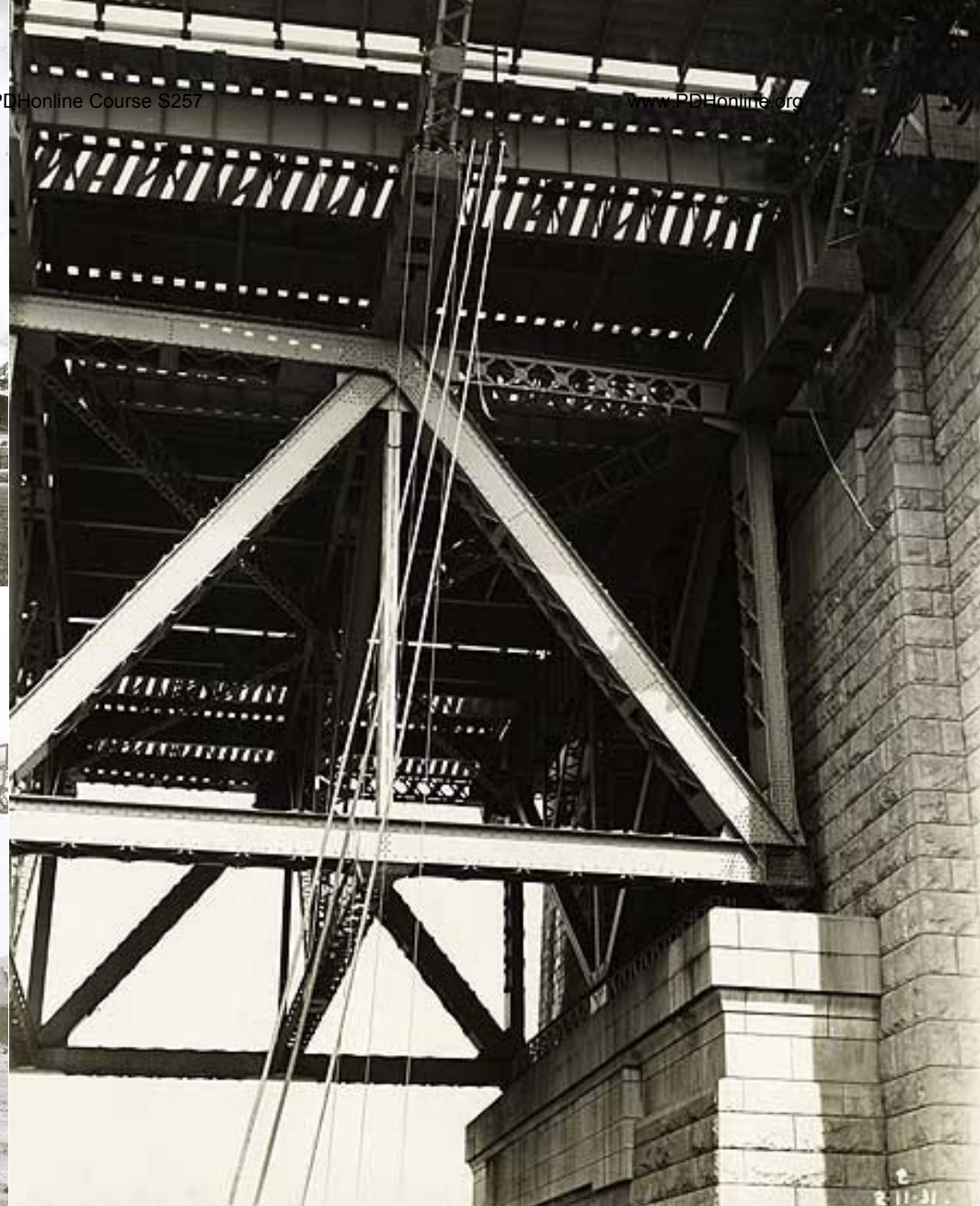

**South Approach (at abutment)**





**View of South Approach  
(from top chord of completed arch)**

# MORUYA



*“Granite is the strongest and most beautiful stone, which has withstood the ravages of time for thousands of years...”*

**JJC Bradfield – Chief Engineer, SHB**



***“All granite for the piers, abutments/pylons will be quarried from Moruya, a coastal town 300km south of Sydney. Dorman, Long & Co. built a town to house 250 quarry workers and their families in 72 pre-fabricated houses. Two-hundred skilled stonemasons were recruited from Scotland & Italy. The town included a stone crushing plant to make gravel for the concrete & wharves for three-400-ton ships built specially for transporting the stone blocks to Sydney.”***

**RE: excerpt from: *Building the Sydney Harbour Bridge***





# Granite Quarry







## Crushed Stone Plant



## Stone Finishing Shop





# Wharves



*“...Here again the plant required was shipped from England, but the transport of the stone from Moruya to Sydney was performed by, a little fleet of three steamers of 400-tons carrying capacity, built in New South Wales. On their return trip to Moruya these vessels brought cargoes of food supplies and drinking water, it being impossible to procure sufficient food and water locally for the 240 men employed at the quarry and for their dependents...”*

*Wonders of World Engineering, 1938*

# WORKSHOPS

## Fabrication.

Messrs. Dorman Long & Co., Limited, already have works at Sydney and Melbourne, and arrangements have been made, apart from the Sydney Harbour Bridge contract, for constructing more extensive shops in Sydney. These shops will be used immediately for the construction of the special shops for fabricating the material for the bridge.

The proposed new workshops will rank among the heaviest shops of the character now in existence, and will be provided with the finest equipment of heavy structural fabricating machinery that it is possible to procure. The shops will be constructed in two portions—one being 600 feet long and 149 feet wide to centres of crane rails consisting of two 73 feet bays, and the other being 600 feet long and 130 feet wide consisting of one bay only. The two-bay shop will be utilised for the preparation of the individual pieces of the bridge members in detail, the processes carried out comprising templating, shearing, planing, drilling, riveting, &c., and all the necessary machinery will be specially designed for the work. The two 73-foot bays in this shop will be equipped with four modern electrically-driven overhead cranes.

The second shop, 130 feet wide in one span, will be devoted to the assembling of the various pieces dealt with in the first shop to form the finished bridge members. After the bridge members are assembled, they will be riveted up and the ends will be machined to the finished lengths ready for erection. In this shop will be located the heavy hydraulic and pneumatic riveting machines and the specially designed end-planing and pin-boring machines. After completion, the various bridge members will be assembled in panels in the position ultimately taken up in the finished structure, and all splices and connections at the junctions of the members will be drilled in position to ensure absolute accuracy of workmanship. In this shop will be mounted two 150-ton electric overhead travelling cranes, and after the bridge members have been finally completed, the cranes will lift the members in their complete finished conditions and lengths, direct to barges designed for the purpose. These barges will be run into a dock which will be constructed within the width of the shop, so that the overhead electric cranes have complete command of the dock area. After the bridge members are on board, the barges will be towed into position in the harbour right under the erection cranes working at the bridge, thus reducing the amount of handling to a minimum.





*“Two workshops – one light, the other heavy, were constructed on the north side by excavating the cliffs (34Kcm) to create flat land for the workshops and new wharves for steel deliveries from England and Australia”*

**RE: excerpt from *Building the Sydney Harbour Bridge***

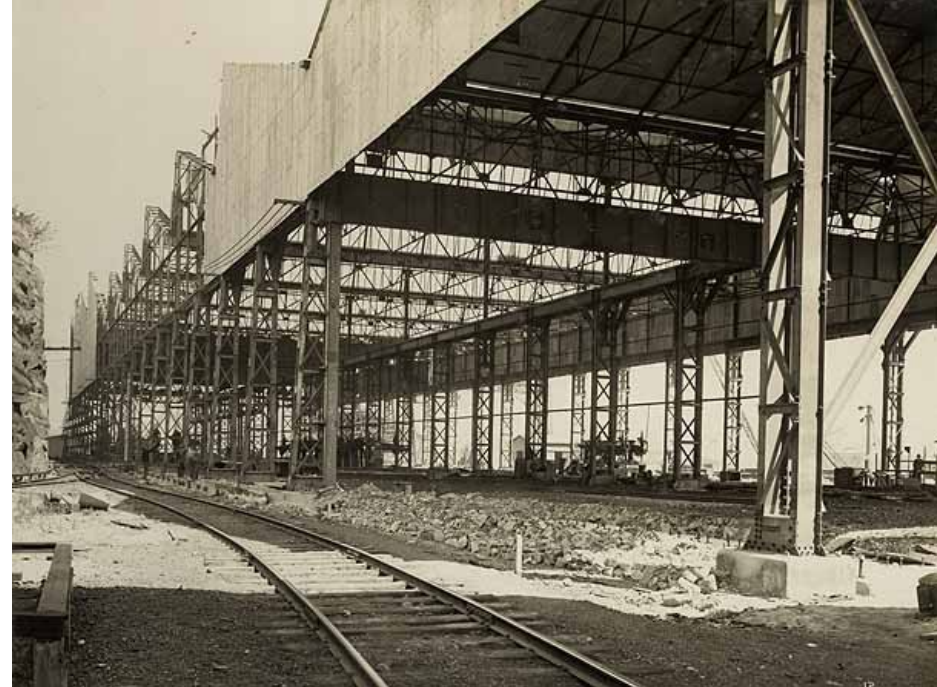

**Milsons Point site leveled and cleared (left)  
Workshops under construction (right)**

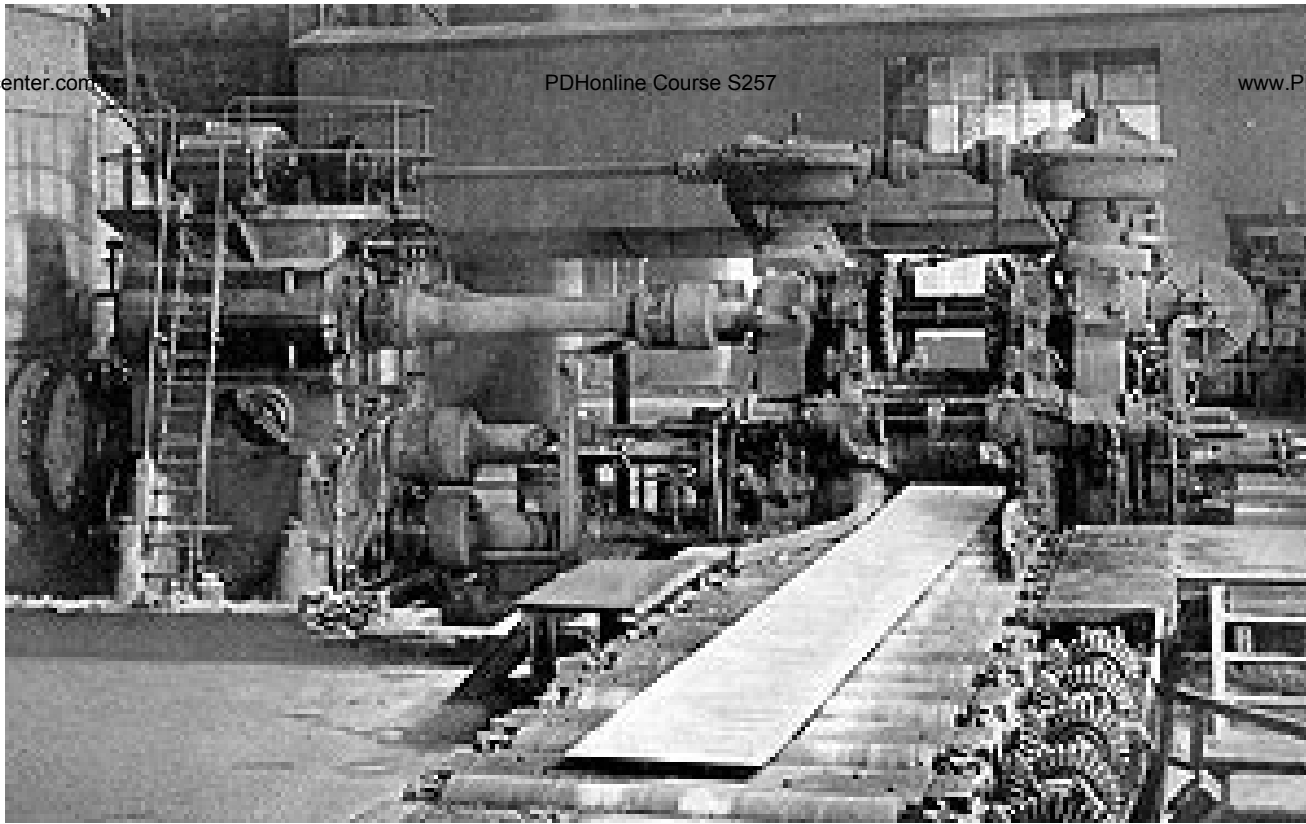

**Plate Rolling Mill – Dorman, Long & Co., Middlesbrough**  
Approximately 14% of the steel used on SHB was produced by *BHP* at their Newcastle works, the rest was furnished by Dorman, Long at their Middlesbrough plant. Plate, beams, rod etc. were hot-rolled to shape (in the bloom mill) and then shipped to Milsons Point, Sydney. Upon arrival, they were sorted and transported to the work shops and from there, the steel was cut, drilled, planed, reamed etc.

*“...It was a condition of the tender that the steelwork should be fabricated on the spot at Sydney, thus providing employment for Australian labour. Dorman, Long & Co. therefore erected extensive workshops on a site at Milsons Point, near the north end of the new bridge. The two main workshops, known respectively as the ‘light’ and ‘heavy’ shops from the nature of the work undertaken in them, were each some 500-feet long by 150-feet wide. Their equipment comprised electric traveling cranes capable of hoisting 120-tons each (some of the heavier portions of the bridge required two such cranes to handle them effectively), planing machines able to edge-plane plates more than 60-feet long, a wall-planing machine able to finish surfaces 12-feet by 10-feet, a plate-straightening machine able to tackle pieces 12-feet wide and 2¼-inches thick, high-speed drills, and all the thousand and one special items of machinery required for a modern engineering work of first-class importance...”*

*Wonders of World Engineering, 1938*





*“...After a journey of some 12,000 miles, the components of the great bridge, produced at Middlesbrough, arrived at Milsons Point in the form of steel plates and bars. The total weight of steel to be worked into the huge structure was 51,000-tons, of which 38,000-tons were required for the main arch...”*

*Wonders of World Engineering, 1938*

*“...Apart from a small amount bought from an Australian firm, and a few special pieces such as the main bearings of the arch, the whole was manufactured by Dorman, Long & Co. from their own raw materials. Once on the spot the material was straightened, planed, finished, drilled and rapidly built into an endless series of intricate components, all destined to form part of one great whole, remarkably alike for its huge size and for the accurate finish and fitting of even its smallest parts..”*

*Wonders of World Engineering, 1938*



## **Horseshoe Hydraulic Riveter (weighs 12-tons and exerts a force of 95-tons on each rivet)**

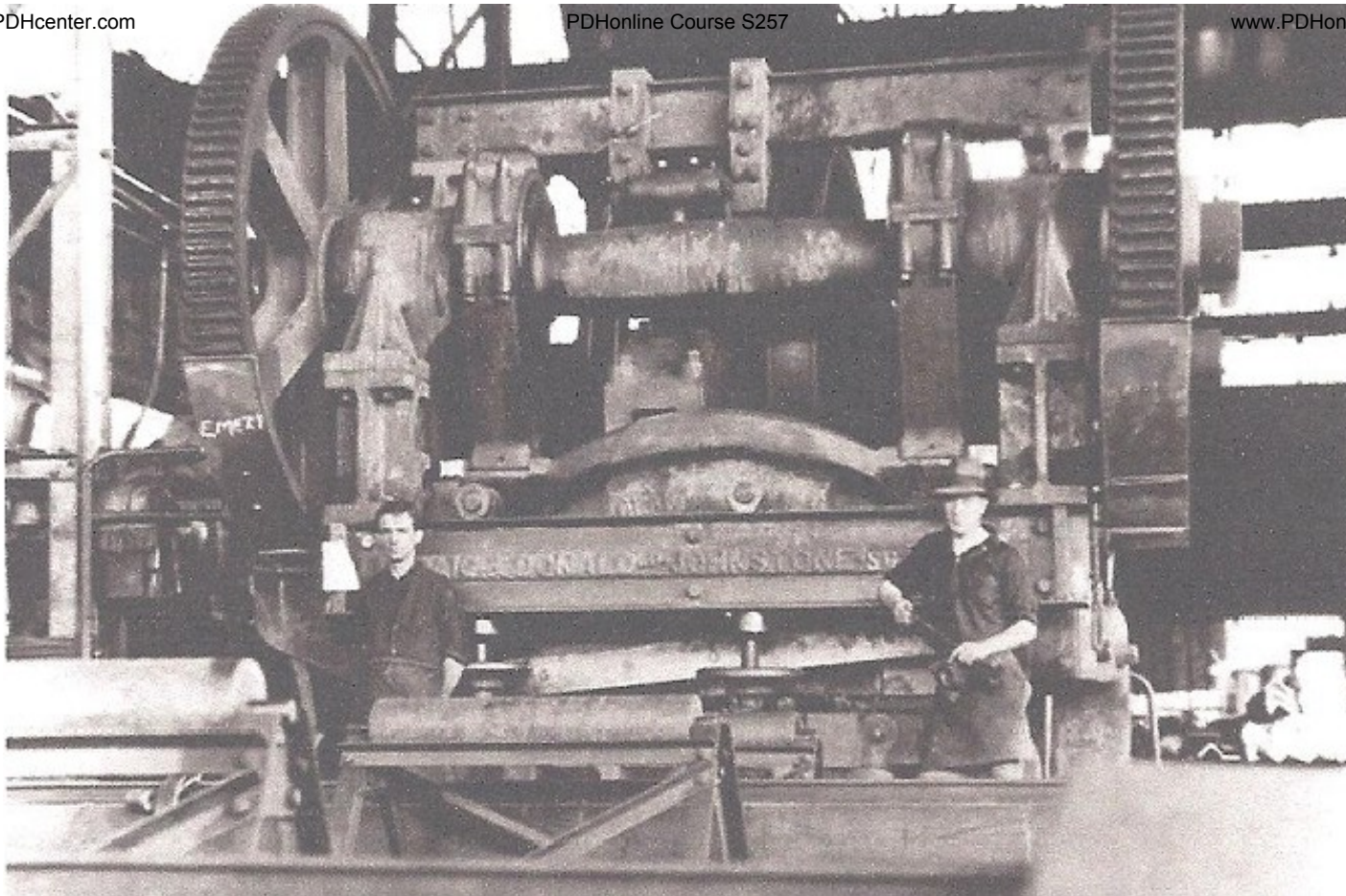

## **“The Yank”**

**Used by boilermakers (in the Light Workshop) to cut and edge steel plates prior to locating/drilling holes**



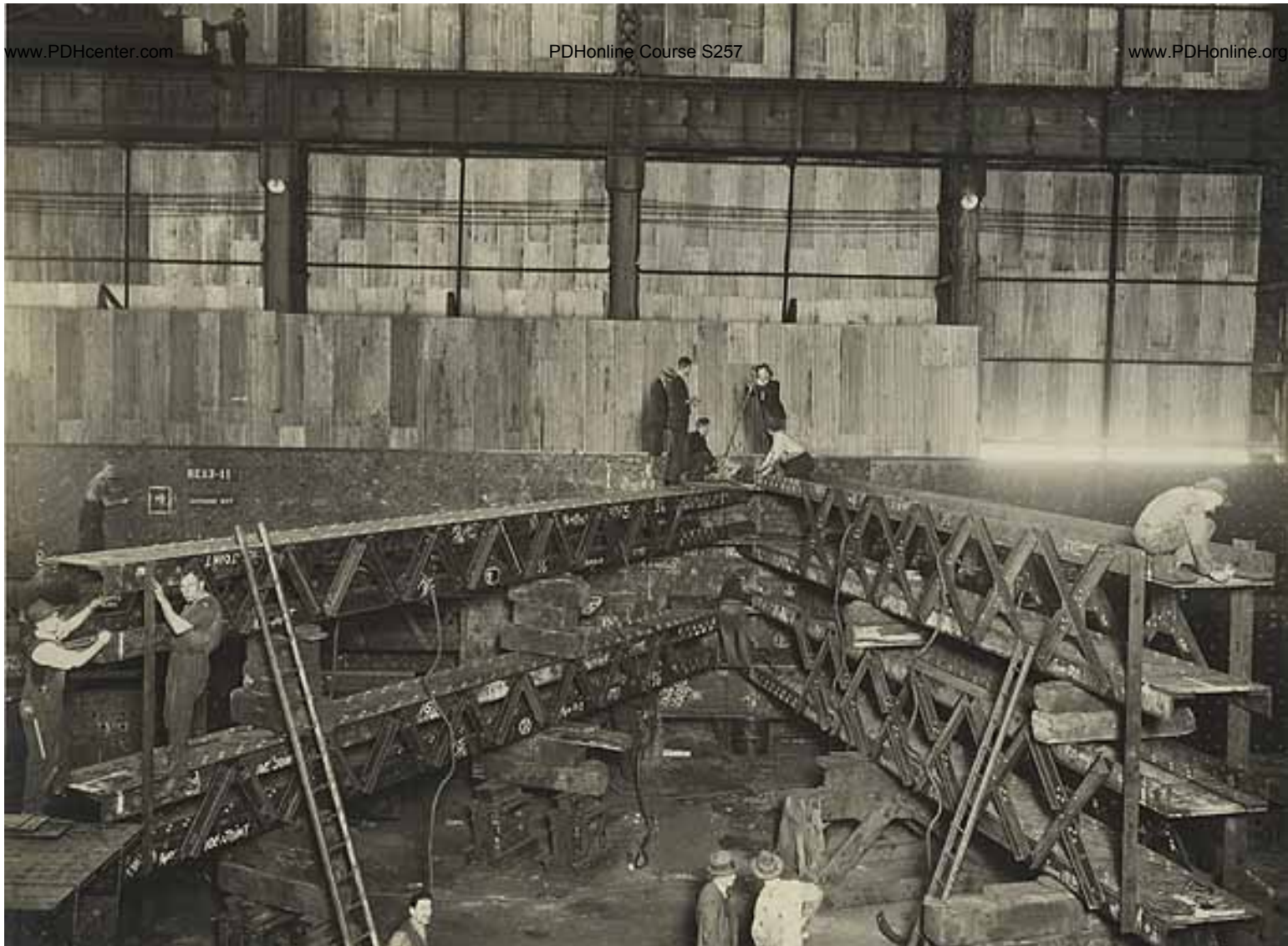

**Assembly of “Joint 13” - April 15, 1930  
(Heavy Workshop)**

# Part 6

# The Coat Hanger

# STEEL

*“...and steel man’s masterpiece, the strongest and most reliable material yet manufactured by him”*

**JJC Bradfield - Chief Engineer, SHB**



...All main members of the arch trusses, the larger sections of the lower lateral system, hangers and flanges of arch cross-girders are of silicon steel. The remainder of the deck and lateral systems are of carbon steel.

**RE: excerpt from *Sydney Harbour Bridge: Report on Tenders***

**Except for the skewbacks, pylons and approach support piers, SHB is made, primarily, of steel with the great arch carrying the live, dead, wind and impact loads of the main span. Rather than using mild or plain-carbon steel, to achieve maximum strength Dorman, Long used *silicon-steel* (the precursor to modern-day structural steel). The silicon steel was cast in ingots then hot-rolled to the required shape and thickness in sections at plants in England. In the Milsons Point workshops beams, chords etc. were fabricated from the hot-rolled sections via riveting. Large planing machines were used in the workshops to “true-up” the edges and ends of beams to ensure dimensional stability. The fabricated sections were then pre-assembled in the workshops and brought to the bridge for installation-in-place (also via riveting).**

Plain (low carbon-content) carbon steels (i.e. *Mild Steel*) typically contain much *Ferrite* whose characteristics are low-strength, softness, ductile and made of nearly pure iron (with a miniscule amount of carbon dissolved in it). In the annealed state, mild steel is about 75% Ferrite and 25% *Pearlite*. Unlike Ferrite, the properties of Pearlite are hardness, toughness and high-strength. Pearlite consists of low-strength Ferrite and a hard, iron-carbon compound known as *Cementite* (laminated together in overlapping layers). SHB used *Silicon Steel* (for the critical components of the arch and deck) which contains more carbon (0.38%) than Mild Steel (0-2%). By comparison, Silicon Steel is about 47% Pearlite and 52% Ferrite. Aside from the greater proportion of Pearlite, the silicon steel used on SHB contains 0.2% Silicon and 0.9% Manganese. These metals dissolve in the Ferrite increasing strength via a process known as *Solid Solution Hardening*. Furthermore, the hot-rolling process causes a horizontal alignment of the Pearlite both “normalizing” and refining the microstructure of the steel.

# CORROSION



**Unlike many other metals, steel does not possess *Passivity*. This term is a reference to the reaction of a metal or alloy to atmospheric oxygen. When passivity occurs, a non-porous oxide film coats the surface thus preventing *Oxidation* (corrosion). Ironically, widely used structural steel (an alloy) – which does not exhibit passivity, is most vulnerable to oxidation and must be protected. Steel oxidizes to form rust – a corrosive that is porous, thus exposing even more steel to oxidation. On large surface areas of steel, the surface corrosion is more an aesthetic problem than a structural one. On the other hand, in places where liquid water can pool and/or seep into (like riveted connections), lack-of-passivity can/does become a major problem for riveted structures like SHB.**

***Crevice Corrosion*** ensues when water is allowed to pool via a small gap or cavity, forming a ***Concentration Cell***. Water, being a fluid that conducts electricity (via a current), converts the concentration cell into an ***Electrolyte*** (oxygen concentration). If there is a high level of oxygen, the cell becomes a ***Cathode***, in low aeration, the cell becomes an ***Anode***.

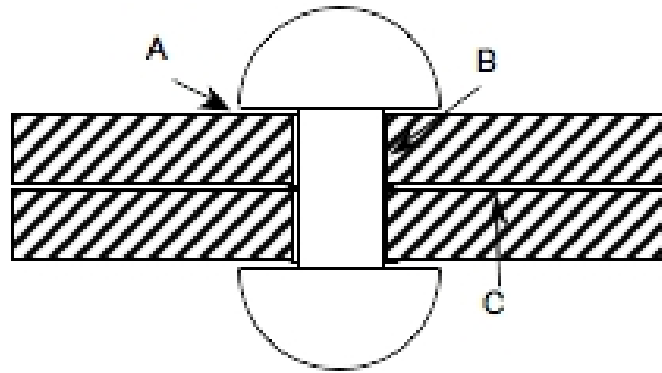

Differentials in aeration levels cause corrosion (electrolysis). Gaps in rivet heads, stems, joints (A thru C in the diagram above) are thus highly conducive to Crevice Corrosion (varying aeration levels). ***Iron Oxide*** (the corrosion product) increases volume and takes up a greater space than the original metal. As such, as the concentration cell grows forces develop that undermine the integrity of the riveted joint. Very often, corrosion is hidden from view (i.e. between joined plates). SHB was painted with a ***Lead-Oxide*** based primer and a ***Micaceous Iron-Oxide*** finish coat (to protect the steel from oxidation). Unfortunately, paint degrades due to UV light exposure and must be constantly maintained.



## **SHB painting crew, March 1932**

**272K-liters of paint were required for the initial 3-coats of paint. From scaffolding, suspended cages and bosun's chairs, the crew took a full year to apply the first coat to the 485K square meters of steel finishing on August 31, 1931. The second coat was completed (in record time) for the bridge's grand opening.**



**On February 9, 1932, this photograph of a SHB painter (hanging on by his fingernails) appeared in the *Labor Daily*. The caption read: “*Where nerve is needed*” (the photo was later used in an advertisement for “nerve tonic”). Aside from falling to their death from great height, the paint itself was dangerous. Composed of pure white lead, linseed oil and vegetable black, it’s odor was so offensive to be nauseating.**



# RIVETS

Erection riveting will proceed on the lower chord members of the main arch where the condition of the structure is practically identical as a cantilever with its condition as an arch. The erection rivets of the remaining steel members will be deferred until the arch structure is complete. Each portion of the lower chord will be planed at the ends to bear on the middle third only so that bearing on the edges is precluded, and when erection is complete the joints will have taken up the gap remaining in the outer thirds, and riveting may proceed under dead load conditions.

**RE: excerpt from *Sydney Harbour Bridge: Report on Tenders***

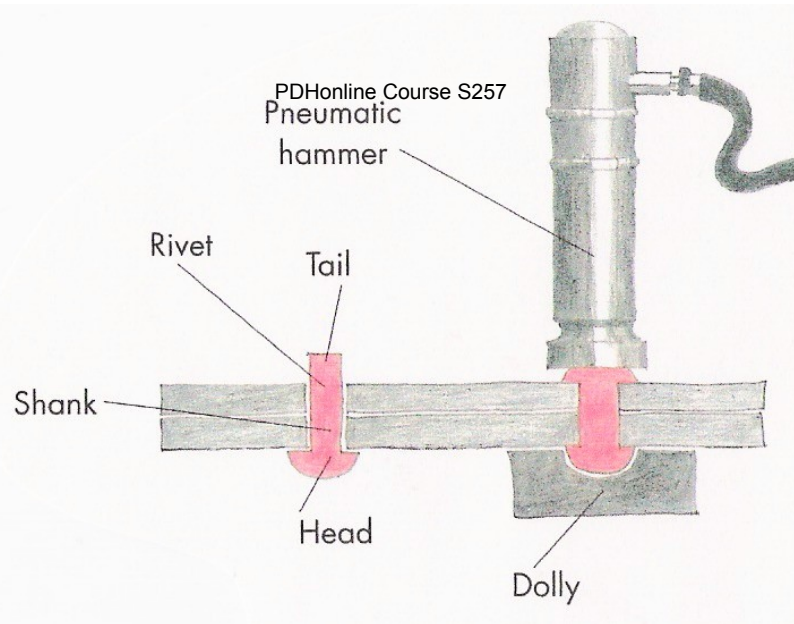

*“At the time, welding steel was considered unreliable and nuts & bolts were too expensive to use everywhere so they were used and reused to start each connection. Rivets were used throughout the SHB to hold it all together. A “dolly” – a specially shaped block, is held on one side over the head of the rivet while another man uses a pneumatic hammer to form the “tail” of the rivet into a mushroom shape (like the head). A “cooker” heated the rivets to white-hot in a small, portable oil-fired oven then tossed the rivet to a “catcher” for the “boilermakers” to install it in place.”*

**RE: excerpt from: *Building the Sydney Harbour Bridge***

Approximately six million rivets were used to assemble SHB (some where as long as fifteen inches). To do the job right, *McPherson P/L* of Melbourne manufactured the structural rivets using mild steel with a UTS (Ultimate Tensile Strength) of 413-482 MPa and a high shear strength. As for the approach steel (trusses), mild steel (with about 20% Pearlite content) was used to forge the rivets. “Hot forging” was the method by which the rivets were typically installed. Each rivet was heated in an open stove until it was “white hot” (+/-800-degrees). Having a headless shank and one mushroom-shaped head, the hot rivet was inserted into the matching, pre-drilled holes of the steel to be joined and (while the mushroom head is held in place) with a pneumatic hammer (100psi) the shank is pounded-down to a matching mushroom head. As the rivet cools, it draws the steel closer together. This method results in a favorable grain pattern (around the mushroom head/s) thus eliminating weak spots.

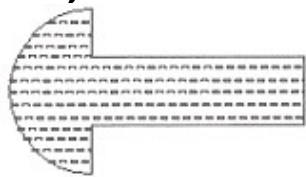

**Before Hot Forging**

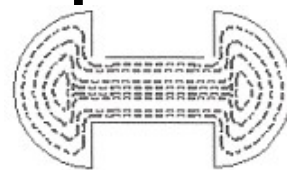

**After Hot Forging**





**Heating a rivet to “white hot” (in an oven) and passing to boilermaker  
(inside chord/s) pneumatically  
via flexible metal tubing**

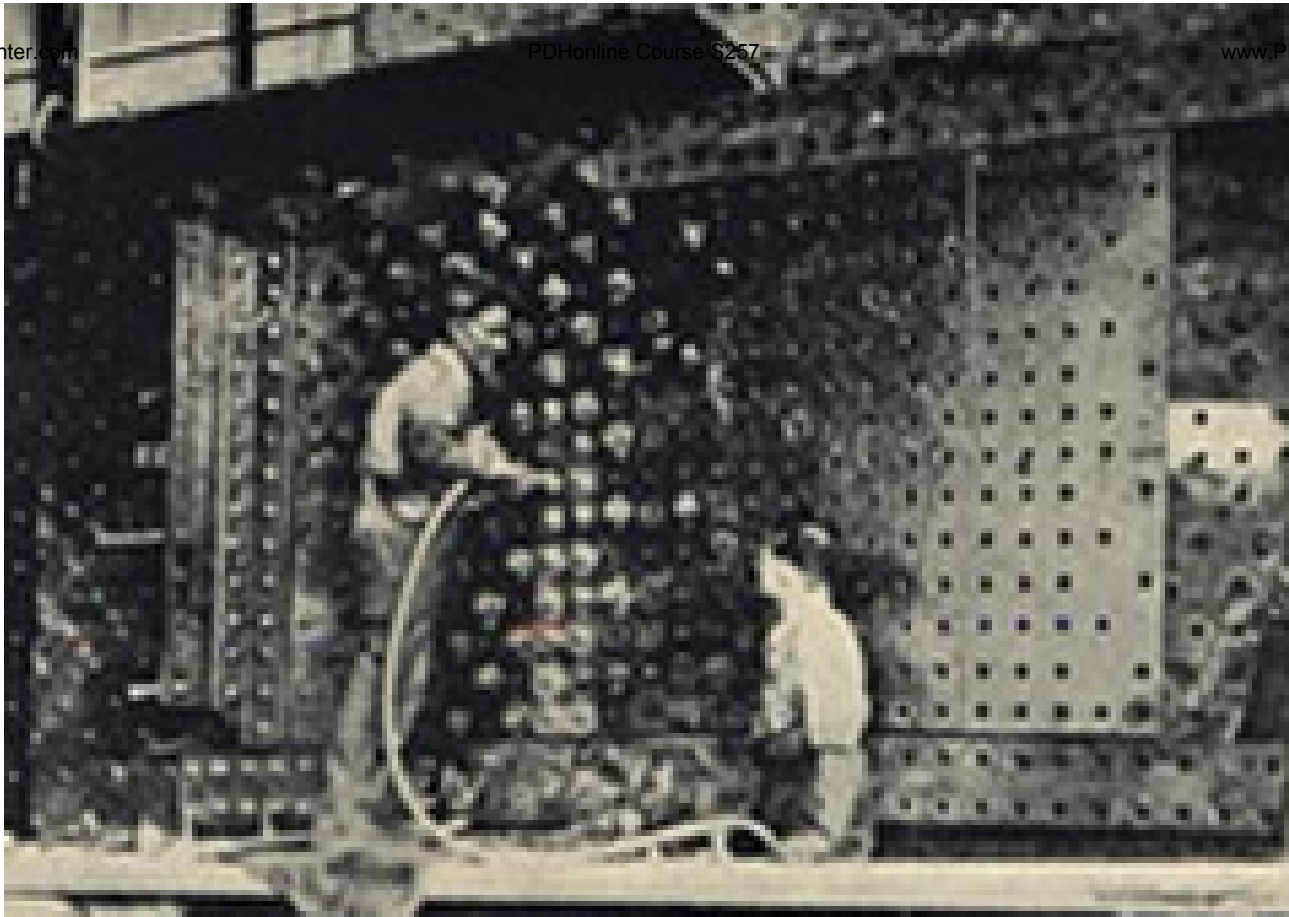

## **Boilermaker Team**

**The “Hammer-Man” (using his pneumatic hammer/gun) and the “Bucker-Up” (holding the mushroom head tight to the backside of the steel with his “Dolly”) while the gun pounds-down the end of the shank (to match the mushroom head on the other end)<sup>268</sup>**

*“They didn’t really need a bridge because you could walk all the way across the harbour on dumped steel”*

**RE: the practice of dumping steelwork and rivets in the harbor channel below the arch. A total of 101,599 rivets were rejected by JJC Bradfield and his team of inspectors.**

# TESTING



**To ensure the quality of the steel used on SHB, laboratory tests were conducted to measure both the tensile and/or compressive strength of the structural steel components. After the bridge was completed, it was load-tested for stress. These severe tests would determine any excessive stress in individual and/or groups of members during the bridge's expected life-span (1K years).**

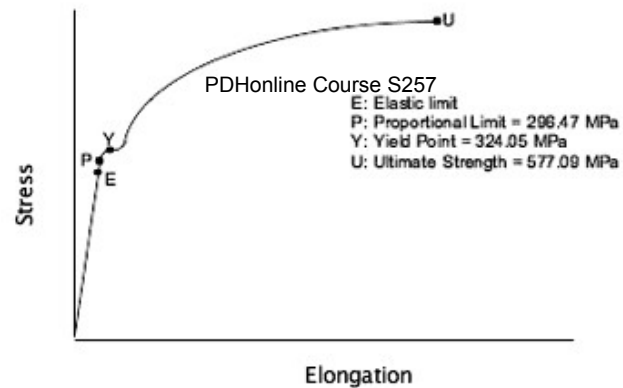

The graph above represents a *Stress-Elongation Curve* (a tensile test to failure) of a sample specimen of Silicon Steel used on SHB. The characteristic “necking” behavior of steel at *Yield Point* “Y” (324.05 MPa) is indicated as well as the *Elastic Limit* (E), *Proportional Limit* “P” (296.47 MPa) and *Ultimate Strength* “U” (577.09 MPa). With a UTS >577 MPa, the silicon steel tested is significantly stronger than 1020 Mild Steel whose UTS is 420 MPa. When the cylindrical test specimen reaches its yield point (Y), it suddenly stretched and narrowed for a short length without any additional load applied. As load is continuously applied (Y to U), the test specimen elongated until failure at point U (its UTS). The breaking point released stored energy in the form of a loud bang, akin to a large gun being fired indoors.

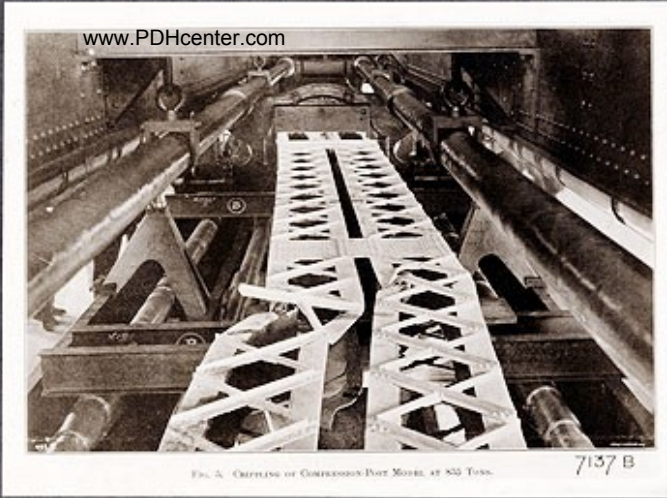
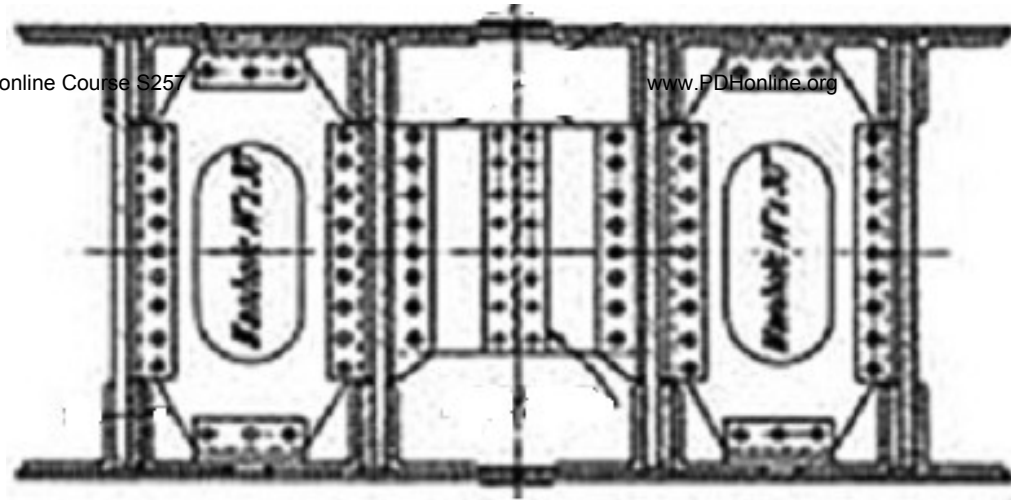

FIG. 5. OUTLINE OF COMPRESSION-TEST MODEL, 48 5/8 TONS. 7137 B

THE AVERY 1250 TONS HORIZONTAL UNIVERSAL TESTING MACHINE.  
THE LARGEST OF ITS KIND IN THE WORLD.

B.002



## Upper-Chord Section

The main span of SHB consists of twin arches composed of chord beams loaded in compression (right). To ensure that these beams could/would withstand the applied loads, scale-model beams were fabricated using the same criteria as the full-size beams. Using an *Avery 1250-ton Compression-Testing Machine* (left), the scaled-down beams were tested to destruction. Stress and strain values were scaled up based on the observed deformation of the models. It's typical for long, slender beams to fail by “buckling” rather than by pure compression; exactly what happened to the test models.

**When the bridge was completed, Dr. Bradfield conceived various severe loading configurations on the railway tracks using old, fully-loaded steam locomotives (and their tenders) on both the railway (western) and/or tramlines (eastern) side/s of the bridge. The design loading scenario included all roadways, footways and railways fully occupied, a hurricane-force wind of 100mph (lateral to the bridge) and a temperature variation of 120-degrees. Using reference points, surveyors measured deflection while engineers (using strain gauges) measured strain directly on and within chords, beams etc. Since (within the elastic limit) stress is directly proportional to strain, the measurable degree of deflection at any particular joint reveals the stress as well. A comparison of the observed stress and design (calculated) stress would reveal any potential areas of excessive stress. The theoretical deflections predicted in the calculations were found to be within allowable tolerances as compared with the load-test results.**





## Load-test underway



## **Gordon Stuckey – SHB Engineer (ca. 1930)**

**As head of the *Bridge Contract Section* of the NSW Dept. of Public Works, Stuckey and his crew of engineers established erection schemes (for the main arch span, approach spans and pylons), checked drawings and calculations and stress-tested the steel. His 10 to 15 young, enthusiastic engineers were all over the bridge; measuring rivet holes and joints for deformation and using strain gauges during load-tests.**





**Engineers using strain gauges (within lower-chord)**

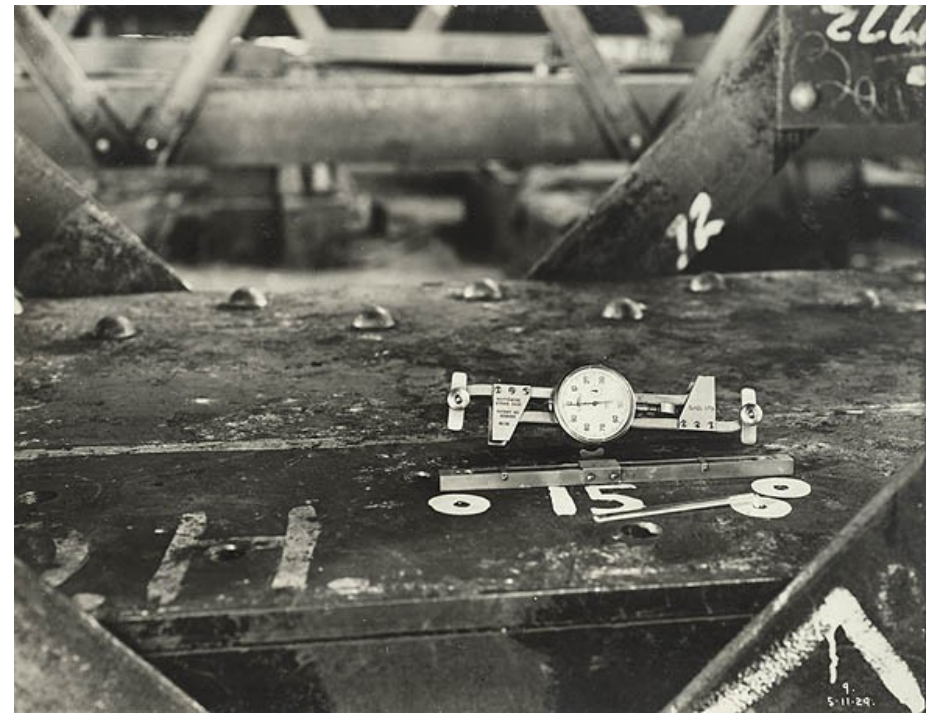

## Strain Gauges



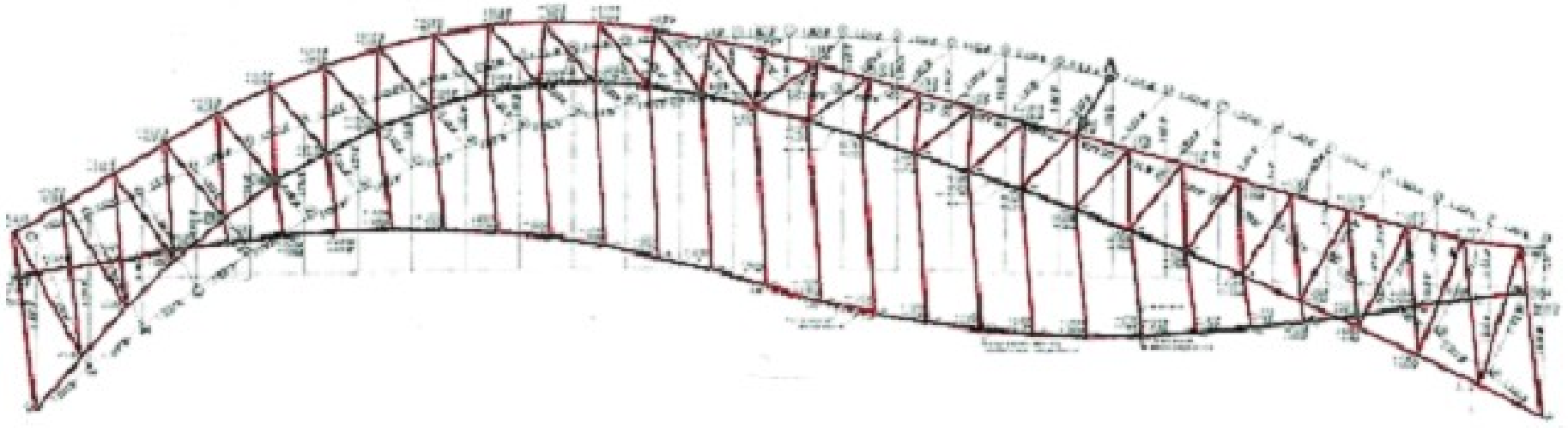

**Magnified 120x (the main scale of the arch drawing), this diagram exaggerates the deflection of the arch caused by *Loading Arrangement No. 2*. In this scenario, the northern half of SHB was fully loaded while the southern half was left unloaded. The largest deflection measured was 183mm (downward).**

# ARCH

The main arch trusses are set in vertical planes, and are spaced 98 feet 6 inches centre to centre, with parabolic lower chords of 1,650 feet span and 350 feet rise from centres of bearings. At the crown the depth is 60 feet, which increases by means of a parabolic top chord and a slight reverse at each end to 190 feet over the main bearings. The highest point of the top chord is 445.48 feet above high-water level of the harbour. Each of the bearings is 38 feet to centre above standard datum or 35.48 feet above high-water level, and is designed to carry the inclined thrust of the arch trusses.

**RE: excerpt from: *Sydney Harbour Bridge: Report on Tenders***

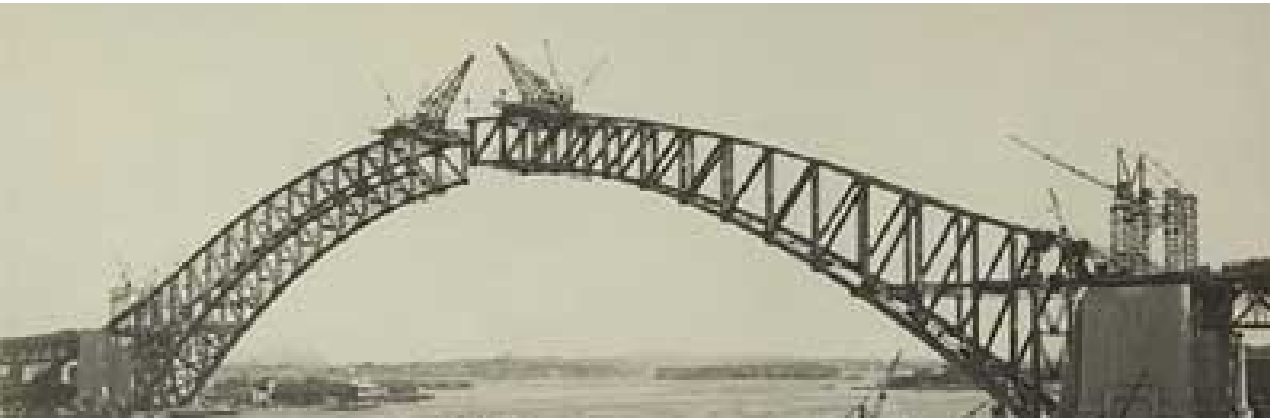

***“An arch is two  
weaknesses  
which, together,  
make a strength”  
Leonardo DaVinci***



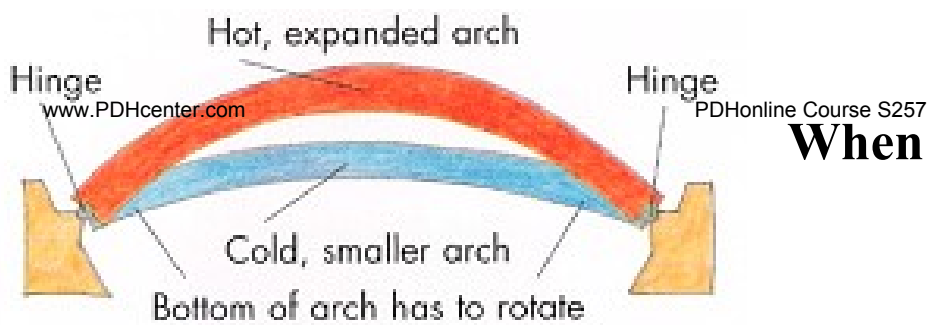

www.PDHonline.org

**When it gets hot, the top of the arch can rise & fall +/-180mm**

*“...A leading feature of the design is that the whole weight and thrust of the gigantic arch are transmitted to its piers through four enormous hinges, one at either end of the two lower chords. Mounted in this manner, the arch is free to rise in the centre when expanded by heat – a necessary precaution in a metal structure of such enormous size. The amount of expansion is much greater than might be imagined. The total length of the whole bridge, from one end to the other (approximately 3,770-feet) is roughly a foot greater by day than at night, and special expansion joints are fitted at intervals along this length to allow for expansion. It has, however, little effect upon the height of the trackway above the water, as the upward lift of the arch is largely neutralized by the downward expansion of the vertical hangers by which the trackway is suspended...”*

*Wonders of World Engineering, 1938*



**Expansion joint in approach span roadway deck**

**Considered in the SHB design specification was the thermal expansion of the bridge's assorted components and the differential in expansion between different materials and components. A variable range of 28-degrees centigrade - between the temperature of the steel and the masonry, and 67-degrees centigrade - in the uniform temperature of the entire structure, was assumed.**

Each main truss consists of two main chords divided into 28 panels of 58 feet  $11\frac{5}{32}$  inches, by a single system of bracing. Lateral bracing consists of double diagonals and struts on top and bottom chords, with a portal frame between end posts and a portal bay in the lower lateral frame where the floor intersects the plane of the lower chords. From the abutments to near the quarter points, the lateral members in both systems are riveted to the chords, but between these points, where relative deflections of the trusses under unsymmetrical live load are appreciable, pin connections are used at the ends, permitting rotation in a vertical plane parallel to the axis of the member.

**RE: excerpt from: *Sydney Harbour Bridge: Report on Tenders***





*“...The main arch is really two arches side-by-side, exactly parallel, 98-feet apart, and connected by cross-girders. Each of these arches consists of an upper and a lower member (termed the ‘upper and lower chords,’ although each is really a series of short chords along an enormous imaginary arc) formed of tubular box-girders, and connected by vertical struts (open lattice-work girders)...”*

*Wonders of World Engineering, 1938*

Every main chord member of the trusses consists of a built-up section composed of four web plates and sixteen flange angles 10 inches by 10 inches, together with flange plates forming a rectangular box section. Vertical and diagonal main truss members are composed of four web plates with eight flange angles 8 inches by 8 inches and lattice bracing suitably proportioned. Webs of all members are spaced to allow about 30 inches clear. Main top chord members are 40 inches deep throughout and 10 feet 6 inches wide across the flanges with webs varying from  $1\frac{7}{8}$  inches to  $1\frac{3}{4}$  inches thick. The depth of bottom chords varies from 48 inches to 108 inches, and the thickness of webs from  $2\frac{3}{4}$  inches to  $4\frac{1}{2}$  inches, the width being the same as the top chord. The greatest thickness of any individual web plate is  $2\frac{1}{2}$  inches with rivets of  $1\frac{1}{4}$  inches maximum diameter. All chord sections are stiffened with transverse diaphragm plates on each side of connections and erection joints. Manholes and openings in diaphragms provide access to each compartment of the chords. The weight of each panel section of the bottom chord varies from 112 tons at the crown to 370 tons at the abutment.

**RE: excerpt from: *Sydney Harbour Bridge: Report on Tenders***



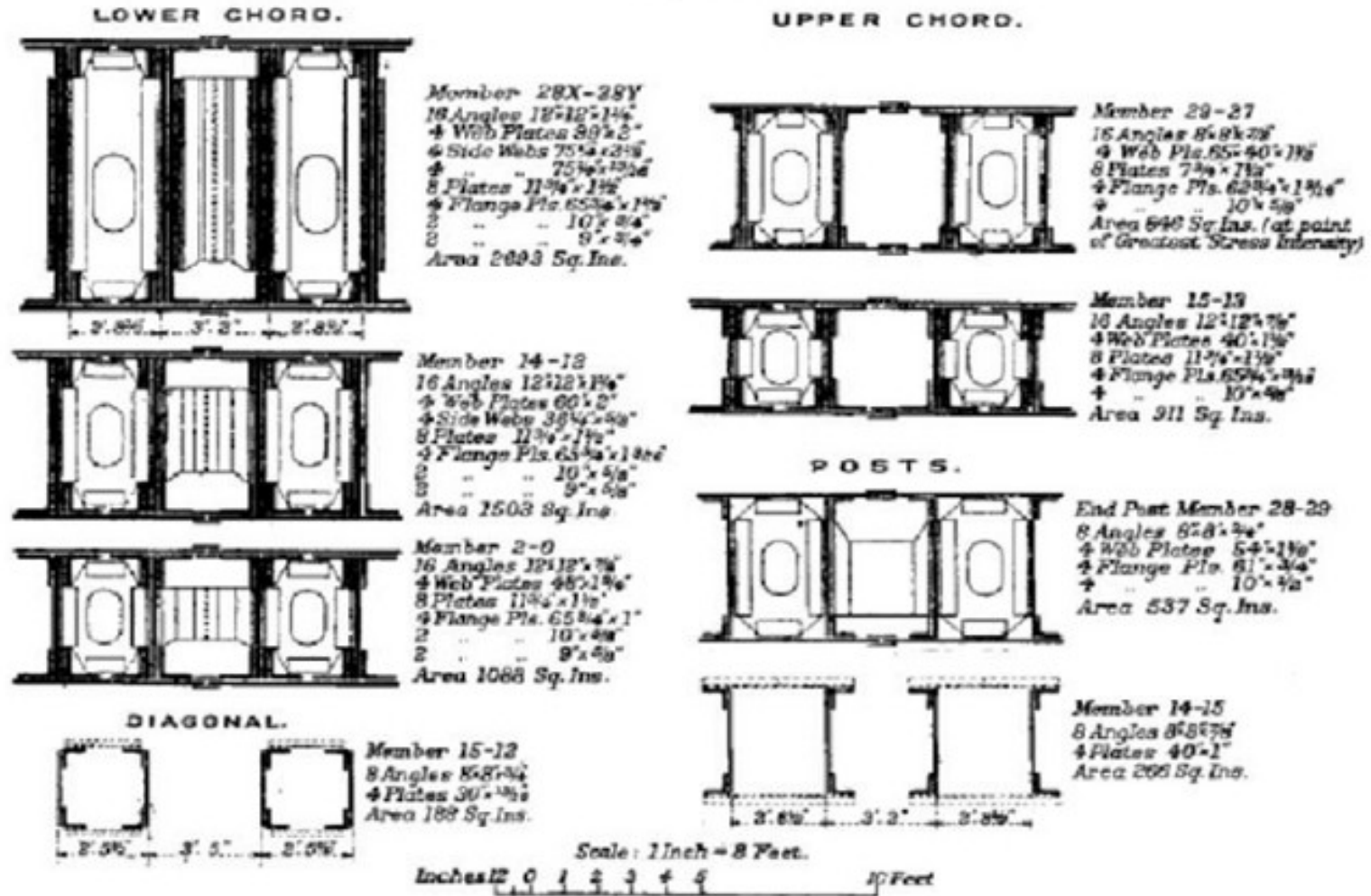

TYPICAL CROSS SECTIONS OF MEMBERS.

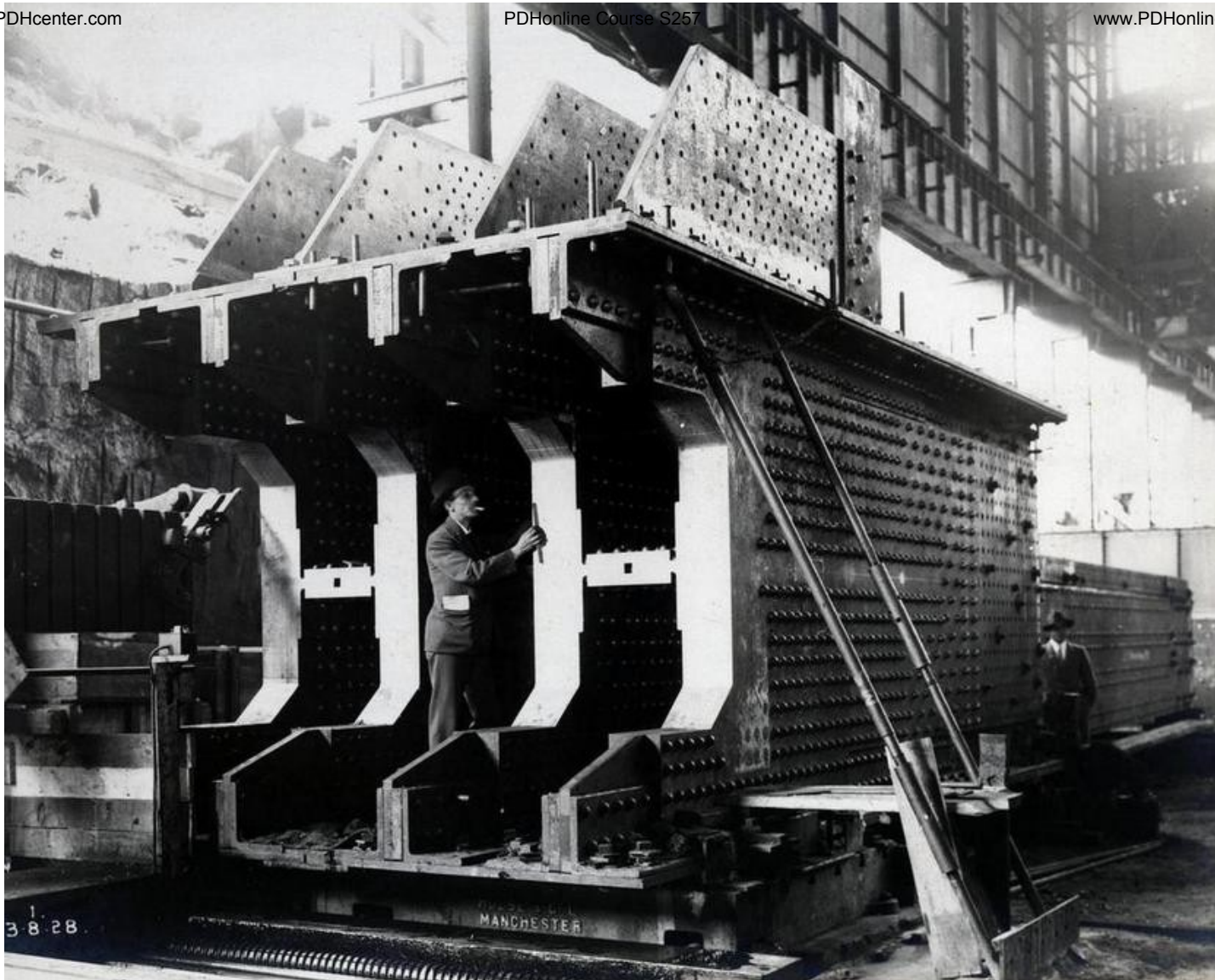

## Lower Chord Section





www.PDHcenter.com

PDHonline Course S257

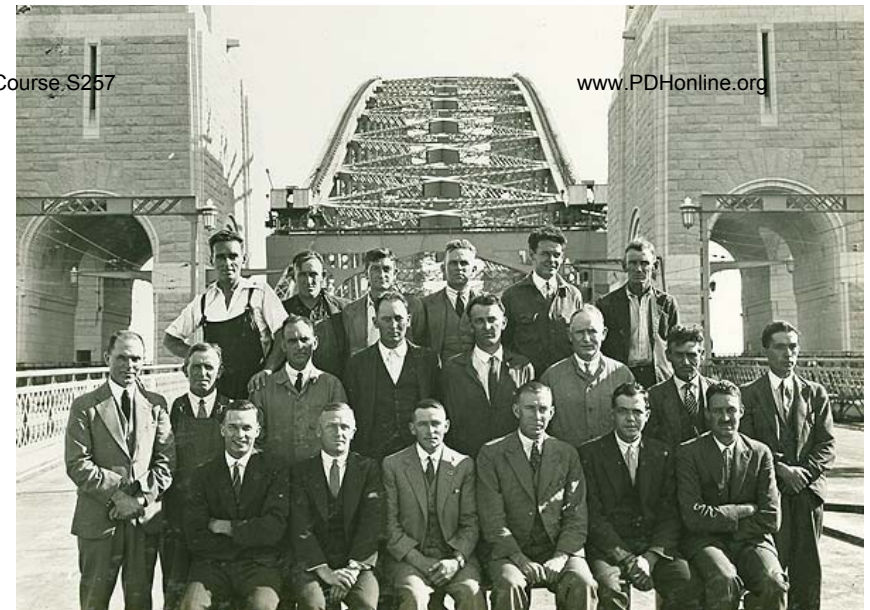

www.PDHonline.org

***“Ralph Freeman and his team of engineers had to calculate the size of each piece of steel in the bridge, not just once, but three times. They had to ensure the structure would hold up:***

- 1. When it was held back by the cables, and the steelwork was ‘cantilevered’ over the harbour;**
- 2. For that short period when only the bottom chords were leaning against each other;**
- 3. When both top and bottom chords were rigidly joined, and the load of the deck and traffic was added.”**

**RE: excerpt from: *Building the Sydney Harbour Bridge***



*“...These vertical struts, which gradually diminish in height from 188-feet at the abutments of the arches to 60-feet at the crowns, divide each arch into twenty-eight panels, and each panel is traversed by a diagonal strut running from the head of each vertical strut to the foot of the next innermost. Seen in profile, therefore, each arch appears to be composed of a series of huge capital Ns, gradually diminishing in size...”*

*Wonders of World Engineering, 1938*

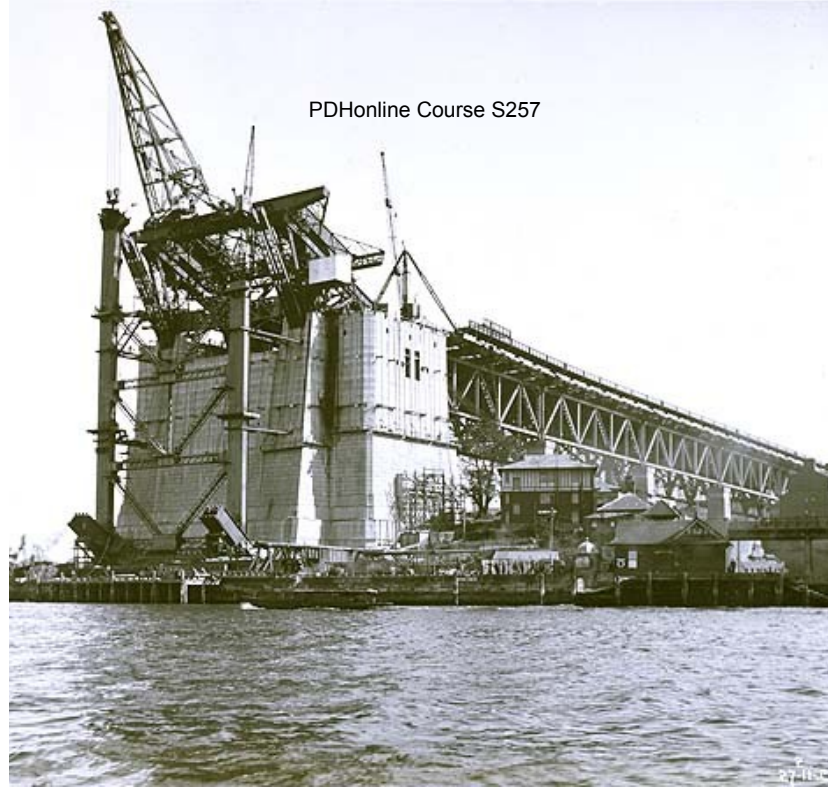

*“...Work on each half-arch was begun by getting the outermost panel into place and bolted. During this time the fabric was prevented from turning round the hinge-bearing by a set of eight temporary wire cables, anchored to the end-post a little below its head. It was impossible, at the moment, to fit the full complement of 128 cables, as their points of attachment to the end-posts were occupied by a sloping steel ramp, extending from the head of the pylon to the upper chord...”*



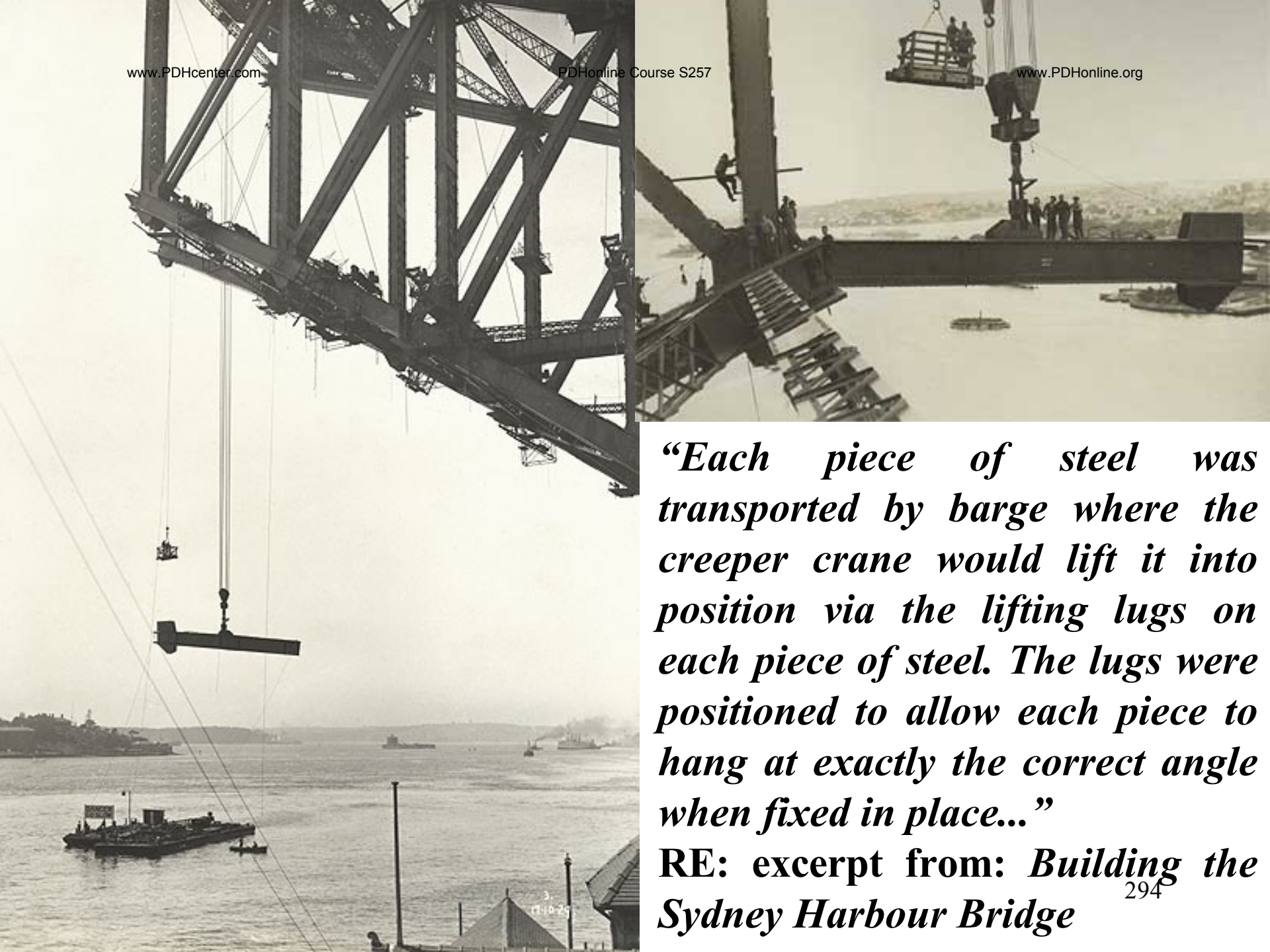

*“Each piece of steel was transported by barge where the creeper crane would lift it into position via the lifting lugs on each piece of steel. The lugs were positioned to allow each piece to hang at exactly the correct angle when fixed in place...”*

*RE: excerpt from: **Building the Sydney Harbour Bridge***







*“I saw the rivet cookers throwing the almost white-hot rivets. They flew like sparklers through the air, shedding burning scale everywhere, before landing in the catcher’s bucket”*

**Vera Dawson – Office Worker,  
Dorman, Long & Company**



**Arch erection had begun on October 26, 1928.  
By September 1929, five panels at the south end and  
one at the north end were complete.**









*“...he was bolting up stitch plates for the riveters. His long-handled spanner slipped and he went over backwards. A diver found his body later, standing upright in the mud”*

**Jack Rue**

**RE: death of a SHB bridgeworker**

*“For eight years, between 1,200 and 1,400 men were working on the bridge, in the workshops or at Moruya at any one time. Most of the steelwork was put together by about 150 riggers... The riveting in the workshops and on the bridge was done by boilermakers, aided by mates, cooks and painters (coated the rivet and any scratches that occurred in the process). Dogmen helped coordinate the hoisting of loads, sometimes riding the steel up from the barges, and communicating by telephone with the crane-drivers...Amazingly, there were only 12 officially appointed ‘steel erectors,’ six on each side of the bridge. This select band, dubbed the ‘tin hares,’ were the ones who jockeyed each steel piece into position, and fastened the first nuts and bolts into place, finely adjusting the angle and position before riveting began.”*

RE: excerpt from: *Building the Sydney Harbour Bridge*



*“Every day those men went on to the bridge, they went not knowing whether they would come down alive or not”*

**Laurence Ennis - Director of Construction, SHB**



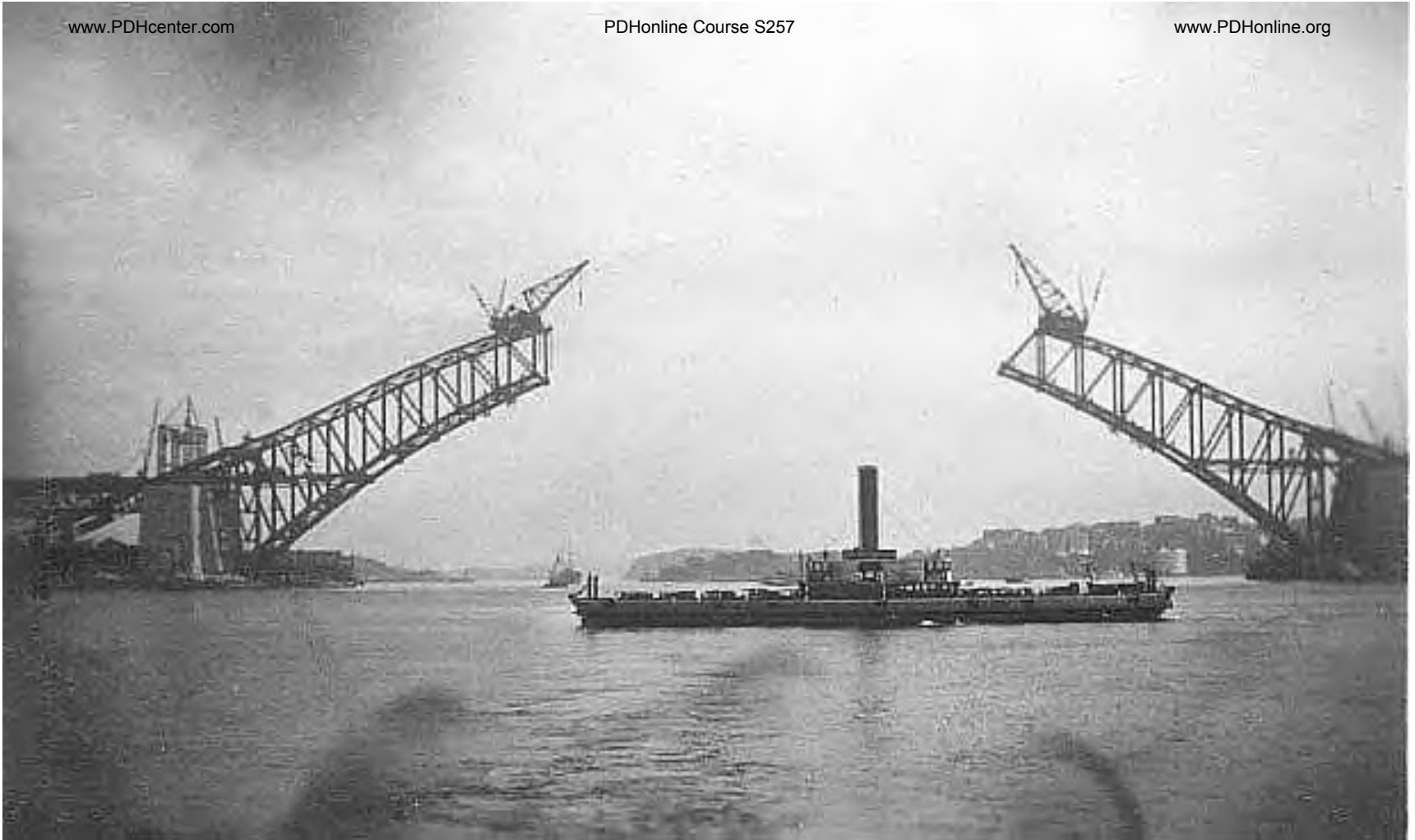

**November 26, 1929**

**A new world record is established when 589-tons of steel  
are erected in just one day**



*“...75mm diameter cables were strung diagonally across the trusses and then tensioned to reduce the significant wind-sway.”*

**RE: excerpt from: *Building the Sydney Harbour Bridge***





*“...I am often working near the edge of the bridge and on many occasions I have thought to myself ‘Now, if you ever fall, Roy, you had better make sure that you hit the water feet first or head first.’ So, when I slipped and fell today, I concentrated on saving my life. That is all I thought about. It was the only thing on my mind; the desire to live. I knew that I was very near death. I hit the water. I went under. There was a roar of water in my ears. My lungs felt as though they would burst. Then I came to the surface. I was alive, marvelously alive.”*

**Vincent Kelly – Boilermaker, SHB  
RE: survivor of a 01/31/30  
fall of 182-feet off SHB**





**There were no modern-day safety precautions taken for the workmen on SHB (i.e. nets), the men worked at their own risk in all kinds of foul weather conditions. A total of sixteen men died building the Sydney Harbor Bridge.**





*“...The meeting of the north and south portions of the arch, in August 1930, showed how accurately the work had been planned and executed. So perfectly had the alignment of the hinge-bearings been secured that the provision made for forcibly aligning the half-arches laterally by hydraulic jacks (which could eliminate divergence not exceeding 41-inches) proved superfluous...the sole observed deviation was a slight inequality in the height of the two ends above water. This was due to a difference of expansion, the sun’s heat having a greater effect upon the northern side of the arch...”*

*Wonders of World Engineering,<sup>309</sup> 1938*

***“August 1930: Both the northern & southern halves of the arch are complete – a gap of about one meter is spanned by planking. Supervising engineer Laurence Ennis is first to ‘cross’ the SHB. He gives the order to start lengthening the tie-back cables, allowing the two halves of the arch to slowly tilt towards one another. This entailed turning the 512 nuts on threaded rods at the ends of each cable a few turns at a time to loosen them. This process was repeated many times over eight days. A severe storm on August 13th causes the arches to sway in opposing directions, but the arch-halves survive this test when they are at their most vulnerable position”***

**RE: excerpt from: *Building the Sydney Harbour Bridge***





*“We were so overawed with the mightiness of it all that we did not speak”*

**Lawrence Ennis - Director of Construction, SHB**

**RE: the joining of the two half-arches (Ennis at left in photo)**

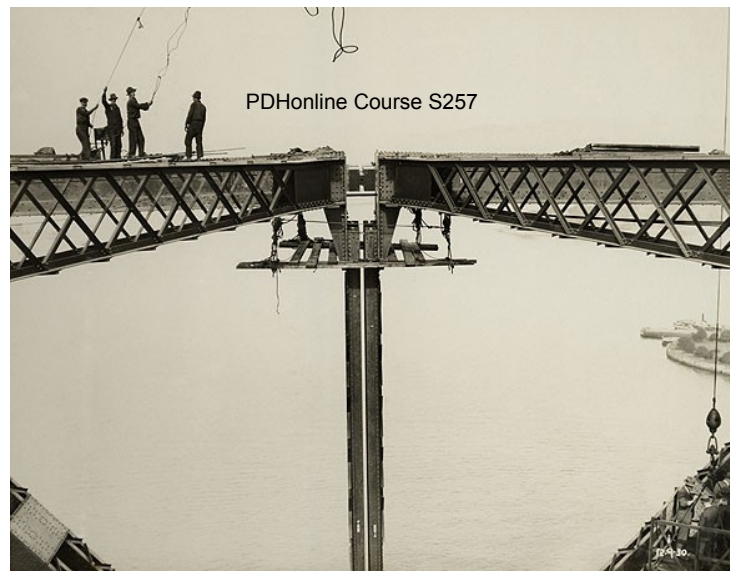

*“...The provision of the hinge-bearings at the feet of the half-arches enabled these to be moved slightly up or down, similarly to the halves of a bascule bridge. Since it was better and simpler to lower than raise them, provision had been made, when adjusting the tension of the anchorage cables, to ensure that when the half-arches were completed (at the fourteenth panels) there should be a slight gap between the two inner faces, which could be closed by slightly easing the cables. The upper ends of the outer end-posts, therefore, had been raked back slightly from the vertical – a distance of 2-feet 6-inches at a radius of 188-feet...”*



*“...It was calculated that, after having made allowance for the inevitable slight stretch of the cables under their enormous load and for the equally inevitable slight deformation of the girders as the weight came farther and farther off the line of the hinge-bearings, there would be a gap of 3-feet between the inner ends of the half-arches, with a possible variation of about a foot more or less, depending upon the temperature...”*

*Wonders of World Engineering, 1938*



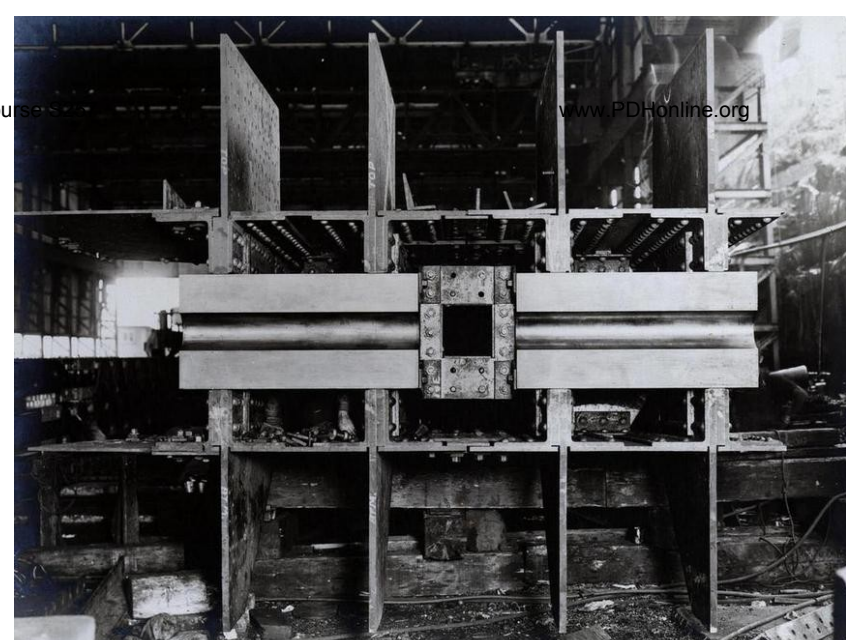
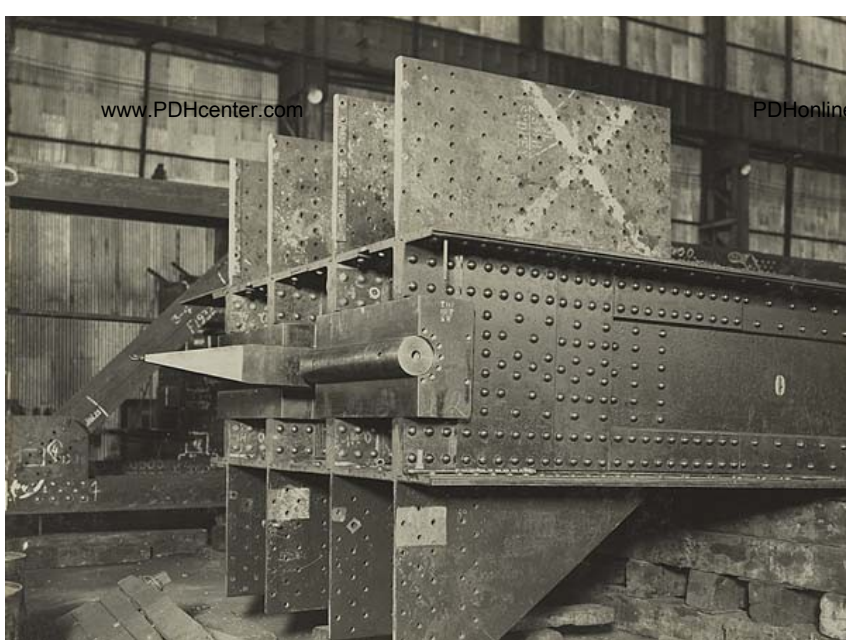

*“The bottom chords of each arch lined up almost perfectly. In order for them to meet exactly, a large, tapered guide pin with a corresponding square hole on both sides of each arch truss’ bottom chord assured that the bottom chords met in the exact position required. A horizontal, semi-circular groove and corresponding round pin at each end of the bottom chord ends acted like a third hinge-point for the bridge once the guide pin was inserted into the square holes. When joined, this bottom chord ‘hinge’ was taking almost all the load of the arch.”*

**RE: excerpt from: *Building the Sydney Harbour Bridge***



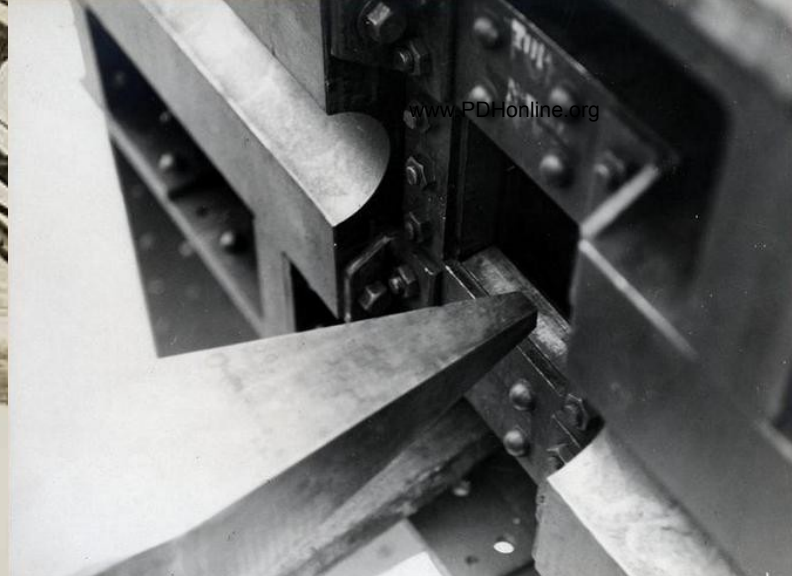

**Lower-chord locating  
pin/hinge  
(at arch center)**



*“...The gap at the summit of the arch was next closed by slacking off the anchorage cables, a delicate process which occupied a fortnight. On August 19, 1930, the hoisting of flags on the creeper-crane jibs, and an answering roar of sirens from the shipping in the harbour, indicated that the halves of the great arch were in permanent contact, and its lower chord was completed. This was effected by uniting the halves of the chord with steel pins of 8-inch diameter, forming a hinge-bearing...”*

*Wonders of World Engineering, 1938*





**Lower chord/s complete  
Temporary three-hinge arch condition  
(until top chord/s are completed)**



*“We have placed the Union Jack and the Australian Ensign at the apex of bridge building in the world. We expect future British designers and bridge builders to keep them there.”*

**Lawrence Ennis - Director of Construction, SHB**

**RE: the triumphal unfurling of the British and Australian flags from atop the boom/s of the two creeper cranes at 8:00am on August 20, 1930 (Ennis was a Scot). Many of the bridge’s workmen were WWI veterans (they were given preference for employment). At the sight of the flags unfurling, they sprang to attention and saluted.**



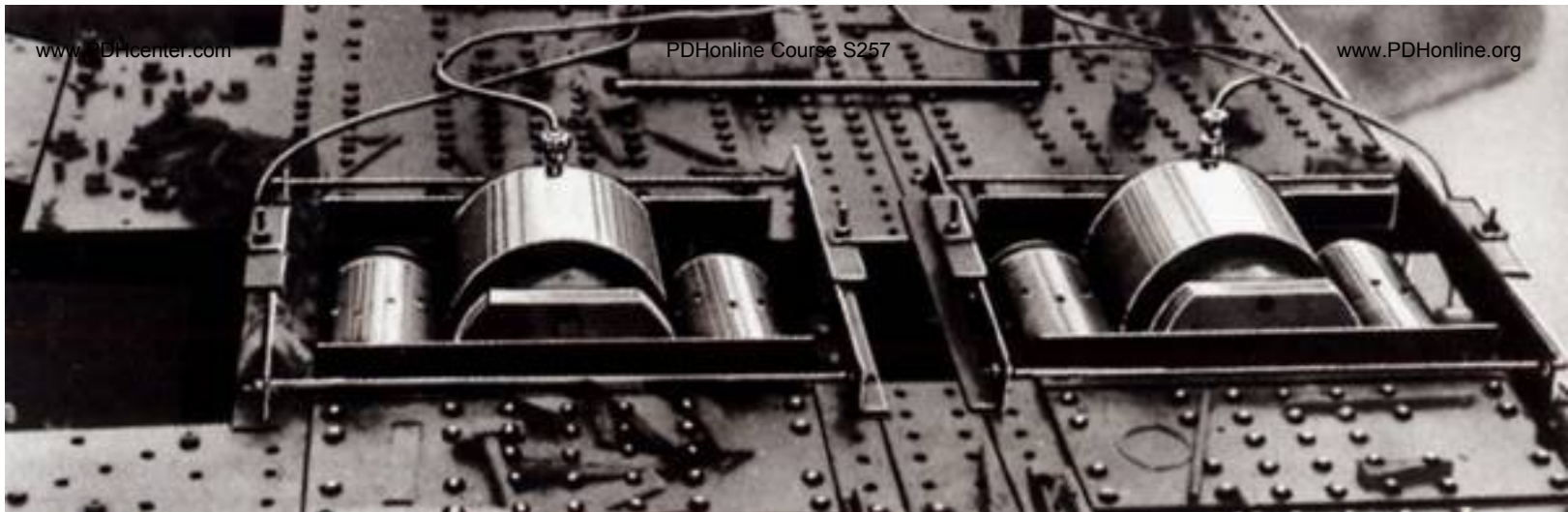

***“September 1930: The last pieces of top chord are in-place. To allow for the top chord to take its share of the load and relieve the bottom chord, pneumatic jacks - applying a pressure of 8400 tons, were placed in the gap in the top chords forcing the two halves of the arch apart. Steel packing was installed and the jacks removed thus completing the arch and returning the arch to its permanent ‘two-hinge’ state.”***

**RE: excerpt from: *Building the Sydney Harbour Bridge***



*“...The arch, however, was not yet in its final condition as a two-hinged structure. It was necessary to bring the upper chord into a state of compression. This was effected by forcing the butting faces of its two halves slightly apart by hydraulic jacks, and inserting steel filling-pieces, carefully machined to the exact thickness required. The completed joints of upper and lower chords were then covered with plating. The weight of the bridge, the main load of 28,000-tons, remained, as before, distributed over the four hinge-bearings at the extremities of the lower chord...”*

*Wonders of World Engineering, 1938*



*“...the arch was completed so as to leave a gap between the top chords of 24-inches (610mm), into which was inserted four hydraulic jacks in each chord. These eight jacks were capable of exerting a combined force of nearly 8K-tons, at an operating pressure of 4-tons per square inch. The two top chords were forced apart to a predetermined extent, and in the space carefully machined steel slabs were inserted as packing pieces. By forcing the two central top-chord members apart, the crown was made into a rigid structure, and thus into its ‘two-hinged’ condition, the main bearings alone acting as hinges”*

**Lawrence Ennis - Director of  
Construction, SHB**



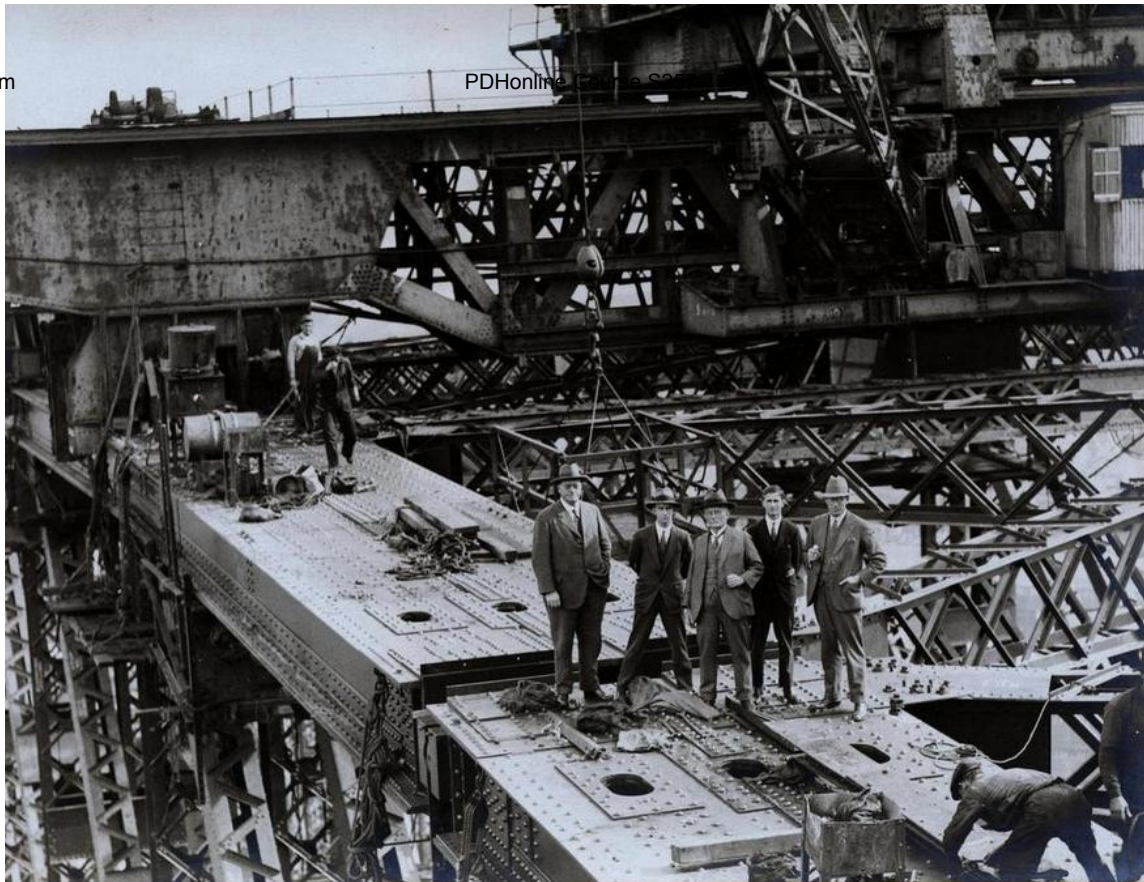

***“Thank God she’s home”***

**Lawrence Ennis - Director of Construction, SHB**

**RE: statement made at the successful joining of the top chord/s (via a steel pin) thus completing the arch on August 20, 1930. Atop center joint, top chord – from left to right: *Mr. L. Ennis, Mr. A. Bradfield, Dr. JJC Bradfield, Dr. SG Bradfield, Mr. R.J. Butler.***



# DECK

For the extent of three panels next to each main bearing the cross-girders are connected to the truss verticals by pins. Beyond these points, the cross-girders are suspended at each end from the main trusses by silicon steel hangers at each panel point. These hangers are constructed of rectangular, built-up sections, and the connections are made by means of pins. Each cross-girder consists of a double-webbed plate girder 150 feet long and 12 feet deep, into which the stringers are framed. At the point where the floor intersects the lower chord, a special cross-girder is used, hung from the lower panel point. Lateral rigidity of the floor is provided by a complete truss with wind chords and double diagonals fixed to the stringers and connected to the cross-girders. The depth of this truss is 148 feet 6 inches and it forms a cantilever system anchored at the end posts, bearing on the main truss lateral system where it intersects the lower chords, and supporting a central "suspended span" extending through the central 14 panels of the span.

**RE: excerpt from: *Sydney Harbour Bridge: Report on Tenders***

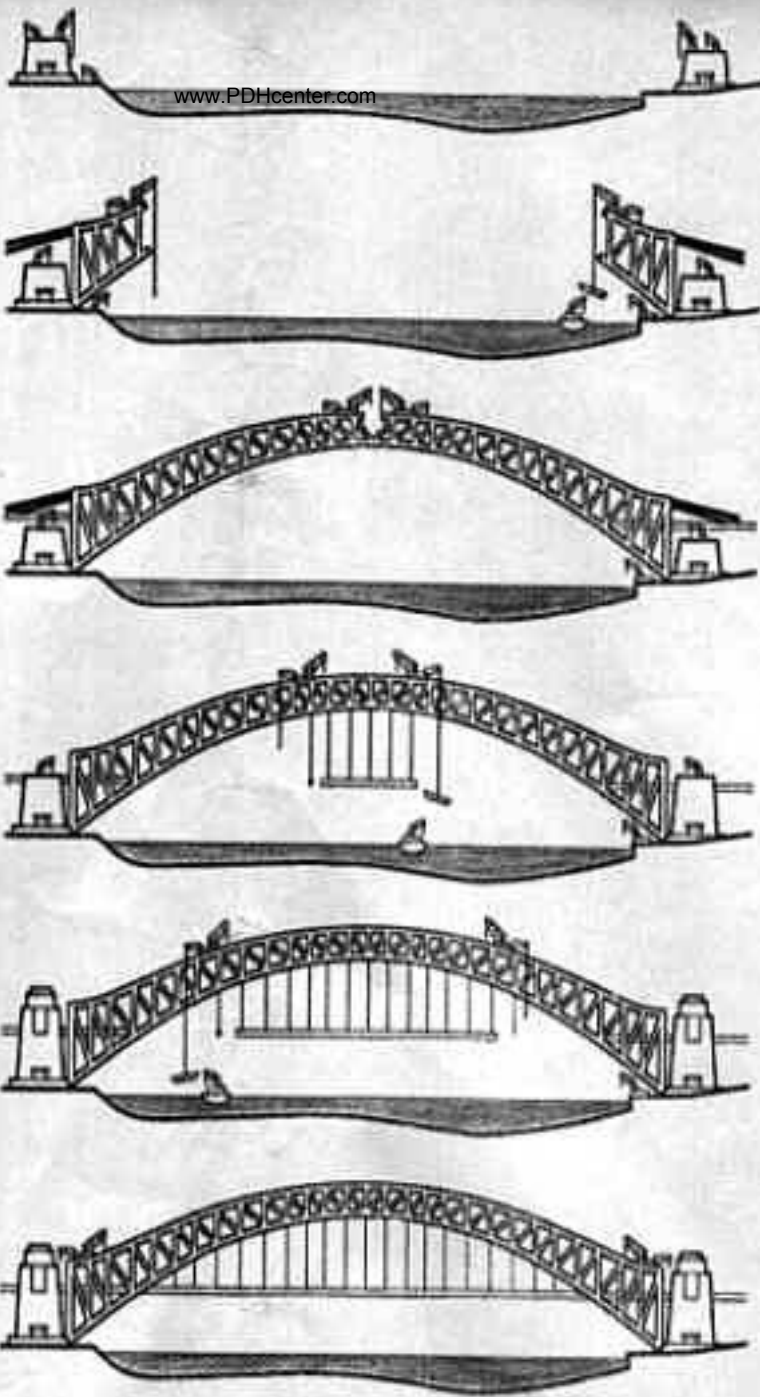

*“...The great arch once finished, the creeper cranes, which had met at the summit, reversed their progress, moving slowly down the slopes of the upper chord as they hoisted into place the long vertical hangers, weighing anything up to 35-tons each, by which the horizontal trackway was suspended from the arch...”*

*Wonders of World Engineering, 1938*



**September 1930: the Arch is complete (self-supporting)  
and ready for hanging of the deck to commence**





**First (mid-span) hanger being lifted (in cradle) by creeper crane to its permanent position.**

**Each hanger was attached at a *Panel Point* (where a vertical lattice truss-strut meets the bottom chord). Each hanger supports one side of a cross girder via a pin connection.**

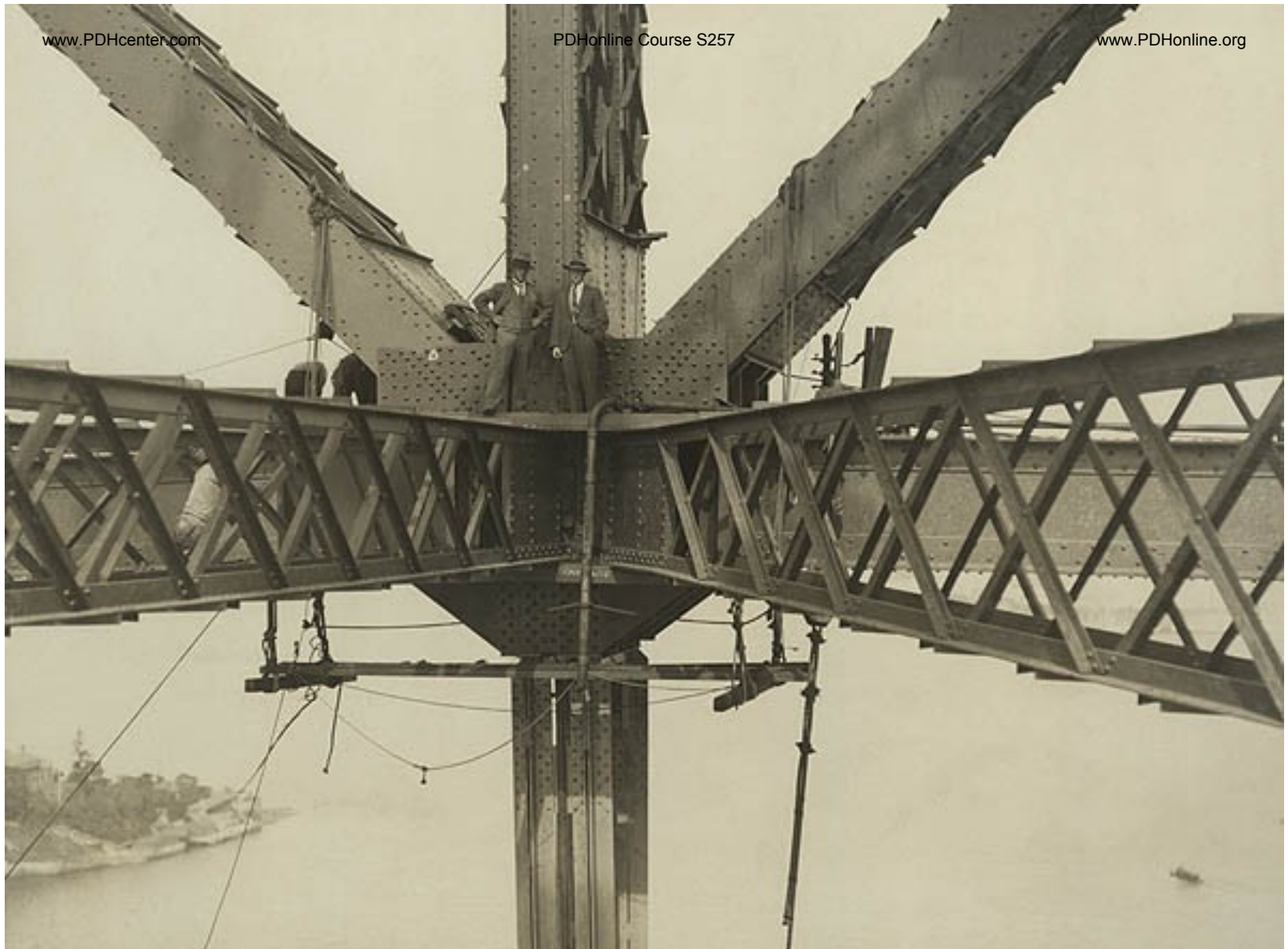

**Center hanger secured to panel point in lower chord** 328



*“Hangers for the deck ranged from 7.3 to 58.8 meters in length. A special cradle was needed to lift the hangers since they had to be hoisted into a position directly under the arch truss and, now that the arch was complete, the traveler crane could only lift steel sections beside the truss. The main crane lifted the hanger and cradle while a jigger crane rotated it into position from horizontal to vertical. A rigger rode up atop the hanger in order to bolt it to the underside of the bottom chord.”*

**RE: excerpt from: *Building the Sydney Harbour Bridge***



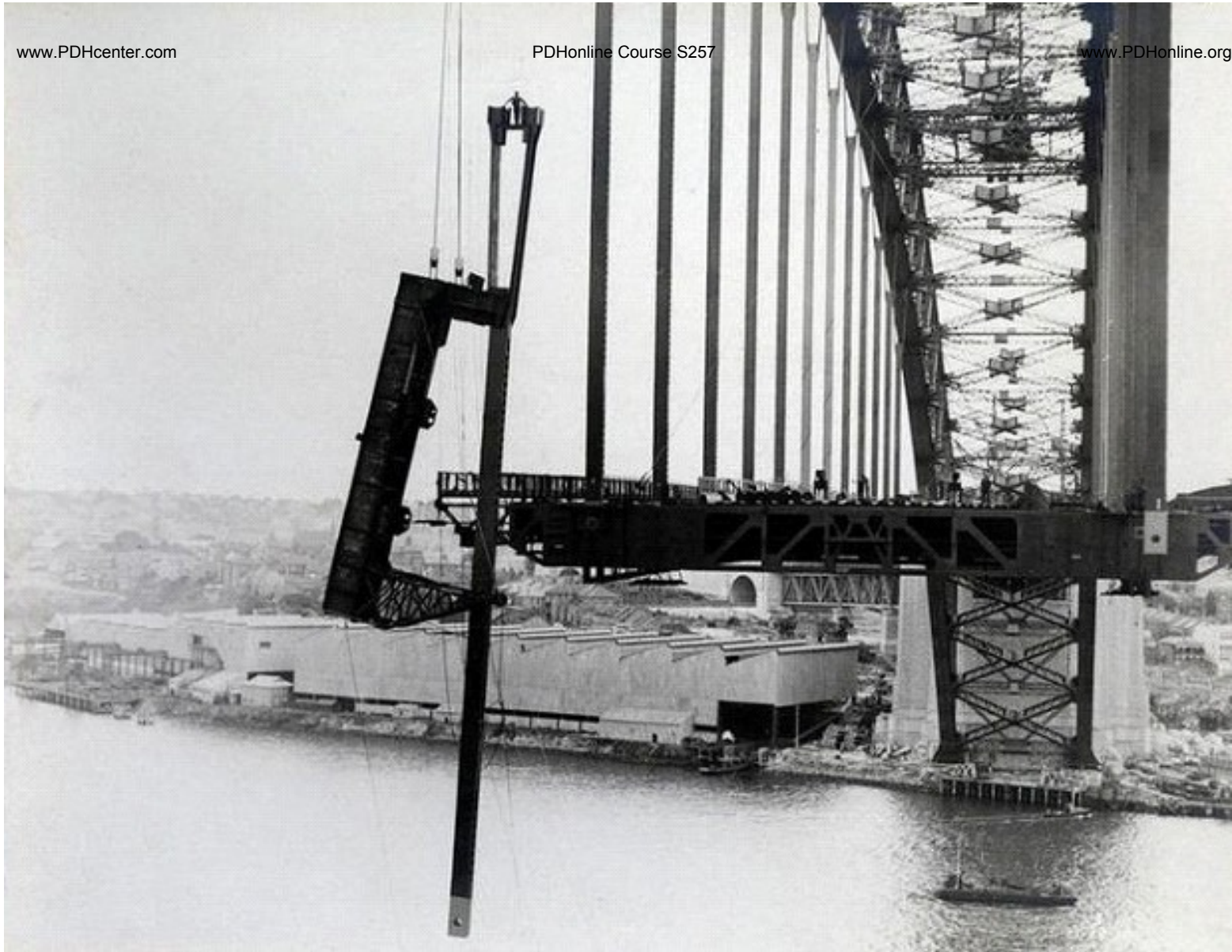

**Hanger being lifted in special cradle**





**First hanger being lifted (left) and secured in-place (right). Note the hole at the bottom of the hanger (for pin connection to one side of cross girder)**







*“Each pair of hangers supported a 48.7 meter long, 110-ton cross girder – the heaviest steel pieces to be lifted into place. A steel pin connected each hanger to the cross girder.”*

**RE: excerpt from: *Building the Sydney Harbour Bridge* <sup>333</sup>**



**Pair of hangers awaiting cross girder (left).  
Cross girders attached to pair of hangers (right)**



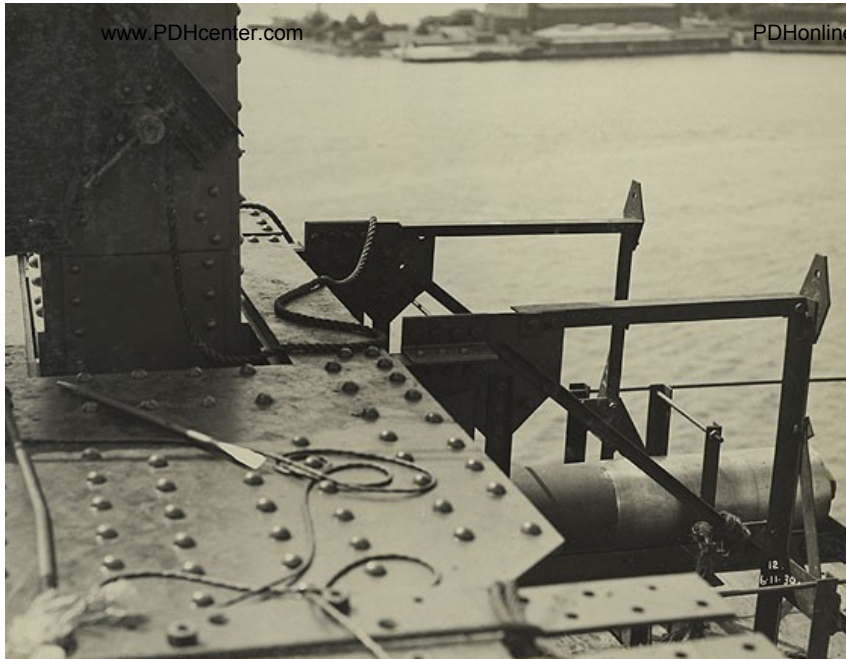

www.PDHcenter.com

PDHonline Course S257

www.PDHonline.org

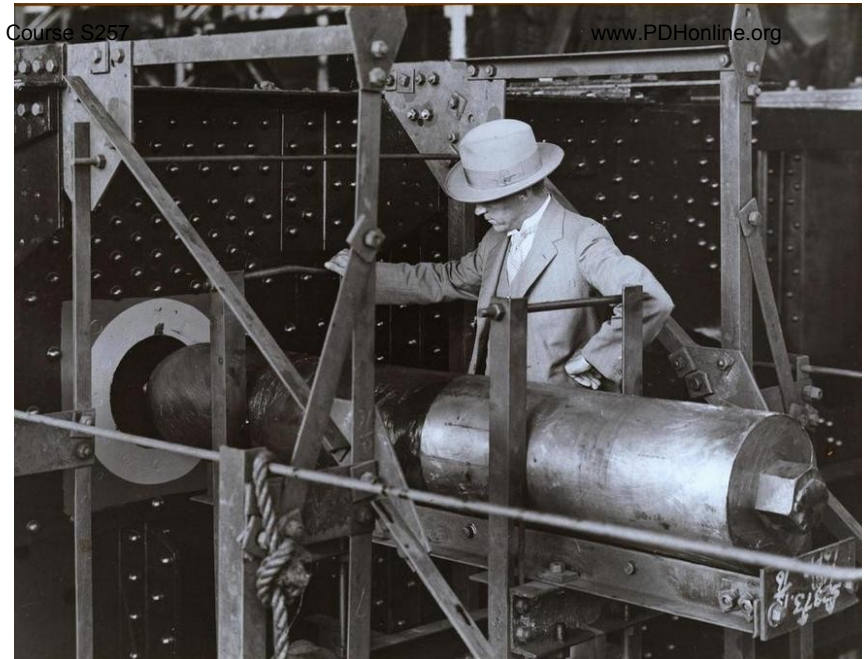

**Outrigger platform - for ramming  
pin into hanger-hole (upper left)  
14-inch diameter cross girder pin  
and pilot pin (upper right)  
14-inch pin secured to hanger and  
cross girder (lower left)**



**First pair of hangers supporting first cross girder**



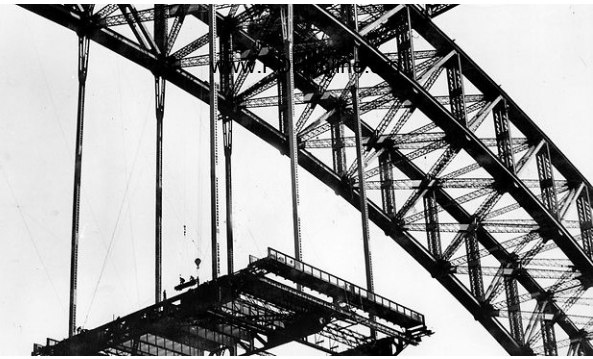
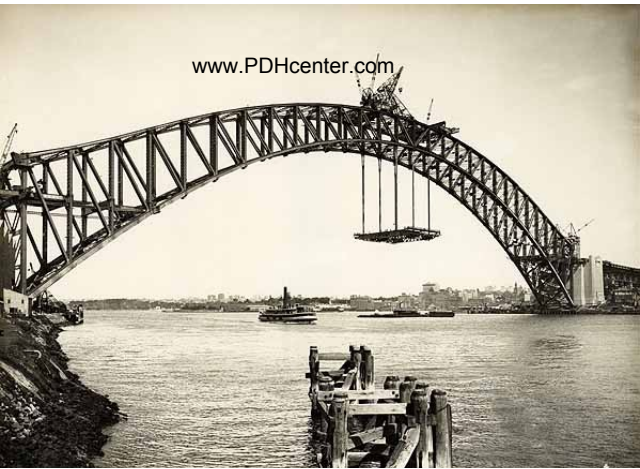





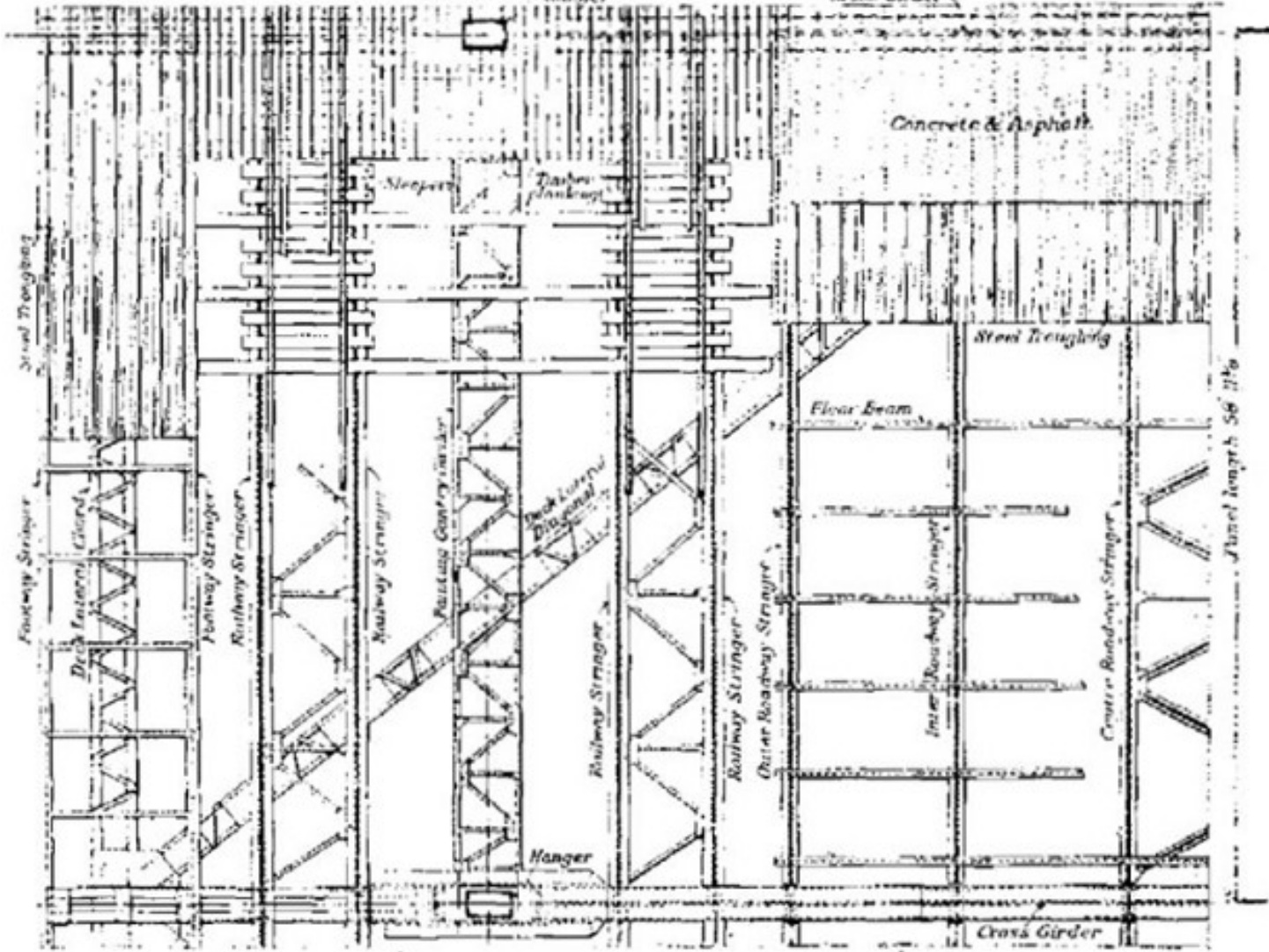

**Half-plan of one panel of deck**





## Steel Deck “Troughing”



## **Maintenance Gantry (traverses underside of deck between lower chord/s)**



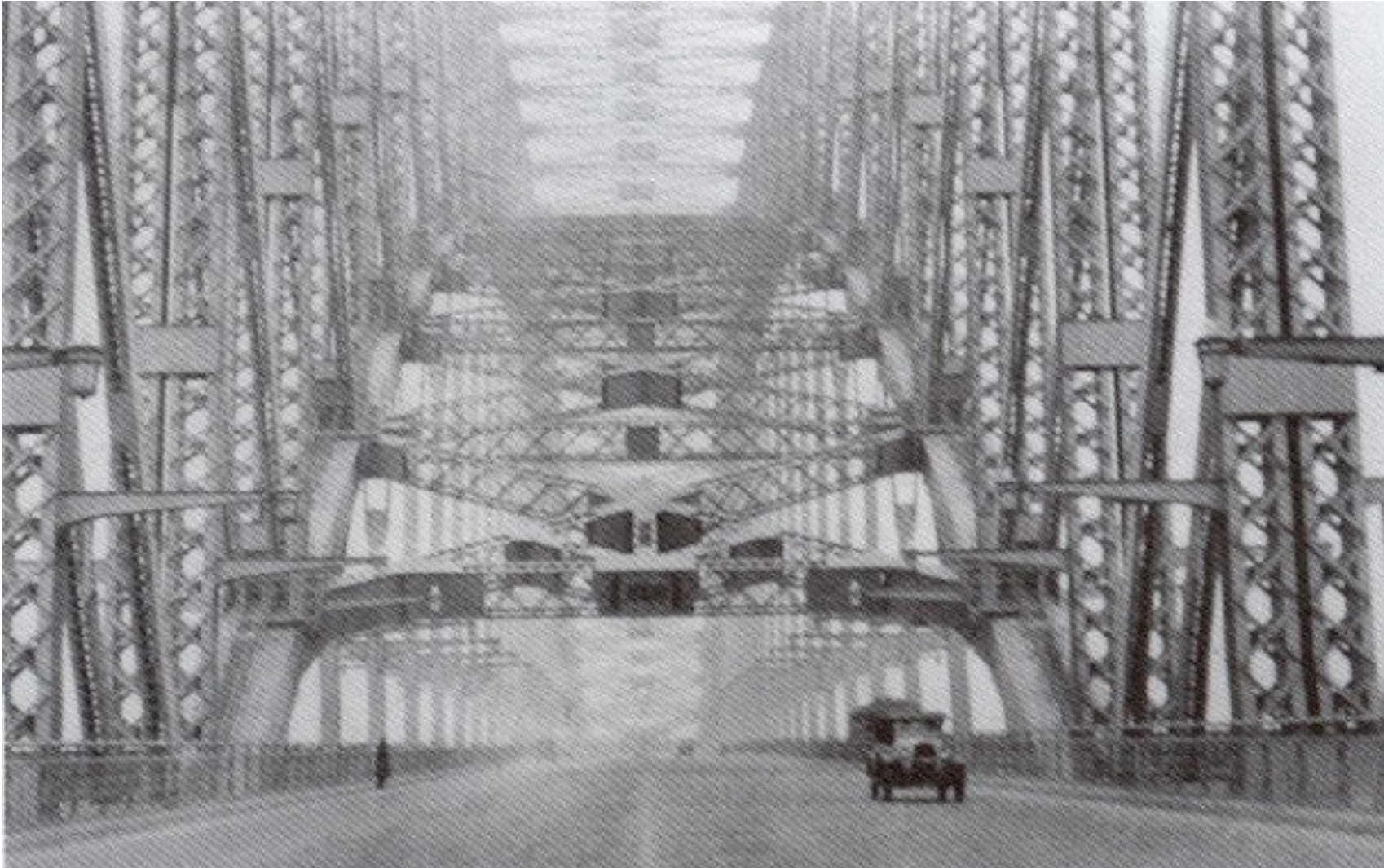

# PYLONS



www.PDHcenter.com

PDHonline Course S257



www.PDHonline.org

*“...Meanwhile, the wire cables, already slacked off so that no contraction through cold could cause any tendency to open up the central arch joints, were finally removed and shipped back to England. The creeper cranes were dismantled after they had finished their homeward journey and come to rest over the first panel of the arch. Finally, the pylons were completed to their full height of 285-feet, in the form of twin towers, each pierced for a footway and one railway track. The two inner railway tracks and the roadway run in the space between them...”*

*Wonders of World Engineering, 1938*





**Temporary framework (between Pylon towers)  
for support of two hoisting cranes (set atop)** 346



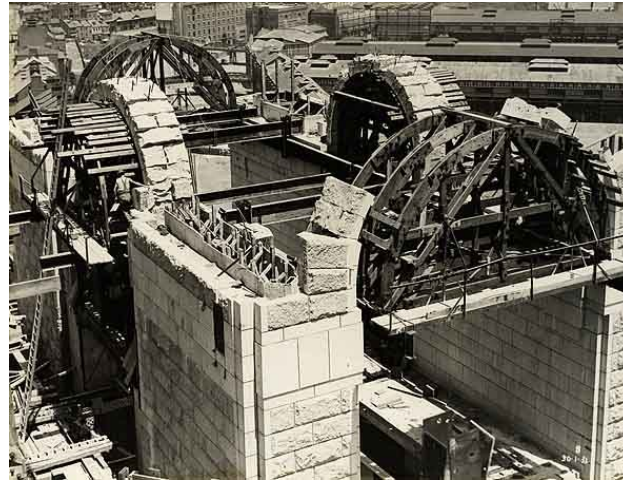
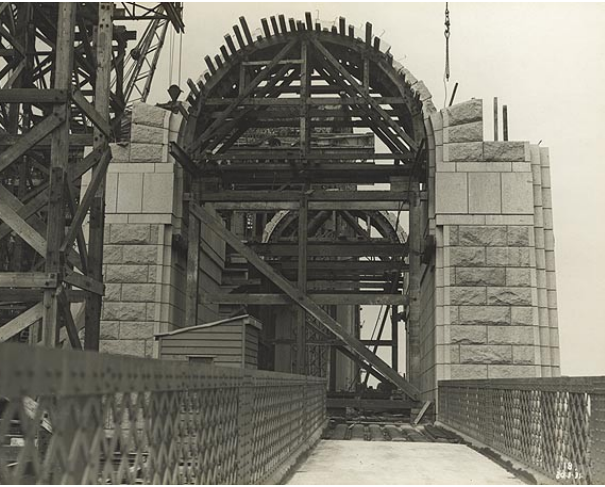

**Using wooden falsework to form the four arches of each Pylon tower (above)**

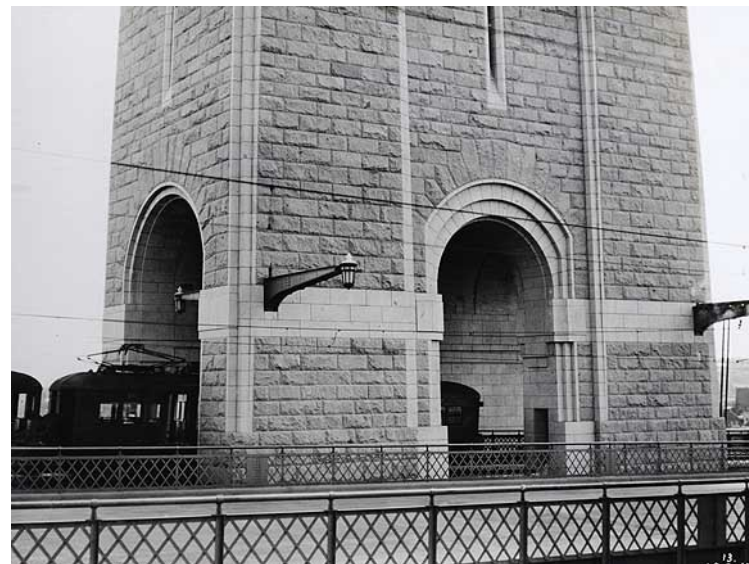
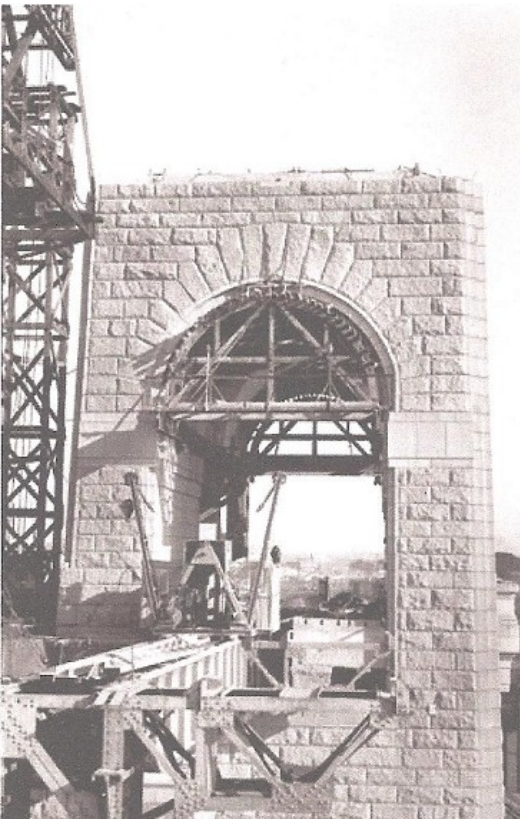

**Pylon tower arches complete (left)**





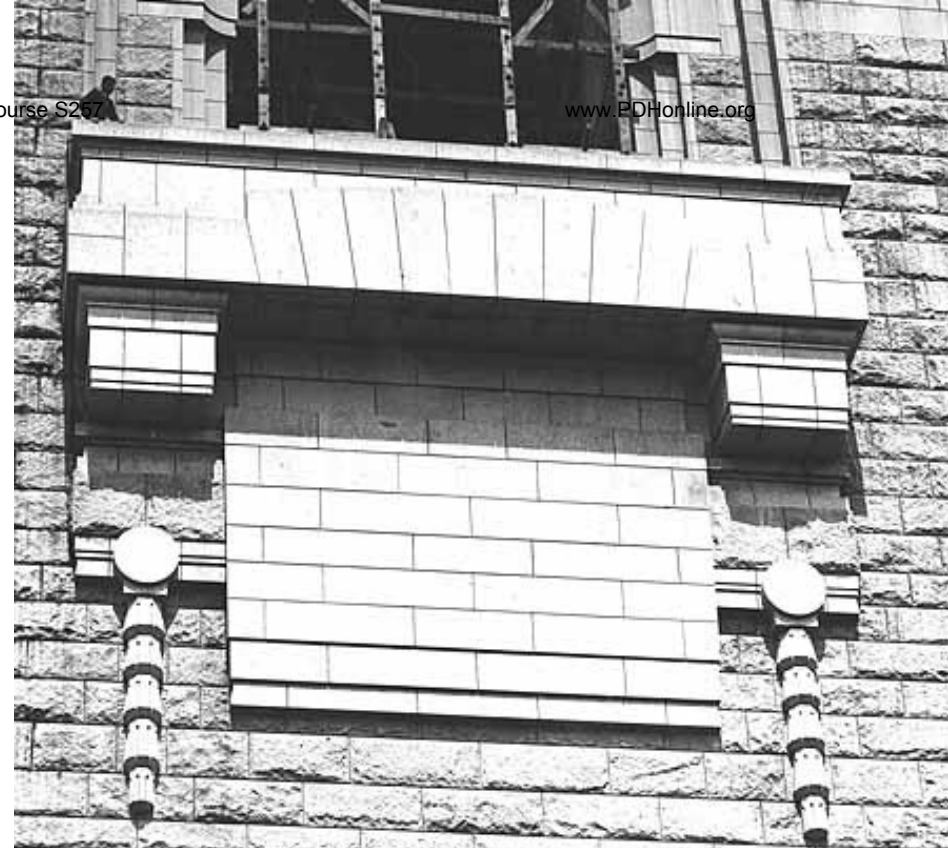
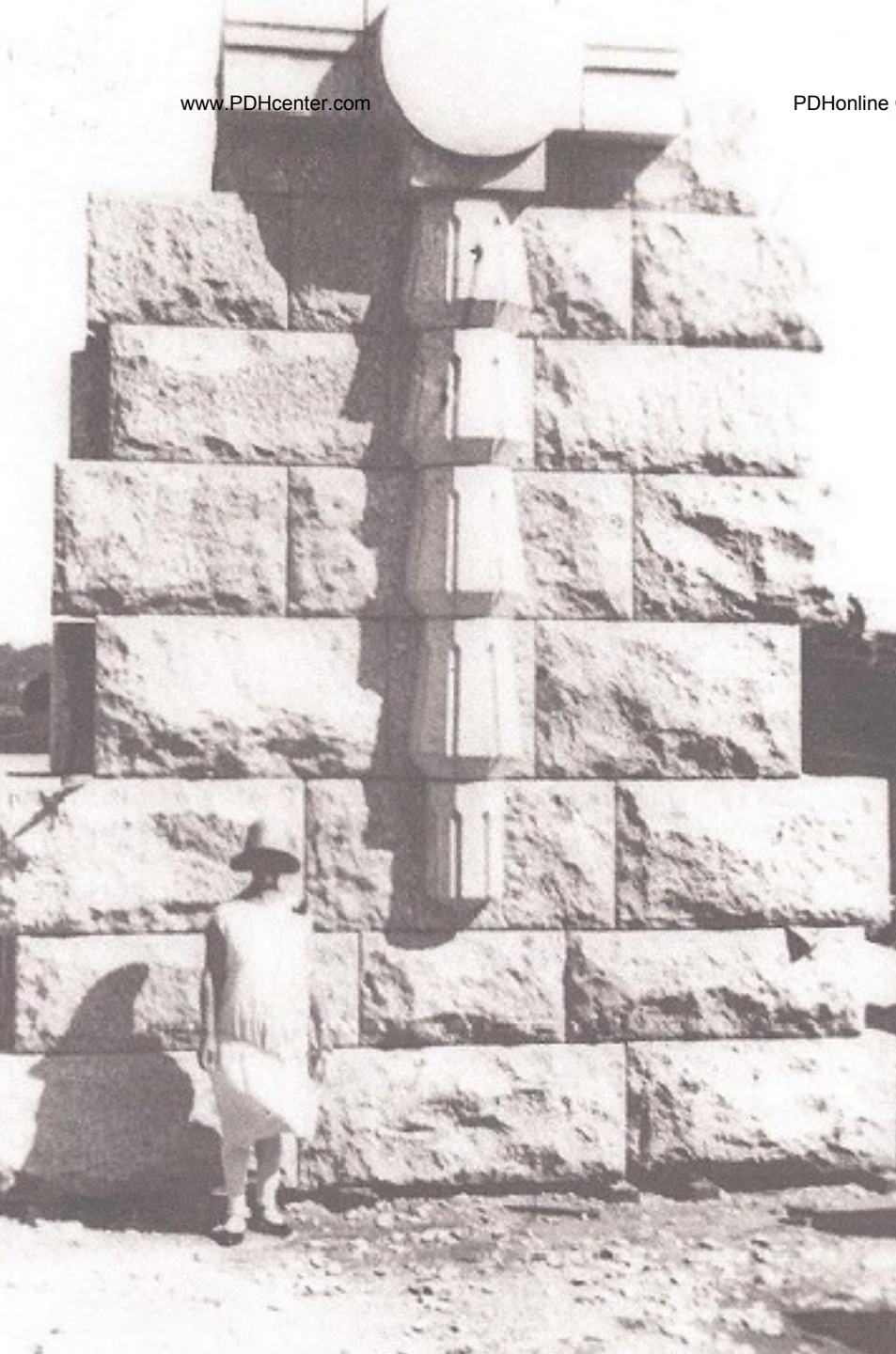

## **Granite Dressed Stones**

**In general, the masons' work was of such high quality that mortar for the joints was hardly necessary. This test assembly (left) awaits shipment to Sydney on the Moruya River dock.**



## **Setting of the last stone, February 1932**

**Stonemason foreman Jock Mackay lays the last block of granite on the NW Pylon. Looking on are JJC Bradfield, Lawrence Ennis, RJ Butler and James Muir. On February 6, 1932 (a week earlier) rigger foreman James Campbell (while dismantling a derrick crane) was knocked off the Pylon when a gust of wind caught the crane. The ceremony was held in the spot where he fell to his death to honor his memory and his faithful service.**



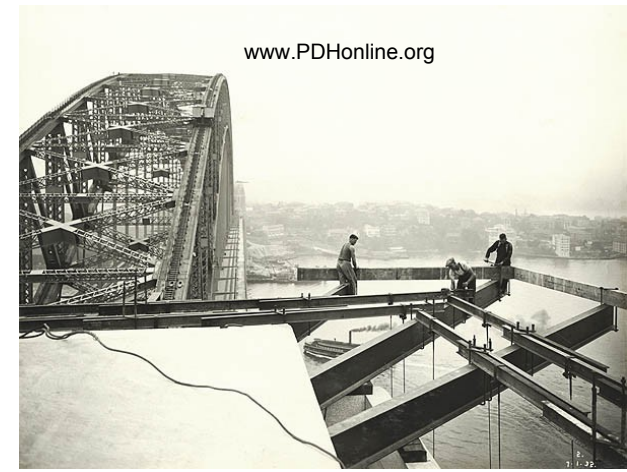

**Outriggers (for suspended scaffolding) atop Pylon (above)  
Day laborers “scrubbing down” - cleaning the granite  
face/s by hand from top to bottom (below)**

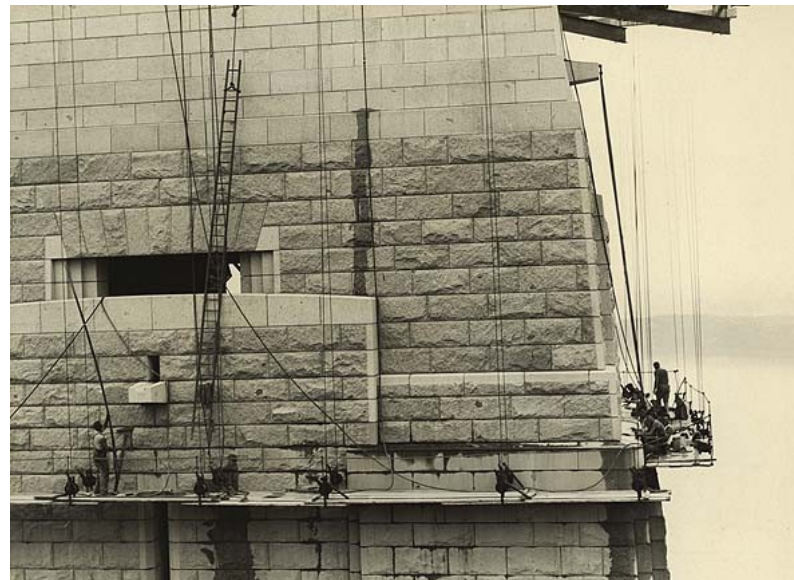



*“The work was hard. You were frightened of being put off if you didn’t pull your weight so you never even looked up – otherwise you were on the dole. We worked 11 and 12-hour days.*

**Pat Crawley – Day Laborer,  
February 1932**



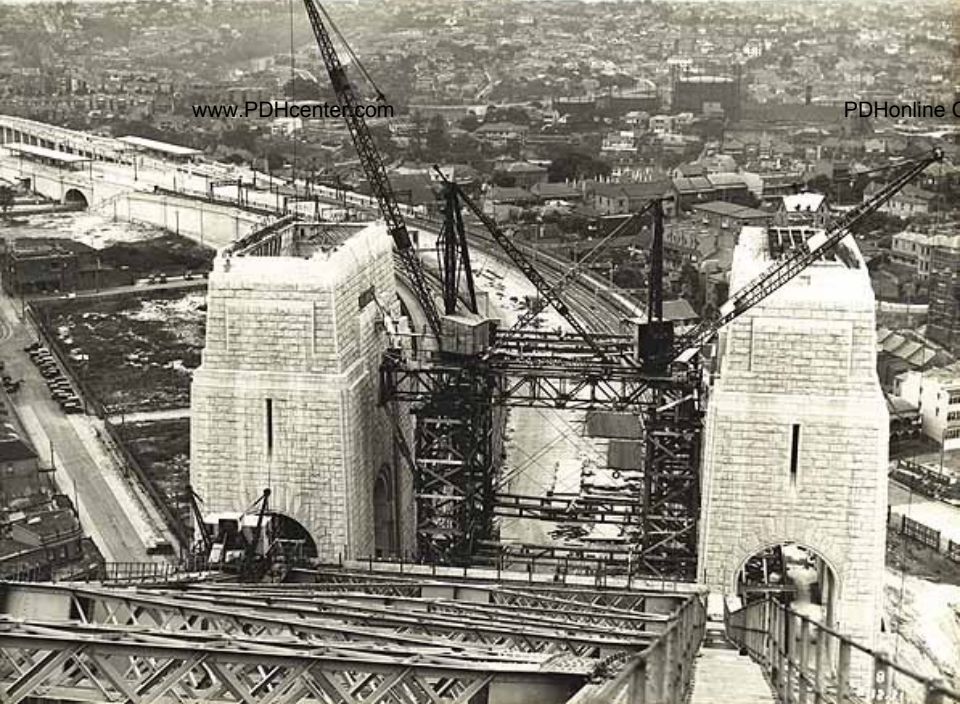

**N. Pylon (top left) and S. Pylon (top right) nearing completion**



**Train passing through Pylon arch (left)**





***“In tendering my thanks, I do not forget the workmen who so splendidly responded to the trust we placed in them...Every man gave something of himself to this bridge of steel and fire, built with the toil, the sweat and the guts of a thousand men”***

**JJC Bradfield – Chief Engineer, SHB and  
Lawrence Ennis – Director of Construction, SHB  
(respectively)<sup>354</sup>**



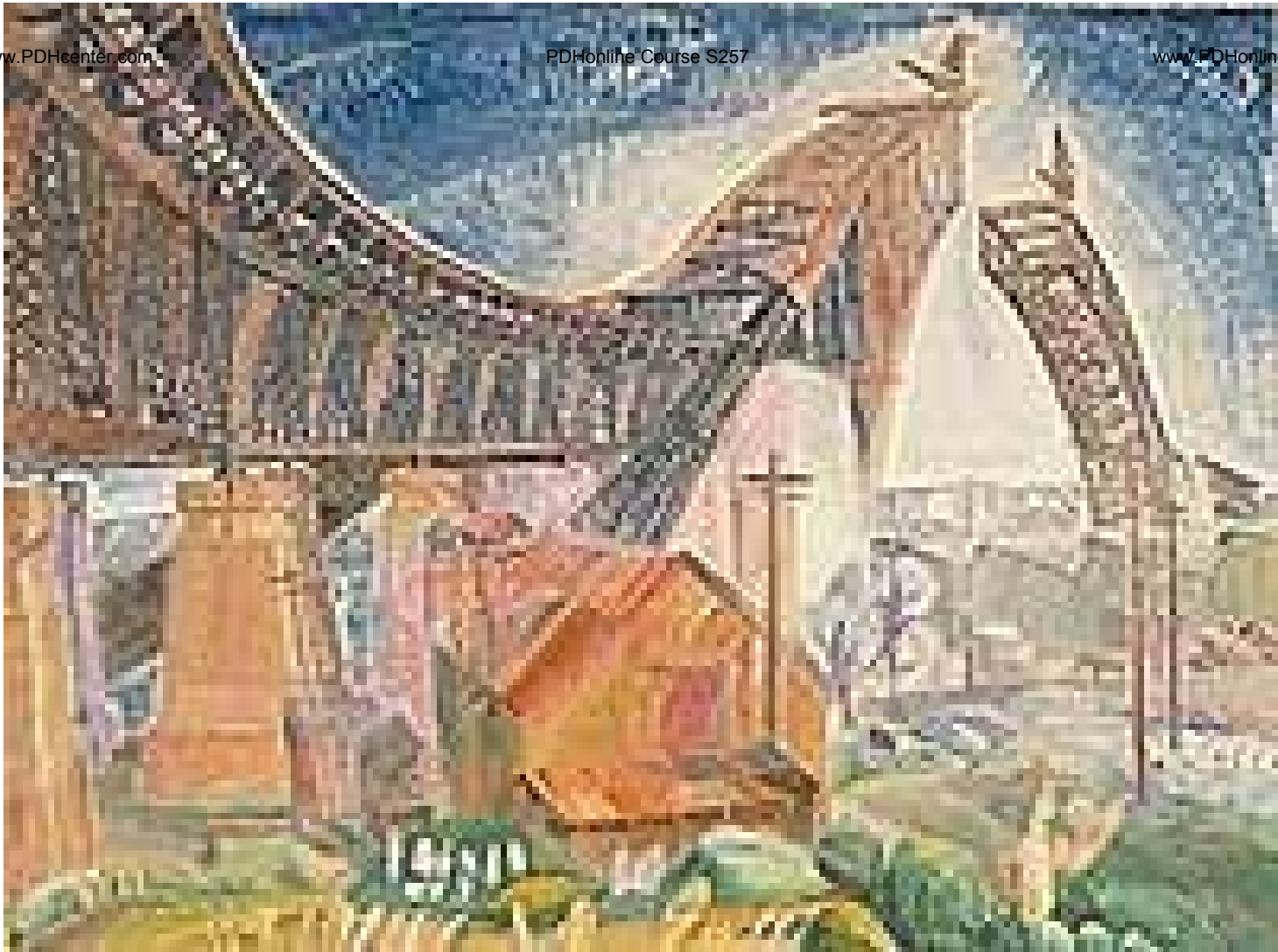

***The Bridge in Curve (1926)***  
**National Gallery of Victoria**  
**by Grace Corrington Smith**





# SYDNEY HARBOUR BRIDGE

THE BRIDGE WAS CONSTRUCTED FOR AND THE APPROACHES BY THE  
PUBLIC WORKS DEPARTMENT OF NEW SOUTH WALES

THE GENERAL DESIGN AND SPECIFICATION WERE PREPARED AND  
THE WHOLE SUPERVISED ON BEHALF OF THE GOVERNMENT OF NEW SOUTH WALES BY  
J.J.C. BRADFIELD, D.SC.(ENG.) M.E. M.INST.C.E. M.I.E.AUST. CHIEF ENGINEER

CONTRACTORS FOR THE DESIGN AND CONSTRUCTION OF THE MAIN STRUCTURE  
DORMAN, LONG AND CO LIMITED, MIDDLESBROUGH, ENGLAND

LAWRENCE LAVIS, O.B.E. DIRECTOR OF CONSTRUCTION FOR THE CONTRACTORS  
RALPH FREEMAN, M.INST.C.E. M.I.A.M.SOC.I.E.

CONSULTING AND DESIGNING ENGINEER FOR THE CONTRACTORS

SIR JOHN BURNET AND PARTNERS, ARCHITECTS FOR THE CONTRACTORS

THE HONOURABLE M.A. DAVIDSON, M.L.A.  
MINISTER FOR PUBLIC WORKS

G.W. MITCHELL,  
DIRECTOR OF PUBLIC WORKS



# PHOTO FINISH



***“J.J. Bradfield’s design comprised an arch of a dimension making it the largest single span structure in the world. Then the engineers of the Port Authority came into evidence with a design for a larger arch, and so Australia was beaten by a few feet in the race for the distinction of bridge building. However, if the Bayonne span is longer, the Sydney structure is larger. Against the 16,000 tons of steel used in joining Bayonne to Staten Island, 37,000 tons were required to complete the structure spanning the beautiful harbor at Sydney.”***

**D.M. Dow – United States Secretary for Australia, 1931**  
**RE: the friendly rivalry between the *Sydney Harbor Bridge* and Othmar Amman’s *Bayonne Bridge* (both steel-arch spans) built almost simultaneously and both greatly influenced by Gustav Lindenthal’s *Hell Gate Arch***



**Arch complete and deck being hung over the *Arthur Kill*  
(between Bayonne, NJ and Staten Island, NY)**



## **Bayonne Bridge (1931)**

**As a cost-saving measure (at the height of the depression), Othmar Amman and the *Port of New York Authority* decided to leave the steel support frame of the abutments exposed – to be completed at a later date when funds were available (it never happened). Bayonne Bridge is only a few inches longer than SHB.**



## **Othmar Amman (ca. 1963)**



# Part 7

# A Great Avenue



*“...The completion of a continuous thoroughfare, at rail level, between Dawes Point on the south side of the harbour, and Milsons Point on the north, took place on February 17, 1931. But much still remained to be done, and Sydney Harbour Bridge was not ready for its formal opening until more than a year later, on March 19, 1932...”*

*Wonders of World Engineering, 1938*



- During all of 1931, all types of finishing work proceeded;**
- \* concrete (over the troughing) & asphalt (bridge deck)**
  - \* installation of cross-harbor power & telephone lines**
  - \* installation of cross-harbor water, gas & drainage pipes**
  - \* laying of railway & tram tracks**
  - \* roadway improvements/additions etc.**

**January 12, 1932: Bridge contractor Dorman Long & Co. makes SHB available to the NSW government for testing**

**March 15, 1932: Dorman, Long & Co. officially turn over SHB to the government of NSW**

**March 16, 1932: Three days prior to the official opening, 52K school children from schools throughout NSW are allowed to march across the bridge. A “Message of Goodwill and Congratulations” is presented by the school captains of Fort Street Boys and Girls High School/s at the opening ceremonies on March 19<sup>th</sup>.**



**March 19, 1932: Premier of NSW – Mr. Jack Lang, decides to preside over the official opening ceremonies for the Sydney Harbor Bridge. A similar ceremony was held at the north end of the bridge presided over by Alderman Primrose – Mayor of North Sydney. The festivities included a relay of 550 km across Australia culminating in the delivering of a message of good will from the nation’s school children, an air force fly-by and a 21-gun salute. A two-kilometer long “Bridge Parade” traversed the bridge led by the “Youth Australia League” band. It was followed by 656 school children, 100 SHB workers, 25 Aborigines, representative groups (i.e. WWI veterans), marching bands and 27 floats (some horse-drawn, others motorized). The opening ceremonies marked the beginning of two weeks of celebratory festivities throughout Sydney.**



**Stonemason foreman Jock MacKay leads one-hundred fellow bridge workers at the outset of the *Bridge Parade***

**The parade would last eight-hours, to mark the victory of the masons' union in achieving an eight-hour work day (rather than the sixty-hour week previous to SHB)**

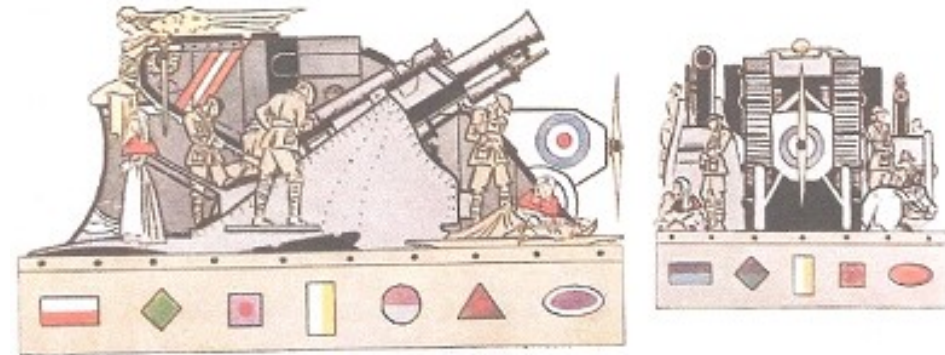
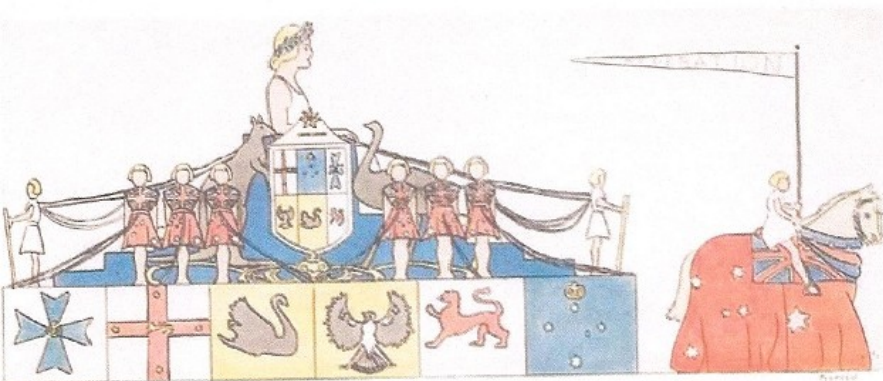
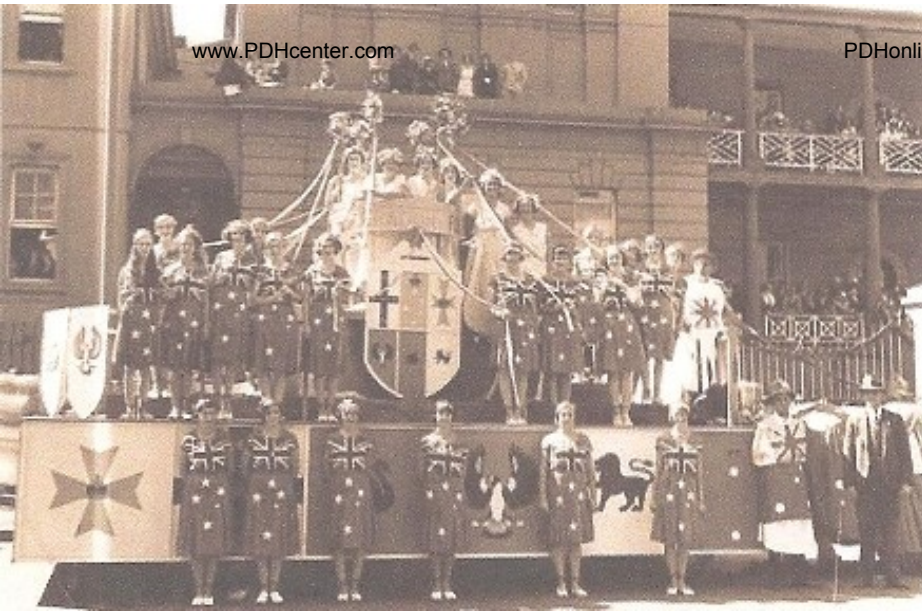

***The Federation Float (left) and The Great War Float (right)  
(Bridge Parade)***







**After a message of congratulations was offered by the King, Sir Phillip Game – Governor of NSW (left), made a speech followed by the NSW Minister for Public Works, a director of Dorman, Long & Co. and finally by Lawrence Ennis – SHB Director of Construction**

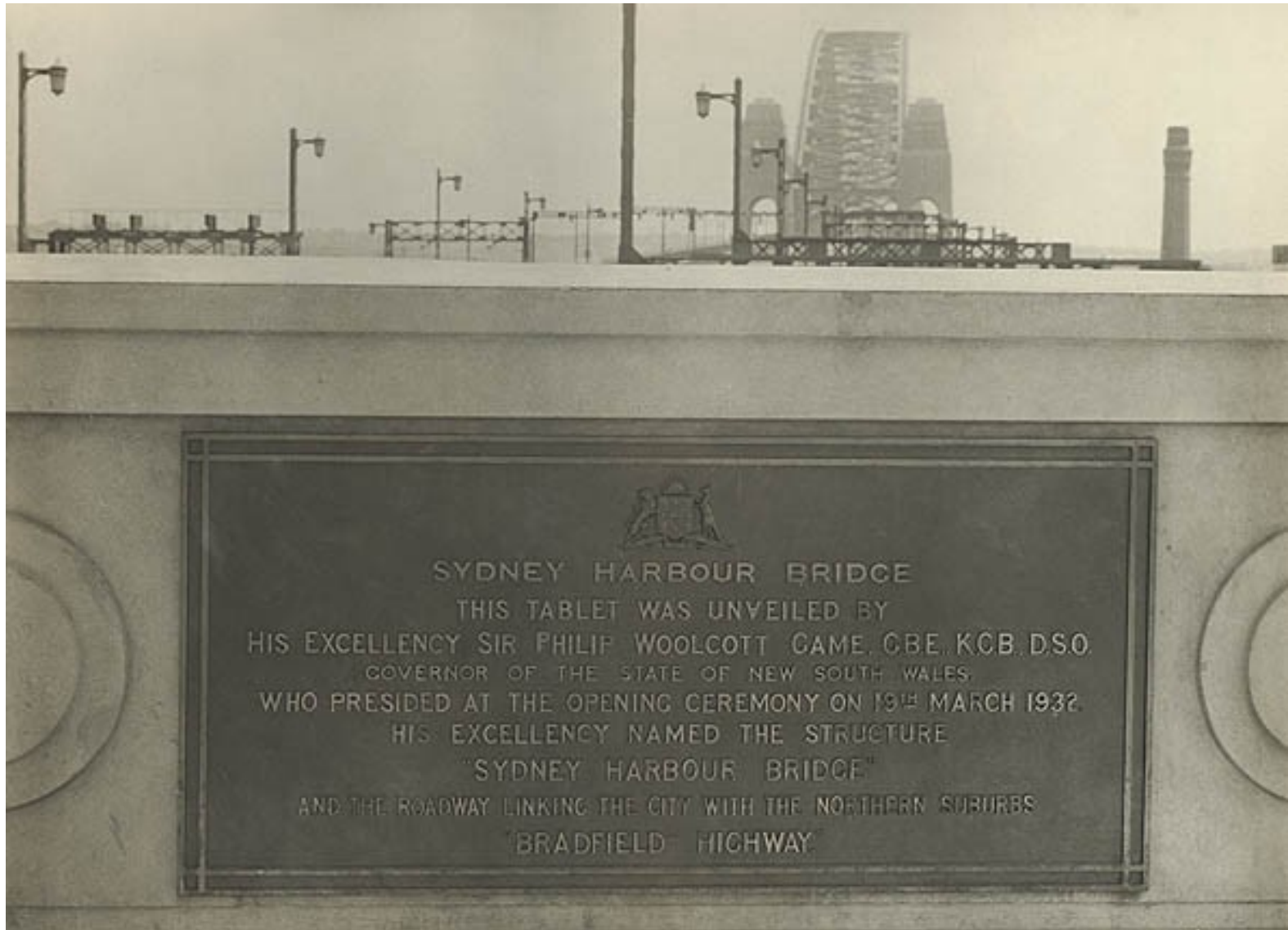



*The Bradfield Highway*  
(a.k.a. Sydney Harbor Bridge)

***“I open this bridge in the name of his Majesty the King and all all the decent citizens of New South Wales”***

**Captain Francis Edward DeGroot (1888-1969)**

**RE: proclamation he made at the opening day ceremony. Mounted on horseback, he slashed the ribbon with his sword before Premier Lang could officially cut it. DeGroot and his wife were Irish immigrants to Australia in 1920. He established a successful antiques business in Sydney and served with distinction on the western front during WWI. He was a member of (like Alderman Primrose Mayor of North Sydney) *The New Guard* – a right-wing, semi-fascist paramilitary group. He resented the fact that the King nor any member of the royal family were invited nor asked to cut the ceremonial ribbon thus officially opening the bridge.**





**Captain DeGroot had joined the rear of a cavalry troop participating in the opening day ceremonies. He charged forward to cut the ribbon before Premier Lang could. He was arrested at the scene and fined five pounds for damaging public property.**

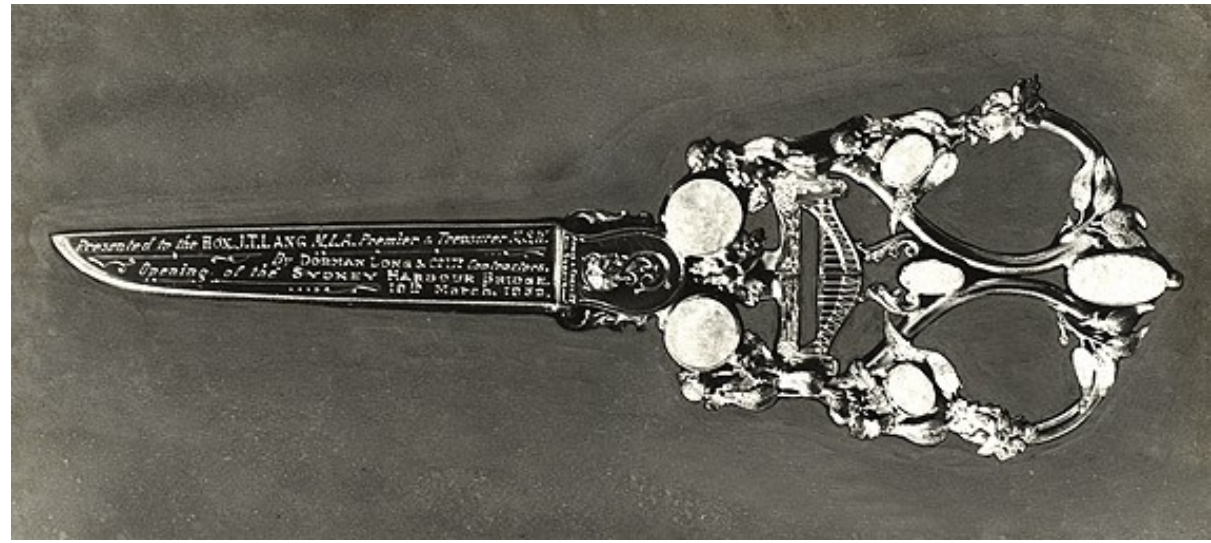

**After the DeGroot incident, the ribbon was retied and Premier Lang officially opened the Sydney Harbor Bridge by cutting the ribbon with a pair of ceremonial scissors**



***“Today is the day of days, when political differences are forgotten. New South Wales unites in the glorification of our Bridge, an added attraction of our harbour...”***  
***Labor Daily – March 19, 1932***

Everybody's  
Singing it !

# THE BRIDGE WE'VE BEEN WAITING FOR



Words and Music by Jack Lumsdaine

Featured on



No. G21235

Price : **2/-**

D. Davis & Co. Ltd.  
SYDNEY.

Copyright.

Obtainable on Masterouch Rolls



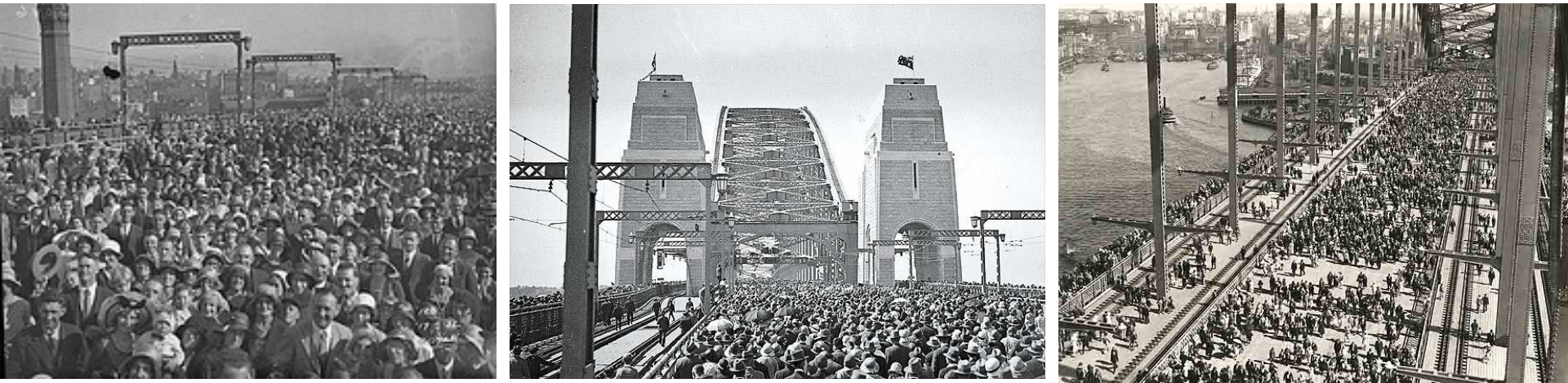

**For just one day at least, Sydneysiders could forget their troubles (the depression was near its height in early 1932) with a celebration of the opening of SHB for which they had waited eight years. It was estimated that 750K people from Sydney and around all Australia were in attendance; along the shoreline, on the bridge and in the harbor to participate in the celebrations.**



# Harbor Festivities

## March 19, 1932

*“The Sydney Harbor Bridge, so long a dream, is to-day a bold and a practical reality. A triumphant arch of steel, humanising our landscape in the ideals of all true Australians, simplicity, beauty and service. It was a big plan; the thoughts of many men. Its success lies in the loyalty of Engineers and workmen to the Ideal of a Big Plan. Inch by inch, step by step, they built the bridge, until to-day it is finished, a work of service, a thing of beauty, which will assert itself long after we are gone”*

**JJC Bradfield – Chief Engineer, SHB**







***“...The city of Sydney could already claim to have the finest harbour in the world. With the completion of the bridge her inhabitants obtained the world’s largest arched bridge. The magnificence of Australia’s finest bridge is such as to make an indelible impression on any one seeing it for the first time.”  
Wonders of World Engineering,  
1938***

**Build it and They Will Come**



## SHB (ca. 1932)



## **SHB (ca. 1940)**





## SHB (ca. 1959)



**The four original (wide) center lanes were reconfigured to accommodate six traffic lanes. In 1958, tram service across SHB was eliminated and two additional road lanes were added (lanes 7 & 8).**

**Interestingly, the *Bradfield Highway* (SHB) is designated as a *Traveling Stock Route*. This designation allows livestock to be herded across the bridge between midnight and sunrise (with notice given). Fortunately, given the high-flow of traffic, it has been several decades since the bridge was used for this purpose.**



**By the 1980s, it was apparent that SHB was overburdened by its traffic load and relief was needed. In 1988, work began on the *Sydney Harbour Tunnel*. SHT opened for motor vehicle use only on August 29, 1992.**

# Legacy







SYDNEY BRIDGE  
On nearing completion, will rank  
as one of the greatest engineering  
achievements of the present day.

THE greatest satisfaction in life is to realise that one's job has been well and truly done. PDHonline Course S257

The value of any achievement is enhanced by the toils and trials of the way.

It is a monument to the skill and energy, patience and determination of those who have carried it through from its first inception as an idea to its completion, showing to the world what inspired endeavour can do.

One has but to study the career of such a Company as the Standard to realise what degree of excellence can be not only aimed at, but achieved.

The work of British engineers, in whatever sphere, is acknowledged supreme, every continent and country carries examples of work brilliantly designed and carried out.

The Standard car is an outstanding example of wise forethought, efficient workmanship, thorough inspection and test.

Standard cars are the best value—prove this for yourself.

# All-British Standard

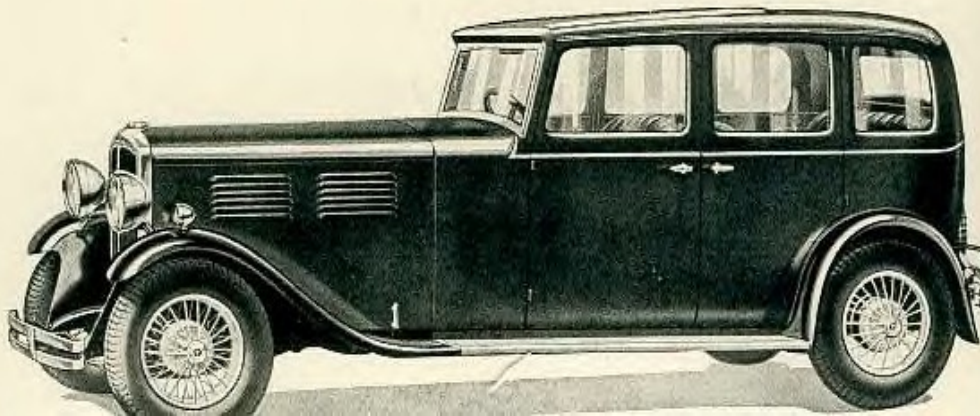

## TWO Great Australian ACHIEVEMENTS

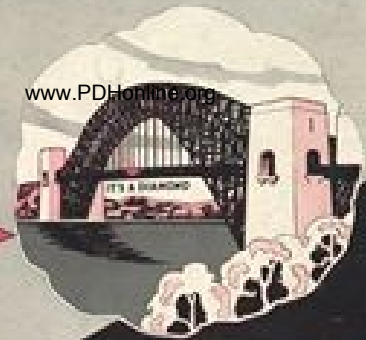

**RADIO BATTERIES**  
AND TUBE REFILLS



... and both built to last!

## PROGRESS—the Age of Concrete



GREAT WORKS CONSTRUCTION DEMAND A  
TRUSTWORTHY QUALITY PORTLAND CEMENT

### In this March of Progress KANDOS CEMENT is Playing an Important Part

The value of the Kados Cement is attested  
by the fact that it is used in the  
construction of the Sydney Harbour Bridge

KADOS CEMENT 40 LBS  
NET WEIGHT  
KANDOS CEMENT CO. LTD.  
SYDNEY, AUSTRALIA













