



**PDHonline Course C616 (2 PDH)**

---

# **An Introduction to Water Supply, Treatment and Storage in Cold Regions**

*Instructor: J. Paul Guyer, P.E., R.A., Fellow ASCE, Fellow AEI*

**2020**

**PDH Online | PDH Center**

5272 Meadow Estates Drive  
Fairfax, VA 22030-6658  
Phone: 703-988-0088  
[www.PDHonline.com](http://www.PDHonline.com)

An Approved Continuing Education Provider

# An Introduction to Water Supply, Treatment and Storage in Cold Regions

*J. Paul Guyer, P.E., R.A., Fellow ASCE, Fellow AEI*

## CONTENTS

1. GENERAL
2. PLANNING UTILITY SYSTEMS
3. WATER SOURCE DEVELOPMENT
4. WATER TREATMENT
5. WATER STORAGE

This course is adapted from the *Unified Facilities Criteria* of the United States government, which is in the public domain, is authorized for unlimited distribution, and is not copyrighted.

The Figures, Tables and Symbols in this document are in some cases a little difficult to read, but they are the best available. **DO NOT PURCHASE THIS COURSE IF THE FIGURES, TABLES AND SYMBOLS ARE NOT ACCEPTABLE TO YOU.**

## **1. GENERAL**

**1.1 PURPOSE.** The purpose of this publication is to provide criteria and guidance for design of water supply, treatment and storage systems for facilities in arctic and subarctic regions. Only design criteria unique to cold regions (the Arctic and Subarctic) are provided. Where conventional practice is acceptable, refer to the professional literature.

**1.2 SCOPE.** Topics covered in this publication include water supply, treatment and storage.

**1.3 REFERENCES.** This publication deals only with special considerations for facilities in Arctic and Subarctic regions. References in the professional literature must be consulted in concert with application of this publication.

**1.4 ENVIRONMENTAL CONDITIONS IN THE ARCTIC AND SUBARCTIC.** The design, construction and maintenance of utility systems are all affected by the special environmental conditions found in the Arctic and Subarctic. These conditions include adverse temperatures, wind, and snow; high costs; remoteness of locations, limited availability of construction materials and labor; need for fuel additives, synthetic lubricants, oils and greases for construction equipment; thermal stresses; frost heaving and permafrost.

**1.4.1 TEMPERATURE.** The low temperature prevailing in the cold regions is the most critical environmental factor. The intensity of the cold is important, but equally critical is the duration of the cold period. Mean annual air temperatures in the Northern Hemisphere are presented in professional and government publications. Air temperatures in arctic locations range from highs of 80 degrees F in summer to lows of -75 degrees F in winter. Interior locations away from the tempering effects of oceans or large water bodies tend to have the greatest extremes. Sub-zero temperatures can

persist for months and it is not uncommon for air temperatures to remain below – 30 degrees F for a week or more at many locations in Alaska.

**1.4.2 PERMAFROST.** Permafrost is defined as any perennially frozen ground. The presence of frozen soil has the greatest impact on design and construction, so permafrost is typically a major design consideration. In the zone of continuous permafrost, frozen ground is absent only at a few widely scattered locations such as at the bottoms of lakes and rivers. In the discontinuous zone, permafrost is found intermittently.

**1.4.3 WIND AND RELATED FACTORS.** Mean annual wind speeds for most arctic and subarctic locations are usually about 5 to 10 miles per hour in the interior and 10 to 20 mph at coastal locations. The combination of wind and low temperatures results in very large heat losses from exposed facilities and presents hazards for personnel. Blowing and drifting snow can create major construction and operational problems even when the total precipitation is low. The location and layout of utility systems and access points for operation and maintenance must be given careful consideration during planning and design to avoid problems with drifting snow.

## 2. PLANNING UTILITY SYSTEMS

**2.1 GENERAL CONSIDERATIONS.** In the Arctic and Subarctic, utility systems are usually the most costly component in construction of installations. The layout of a new installation is often controlled by the type of distribution and collection systems selected for the utilities network. As a result, planning for a new installation in the cold regions must include consideration of utilities at a very early stage to ensure overall cost effectiveness.

**2.1.1 USEFUL LIFE.** The useful life for utility systems and equipment in cold regions is shorter than for the same units operated in more temperate climates. Items of equipment that must operate throughout the winter are particularly critical. Trucks used for water delivery or waste collection are examples. Table 2-1 presents typical useful lives for some utilities components in the Arctic and Subarctic.

Component	Useful life (years)
Wells	30
Pumps and controls	5
Storage tanks	40
Water distribution lines	40
Meters	10
Valves	10
Sewage collection lines	30
Lift station (not pumps)	30
Buildings	30
Paint (exterior)	10
Service connections	10-15
Trucks	4
Tracked vehicles	2-3
Backhoe (occasional use)	6-10
Compressor	5

Table 2-1

Approximate useful life of utility system components in cold regions

**2.1.2 CONSTRUCTION METHODS.** The three basic construction techniques used are modular, stick built, and prefabricated. The method selected must depend on site conditions and transportation facilities available. Modular construction, where the entire facility or a major component is preassembled and shipped via barge to the point of use, has been widely used at oil field developments on the northern coast of Alaska. It is advantageous in these locations since large barges can be used, the construction season is short, and labor is very expensive. Barges can usually begin to arrive in Barrow, Alaska, and the Eastern Arctic around the first of September. This means that non-modular construction materials must be shipped a year in advance and stockpiled for the next construction season. The stick-built approach, where all fabrication is done on site, and the prefabrication approach, where some components are preassembled at the point of manufacture, are more common at interior locations where transport is limited to air or small rivers. Prefabrication of insulating piping units has been shown to be cost effective for remote locations. The normal construction season varies from two or three months along Alaska's Arctic Coast to six or eight months in southern areas of Alaska.

**2.2 INSTALLATION LAYOUT.** The arrangement of buildings and other facilities at installations must be as compact as possible to reduce utility construction and operation and maintenance (O&M) costs. Unserviced areas and large open spaces such as storage yards, parks and playgrounds must be located on the outskirts of the installation. If possible, buildings must be located so as not to "shade" smaller structures from either sun or wind. Improper location of large buildings results in excessive snow drifting and burial of smaller structures. Doors and entry-ways to buildings must not be on the windward or leeward sides if possible to avoid drift interference. Orientation of the structure with the long axis parallel to the prevailing wind direction will reduce drifting problems. Roads and walkways will be constructed slightly above the general ground surface to avoid drifting problems, and construction in cut sections will be avoided if possible. Access points (manholes, service boxes, etc.) for utility system maintenance must be located so that entry can be guaranteed during the winter months.

**2.2.1 UTILITY NETWORKS.** The truck delivery of water and collection of wastes is still used at many communities in Alaska, Canada and Greenland. However, at most U.S. installations in the Arctic and Subarctic it will be more cost effective to provide piped systems for water supply and wastewater collection. The capital costs for piped systems are higher than for the truck delivery but operation and maintenance costs are significantly lower. The critical planning decisions for utility networks are (1) whether the pipes should be above or below and (2) whether the pipes should be installed as individual units or combined with other utility services in a utilidor. Above-ground utilidor systems offer easier access for maintenance and repair, and are cheaper to build where site conditions are poor. However, there are disadvantages. Above-ground units are exposed to extreme winter conditions and must have additional thermal protection as compared to a buried system. Above-ground systems are susceptible to vandalism and traffic damage, they disrupt pedestrian and vehicle traffic patterns, and create snow removal problems. In general, below-ground installation will be adopted wherever possible. In the Subarctic, an unfrozen zone may exist between the maximum seasonal frost penetration and the top of the permafrost. This condition can also exist in the Arctic near lakes and rivers, and on slopes with southern exposure. Pipes buried in permafrost or in the seasonal frost zone must not only be protected from freezing but must also resist the structural effects of heaving in the seasonal frost zone or thawing of permafrost. The terrain is relatively flat in much of the Arctic, and maintenance of the necessary grades for gravity sewers in either the aboveground or buried mode is difficult. Small pump stations, or pressure or vacuum sewer systems must be used to overcome these constraints.

**2.2.2 NETWORK LAYOUT.** A compact installation layout will make a central heating plant practical. This will reduce costs and energy consumption and also reduce the risk of fire. Service lines from utility mains to individual buildings are the main source of freezing problems. Buildings will be as close to the mains as possible with service lines 60 feet or less in length. It is typical practice in temperate climates to bury most utility lines in the streets. However, there are thermal disadvantages to this practice in cold regions since clearing the roads of snow will allow greater frost penetration. Burying

water and sewer mains in the front or back yards of dwellings, and in open areas where snow will not be removed, will maintain warmer ground and pipe temperatures.

Installation layouts should not be designed with dead-end streets. Dead-ends are difficult and expensive to service with circulating water systems and snow removal is more difficult. The largest consumers of water will be located at the extremities of the distribution system, if possible.

**2.3 EQUIPMENT.** For remote arctic installations the initial cost of most utility equipment is not as important as its reliability. A large inventory of critical spare parts is recommended and standardization of equipment to reduce the parts inventory will prove economical. Standby units for critical equipment are essential and are particularly important for emergency power and for heating systems. Humidity is a critical factor in enclosed spaces and both high and low extremes can be experienced in arctic situations. Since natural humidity is extremely low due to the low winter temperatures, humidifiers (to maintain humidity at about 30 percent) may be desirable in personnel spaces. Very high humidity is experienced in pump stations and enclosed treatment works, and thus condensation may occur on cold surfaces causing damage and inconvenience.

**2.4 REVEGETATION.** Areas excavated and backfilled for utility systems must be revegetated to prevent erosion. A revegetation procedure is summarized in table 2-2 for tundra areas. These grasses will die out in four to five years but the natural vegetation will have developed by that time. The initial seeding and fertilization will take place after the ice breaks up on local streams but before mid-summer. As indicated in table 2-2, a nitrogen-phosphorus-potassium (N, P, K) fertilizer will be applied with the initial seeding and then supplemental nitrogen at the beginning of the second growing season.



<b>Grass seed type</b>	<b>Rate (lb/acre)</b>
Meadow foxtail (common)	18
Hard Fescue (Durar)	18
Red fescue (arctared)	27
Annual ryegrass (Lolium multiflorum)	27
<b>Fertilizer</b>	<b>Rate (lb/acre)</b>
First year (apply with seed)	
10(N) – 20(P) – 10(K)	358
33-0-0	90

Table 2-2  
Revegetation for tundra areas

### 3. WATER SOURCE DEVELOPMENT

**3.1 GENERAL.** Both ground and surface waters are available in the Arctic and Subarctic but the environmental conditions require somewhat special approaches for their development. In addition, ice and snow are sometimes used for water supply augmentation or as emergency or stand-by sources.

**3.2 ENVIRONMENTAL CONSTRAINTS.** In most of the Arctic and Subarctic, precipitation is light, terrain is relatively flat and runoff is concentrated in the short period during ice breakup. There are many small, shallow lakes and ponds and numerous rivers and streams. Ice cover varies according to local conditions but generally lasts from 6 to 10 months and approaches 6 feet in depth in small quiescent water bodies. Hydrologic data for these regions are scarce so it is difficult to predict reliable yields. Permafrost is essentially impermeable so there is little direct recharge of most aquifers. Any penetration of the permafrost for exploration or for well development requires special engineering consideration and is costly.

**3.3 SURFACE WATERS.** Many shallow lakes and small streams freeze completely in the winter, eliminating them temporarily as a water source. Some installations pump water from such sources in the summer months and store the winter supply. Larger streams and deep lakes can have liquid remaining beneath the ice but the volume available is limited since there is no contribution from precipitation in the winter. The large quantity of ice and snow results in major annual flows occurring during the spring "break-up." Figure 3-1 shows a hydrograph for a typical medium-sized arctic river.

**3.3.1 RIVERS.** The volume of flow is low in the winter but water quality is excellent since sediment transport from glacial sources is minimal and surface runoff recharges do not occur. Winter water temperatures are very low (33 degrees F), which creates difficulties for treatment, and intakes can clog due to formation of frazil ice. Floating ice during freezeup and breakup periods can damage or

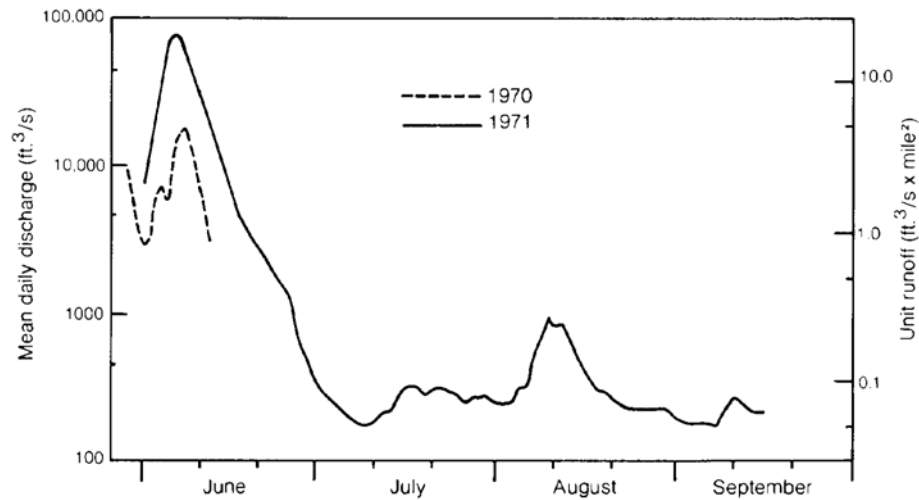

Figure 3-1  
Hydrograph of mean daily discharge Kuparuk River

destroy intake structures. Some facilities remove the intake structure during those periods and rely on temporary storage. Development of intake galleries or wells in the stream bottom is successful for avoiding ice problems, but it is difficult to locate the permanent channel in alluvial and braided streams. The summer flows are higher in volume than the winter flows but they are poorer in quality, containing sediments and glacial silts which may be difficult to remove. For example, the Kenai River near Soldotna, Alaska, has suspended sediment concentrations up to 151 milligrams per liter (mg/L) economical in the summer months. These sediments are primarily glacial silts and are almost colloidal in size.

**3.3.2 LAKES.** Deep lakes are a reliable, continuous source of water. The quality of any liquid beneath the ice in a shallow lake or pond is typically poor. Impurities, such as most salts, are rejected from the freezing water, making the ice relatively pure but concentrating the impurities in the remaining liquid. A survey is required to identify lakes and ponds that may freeze deeply enough to create this condition.

**3.3.3 SALINE WATERS.** Distillation or reverse osmosis is used to treat saline or brackish waters; these procedures are costly and energy intensive, so such sources will be avoided except as the last resort.

**3.3.4 AUGMENTATION.** In the Arctic most of the annual precipitation is in the form of snow. Although total precipitation is low, advantage can be taken of the windy conditions to induce snow drifting at selected locations. Collection of the melting snow augments the summer water supply. Snow fences were used to induce drifting in the watershed of the Barrow, Alaska, water reservoir. It was shown that at least 800 gallons of water was collected for every linear foot of 5-foot-high snow fence that was installed, with the fences about 250 feet apart.

**3.4 GROUND WATER.** Ground water can be a more reliable water source than surface supplies. It is usually available on a year-round basis and is more consistent in its temperature and mineral quality than surface sources. Very shallow ground waters are unsuited for potable water supplies without extensive treatment and the yield is limited. Subpermafrost ground water or permafrost zones thawed by large rivers and lakes are the most reliable sources. Subpermafrost wells are technically feasible when the permafrost extends to a depth of a few hundred feet or less and they have been successfully used in central Alaska. Costs for drilling and maintenance of such wells are high. The water must be protected from freezing and the permafrost must be maintained in a frozen condition. This requires special well casings or grouting methods and unique operational methods. Subpermafrost water is generally deficient in dissolved oxygen and can also contain high concentrations of dissolved iron and manganese salts. Hardness is also common. Dissolved organics can also create serious treatment problems due to interactions with the dissolved iron and the color imparted to the water. The most reliable and economical ground water sources in the Arctic and Subarctic are in the thawed zones adjacent to large rivers and lakes. Most of the rivers are braided streams and have shifted their channels many times. The former stream channels may still be underlain by thawed material and represent a potential water source depending on the type of soils involved.

**3-5. OTHER WATER SOURCES.** Snow, ice and direct catchment of rainfall are potential water sources that must be considered for augmentation or emergency supplies and for small or temporary facilities. The natural quality of these sources is good but a stockpile of snow or ice can be easily contaminated. Large volumes of snow are required to produce even small quantities of water and the costs for harvesting and melting are high. It is estimated that 4 to 5 cubic feet of snow are required for every 5 gallons of water produced, and to melt this volume of snow would require about a pint of diesel fuel for the snow melter. Brackish and saline ponds have been improved in quality by pumping out the concentrated brines that remain under the ice near the end of the winter and allowing fresh spring runoff to recharge the pond. If repeated several times the procedure allows the use of an initially unacceptable water source.

**3.6 STRUCTURES.** Structures range from wells and their appurtenances or simple temporary intakes on river ice to a complex dam structure located on permafrost. The complete structural design of any of these is beyond the scope of this publication. It is the intent of this section to point out those features that may require special attention in the cold regions.

**3.6.1 RIVER INTAKES.** A permanent intake structure will usually be employed for large-scale permanent facilities in the Arctic. Structural damage from moving ice in the spring and in the fall is the major concern.

**3.6.1.1 TEMPORARY INTAKES.** These are less expensive, and are removed from the river during spring ice breakup, and storage is relied on as the water supply. This approach is suitable for small populations. A temporary intake consists of a pump and a simple shelter.

**3.6.1.2 PERMANENT CONSTRUCTION.** Numerous arrangements and configurations have been designed. Figure 3-2 illustrates the intake in the river at Fort

Norman, Northwest Territories, Canada. Figure 3-3 illustrates the water intake at Cambridge Bay, Northwest Territories, Canada. Special features of this design include the insulation provided, heat tracing in the wet well and in the intake line, and the recirculating line from the town site. Dual intakes are recommended to ensure reliability. Continuous water circulation is then used to prevent freezing. Frazil ice can be a serious problem for intakes during the freeze-up period. Frazil ice occurs as small crystals in flowing water slightly below 32 deg F temperature. It will adhere to and accumulate on any submerged object it contacts. Water intakes, trash racks and similar structures can become completely choked by frazil ice in a few hours. It can be avoided by locating the intake in a long calm reach of the river where surface ice will occur before the water becomes supercooled. The surface ice cover then prevents rapid heat loss and precludes frazil ice formation. Heating the intake and bar screens to about 33 degrees F will prevent formation of frazil ice. This can be done electrically or by backpumping hot water or steam.

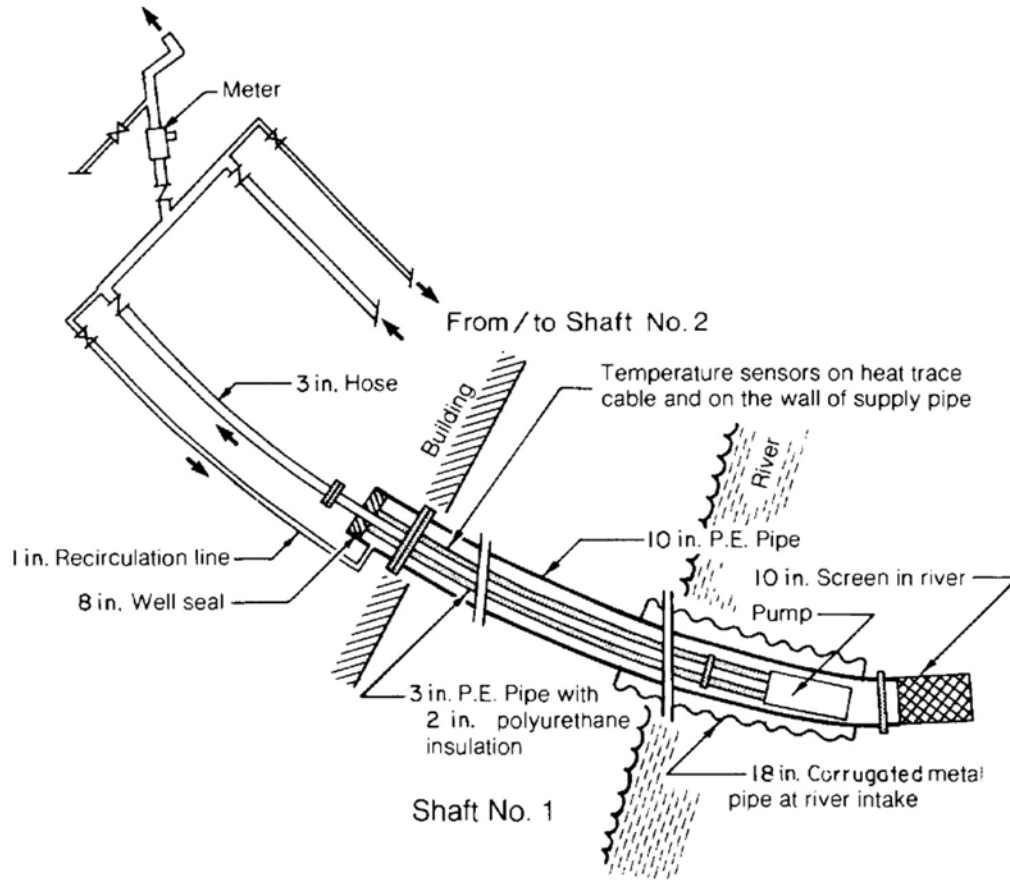

Figure 3-2  
Piping schematic for water intake

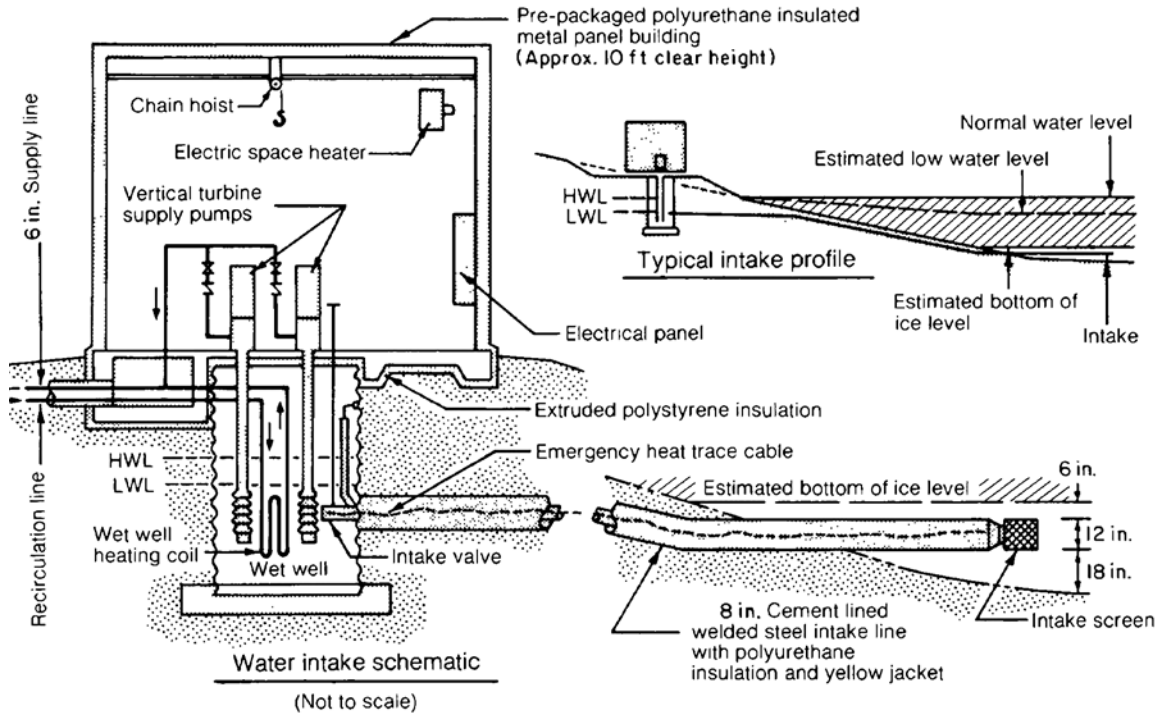

Figure 3-3  
Water intakes

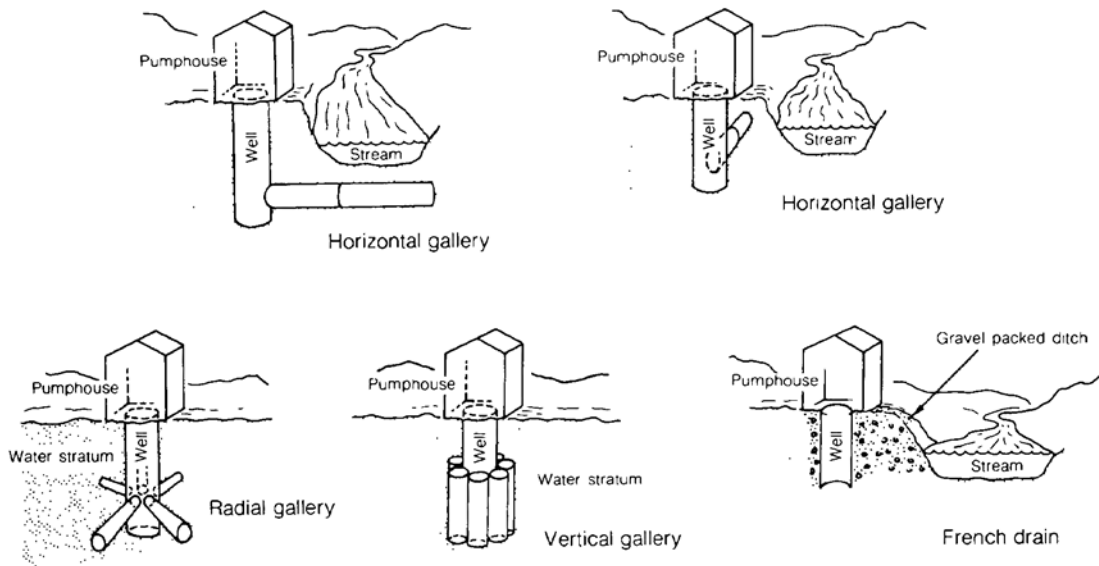

Figure 3-4  
Infiltration galleries



**3.6.2 INFILTRATION GALLERIES.** Infiltration galleries remove the structure from risk of ice damage and thereby offer advantages over direct intakes. Figure 3-4 illustrates several configurations of infiltration galleries that have been used successfully in the cold regions. The gallery is placed in thawed material in the stream bed or adjacent to it. The yield will depend on the type of soil present. Importation of coarse-textured material will be necessary for gallery construction in fine-textured silty and clayey soils. Both electrical and steam lines have been used in galleries to prevent freezing. Steam lines are usually placed on the upper surface of the intake laterals and on a second level about 1.5 feet above that. The heating elements or steam lines are not normally operated continuously but are used only in emergencies to restore a frozen or partially frozen system. Springs can also be developed with these same techniques.

**3.6.3 WELLS.** The special concern for subpermafrost wells is not to allow thawing of the permafrost during drilling and during operation of the well. The former may require either compressed air or non-toxic drilling muds or fluids with rotary drilling procedures. Avoidance of permafrost thawing during well operation may require multiple casings so that cold air can circulate in the annular spaces. Concurrent with protection of the permafrost is the necessity of maintaining the water in an unfrozen state and this will require heat addition for an intermittently used system. Figure 3-5 illustrates a typical cold regions well with a submersible pump in non-permafrost conditions but designed for frost and heave protection in the surface soils. Bentonite, mixtures of oil, wax and sand, and various plastic coatings have been used on these casings to prevent the bonding between the frozen soil and the pipe and thereby eliminate heave damage. Figure 3-6 illustrates the critical features in the well head and pump house design for larger facilities.

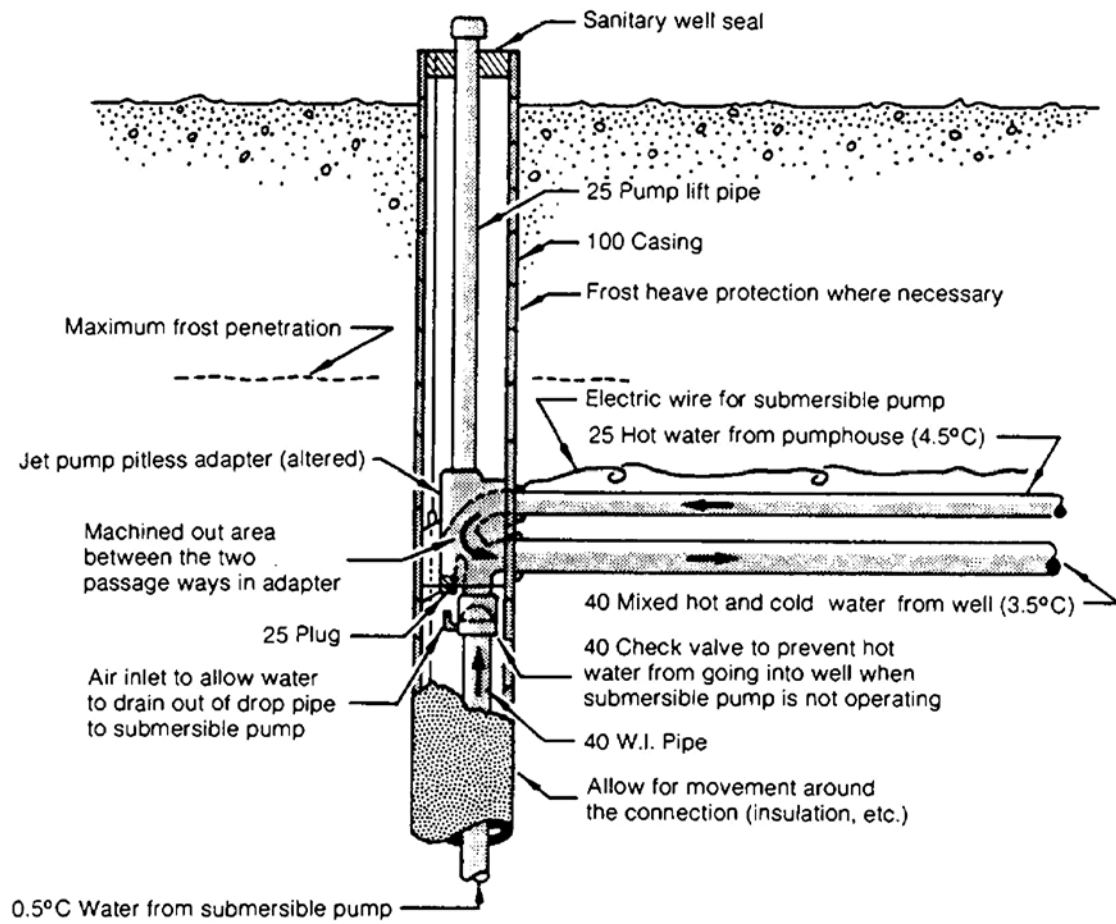

Figure 3-5  
Well seat

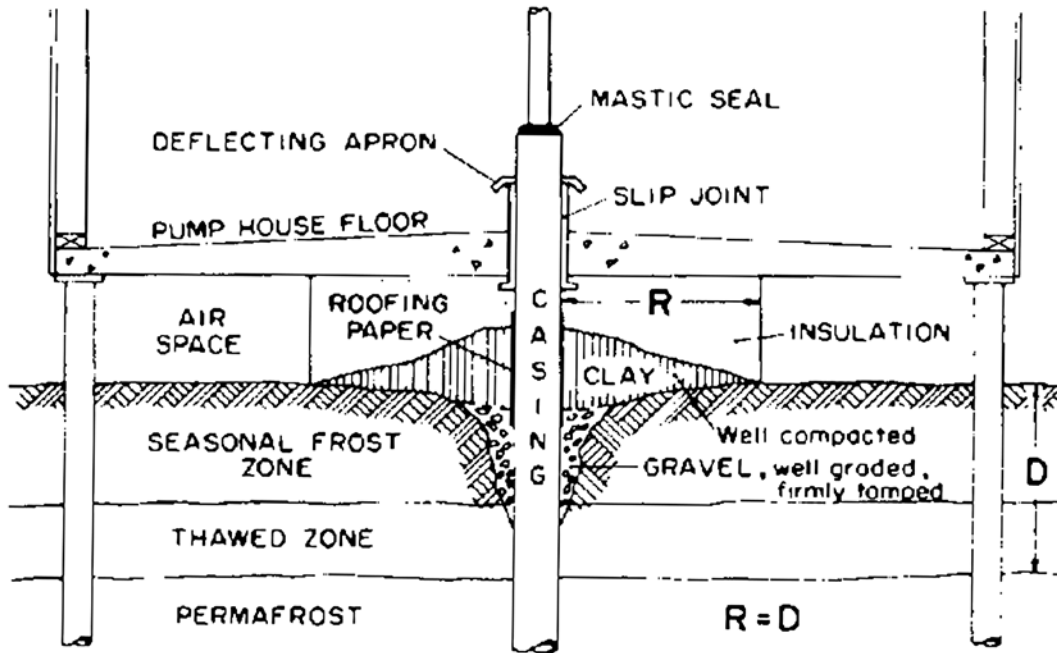

Figure 3-6  
Casing head construction for water well in shallow permafrost  
when surface soils are susceptible to heaving

## 4. WATER TREATMENT

**4.1 GENERAL.** This chapter will discuss only those aspects unique to the Arctic and Subarctic. There are three major process concerns: the low temperature of the raw water, removal of glacial silt from surface sources and removal of dissolved minerals and organics from surface or groundwater sources.

**4.2 TEMPERATURE EFFECTS.** The temperature of surface water sources during winter will be at or very near 32 degrees F, while groundwater sources in permafrost regions may be a few degrees warmer and maintain that level year round. The water must be preheated to at least 40 to 50 degrees F or the unit processes must be designed for low temperature operation. The effect of low temperatures on equipment operations must also be evaluated during facility design.

**4.2.1 PREHEATING.** A number of methods have been successfully used to heat water in arctic systems. Safeguards are necessary to avoid contamination (and cross connections) during the heating process and the corrosion induced if dissolved oxygen is released from solution. Very cold surface waters may be at or near saturation with respect to dissolved oxygen. Oxygen is then released as a gas as the water is warmed and can cause severe corrosion in iron and steel pipes, pumps, and tanks. Use of non-ferrous metals in the heating stage and controlling the release point for this oxygen will reduce corrosion problems.

**4.2.1.1 LIQUID-LIQUID HEAT EXCHANGERS.** Hot water is the preferred source of heat for these devices to eliminate problems from tube leakage and contamination. The source of hot water might be a central heating system or cooling water from an engine. Double wall, or double liquid to liquid exchangers are necessary to prevent any possibility of contamination of potable water.

**4.2.1.2 BLENDING.** In some cases a source of clean hot water may be available and can be blended directly with the cold water to achieve the desired temperatures. Condenser water from a steam system was successfully used in this way in Fairbanks, Alaska.

**4.2.1.3 DIRECT-FIRED BOILER.** These systems use oil, gas or coal furnaces to maintain the contained water at just below boiling temperature. This is then blended with the cold water source or used in a heat exchanger.

**4.3 LOW TEMPERATURE TREATMENT.** Almost all of the physical, chemical, and biological processes used in water treatment are sensitive to temperature either through viscosity effects or as an influence on reaction rates. A multiplier must be used to adjust the design of a water treatment process component for temperature.

**4.3.1 MIXING.** Mixing is strongly dependent on temperature because of viscosity changes in the water. The power input for mechanical flocculation is directly dependent on fluid viscosity as defined by:

$$P = G^2 V \mu \quad (\text{eq 4-1})$$

where

P = power input

$G^2$  = velocity gradient

V = tank volume

$\mu$  = absolute fluid viscosity.

To maintain the same velocity gradient in the tank as the liquid temperature decreases, it is necessary to adjust the 68 degree F power requirement by a multiplier. This relationship will be valid for any kind of mechanical mixing. Detention time for mixing is determined separately. Detention times for flocculation range from 15 to 30 minutes and

tend to be arbitrarily based on successful performance. The multiplier must be used for this adjustment. Multiple basins are recommended when surface water is the source and warmer temperatures are expected in the summer. In this way some of the units can be taken out of service when not needed.

**4.3.2 SEDIMENTATION.** Settling of discrete particulate material is retarded by the increased viscosity in cold waters. The effect of low temperature decreases as the solids concentration increases. Plain gravity sedimentation of individual particles would be subject to full viscosity effects and the detention time must be adjusted with multipliers.

Upflow and sludge blanket clarifiers are not as sensitive to viscosity effects and the multipliers will be used in these cases (solids concentrations >2000 mg/L). Another concern for any type of clarifier is the presence of density currents induced by strong temperature differences between the incoming fluid and the tank contents. These currents will disrupt the settling process and are particularly critical for upflow clarifiers. If possible these units will be maintained at nearly constant temperature and the incoming fluid adjusted to that same level.

**4.3.3 FILTRATION.** Filtration is influenced by low temperature since the head loss through the filter is proportional to viscosity. Mixed media filters will provide a more efficient use of space in cold regions facilities. The multiplier values from figure 9-1 will be used to adjust filtration efficiency. Backwashing of filters is also affected since power for pumping will vary with temperature, due to the increased water viscosity. The minimum upflow velocities will be reduced because of the increased fluid density at low temperature.

**4.3.4 DISINFECTION.** Appropriate references should be consulted for basic criteria on disinfection procedures, chlorine dosages and residuals. The solubility rate of chlorine decreases at very low water temperatures, but for practical purposes this will not occur

at the dosage rates commonly used. The effectiveness of chlorination is hindered in cold water, and the exposure times must be increased in order to provide adequate disinfection. Contact time of about 1 hour is recommended for cold water below 40 degrees F.

**4.3.5 FLUORIDATION.** If fluoridation is practiced at remote cold regions facilities, the U.S. Public Health Service (USPHS) recommends that the dosage should be increased since the actual per capita consumption of drinking water tends to be somewhat less than in temperate locations. Fluoride concentrations of about 1.4 mg/L are recommended for the Arctic and Subarctic. Table 4-1 relates the USPHS recommended fluoride limits to the annual average air temperature at the design location.

Annual Average (5 yr +) Maximum Air Temperature (°F)	Fluoride Limits (mg/L)		
	Lower	Optimum	Upper
54	0.9	1.4	2.4
54-58	0.8	1.1	2.2
58-63	0.8	1.0	2.0
63-70	0.7	0.9	1.8
70-80	0.7	0.8	1.6
80-90	0.6	0.7	1.4

Table 4-1

**4-4. REMOVAL OF MINERALS AND ORGANICS.** Ion exchange water softening is commonly used at smaller installations with hard water. Lime-soda softening is frequently used when the water is both turbid and has a high hardness. Dissolved iron is common in cold regions ground waters and can foul zeolite and greensand ion exchange resins so that it must be removed prior to ion exchange processes. Aeration or chemical oxidation with chlorine have been successful for precipitation of elemental iron. However, iron/organic complexes are present in many cold regions groundwaters.

Ozone has been shown to be effective in treating such waters. Ozone and carbon adsorption are very effective for color and organics removal.

**4.5 TREATMENT OF BRACKISH AND SALINE WATERS.** Distillation, reverse osmosis and freezing have all been used in the cold regions to reduce salt concentrations to potable levels.

**4.5.1 DISTILLATION.** Distillation is expensive, requiring relatively high skill levels to accomplish, and will be considered only if other alternatives do not exist.

**4.5.2 REVERSE OSMOSIS.** Reverse osmosis (RO) is temperature sensitive, with best results obtained when water temperatures are in the range of 68 to 85 degrees F, and the cost is also high. Packaged reverse osmosis units are available from about 1000 to 1,000,000 gallon/day capacity (gpd). Power requirements are approximately one kilowatt-hour of power for each 100 gallons of potable water produced. These RO systems must be protected from freezing at all times, from the point of manufacture, during storage and during use.

**4.5.3 FREEZING.** This process takes advantage of natural low temperatures to separate the saline brine from the ice which is then melted (naturally in the spring and summer) and used for water. Trenches have been filled with brackish water, allowed to freeze several feet deep, and then the remaining liquid under the ice pumped out. Spray freezing involves sprinkling brackish water through a nozzle to form a large cone of ice, with the brine draining away continuously during the winter. In a pilot-scale test in Saskatchewan, chloride content was reduced from 2000 mg/L to 500 mg/L in the melted ice. The recovered water represented about 75 percent of the volume sprayed.



## 5. WATER STORAGE

**5.1 GENERAL.** Basic criteria for determination of capacity requirements and for design and construction of water storage facilities can be found in the professional literature. This section discusses only those aspects unique to the Arctic and Subarctic. Water storage is provided for domestic and fire protection services. The requirements for water will typically be lower at remote facilities in the Arctic and Sub- arctic than at similar operations in the temperate zone due to conservation and lower external water needs. The water needs will vary with the type of facility, so general criteria are not possible. A special design study to determine specific water needs will be undertaken for each new facility so that cost- effective designs for water supply, water storage and wastewater systems can be ensured.

**5.2 TANK MATERIALS.** Common construction materials for water tanks include wood, steel, and concrete. Wood stave tanks are constructed with prefabricated pieces that can be shipped relatively easily to any remote site. Leakage is a problem with intermittent or fill-and-draw operations since the joints can open slightly if the wood is allowed to dry. Figure 5-1 illustrates the cross-sectional details of a wooden tank with an internal liner and insulation constructed in the Canadian Arctic on a pile foundation. In Alaska welded steel tanks are most commonly used. Tanks have been insulated with polystyrene or polyurethane boards or with sprayed-on polyurethane. Figure 5-2 shows a welded steel tank with board insulation and metal cladding resting on an insulated gravel pad. Concrete tanks have been used where aggregate is available and the foundation conditions permit slab construction. Concrete tanks will be covered with earth and insulated if necessary reduce heat losses as shown in figure 5-3. Seismic conditions must be evaluated prior to selection of a rigid concrete tank. Welded steel tanks are more cost effective for high-risk seismic areas.

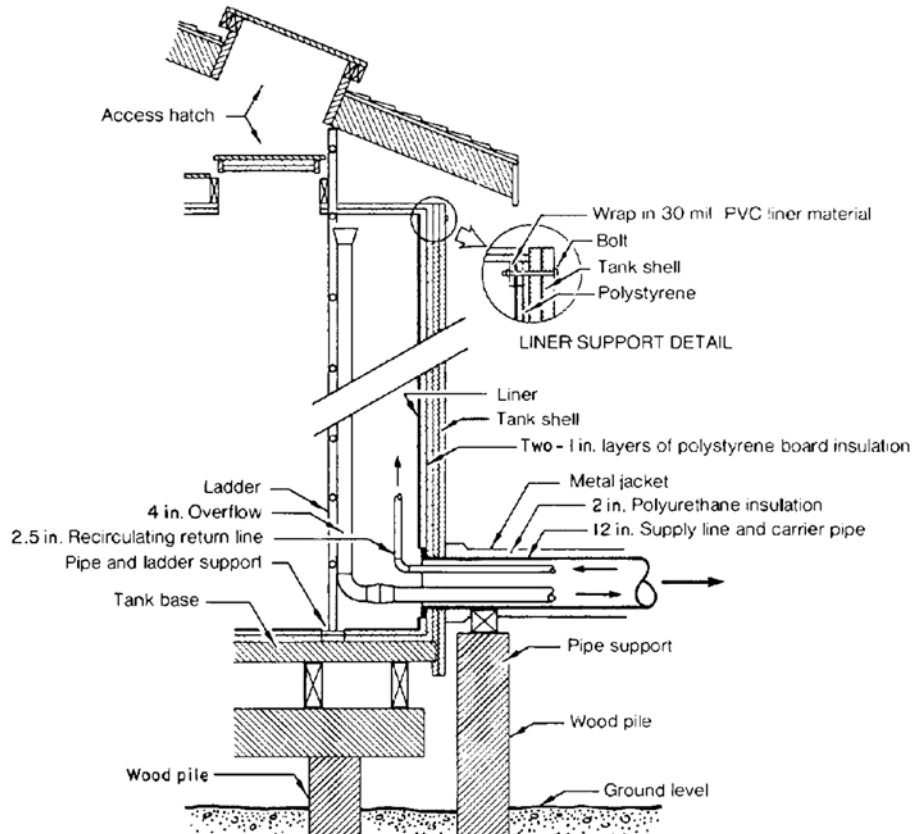

Figure 5-1

Wood tank with insulation and liner on inside

**5.2.1 CORROSION PROTECTION.** Steel water tanks must be painted in accordance with applicable standards. Manufacturers' recommendations regarding acceptable temperature limits for the application of these paints must be strictly followed to avoid premature failure. The cost of sandblasting and liner replacement is very high in remote locations so that the type of coating initially selected should be of high quality and properly applied. Cathodic protection is also required.

**5.2.2 INSULATION.** Successful tank insulation has been provided by earth cover, wood, glass fiber, cellular glass, polyurethane and polystyrene block materials. Tanks can also be enclosed with a protective shell. Such an exterior shell is either constructed against the tank or a walkway provided between the tank and the exterior wall as shown in figure 5-4. The air gap and the wind protection will reduce heat losses,

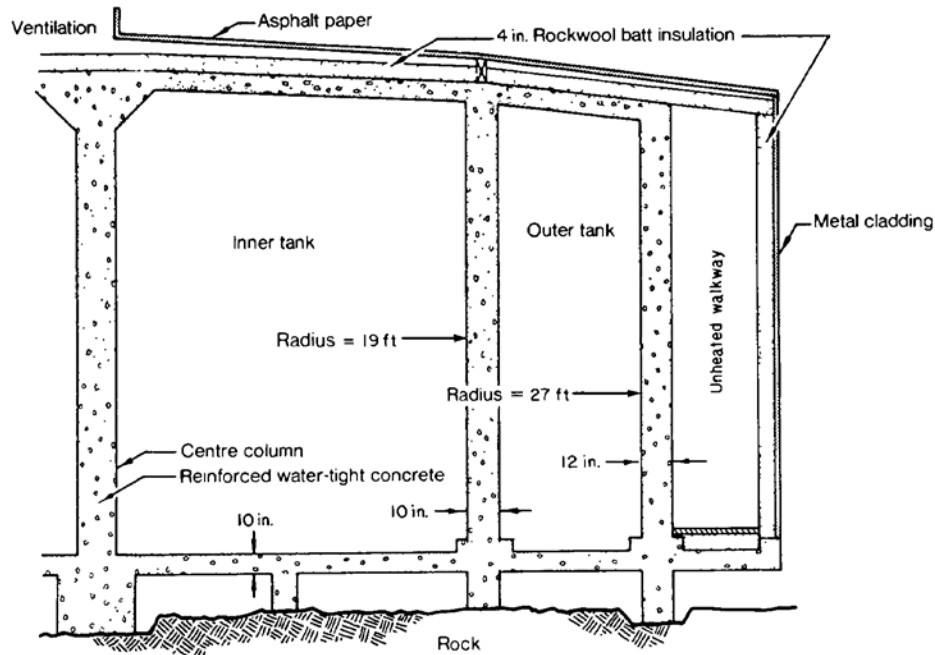

Figure 5-4  
Above-ground concrete tank, Greenland

and this heat loss reduction can be further enhanced by installing insulation. Moisture-resistant insulation materials must be installed in contact with the tank at inaccessible locations since moisture from leaks, condensation, rain or ground water can drastically reduce the insulating effect.

**5.2.3 FOAM INSULATIONS.** Near-hydrophobic plastic foam insulations are readily available and commonly used. Polyurethane can be obtained as either prefabricated boards or foamed in place by spraying directly onto the tank. The latter has been the more common approach in Alaska. To ensure a good bond all loose scale or paint flakes are removed, the surface solvent-cleaned if it is oily, and a compatible primer applied. Foaming-in-place requires a dry surface, winds less than 3 miles per hour, air temperatures above 36 degrees F and tank surface temperatures above 50 degrees F. The hardened foam must then be protected from vandalism, weather and ultraviolet light. This is commonly done with low temperature elastomers or similar coatings compatible with polyurethane that are sprayed onto the insulation. Two or three coats are recommended with the first application within one day of foam application.

Polystyrene or polyurethane boards can be glued and strapped (with 1-1/2 inch wide stainless steel banding, 18 inches on center) to the exterior of the tank. Large tanks will require clips. The insulation boards will be less than 3 inches thick to allow installation on a curved tank surface. Two layers of insulation are preferred so that the joints between boards can be staggered (see figure 5-2). Sheet metal cladding is then applied for weather and vandal protection. Insulation boards composed of high density foams (compressive strength about 1500 psi) are sometimes placed under a tank (figure 5-3) for protection of the frozen subgrade.

**5.3 TANK DESIGN.** Water storage tanks must be designed to prevent the formation of ice in the tank under all foreseeable circumstances and tanks must be completely drainable. Floating ice in the tank can destroy interior appurtenances, and ice formed on the walls can collapse and cause structural failure or punctures in the tank bottom. Surface icing can be avoided by maintaining the water temperature above 39 degrees F and there will be a continuous circulation. In some cases the return line of a circulating water distribution system is discharged to the storage tank to promote circulation and maintain temperatures. In other cases a small amount of water is withdrawn, heated with a boiler or heat exchanger and pumped back into the tank.

**5.3.1 APPURTENANCES.** Breather vents will be located on the inside of the tank and vented into an attached pumphouse or building rather than directly to the outside. Ice will form in an exposed vent due to condensation and a vent blocked with ice will result in a vacuum in the tank as water is withdrawn and possibly cause the tank to collapse. Overflow piping will either be inside the tank or protected with insulation and heat tracing if placed on the exterior. Since ice can damage float type water level indicators, the pressure transducer type is recommended. Temperature monitoring at various levels for control and for alarms will be included in the design.

**5.3.2 THERMAL CONSIDERATIONS.** Whenever practical, tanks must be buried or covered with soil to reduce the effect of low air temperature. Elevated tanks must be avoided unless they are absolutely necessary for the water distribution system since

they expose the greatest surface area to the worst climatic conditions. All exposed tank surfaces and risers for elevated tanks must be insulated. The economical thickness of insulation can be determined by appropriate calculation procedures. Thermal calculations are also necessary to size the heating systems used to replace heat losses or to heat the water for distribution. The unit capacity of a heat exchanger or boiler must be equal to the maximum rate of heat loss.

**5.4 TANK FOUNDATIONS.** Foundation considerations are similar to those for other arctic and subarctic structures. Foundation design for tanks is complicated by the very high loads imposed by the stored water and the need to keep the water in the unfrozen state. The unfrozen water is a heat source that can have an adverse effect on the underlying permafrost and must be considered during design for a tank on grade.

**5.5 EARTH RESERVOIRS.** Water impoundments for domestic and industrial water supply and for hydropower have been successfully constructed in the Arctic and Subarctic. The most likely configuration for facilities is an earthen embankment to either increase the storage capacity of an existing lake or stream or to impound water in a natural drainage swale. Construction of these embankments must be in accordance with professional standards. A liner is necessary within the embankment or to seal the entire reservoir, when permeable soils are present or used for construction. Successfully used liner materials include Hypalon synthetic rubber, chlorinated polyethylene (CPE) and elasticized polyolefin. (See EPA 600/8-79-027 for further detail on linings.)