



PDHonline Course M487 (4 PDH)

Basic Electrical Engineering for HVAC & Mechanical Engineers

Instructor: A. Bhatia, B.E.

2020

PDH Online | PDH Center

5272 Meadow Estates Drive
Fairfax, VA 22030-6658
Phone: 703-988-0088
www.PDHonline.com

An Approved Continuing Education Provider

Basic Electrical Engineering for HVAC & Mechanical Engineers

A. Bhatia, B.E.

Introduction

An HVAC system is a simple system of heating and cooling exchangers using water or refrigerant (direct expansion system) as the medium. Pumps move the heated or cooled water to the exchangers. Fans then move the warmed or cooled air created at the exchangers to the occupied building interiors.

So there are two stages to heating and cooling

1. Water stage: water is the most efficient and inexpensive medium that we can cool directly (through a chiller) or heat (through a boiler)
2. Air stage: air is the medium for heat exchange in the building, as it can be cooled or heated through coils.

Figure below illustrates a typical HVAC system showing water and air heat exchangers:

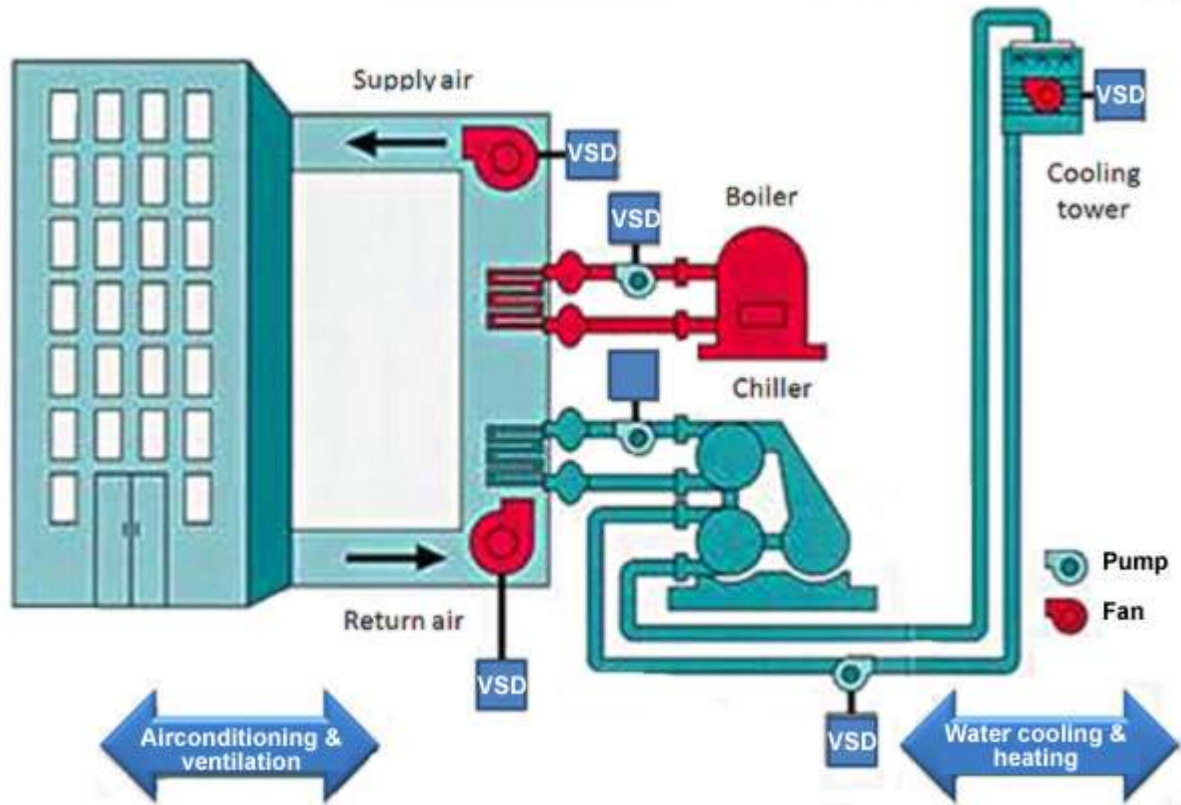

Big energy users in HVAC

1. Fans: for air circulation and ventilation.
2. Cooling: accomplished via chillers for the production of chilled water for large buildings or the use of direct expansion cooling systems such as packaged air-conditioners for small buildings.
3. Heating: most frequently, the energy use of boilers for the production of hot water for heating, but also often the use of electric heaters for zonal reheat.
4. Pumps: for the circulation of heating hot water, chilled water and condenser water.
5. Cooling towers: for heat rejection. The primary energy use is the cooling tower fan and pumps.

Power distribution systems and equipment used to drive HVAC machinery, motors and other auxiliaries can be complex to the non-electrical engineer. This course will address some basic

electrical concepts that will be useful to HVAC engineers and other mechanical engineers in their day to day work. The course is divided in 4 sections:

- Part -1: Basic Electrical Concepts & Fundamentals
- Part -2: Electrical Distribution Systems and Components
- Part -3: Motors and Variable Speed Drives
- Part -4: Electrical Energy Efficiency in HVAC Systems

PART -1: BASIC ELECTRICAL FUNDAMENTALS

In each plant, the mechanical movement of different equipment's is caused by an electric prime mover (motor). Electrical power is derived from either utilities or internal generators and is distributed through transformers to deliver usable voltage levels.

Electricity is found in two common forms:

1. AC (alternating current)
2. DC (direct current)

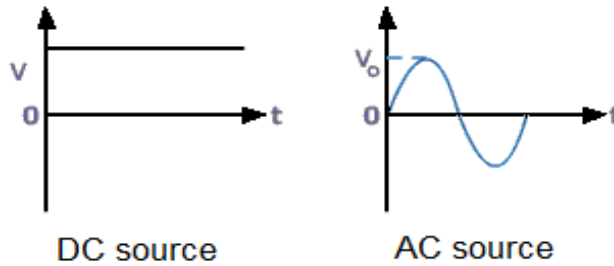

The selection of energy source for equipment depends on its application, each having its own merits and demerits but for HVAC system or typical building services, we are concerned with AC voltage.

Industrial AC voltage levels are roughly defined as LV (low voltage) and HV (high voltage) with frequency of 50–60 Hz. An electrical circuit has the following three basic components irrespective of its electrical energy form:

1. Voltage (V) is defined as the electrical potential difference that causes electrons to flow.
2. Current (I) is defined as the flow of electrons and is measured in amperes.
3. Resistance (R) is defined as the opposition to the flow of electrons and is measured in ohms.

All three are bound together with Ohm's law, which gives the following relation between the three:

$$V = I \times R$$

In a more technical expression, you can state it as:

With Constant Resistance

- Lower voltage gives small current.
- Higher voltage gives large current.

With Constant Voltage

- Lower resistance passes large current.
- Higher resistance passes small current.

Example: A conductor has a resistance of 1.5 ohms and the current flowing on the wire is 5 amperes. The voltage drop along the wire will be the current times the resistance of the conductor or 7.5 volts.

Example: A resistance type heating element from an electric water heater operating at 240 volts has a current flow of 14.6 amperes. The resistance of the heating element will be the voltage divided by the current or 16.4 ohms.

CIRCUITS

In order to flow, electricity must have a continuous, closed path from start to finish – like a circle. The word “circuit” refers to the entire course an electric current travels, from the source of power, through an electrical device, and back to the source. Every circuit is comprised of three major components:

1. A conductive "path," such as wire, or printed etches on a circuit board;
2. A "source" of electrical power, such as a battery or household wall outlet, and,
3. A "load" that needs electrical power to operate, such as a lamp.

The current flows to the devices (called loads) through a “hot” wire and returns via a “neutral” wire –so- called because under normal conditions it’s maintained at zero volts, or what is referred to as ground potential.

There are also two optional components that can be included in an electrical circuit. These are control devices and protective devices. Control and protective devices, however, are not required for a circuit to function. They are optional. For example, a circuit that switches on an air conditioner when the temperature is too high would contain the following components:

- a source of electrical energy, in this case, simple household current;
- a protective device that senses current flow on the circuit, the circuit breaker in the panel box,

- a control device that redirects the current, the switch in the thermostat;
- a load such as an air conditioner that cools the space down until the circuit opens shutting the air conditioner off.

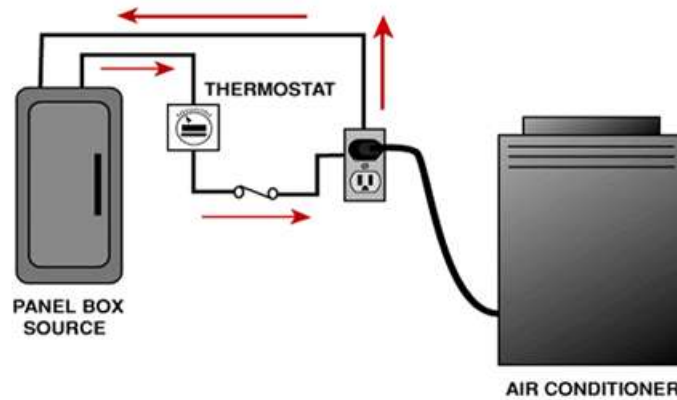

Types of Circuits

There are several types of circuits. Their names describe the way the circuit is wired, or its main function. Elementary types of circuits include:

- Series
- Parallel
- Open
- Short
- Power
- Control

Series Circuit:

A series circuit is defined as a circuit in which the elements in a series carry the same current, while voltage drop across each may be different. It has only one path for current to flow through the circuit. A typical series circuit is shown below:

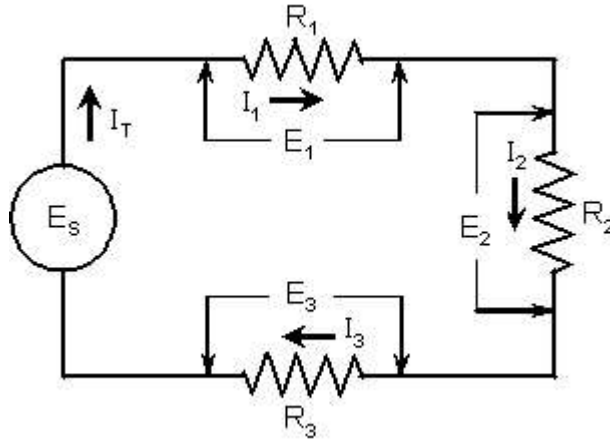

Here are the basic rules of a series circuit.

- Current: In a series circuit the current (I) in amperes is the same everywhere in the circuit.

$$I_T = I_1 = I_2 = I_3$$

- Voltage: The total voltage of the circuit will be the sum of the voltages across each of the resistors in the circuit.

$$V_T = V_1 + V_2 + V_3$$

- Resistance: The total resistance of the circuit will be the sum of the individual resistors in the circuit.

$$R_T = R_1 + R_2 + R_3$$

Parallel Circuit:

A parallel circuit is defined as a circuit in which the elements in parallel have the same voltage, but the currents may be different. It has multiple paths for the current to follow as shown in the figure below:

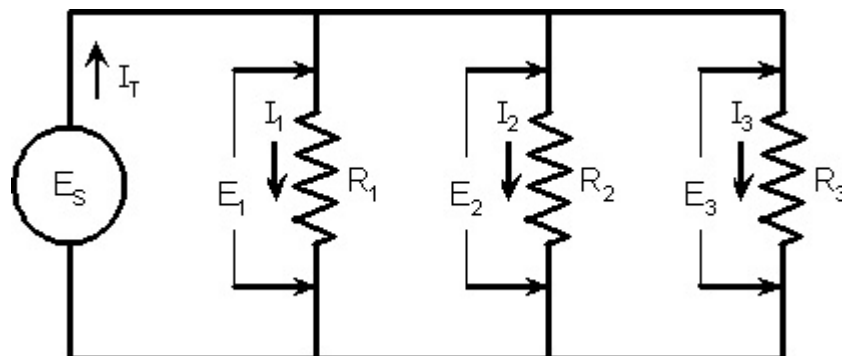

Basic Rules

- Voltage: The voltage will be the same across all resistors in the circuit and it will be equal to the supply voltage.

$$V_T = V_1 = V_2 = V_3$$

- Current: The total current (I) in amperes flowing in the circuit will be the sum of the currents through each parallel branch of the circuit.

$$I_T = I_1 + I_2 + I_3$$

- Resistance: The total resistance of a circuit where all resistors are in parallel is a little difficult to determine. The reciprocal of the total resistance is the sum of the reciprocals of each resistance. It is very important to note that the total resistance will be smaller than the smallest resistance in the circuit. If all the resistors are of the same value, then just divide the resistance by the total number of resistors. A good way to solve for the total resistance is to assign a voltage to the circuit and then determine the total current flow. Then divide the voltage by the total current flow using Ohm's law to get the total resistance.

$$\frac{1}{R_T} = \frac{1}{R_1} + \frac{1}{R_2} + \frac{1}{R_3}$$

Open Circuits:

An open circuit is a circuit where the path has been interrupted or "opened" at some point so that current will not flow. An open circuit is also called an incomplete circuit.

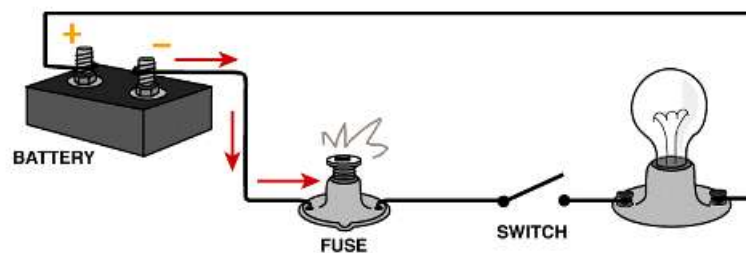

An open circuit could be intentional or un-intentional. An intentionally open circuit would be the circuit to the lights in the room that are turned off. There is no closed path available for the electricity to flow to the lights because the switch is in the "off" position which "opens" the path the electricity would normally flow through.

An example of a circuit that is un-intentionally open is when a circuit breaker operates due to too much current on the circuit and shuts the circuit off. The common electrical industry terminology would be to say that the circuit breaker or fuse "opened" or tripped the circuit. It did this by "opening" the switch in the circuit breaker.

Short Circuits:

A short circuit is a circuit in which the electricity has found an alternative path to return to the source without going through an appropriate load. You can demonstrate this easily by taking a fine piece of wire and connecting it to both the positive and negative terminals of a small battery. The wire will heat instantly and probably melt. In most circuits, this high amperage represents a dangerous situation that could cause a fire or electrocute someone.

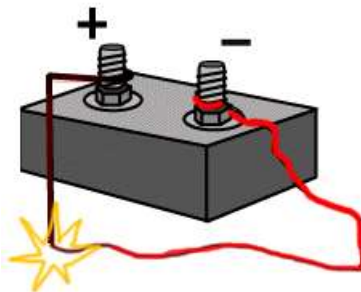

Power Circuits:

A power circuit is defined as any circuit that carries power to electrical loads. Power circuits often carry high voltages and consist of incoming main power, a motor starter, and the motor. This may seem like a simplistic definition but it is important to distinguish power circuits from control circuits since they serve different purposes.

Control Circuits:

A control circuit is a special type of circuit that uses control devices to determine when loads are energized or de-energized by controlling current flow. Control circuits usually carry lower voltages than power circuits.

Consider a 600 hp large industrial motor driving a water pump. The motor is connected to a high voltage electrical supply of 680V. When this motor is energized, it must draw enough current to get the water moving and it is common for a motor to draw about six times its normal operating current for a short period of time. This can be troublesome.

- The first concern is the operator's ability to safely close the switch.

- The second concern is that when the operator opens the switch to turn the motor off, the electricity will continue to try to complete the path. This will tend to arc between the contacts of the switch as it is opened. This arcing is not only dangerous but also damages the switch by severely burning the contact points.

A control circuit is used to ensure that the motor is started and stopped in a safe manner for both the operator and the equipment.

A common control circuit example is the thermostat to the air conditioner. The thermostat is part of a low-voltage control circuit that controls a relay that actually energizes and de-energizes the power circuit to the air conditioning compressor.

POWER (P)

In DC circuits, power (watts) is simply a product of voltage and current.

$$P = \text{Volts} \times \text{Amps}$$

For AC circuits, the formula holds true for purely resistive circuits; however, for the following types of AC circuits, power is not just a product of voltage and current.

- Single-phase power:

$$\text{Power (kW)} = \text{Volts} \times \text{Amps} \times \text{power factor}$$

- 3-phase power:

$$\text{Power (kW)} = 1.73 \times \text{Volts} \times \text{Amps} \times \text{power factor}$$

Power consumption:

The total amount of energy used is estimated by multiplying the power by the length of time the load is on. This is most commonly expressed in "Kilowatt Hours" (or kWh) and is what the power company generally uses to calculate your bill. A kilowatt-hour (kWh) is 1,000 watts used for one hour. As an example, a 100-watt light bulb operating for ten hours would use one kilowatt-hour.

Power factor:

Power factor is defined as the ratio of real power to apparent power. The maximum value it can carry is either 1 or 100(%), which would be obtained in a purely resistive circuit.

$$\text{Power factor} = \text{True power} / \text{Apparent power}$$

- **Apparent power (VA)** is the product of voltage and ampere, i.e., VA or kVA is known as apparent power. Apparent power is total power supplied to a circuit inclusive of the true and reactive power.
- **Real power or true power** is the power that can be converted into work and is measured in watts.
- **Reactive power:** If the circuit is of an inductive or capacitive type, then the reactive component consumes power and cannot be converted into work. This is known as reactive power and is denoted by the unit VAR.

Relationship between powers:

- Apparent power (VA) = $V \times A$
- True power (Watts) = $VA \times \cos\phi$
- Reactive power (VAR) = $VA \times \sin\phi$

Power factor of a circuit is a number that can range from zero to one and it only occurs in an alternating current circuit. Inductance or capacitance in a circuit can cause the voltage sine wave and the current sine wave to not be lined up so they do not reach a peak or zero at exactly the same time. When that happens, the power factor drops below one. The more out of alignment the current and voltage become, the lower will be the power factor of the circuit. Electric motors have high inductance and, therefore, they generally have a power factor that is less than 1.0. For an incandescent light bulb or a resistance type electric heater the voltage and current will be in alignment and the power factor will be 1.0. That is why the current drawn by a light bulb can be simply determined by dividing the wattage by the voltage.

In the case of a 3-phase circuit, there are three conductors supplying the load rather than only two wires as in the case of a single-phase load. The current in one conductor supplying the 3-phase load is 120E shifted in phase from the current flowing in each of the other wires. A factor that takes all of this into account is the number 1.73 which is the square root of three. You can see by comparing the previous two formulas that if the power, voltage, and power factor are the same, less current will be flowing to a three-phase load as to a single-phase load of the same wattage.

POWER SUPPLY

Single Phase Power:

Single Phase power refers to two wire power circuits with one power conductor and one neutral conductor. Most residential homes are fed with single-phase power. The power company runs three wires into the home which comprises of two hot wires and a neutral wire. The neutral is actually a center-tapped feed off the transformer. Voltage measured across both hot wires is 240 VAC and the voltage measured from any hot to neutral is 120 VAC (split-phase). Some people mistakenly believe that a 240 VAC circuit is "two-phase," but they are wrong; it's actually the full phase of a single-phase circuit whereas the 120 VAC feeds are half-phase (split-phase).

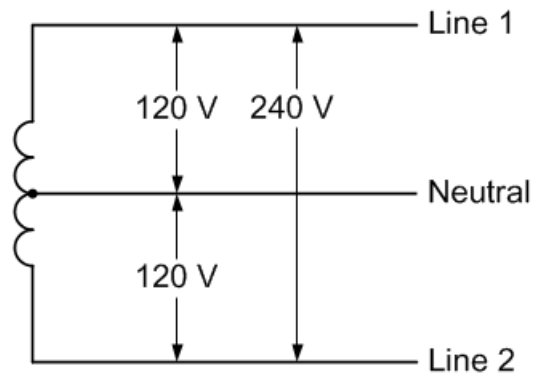

Single Phase Three Wire

The selling feature of 240-volt power is that it's twice as powerful and twice as efficient as 120 volts (allows you to run higher –wattage appliances at half the amperes).

- Line 1 to neutral and Line 2 to neutral are used to power 120 volt lighting and plug loads.
- Line 1 to Line 2 is used to power 240 volt single phase loads such as a water heater, electric range, or air conditioner.

3 - Phase Power:

Three Phase power has three power conductors (120V, 120V, 120V) out of phase with one another and one neutral conductor. For our purposes let's consider a 3 Phase 4 Wire 208Y/120V power circuit. This arrangement provides (3) 120V single phase power circuits and / or (1) 208V three phase power circuit.

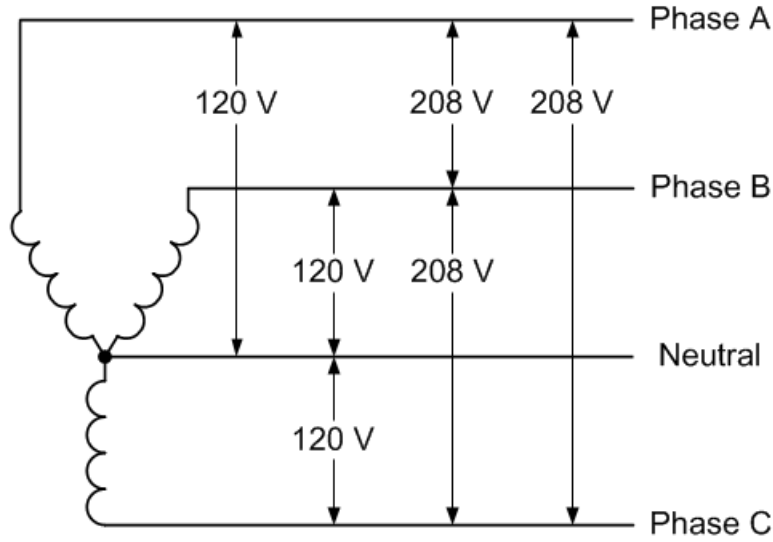

Three Phase Four Wire Wye

The most common commercial building electric service in North America is 120/208 volt wye, which is used to power 120 volt plug loads, lighting, and smaller HVAC systems.

In larger facilities the voltage is 277/480 volt and used to power larger HVAC loads.

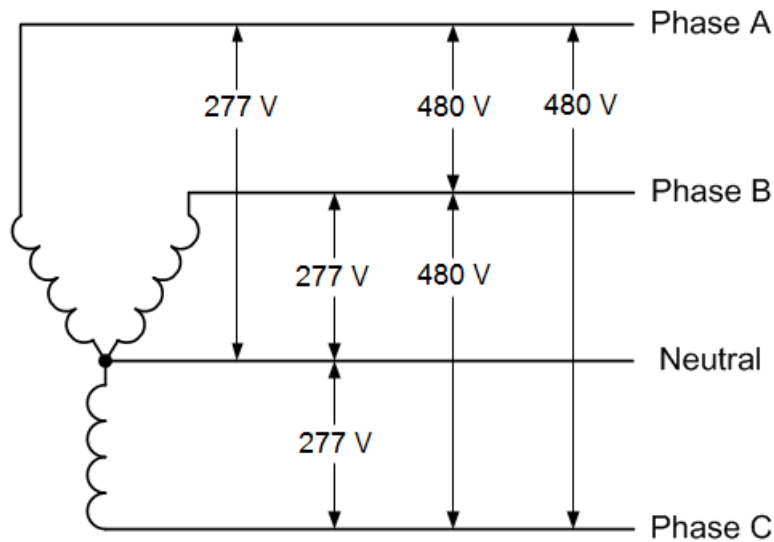

Three Phase Four Wire Wye

Three Phase Three Wire Delta

Used primarily in industrial facilities, 3-wire delta configuration is used to provide power for three-phase motor loads, and in utility power distribution applications. Nominal service voltages of 240, 400, 480, 600, and higher are typical.

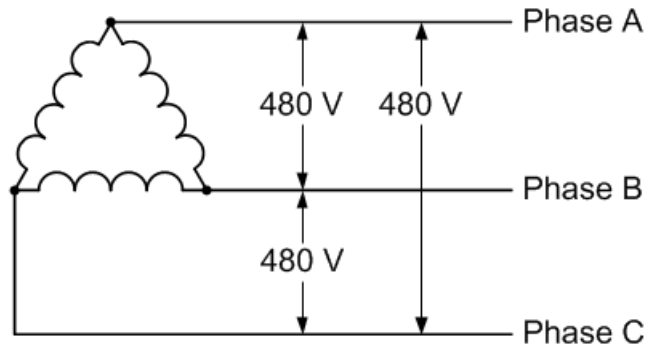

Three Phase Three Wire Delta

CONDUCTORS

The general term “conductor” applies to anything that permits, or conducts, the flow of electricity. Electricity flows in the path of least resistance, and certain materials allow energy to flow more freely than others. Copper, for example, is a good conductor, although aluminum and copper-clad aluminum wires are also used. Insulators are materials that hold back the flow of electric current. Wood and plastic are good insulators.

Electric wires:

Electrical wires are conductors that are sized in two different systems: the American Wire Gauge System (AWG) and the Thousand Circular Mill system (KCMIL), which was known until recently as (MCM). Both systems designate wire size based on their diameter or cross sectional area. The American Wire Gauge system is used to refer to relatively small wires.

AWG sizes: 16gauge to 0000 (4/0). Size increases as number decreases

- 16 gauge smallest = .05”
- 4/0 largest = .46”
- 14 gauge copper wire is the minimum gauge allowed in construction
- MCM: cable larger than 4/0. Sizes are 250, 300, 400, 500 (measurement representing square of cable diameter in thousandths of an inch)

Ampacity:

The current carrying capacity of a particular wire is dictated by its "ampacity" - how many amps it can handle. Ampacity is a function of the cross section area or diameter of the wire and its material type. Larger diameter wires have larger cross section areas and can safely carry more electrical current without overheating. The maximum ampacity for different types of wires is reported in the electrical codes and standards and tabulated based on the size of the wire, temperature application and the insulation type for the particular wire.

Materials:

Basic conductors: copper and aluminum

- Aluminum must be larger to carry same amperage but are lighter and have lower installation cost
- Copper: cost effective in small and medium sized wires
- Aluminum: require special installation b/c joints loosen and oxides form causing resistance and overheating

Conductor Resistance:

The resistance of a conductor depends upon the type of material. For example, copper is a better conductor than aluminum, therefore, the resistance of an aluminum wire is higher than the resistance of a copper wire of the same size and length.

Wire resistance increases as the temperature increases, and decreases as the temperature decreases. As a rough approximation, the resistance of a wire will change about 8% for every 25°C change in conductor temperature.

The resistance of a wire is proportional to the length of the wire.

The resistance of a wire decreases as the cross-sectional area of the wire increases. For example a size 10 AWG wire has about four times the cross-sectional area of a size 16 AWG wire.

PART - 2**ELEMENTS OF POWER DISTRIBUTION**

As electrical energy is generated, it is transformed and transported instantaneously through a network of wires, substations, and transformers to the consumer. Electricity is generated at a comparatively low voltage 6.6 kV, 11 kV or 33 kV (r.m.s.) depending on the design of generator and is stepped up via step up transformers to values as high as 69 kV to 132 kV or higher before it is fed into the transmission lines. The cables themselves are usually made of aluminum (low resistivity) on a steel core (strength) and are supported by means of strings of ceramic insulators on steel pylons. This network of transmission lines and pylons forms the Grid System.

To supply the power needs of a particular region this voltage will be stepped-down at a Sub-Station to the required voltage. This voltage may then be further reduced by smaller Sub-Station Transformers. A Tertiary Grid System (Voltage at this point is 11 kV) has many branches feeding small local Sub-Station Transformers where the voltage is finally reduced to 480/240V levels.

From the generating station to the final destination, the energy from generated electricity undergoes numerous changes in voltage and direction. Each change requires expert design and handling to provide the consumer with the least expensive, most reliable energy they can buy.

Substation, Switchyard, Switchgear:

- Substation is place where high voltage is stepped down via step-down transformers. Most substations include one or more transformers and switchgear to control the flow of electricity into and out of the substation. When we define substation, we call it 220/33kV, 100MVA substation. Substation can be indoor as well as outdoor.
- Switchyards deliver the generated power from power plant at desired voltage level to the nearest grid. When we define switchyard, we call it 220kV switchyard, 33kV switchyard. Switchyards are generally in open yards. A large fence is generally used to keep the public out of switchyards and open substations since high voltage electricity is dangerous.
- Switchgear is a combination of switching devices such as electrical disconnects fuses and/or circuit breakers, relays and other electrical controls used for control, metering (measurement) and switching. Switchgear is used both to de-energize equipment to allow work to be done and to clear faults downstream.

Power Distribution:

For reasons of economy and efficiency, it is preferable to transmit electricity at High Voltage. The power generated $P = V \times I$ (Watts).

However, certain losses occur during the conducting process which amount to: $I^2 \times R$ (Watts).

Power Available = $(V \times I) - (I^2 \times R)$ (Watts)

These losses must therefore be kept as small as possible.

This means that either I or R must be kept small.

To keep R small metal with Low Resistivity (Copper or Aluminum) could be used in cables with Large Diameter but a thick cable over long distances would be very expensive.

It is preferable therefore to reduce "current, I".

This can be done but to maintain the same power output; the voltage must be increased. To do this a Transformer is used.

Transformers:

The transformer is the heart of the substation. The transformer changes the relationship between the incoming voltage and current and the outgoing voltage and current. It consists of two separate coils of wire wound around a laminated steel core. When an alternating current is passed through one coil of wire the current flow creates a magnetic field around the coil. The second coil of wire, usually wound= directly over the first coil, is within the magnetic field created by the current in the first coil. Because the current in the first coil is alternating back and forth, the magnetic field will be in constant motion. The moving magnetic field induces a current flow in the second coil of wire. The relationship between the voltage of the first coil and the voltage of the second coil is directly proportional to the number of turns of wire on the first coil as compared to the number of turns of wire on the second coil. If the first coil (called the primary winding) has twice as many turns as the second coil (called the secondary winding) then the voltage of the secondary winding will be only half that of the primary winding. This is also called the "Turns Ratio".

Cold rolled grain oriented (CRGO) steel is used as the core material to provide a low reluctance, low loss flux path. The steel is in the form of varnished laminations to reduce eddy current flow and losses on account of this.

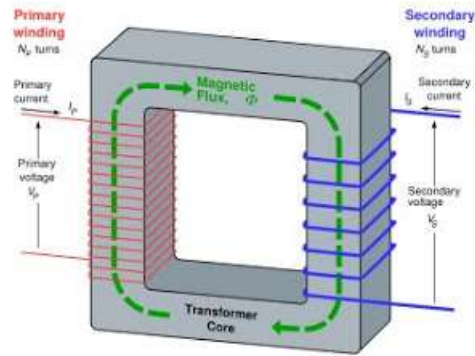

There is a very simple and straight relationship between the potential across the primary coil and the potential induced in the secondary coil. The ratio of the primary potential to the secondary potential is the ratio of the number of turns in each and is represented as follows:

$$N1/N2 = V1/V2$$

Where

- N1 = Number of turns in primary
- N2 = Number of turns in secondary
- V1 = Voltage in primary
- V2 = Voltage in secondary

Another important fundamental principle of transformers is that when the transformer is loaded, then the current is inversely proportional to the voltages and is represented as follows:

$$N1/N2 = V1/V2 = I2/I1$$

- N1 = Number of turns in primary
- N2 = Number of turns in secondary
- V1 = Voltage in primary
- V2 = Voltage in secondary
- I1 = Current in primary
- I2 = Current in secondary

In an actual transformer there are some losses due to heating and this does not hold exactly true, but for the purpose of installing transformers and the wiring and overcurrent protection for transformers this relationship is assumed to be true because it represents a worst case

situation. It is important to note in the following formula that if the secondary voltage is only half the primary voltage, the secondary current will need to be double the primary current to keep both sides of the equation equal.

SECONDARY POWER DISTRIBUTION

Electric energy leaves the distribution substation and is distributed on three phase distribution lines to switchboards. The supply or intake cable may enter the building through an underground duct or via an overhead supply. An underground supply is preferred since all of the electrical service is hidden. The supply cable is terminated in the area board's fused sealing chamber which houses an electric meter to record the electricity consumed in units of kilowatt/hours along with peak demand.

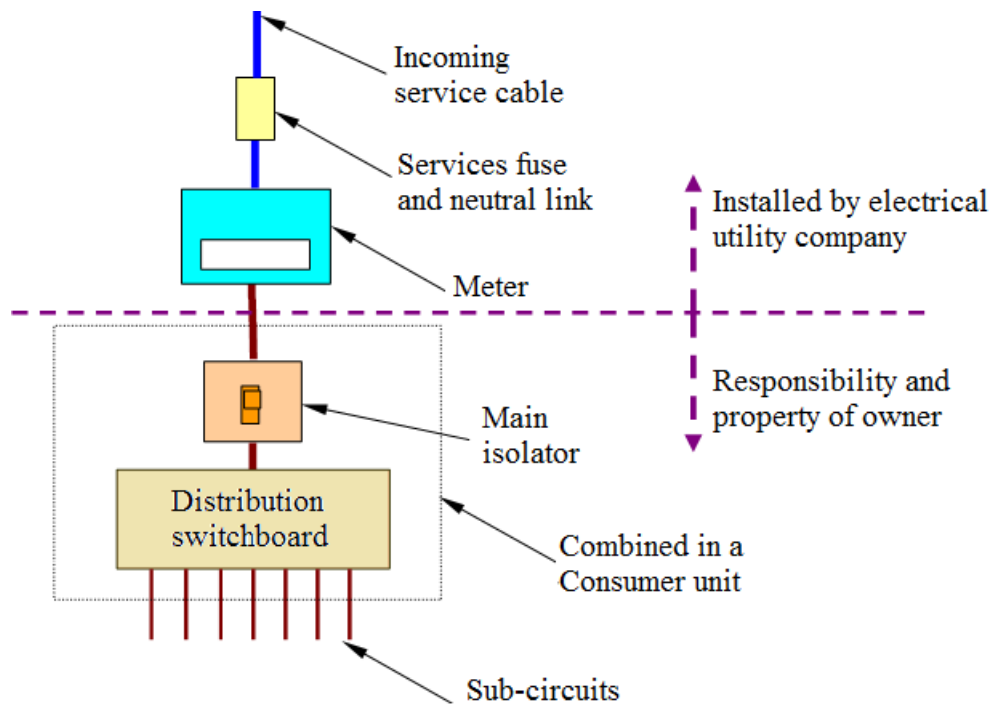

Switchboards take a large block of power and break it down into separate circuits, each of which is controlled and protected by the fuses or switchgear of the switchboard.

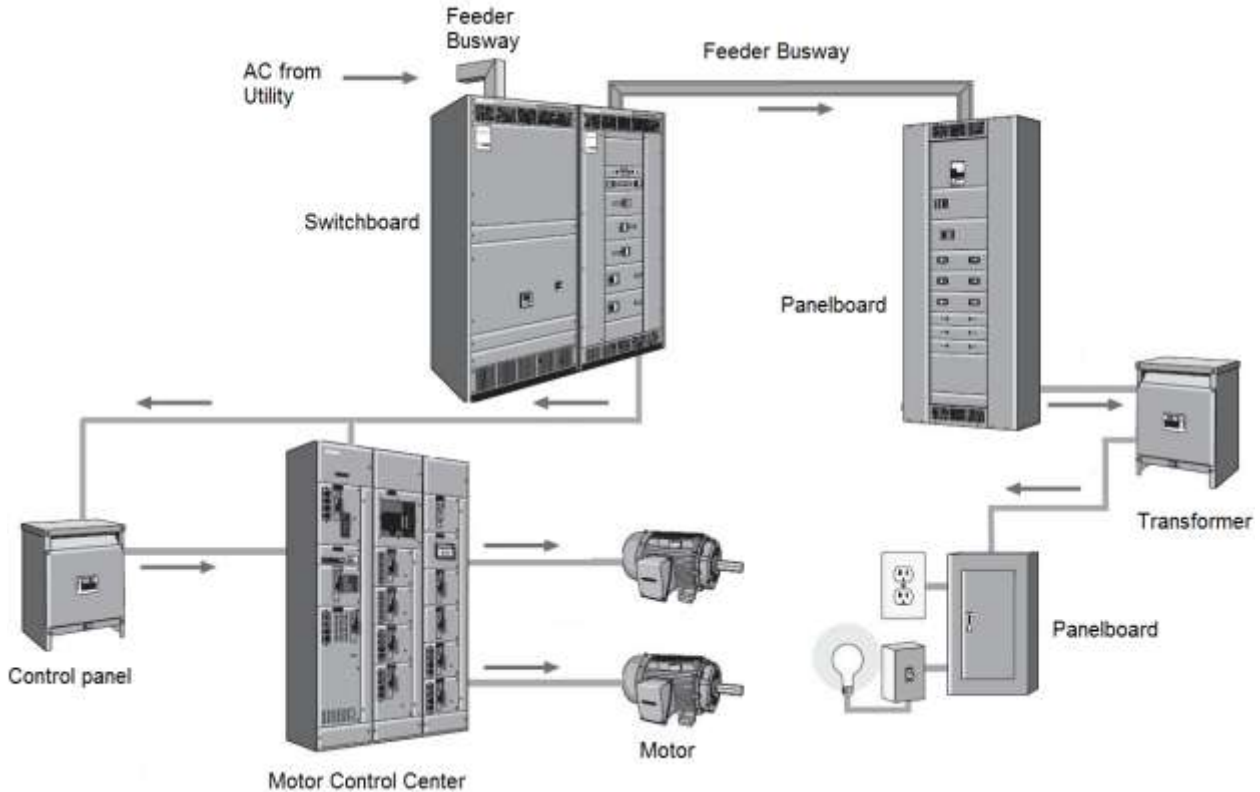

Typical Secondary Power Distribution

Electric Switchboard:

An electric switchboard is a device that directs electricity from one source to another. The role of a switchboard is to divide the main current provided to the switchboard into smaller currents for further distribution and to provide switching, current protection and metering for these various currents. In general, switchboards distribute power to transformers, panelboards, control equipment, and ultimately to system loads, MCC.

Inside the switchboard there is a bank of busbars - flat strips of copper or aluminum, to which the switchgear is connected. These carry large currents through the switchboard, and are supported by insulators. A switchboard may include a metering or control compartment separated from the power distribution conductors.

Panelboard:

A panelboard is an enclosed assembly with circuit breakers, or fused switches, or rarely, fuses, assembled to a bus. Branch circuits feed power to receptacles, switches, fixtures and appliance in different areas of the building.

- A 120 volt circuit consists of one hot conductor and one neutral conductor. The hot conductor originates at the breaker or fuse connected to one of the hot bus bars.
- A 240 volt circuit requires both hot bus conductors, so it originates at a breaker or fuse connected to both hot bus bar.

While panelboards and switchboards both perform power control and circuit protection functions, there are key differences between these systems. A panelboard must be mounted in or against a wall; whereas, some switchboards must be installed away from a wall to allow access to the rear of the unit for installation and maintenance purposes. Perhaps the key difference, however, is the amount of power controlled by each type of system. In general, switchboards can be configured to include larger circuit breakers or switches so that they can handle greater amounts of current. This also means that switchboards may be more complex and can incorporate a broader range of devices.

Motor Control Center (MCC):

A motor control center is a factory assembled grouping of one or more vertical metal cabinet sections with power bus and other switchgear for controlling a group of motor feeders. Each section may contain compartmentalized starters, feeders, transformers, adjustable frequency drives and panelboards just to mention a few. Depending upon the size, most starters and feeders may be plug in type. These units are typically rated up to 600 volts AC.

They are modular in design, compartmentalized, fixed or draw-out type suitable for indoor or outdoor installations. Motor control centers provide wire ways for field control and power cables and can be specified with a range of options such as separate control transformers, pilot lamps, control switches, extra control terminal blocks, various types of bi-metal and solid-state overload protection relays, or various classes of power fuses or types of circuit breakers.



A Typical Motor Control Center

A motor control center can either be supplied ready for the customer to connect all field wiring, or can be an engineered assembly with internal control and interlocking wiring to a central control terminal panel board or programmable controller. The enclosure of MCC is classified according to its capability of withstanding the entry of solid particles such as dust, vermin and liquids such as water, oil etc.

NEMA rated motor control centers are usually the standard in the USA, Canada and most of Mexico. IEC rated motor control centers are usually found in Europe, Asia, Australia and Brazil. The standards provide the description of enclosure rating, busbar, short circuit & seismic rating, wire class drawings

Control Panel:

Control panel consist of a controller. Controller may be PLC, DCS, relay or some other type. It gives digital signal input signal to the MCC panel to start the motor. Control panel works based on the PLC /DCS program or the relay logic. Instruments are normally connected to control panel. Indications for the interlocks also will be there in control panel. Nowadays single panel is used of using separate control and MCC panel.

Bus Bars:

Busbars are conductors that serve as a common connection for two or more circuits. The secondary of the transformer is typically suspended from the ground on insulators connected to rigid metallic bar, which is then tapped at several points to supply power for the distribution feeders. Engineers refer to such an energized bar as "busbar" or simply "bus." Busbar is used in place of wire due to its rigidity and larger current carrying capacity. The material used for

busbars is E91 E grade aluminum or electrolytic grade copper. The precautions that are to be taken while selecting and mounting busbars are:

- Busbars are sized considering system fault current and for specified load current with respect to ambient temperature and final working temperature.
- Busbars should be insulated and properly supported with adequate clearances between phases-neutral-earth.
- For MCC, the main bus should be rated to carry 125% of the largest motor running in addition 100% of the full load rating of all the other motors operated at the same time. Allowances should take into account motor duty cycle and demand factor. Allowances should be made toward future loads.

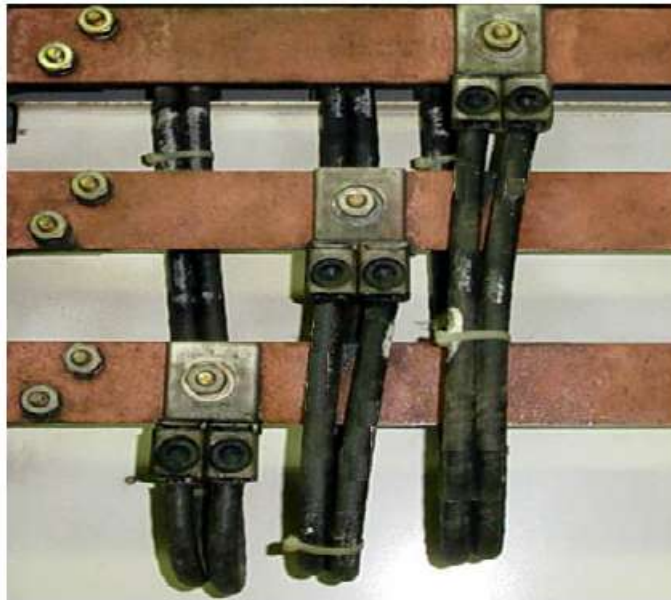

BusBars

Building Electrical Distribution System:

A single line diagram (SLD) is commonly used to analyze a building's electrical system and it depicts all the components and distinguishable features of an electric circuit.

A single line diagram (SLD) is circuit diagram where "one-line" is shown to represent three phases of a three phase power system. In addition to showing the ratings and size of electrical equipment and circuit conductors, a properly drawn one-line diagram also shows an electrically correct distribution of power with respect to current flow from the power source to the downstream loads or panel boards. Electrical elements such as circuit breakers,

transformers, capacitors, bus bars, and conductors are shown by standardized schematic symbols. Elements on the diagram do not represent the physical size or location of the electrical equipment. You can read the single line diagram from the top to the bottom or from left to right of the diagram.

An example below illustrates the concept.

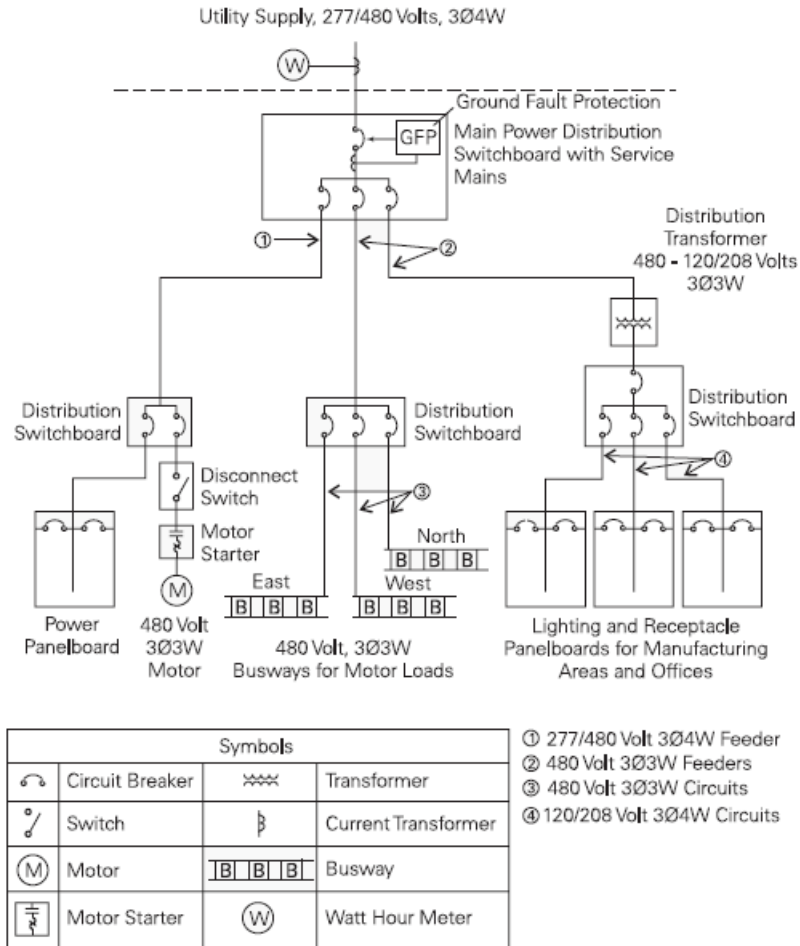

The diagram shows that power from the utility company is metered and enters the facility through a distribution switchboard. The switchboard serves as the main disconnecting means that serves three separate distribution boards.

1. The feeder on the left feeds a distribution switchboard, which in turn feeds a panel board and a 480V, three-phase, three-wire (3Ø3W) motor.
2. The middle feeder feeds another switchboard, which divides the power into three, three-phase, three-wire circuits. Each circuit feeds a busway run to 480 volt motors.

3. The feeder on the right supplies 120/208 volt power, through a step-down transformer, to lighting and receptacle panel boards. Branch circuits from the lighting and receptacle panel boards supply power for lighting and outlets throughout the plant. In many cases busway can be used in lieu of the cable/conduit feeders at a lower cost.

Importance of Single Line Diagrams:

It offers several benefits to the facility.

On one-line power diagrams, components are usually arranged in order of decreasing voltage levels. The highest voltage component is shown at the top right of the drawing. Building maintenance staff and electricians rely on one-line diagrams to show them the way around the electrical system. In order to find out how power is supplied to a component, start at the component and trace the flow of power backwards through the drawing. This method will be most useful in locating the correct circuit breaker to isolate a component for maintenance.

Facility supervisors may use the info found in single-line diagrams to greatly enhance the performance of service activities.

ELECTRICAL PROTECTION & CONTROL

Circuits are controlled by switchgear, which is assembled so that the circuit may be operated safely under normal conditions, isolated automatically under fault conditions, or isolated manually for safe maintenance. These requirements are met by good workmanship and the installation of proper materials such as:

1. Circuit breakers
2. Fuse
3. Disconnect switches or isolators
4. Capacitors
5. Relays
6. Contractors
7. Starters

PROTECTION AGAINST OVERCURRENT

The amperage (current flow) in any wire or conductor is limited to the maximum permitted by design. Over current protection is installed to provide automatic means for interrupting or

opening a circuit in even of load currents above their rating and from fault or short circuit. Two types of over current devices are in common use, circuit breakers and fuses, both rated in amperes.

Circuit breakers:

Circuit Breaker is a generic term whose meaning is implied in its name, something that breaks a circuit. Circuit breaker is a switching device capable of protecting the distribution line or feeder connected to it from overloads and faults. If a circuit overload, the mechanism inside the breaker trips the switch and breaks the circuit. The circuit breaker may be reset by simply flipping the switch. A circuit breaker is capable of taking harmless short period overloads (such as the heavy initial current required in the starting of a motor of say fan motor) without tripping but protected against prolonged overloads. After the cause of trouble has been located and corrected, the power is easily restored by flipping the circuit breaker.

Since a circuit breaker is designed to make as well as break a large amount of power, it is widely used to protect an entire electrical installation, against a massive short circuit current or current drawn in excess of its rated capacity.



Circuit Breaker

Fuses:

A fuse is a device used for protecting the switchgear equipment and cables against over currents. When a fuse element blows, the circuit breaks and as a consequence an arc is established between the breaking points, thereby generating a large amount of heat which can damage adjacent equipment and set fire to wires and cables. In order to prevent this, fuse elements are housed in a strong and non-inflammable body (generally ceramic) filled with quartz and so that when the fuse element blows, the sand automatically falls down and covers

the live contact, thereby quenching they are. This type of fuse can quench known as a High Rupturing Capacity fuse (HRC fuse).

The High Rupturing Capacity type fuse has a great advantage in that it starts blowing much before the entire short circuit current passes through the fuse element. Thus, an HRC fuse is the fastest acting device to give protection to equipment under short circuit condition.

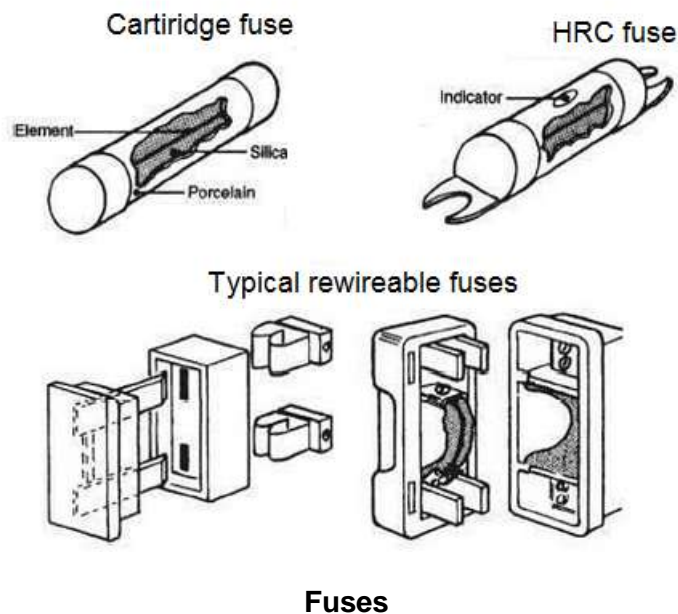

Isolators and Switches:

An isolator is a mechanical device, which is opened manually and is provided so that the whole of the installation, one circuit or one piece of equipment may be cut off from the live supply. In addition, a means of switching off for maintenance or emergency switching must also be provided. A switch may provide the means of isolation but an isolator differs from a switch in that it is intended to be opened when the circuit concerned is not carrying current. Its purpose is to ensure the safety of those working on the circuit by making dead those parts, which are live in normal service.

Note: An Isolator can merely establish the circuit, that too under no load. It cannot establish or break any load current, whereas a switch can make or break an electrical circuit under rated load current. One device may provide both isolation and switching provided that the characteristics of the device meet the Regulations for both functions.



Disconnecting Switch

Oil Cutout (Oil-Filled Cutout):

A cutout in which all or part of the fuse support and its fuse link or disconnecting blade is mounted in oil with complete immersion of the contacts and the fusible portion of the conducting element (fuse link) so that arc interruption by severing of the fuse link or by opening of the contacts will occur under oil.



Oil Cutout

Ground fault interrupter (GFI):

A device that detects small current leaks and disconnects hot wire to the circuit. Can be part of circuit breaker.

Capacitors:

Capacitors help adjust the power factor and voltage and allow electricity to be distributed more efficiently. They can be remotely controlled and switched into and out of the system as needed. Some capacitor banks are controlled with temperature switches so that if the temperature exceeds a certain value, the capacitor bank is automatically switched into the circuit. Others are set on time clock switches to automatically be connected and disconnected to the system during pre-determined times typically corresponding to operation of a large factory or some other load with a low power factor.

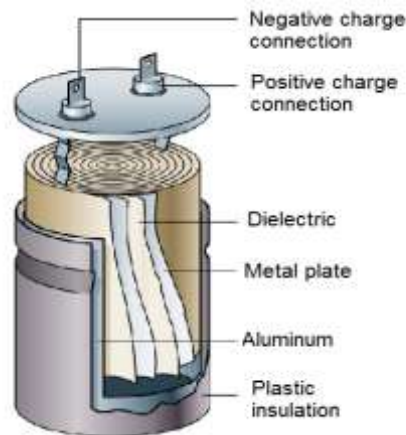

Capacitor

Relays:

Relays are small very fast acting automatic switches designed to protect an electrical system from faults and overloads. It is usually electromagnetic device which has coil. When this coil is supplied with power, a magnetic field created and will operate mechanical switch. When a relay senses a problem it quickly sends a signal to one or many circuit breakers to open, or trip, thus protecting it as well as human life from damage or injury. Relays can also be activated using communication lines to open or close circuit breakers on command.



Electromagnetic Relay

The commonly used protective relays in HVAC systems are:

Overload/overcurrent relay (thermal and magnetic), single phasing preventing relay, phase reversal relay, short circuit Protection relay, earth fault relay, thermistor relay, special motor protection relay (for protection of higher HP rated motors).

Contactors:

A contactor is an electrically operated switch that can be made to switch on or switch off a motor, a heater bank, capacitor bank etc. directly or by a remote controller such as thermostat, humidistat, timer, pilot devices or any protective devices. It consists of 2 or 3 or 4 power contacts and some auxiliary contacts.



Contactor

Although a switch, a contactor is designed to interrupt (making & breaking) electric current repeatedly and frequently, due to the simplicity of its mechanism and contact design. When a contactor breaks the current, an arc is established across the contacts where the circuit is broken and a good amount of heat energy is generated. This increases when the frequency of breaking the current increases resulting into welding of contacts or fusing and contactor failure.

Motor Starters:

Starter is a device which connects with motor in series to limit the inrush current at start and establish a starting torque to get the motor to its rated load speed. A starter consists of:

1. A magnetic contactor
2. A disconnect device: fuse or circuit breaker to protect motor from drawing excess current under sustained overload conditions.
3. An overload relay which may be bi-metallic, melting alloy or solid state.
4. A control circuit consisting of pilot devices, relays, timers, PLC's.

It may also include step resistors, disconnects, reactors, auto-transformers or other hardware to make a more sophisticated starter for large motors.



Motor Starter

A motor starter is designed to provide one or more of the following functions.

- Start, accelerate and stop a motor repeatedly, quickly, safely and dependably.

- Protect motor against operational overloads.
- Disconnect supply to motor in case of under-voltage/no voltage, if there is danger to operator or to the machinery due to automatic restarting of motor on restoration of full/balanced voltage.

The starter can also perform the following functions with suitable additional devices.

- Protect motor against severe unbalance in voltage and current.
- Limit inrush/starting current wherever called for.
- Protect starter components/installation from short circuit fault.
- Provide remote operation facility.

Type of Starters:

Starters are divided into two types:

1. Full voltage or across-the-line or direct on line (DOL) starters where the motor load is directly applied to the line voltage.
2. Reduced voltage or assisted type starter. Where the motors load is initially applied to a reduced voltage and later to the line voltage. The following reduced voltage starters are commonly used in ACR Systems:

- Star delta starter
- Auto transformer starter
- Part winding starter
- Soft starter and variable frequency drive

Commonly used starters in HVAC systems

1. **Direct Online Starter:** DOL starters have the lowest initial cost and since full voltage is applied the motor produces maximum starting torque and the load accelerates fast. Since the motor draws a high starting current to the extent of 600% to 800% of its full load current, larger HP motors will cause a severe dip in the supply system voltage.
2. **Star Delta Starter:** In this starter, one end of the motor windings is initially shorted together and supply is fed to the other end of the motor windings. Thus even though full voltage is applied to the motor terminals, the effective voltage applied to the

windings becomes only 1/3 i.e., 57.7% of the rated voltage. After a preset time, the shorting done at one end of the winding is removed and motor receives full voltage. The reduced supply voltage restricts motor starting current to $(0.577)^2$ i.e., 1/3rd or 33% of full load starting current. Starting is in two steps, hence jerk is minimized.

As the voltage applied in each phase is reduced by 1/3 the torque is reduced by $(1/3)^2$ and hence this starter cannot be used where load requires a high starting torque. The time taken for the motor to accelerate is longer due to reduced voltage input. If timing of changeover from star to delta is not set properly the motor is on full line voltage prematurely and will draw a heavy current thereby defeating the main purpose of restricting the starting current. Closed transition is possible only by adding additional resistor or reactance, timer and power contactor hence this type becomes further expensive. (In a closed transition the current is not broken when the change over from star to delta takes place, whereas, in an open transition, not only the current is broken when the changeover takes place from star to delta, but also the motor gets a heavy kick/jerk when full voltage is applied).

- 3. Auto Transformer:** It is basically a reduced voltage starter in which an auto transformer is used to supply reduced voltage to the motor windings initially. At start, supply from mains is fed to the motor windings through one of the taps on the auto transformer. This reduced supply voltage caused the motor to draw much lower current as compared to the current drawn by a DOL starter. Once the motor reaches almost the rated speed, the auto transformer is disconnected from the circuit and full supply voltage is fed directly to the motor. Thus the motor draws full load current and produces full load torque.

An auto transformer is generally provided with 3 tappings of 50% or 57.7% 65% and 80% voltages. The corresponding starting current and torque at these voltages are:

Taps at	Starting Current	Starting Torque
50%	25%	25%
57.7%	33%	33%

65%	42%	42%
80%	64%	64%

This type has an advantage of reduction in starting current and torque. Being a two-step starter, starting jerk is minimized compared to DOL. With a minimum of 3 voltage tapping's available in an auto transformer, by selecting appropriate voltage taps, the starter becomes flexible to obtain different starting torque at site to match different load conditions. Closed transition is possible. Having more costly components like auto transformer, contactors, timer etc. It is much more expensive compared to DOL or star delta starter. It is larger in dimensions than DOL or star delta starter. If the timer for changeover from auto transformer to full supply voltage is not set properly, the motor will changeover to full supply much earlier and it will function as a DOL starter and draw much higher starting current thereby defeating the basic purpose of current reduction.

- 4. Part Winding Starter:** This is one of the simplest types of reduced voltage starter used to control the inrush current of motor. The poly phase motor has basically two parallel windings, both wound on the same poles. One set of each winding leads are brought out to the terminals and the other set of windings leads are shorted either internally or externally.

As the windings are in two parts, the power supply is initially fed to one of the windings, thus the motor draws a low starting current, The power to the second winding is fed after a set time and the motor then draws full load current.

Motors in either 67% / 33% or 50% / 50% windings can be selected depending upon the starting torque requirement.

It is less expensive than ATS or star delta starters. Closed circuit transition is possible. Starting torque is better than star delta. Small sized fuses are adequate compared to Dol. Inrush current is restricted to a maximum of 65% of starting current depending upon the time the second winding is energized. It can withstand better voltage fluctuations.

Limitation in motor selection and starting torque is restricted to a maximum of 45 percent of rated torque of motor.

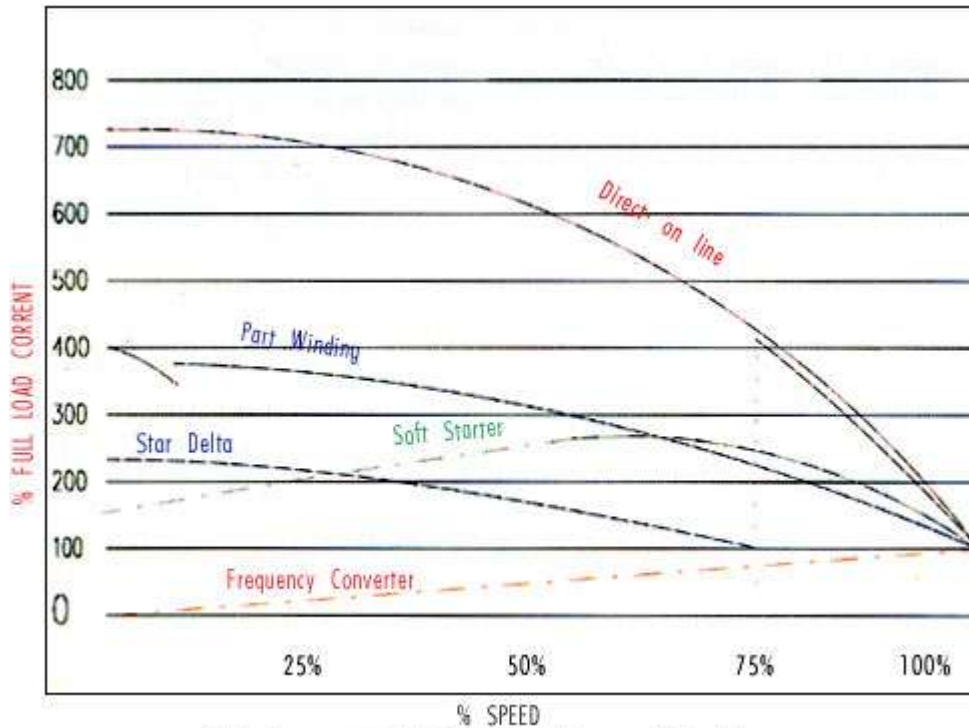

Starting current of various types of starters

5. **Soft Start:** A Soft Start describes a type of motor control that includes a simple solid state power controller. Instead of simply opening and closing the power circuit like a 3 Phase motor contactor, it ramps the motor voltage up or down to turn the motor on and off. A Soft Start is more expensive than other types of motor starters, but provides the added benefit of reducing electrical and mechanical shocks associated with starting and stopping a motor.

6. **Variable Frequency Drive:** A Variable Frequency Drive (VFD) describes a type of motor control that includes an advanced solid state power controller. Instead of simply opening and closing the power circuit like a 3 Phase motor contactor, or ramping the motor voltage up or down like a soft start, to turn the motor on and off, a Variable Frequency Drive (VFD) controls motor speed. A Variable Frequency Drive (VFD) is more expensive than Soft Start, but provides the added benefit of controlling motor speed.

Control Devices:

A control device is a mechanical, electrical, electronic or thermal switch which serves the purpose of switching on or switching off a circuit breaker, motor starter, heater & capacitor bank. These also include signaling, electric interlocking etc.

There are two types of control devices i.e., manually operated and automatically controlled.

Manually operated control devices are: push buttons & selector switches. Automatic control devices are: Pressure switches, float switches, flow switches, thermostats, thermistor relays, limit switches, protective relays, timers and auxiliary contactors.

All manually operated devices are actuated manually whereas automatic control devices are actuated in response to specified conditions of a requirement.

Bear in mind that control devices can switch on only small current loads like electromagnetic coil of a contactor or small pilot motors in motorized valves and fire dampers or indicating lamps. They cannot be used to interrupt power circuits directly since these carry large currents which can cause immediate failure of the control device.

PROTECTION AGAINST ELECTRIC SHOCK

What causes shock?

Current flows in a continuous closed path from the source, through a device that uses the power and back to the source. But electricity need not flow in wires to make the return trip to the source. It can return through any conducting body including a person that contacts the earth directly or touches a conductive object that in turn enters the earth. And if you accidentally become a link in an electrically live circuit, you'll get a shock. For example, if the hot wire accidentally became dislodged from a light fixture terminal and came into contact with the light fixture's metal canopy, which is highly conductive, the fixture would become charged. If you touch the fixture under these conditions, a current leakage, or ground fault could occur in which you would provide the path to ground for electric current, and you would get a shock.

Protection against electric shock is provided by insulating and placing live parts out of reach in suitable enclosures, grounding and bonding metal work and providing fuses or circuit breakers so that the supply is automatically disconnected under fault conditions.

Grounding (Earthing):

This shock can be prevented, if the circuit had a grounding system. Grounding is achieved when one of the conductive wires serving as part of the circuit path is intentionally given a direct path to the earth, which by virtue of moisture contained within the soil, serves as an effective conductor.

Grounding achieves three important objectives:

- It limits the voltage upon the circuit that might otherwise occur through exposure to lightning or other voltages higher than that for which the circuit is designed.
- It limits the maximum voltage to ground under normal operating conditions.
- It provides automatic opening procedure of the circuit if an accidental or fault ground occurs on one of its ungrounded conductors.

Grounding is commonly accomplished by connecting one of the circuit wires (typically neutral) to the soil or ground by running a wire to a ground rod, a long copper rod driven directly into the soil. Grounding assures that all metal parts of a circuit that you might come in contact with are connected directly to the earth, maintaining them at zero voltage. During normal operation, a grounding system does nothing; in the event of a malfunction, however, the grounding protects from electric shock or fire.

Note: Electrical codes require that all circuits 120 volts and above have a system of grounding. “Grounding” is American standard term is equivalent to “Earthing” which is IEC standard term.

There are several advantages to the induction motor: no brushes or commutator means easier manufacture, no wear, no sparks, no ozone production and none of the energy loss associated with them.

Speed of rotation: synchronous speed

The synchronous speed of a motor can be determined by the formula:

$$\text{Synchronous speed} = \frac{120 \times f}{\text{No. of poles}}$$

Where:

- speed is expressed in rpm (revolutions per minute)
- f equals frequency in Hz (hertz)
- poles is an even number, i.e. 2,4,6 etc.

The formula for synchronous speed makes it obvious to see that as the frequency varies, the speed varies in a direct proportion, that is, if we double the frequency, the speed doubles.

We call the hypothetical speed 'synchronous' speed because it is the maximum speed that would be obtained if the rotor rotated in 'synchrony' with the magnetic field, that is if the rotor kept up with the rotating magnetic field of the stator.

The ideal speed of rotation is determined by two (2) factors:

1. The number of magnetic poles.
2. The frequency of the AC supply.

It is possible to arrange the stator windings in such formations as to provide any number of pairs of poles and so we can offer 2, 4, 6, 8, 10, 12 pole motors etc. Motors over 12 poles are available if required, but they are not in common use.

The 'slip':

In any AC induction motor the synchronous speed is never achievable, since friction losses in the bearings, air resistance within the motor and additional drag imposed by the load combine to cause the rotor to lag slightly behind the rotational speed of the magnetic field.

This lagging effect is known as the slip.

The percentage slip varies from one motor to the next as a general rule of thumb, the larger the motor, the less slip is experienced.

For any given motor the slip will decrease as the load decreases. At no load, the slip may be as little as 0.5%, whilst at full load, depending on the size of the motor, it can be high as 5.0%.

Actual speed:

The actual speed is determined by both:

- the slip
- the loading of the motor

It is not surprising to find that the slip of a motor is closely related to the motor's efficiency and, in fact, the full load speed of a motor is a good guide to the motor's efficiency.

Motor Efficiency

We all know that to get a motor to do work we need to supply a source of electrical power. In an ideal world ALL of the power that is put in would be seen at the output.

However, all real systems have losses:

Power losses in induction motors can be grouped into two main components. These are:

Fixed losses, i.e. independent of motor load:

- Iron or magnetic loss in the stator and rotor cores
- Friction and windage loss.

Losses proportional to the motor load:

- Resistive (I^2R) or copper loss in the stator and rotor conductors,
- Stray loss caused by components of stray flux

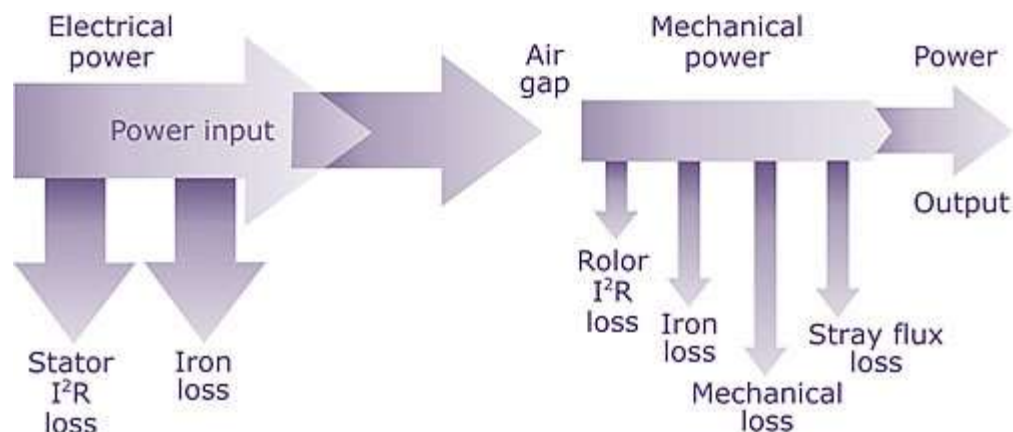

Defining Efficiency:

Efficiency is the percentage of the power input that reaches the load:

$$\eta = \frac{P_{out}}{P_{in}}$$

Where:

- η is a decimal value; if multiplied by 100 will give the efficiency as a percentage
- P_{out} is the output power
- P_{in} is the input power.

The efficiency rating of an induction motor accounts for the losses in both the stator and the rotor.

- In the *ideal world* an electric motor would be 100% efficient.
- In the *real world* it is more realistic to expect 50% efficiency.
- Low efficiency means higher running costs.
- Not all electric motors are created equal. Some are more efficient than others

Motor Sizing

Motors are most efficient when they are optimally loaded. A significant reduction in efficiency occurs at loads of 25% full load or less, and it is at this level that serious consideration should be given to fitting a smaller motor.

It is important to remember that it the load that determines how much power the motor draws. The size of the motor does not necessarily relate to the power being drawn. For example, a fan requiring 15 kW could be driven by 15 kW motor – in this case it is well matched. It could also be driven by a 55 kW motor, and although it would work, it would not be very efficient. However connecting it to a 10 kW motor would soon cause motor to trip out. This shows the importance of knowing the actual power drawn by the motor.

High efficiency motor (HEM)

A typical 10kW high efficiency motor might have the following specifications.

- A high efficiency motor (HEM) will have an efficiency of 93%. Standard electric motors have an efficiency of 88%
- Provides a saving of 4.3% in both energy and greenhouse gas emissions

- Recoup the premium paid for a HEM in less than two years

The gap between standard and high efficiency motors becomes increasingly wide as motor size decreases. Many small motors, such as those used in exhaust fans, may have efficiencies as low as 50%.

Figure below shows the variation in efficiency with load for a standard and higher efficiency 7.5 kW motor.

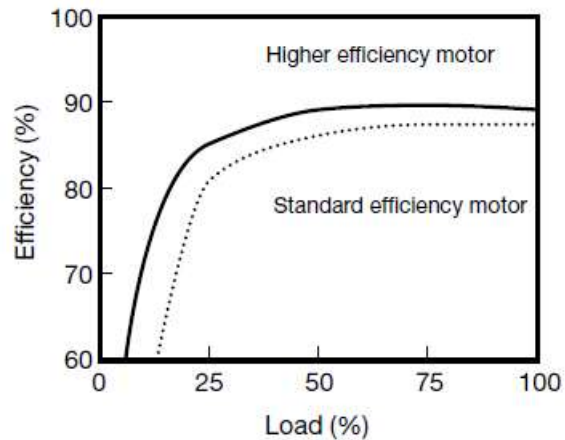

Several factors combine to make a motor energy efficient:

- higher quality low loss laminations for magnetic circuit
- more and better quality copper in the windings
- better quality insulation
- optimized air gap between the rotor and stator
- reduced fan losses
- closer matching tolerances
- Greater core length.

The motor nameplate and motor efficiency tables

All motors have a metal nameplate fixed to their body. The nameplate gives a number of the motors characteristics including:

- Brand

- kW or hp (horse power)
- Hz (frequency)
- Amps
- Ambient temperature
- Efficiency (%)
- Voltage (Star / Delta)
- RPM
- $\cos \phi$ (power factor)

ABC								
3" Motor M3AA 160 MA 2								
Amb. 40°C Enc. IEC								
No.								
							Ins. cl. A	IP 55
V	Hz	kW	hp	r/min	A	$\cos \phi$		
590	Y	50	11	15	2935	10,8	0,9	
400	Δ	50	11	15	2935	19,2	0,9	
660	Y	50	11	15	2930	11,6	0,91	
380	Δ	50	11	15	2930	20	0,91	
415	Δ	50	11	15	2940	18,7	0,89	
460	Δ	60	11	15	3545	16,8	0,9	
Prod. code ABC 11H3AA290								
EPAct: CC031A		NEMA Nom. Eff. 90,2						
6309-27/C3		6209-27/C3		84 kg				
IEC 60034-1				JG2V 194 001-40				

Example motor nameplate

Rated Motor Power:

The rated motor power is the shaft power, i.e. the useful mechanical power that it can provide to turn the load. But because the motor itself has losses, the power drawn by the motor at full load will be greater than the rated shaft power. For example, at full load, a 30 kW motor that is 92.5% efficient will draw $(30/0.925) \text{ kW} = 32.4 \text{ kW}$.

Motor efficiency calculations:

Example:

A Toshiba 2 pole 11kW motor has an efficiency of 91% at full load. What is its running cost based on 4000 hours a year at 10 cents per kWh?

Calculation:

First, let's calculate the losses

11 kW x 9% (Note: 100% - 91% = 9% = 0.9).

11 kW x 0.09 = 0.99 kW (this is the total of the losses).

Therefore the total power that must be supplied to the motor will be:

11 kWh + .99 kWh = 11.99 kWh (rounded to 12 kWh).

Total power used in the year:

12 kWh x 4000h = 48,000 kWh or 48 MWh.

Total cost of running the motor in ONE year:

12 kWh x 4000h x \$0.10 = \$4,800 a year.

Question:

What would the running costs be for one year if the motor's efficiency was only 81%?

11 kWh x 0.19 = 2.09 kWh (losses: 100% - 81% = 19%)

11 kWh + 2.09 kWh = 13.09 kWh

Total running cost in ONE year:

13.09 x 4000 x 0.10 = \$5236

This means a motor with 81% efficiency will cost an additional \$436 a year to run compared with a 91% efficient motor. In ten (10) years this could save \$4,360.

Controlling Motors

Wherever motors are used, they must be controlled. The motor controller will have differing features and complexity depending on the task that the motor will be performing.

The most basic type of AC motor control, for example, involves turning the motor on and off. This is often accomplished using a motor starter made up of a contactor and an overload relay. The contactor's contacts are closed to start the motor and opened to stop the motor. This is accomplished electromechanically using start and stop pushbuttons or other pilot devices wired to control the contactor. The overload relay protects the motor by disconnecting power to the motor when an overload condition exists. But an overload relay doesn't provide protection from short-circuits. For this reason, a circuit breaker or fuses are also used.

More complex motor controllers may be used to accurately control the speed and torque of the connected motor (or motors), and may be part of closed loop control systems for precise

positioning of a driven machine. For example, a numerically-controlled lathe will accurately position the cutting tool according to a preprogrammed profile, and compensate for varying load conditions and perturbing forces to maintain tool position.

Typically one motor starter controls one motor. When only a few geographically dispersed AC motors are used, the circuit protection and control components may be located in a panel near the motor.

Starting motors

A starter motor is designed to supply a motor with sufficient current to establish a starting torque to get the motor to its rated load speed. Typically one motor starter controls one motor. When only a few geographically dispersed AC motors are used, the circuit protection and control components may be located in a panel near the motor.

There are a number of starting methods that are commonly used in industry. Each method has benefits and advantages. The most energy efficient is the variable speed drive.

- **Direct-on-line starting:** stator windings directly connected to supply via contactors
- **star delta starting:** star and delta connection of stator windings are used
- **autotransformer starting:** stator windings connected to the supply through an auto transformer
- **soft starters:** variable speed drive

A quick comparison of each of the starting methods reveals that the starting current (inrush current) is considerably higher in some cases than the final current at full loaded speed:

Type	In rush current	Torque
DOL	7 x 10 amps = 70 amps	Good
Star/Delta	3x 10 amps = 30 amps	Poor
Auto/Trans	4x 10 amps = 40 amps	Good / Average
VSD	0.5-1.5 x 10 amps = 10 amps	Excellent

Motor Control Circuits

It is important for the journey exam to understand the basics of motor control symbols and ladder diagrams. A ladder diagram is a logical way to show how all of the elements of a motor control system operate. The confusing part is that the different control contacts in a device may be spread out in different places on the control diagram. They will be identified by a number or a letter. Figure below shows several common types of control devices that may be found in a ladder diagram.

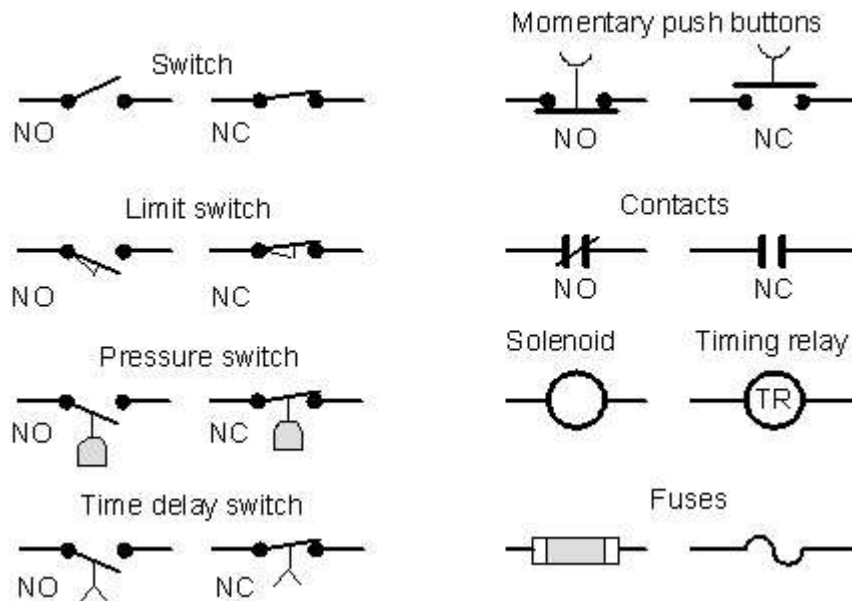

Common control devices found in a motor control ladder diagram

There are basically two types of control devices. One is normally open (NO) and requires an action to close and complete the circuit. The other is normally closed (NC) and requires an action to open the circuit.

How do you control a magnetic motor starter with a 2-wire control circuit and a 3-wire control circuit?

2-wire control circuit:

Refer figure below that shows a simple 2-wire control circuit where a pressure switch operates a magnetic motor starter. The main contacts supplying power to the motor are closed when the control system supplies power to a solenoid coil inside the motor starter. The solenoid coil is usually represented by a circle.

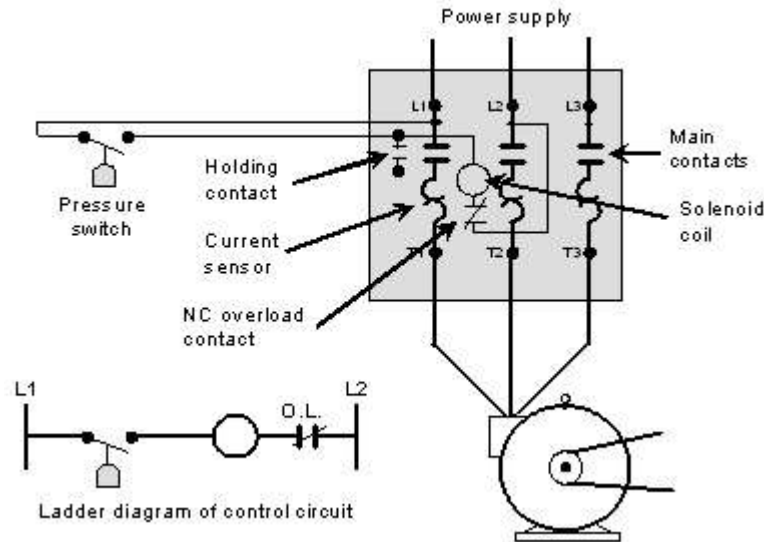

One or more normally closed contacts (NC) are installed in the control circuit to interrupt power to the solenoid in the case of a motor overload. Usually some type of device senses current to the motor and operates these overload (O.L.) contacts. In this case a 2-wire control circuit a holding contact in the motor starter is NOT needed.

3-wire control circuit:

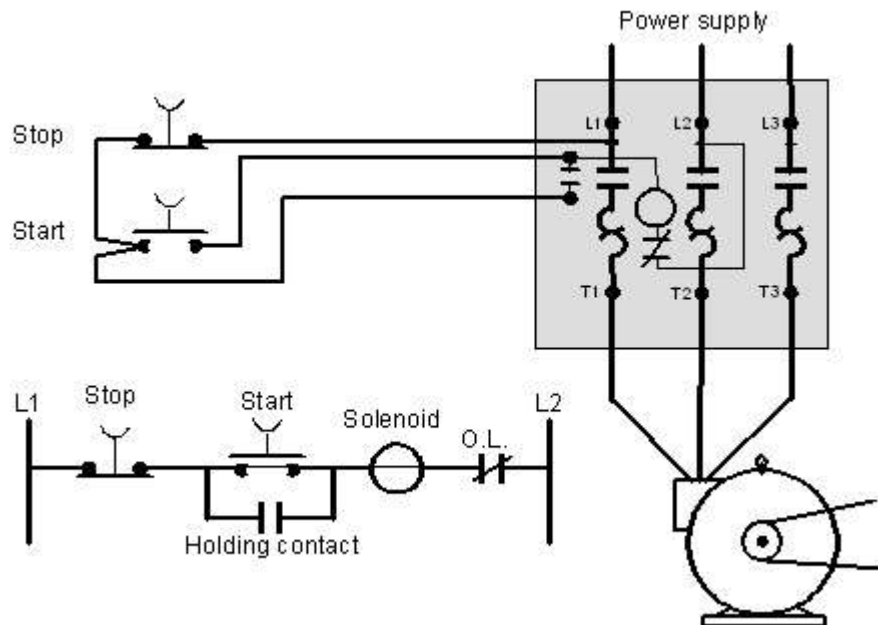

The 3-wire control circuit is used where a motor is operated using a momentary contact start-stop station. It is necessary to at least know how to control a motor with several momentary control devices. The stop push button is normally closed (NC). Pushing this button opens the control circuit and cuts power to the solenoid in the motor starter. The start push button is

normally open (NO) and must be pressed to send power to the solenoid coil. This causes the open contacts (NO) in the motor starter to close. The holding contact in the motor starter provides a path around the start push button when it is released. Any temporary interruption of power to the solenoid opens the holding contact and the motor shuts down. In the case of this 3-wire control circuit it is necessary for an operator to reactivate the circuit. For the 2-wire control circuit illustrated before, the motor will start immediately when power is restored to the control circuit.

Start Stop from 2 different locations:

Refer figure below. The stop push buttons are connected in series and the start push buttons are connected in parallel. The holding contact in the motor starter must be connected in parallel with the start push buttons.

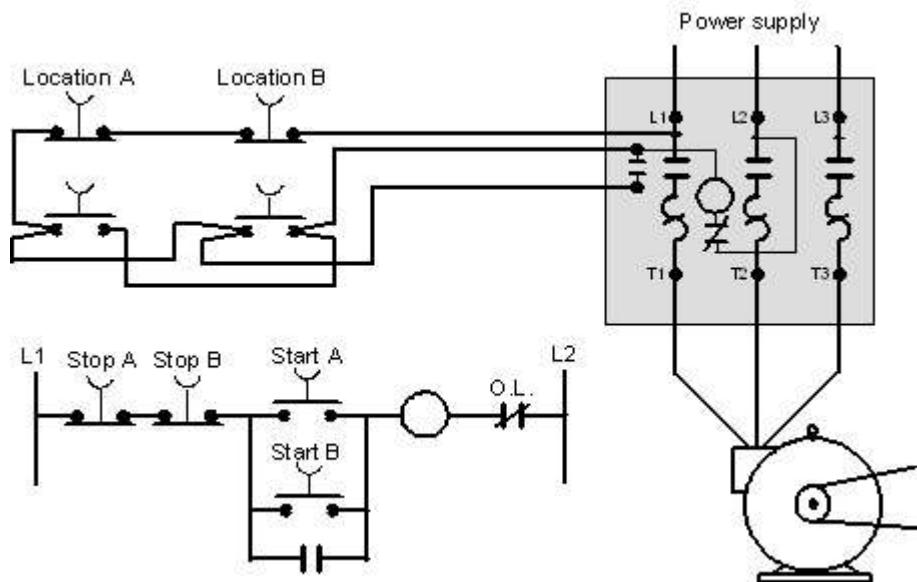

VARIABLE SPEED DRIVES

A standard motor turns at almost constant speed. But most often the loads being driven may not require the full load power that the motor can supply. This power shortfall means that energy is being wasted and so excessive greenhouse gases are being produced.

If we could control the speed of the motor so that it more closely matched the load's requirements then motor's running cost would be lower and greenhouse gases output would be decreased.

A variable speed drive (VSD) or variable frequency drive (VFD) as it is sometimes known is quite common in HVAC applications. Variable speed drives (VSDs) allow loads, such as fans and pumps, driven by AC induction motors to operate over a wide range of speeds.

Advantages of VSD

Variable speed drives:

- Improve energy efficiency e.g. savings in excess of 50% can be achieved;
- Improve power factor and process precision;
- Provide other performance benefits such as soft starting;
- Less mechanical stress on the system leading to longer life, lower maintenance overhead;
- Reduced voltage drop on startup: so other systems are less affected eg lights don't dim or other devices shut down;
- Over speed capability;
- Eliminate the need for expensive and energy wasting throttling mechanisms such as control valves and outlet dampers.

Imagine a situation in which you have 10 motors at 10 amps each starting together on small factory line. The starting currents under various starting methods would be:

- direct-on-line = 1000amps,
- soft starters = 200 amps and
- VSDs = 100 amps

What is a variable speed drive?

Recall that the speed of an induction motor is directly proportional to the frequency of the AC supply. If we can vary the frequency of the power supplied to the motor, then we can vary the motor's speed away from its rated synchronous speed. This exactly what a VSD does!

A VSD is an electronic device that converts constant frequency AC power input into a variable frequency output. This variable frequency output is used to control motor speed which, as said before, is proportional to the frequency of the VSD's output.

Principles of variable speed drives

A VSD works by converting the AC mains supply to DC using a rectifier. After smoothing by a filter, the DC supply is chopped by six transistors at a high frequency in such a way as to produce a variable frequency, variable voltage at the terminals of the motor and thus enable the induction motor to be run efficiently at different speeds.

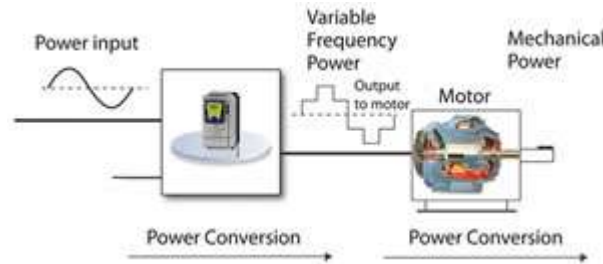

A common method used for adjusting the motor voltage is pulse width modulation (PWM).

The PWM voltage control, inverter switches are used to divide the close-to sinusoidal output waveform into a series of narrow voltage pulses, and to modulate the width of the pulses.

PWM voltage control - Three phase power is rectified, smoothed and sampled:

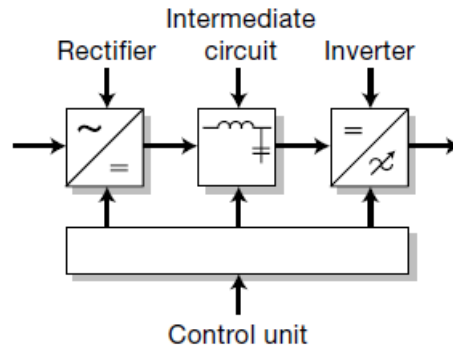
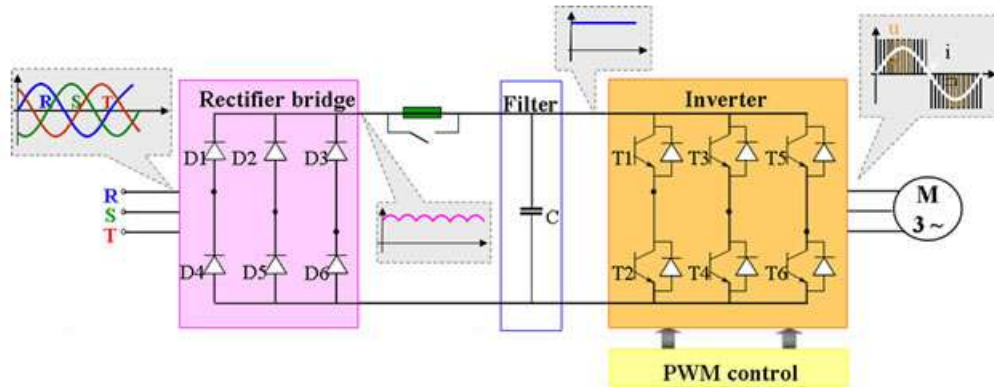

Rectifier → Rectified voltage

Filter → Smooth voltage

Inverter → Production of AC 3 phase supplied varied in frequency and voltage

The graph below shows the linear relationship between voltage, rpm, and frequency is directly related to each other.

You can see that at each frequency a new motor speed is selected.

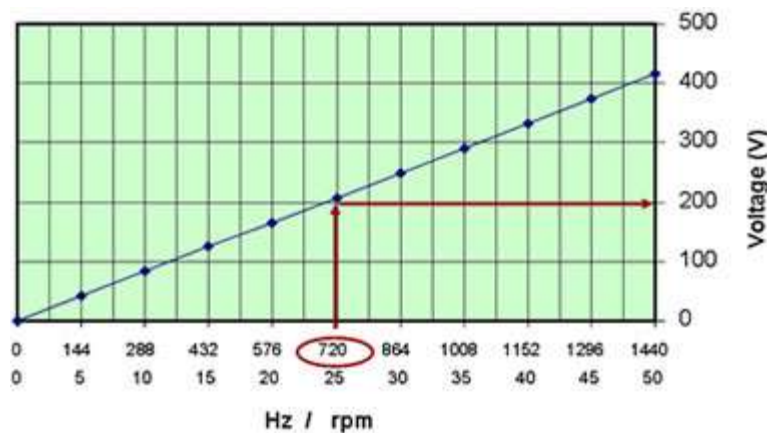

Applications:

The most obvious element in applying a VFD to a prime mover (such as fan, pumps or chiller) is to make sure the motor is rated for drive applications (inverter duty motor). Due to the abnormal stresses applied by the VFD to the motor windings and rotor laminations, any small weakness of a motor will be amplified when the motor is operated at a lower speed/frequency. The result can range from just a very noisy motor to a shorted winding or complete motor failure.

VFD produces harmonics. Make sure that the device has an integral filter and/or isolation transformers that reduces the reflected wave harmonics and prevent these harmonics from entering the distribution system.

Electromagnetic compatibility (EMC): You need to be aware that there are acceptable levels of electromagnetic radiation that can be emitted from motors, cables and control equipment. Electromagnetic compatibility (EMC) covers the unintentional generation, propagation and reception of electromagnetic energy. The goal of EMC is the correct operation, in the same electromagnetic environment, of different equipment to avoid of any interference effects.

Interference, or noise, mitigation and hence electromagnetic compatibility is achieved by addressing both emission and susceptibility issues, i.e. quieting the sources of interference

(filtering), making the coupling path between source and receiver less efficient, and making the potential receiver systems less vulnerable. Equipment and drives sold by manufacturers must comply with EMC.

Distance between the VFD and the motor is important. Winding failure can occur due to reflected wave high voltages caused by locating the motor distant from the VFD. The common-sense approach would be to keep the VFD within sight of the motor (per NEC, the distance is less than 50 ft. and within line of sight). If this is not possible, we can specify that the VFD should have an output dv/dt filter to mitigate the effects of reflections.

PART -4: ELECTRICAL ENERGY EFFICIENCY

HVAC systems are extremely large consumers of electrical energy. Over 50% of all energy used in a HVAC system is attributed to fans and pumps motors. Facilities can cut the energy costs between 10 and 25 percent through better selection and management practices. For example many buildings still use traditional mechanical devices to control system flow using inefficient throttling devices such as vanes or valves. This is tremendous waste of energy. Fan speed can be adjusted to vary the quantity of ventilation air to spaces with changing occupancies. A 20% drop in speed of centrifugal pumps and fans results in as much as 50% in energy.

This section presents some basic fundamentals of mechanical drives that will help to recognize the potentials in energy savings in HVAC systems.

PUMPS

Pumps and fans move fluids or air from one location to another. The fluid is moved using a rotating set of impellers that draw the fluid in, and then push it out.

For a fixed impeller diameter and speed, the pump has a predictable performance curve.

Where the pump operates on its performance curve will be determined by the characteristics of the system in which it is to work. The operating point is where the performance curve and the system curve cross.

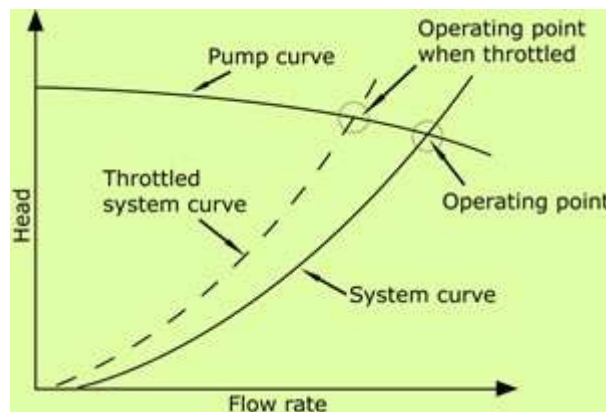

Pump and system curves cross and throttle shifts the operating points

The system curve represents all of the losses caused by friction due to the piping, elbows, valves and other physical components in the system.

The system curve is parabolic as its values are related to the square of the flow rate.

A basic pump system

A pump has two key characteristics. Fluid will be caused to flow at a particular rate, i.e. the fluid will be pushed along at a rate. Secondly, it will support a head of fluid.

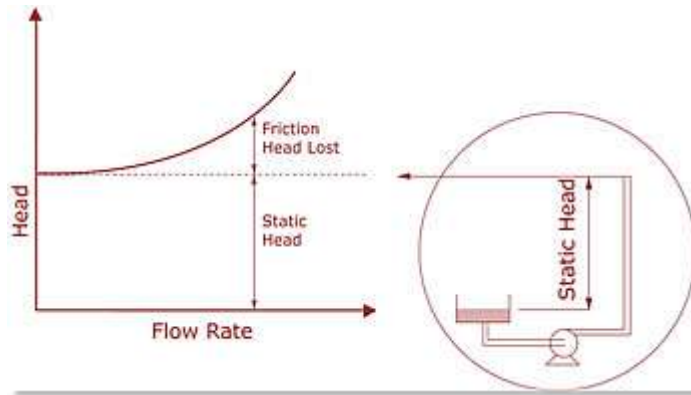

System curve showing static head and friction head lost

There are two parts as seen in the diagram:

1. Static head
2. Losses caused by friction due to the piping

A pump selected for a duty, as the pump curve is superimposed on the system characteristic curve. The curves cross over at the pump's best efficiency point (BEP) at the desired flow rate.

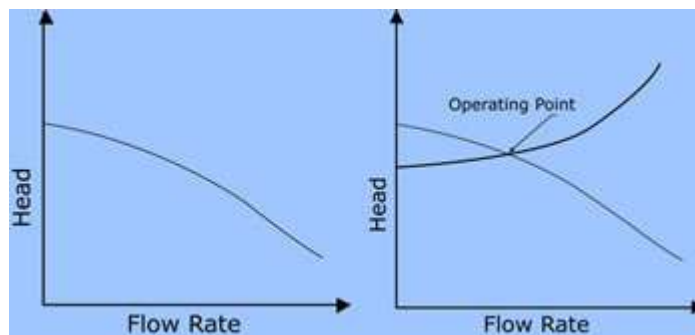

The pump curve (left) and pump curve superimposed on the system curve (right) showing the crossover point.

Obtaining a perfect match between the system curve and the best efficiency point is difficult and not practical. In fact, the pump can become unstable. In the past the following methods were employed:

1. Adjusting the pump speed
2. Adjusting the pump impeller diameter
3. Changing the impeller design
4. Adjusting the system resistance
5. Modifying static head
6. Providing a system bypass flow route.

A preferred technique is to use a variable speed drive to drive the pump as this will enable the performance of the pump to be adjusted instantaneously. The VSD motor is a very efficient, low cost method of varying the motor speed.

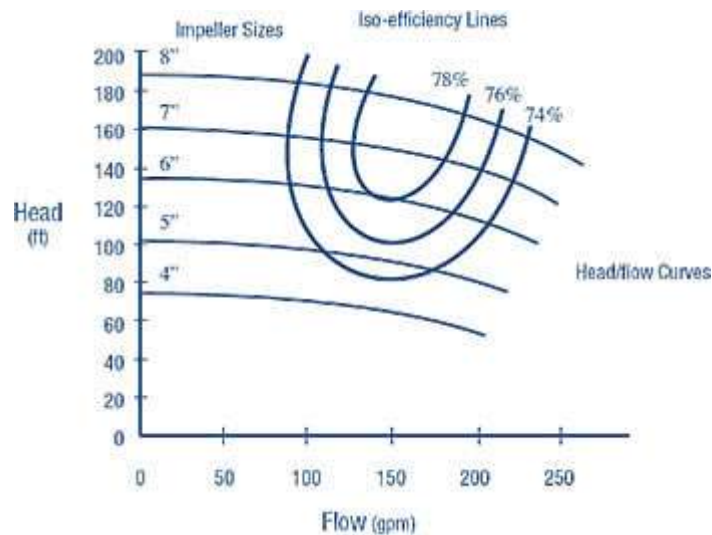

Ideal pump performance curves against impeller diameter

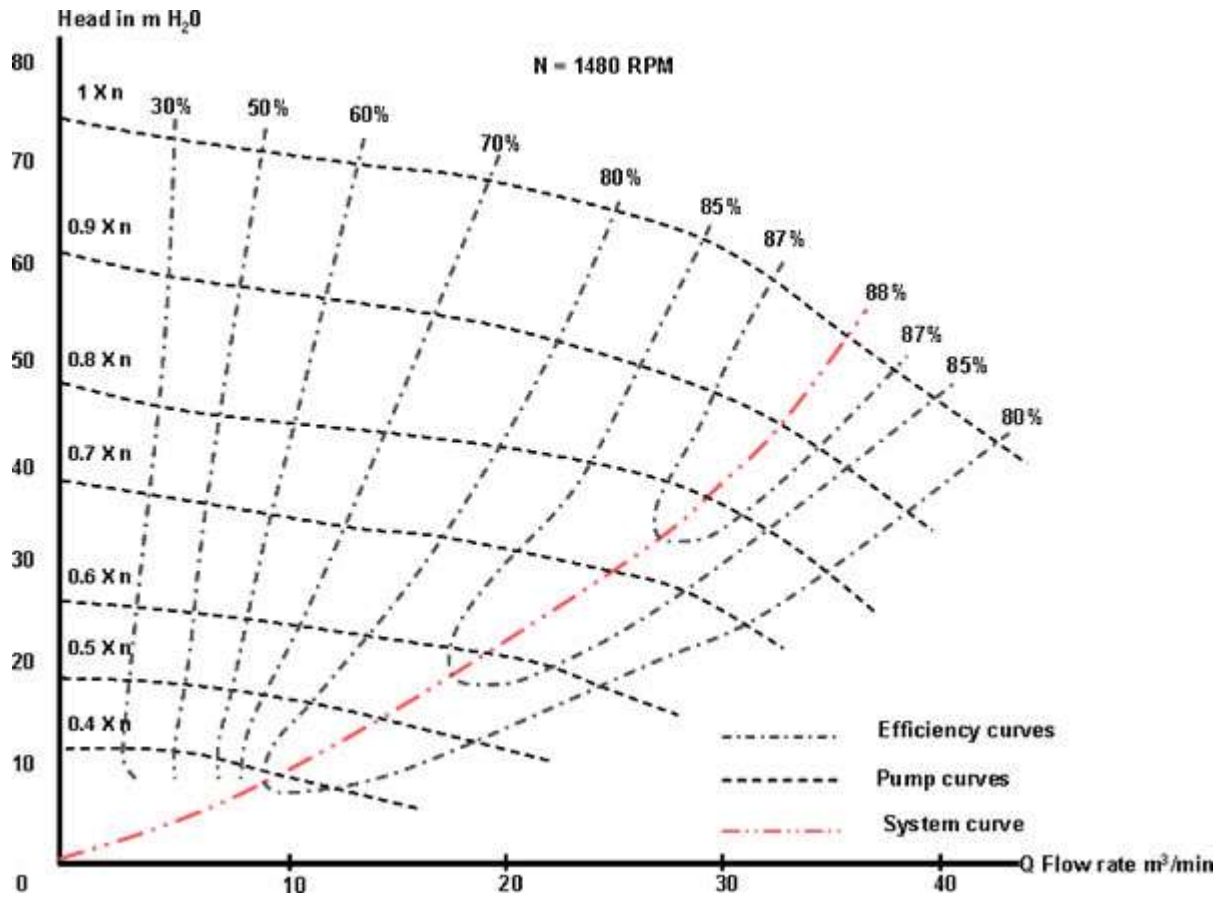

Real pump performance curves, system curves and efficiency curves

Different pumping conditions

Two main pumping conditions are often demanded:

1. Constant pressure/flow
2. Variable flow

Let's look at each of these in turn.

Constant pressure/ flow system

There are situations in which we need to maintain a constant pressure and flow. For example, a hotel's water system, a farm's irrigation system and a factory's water system. As more outlets are opened, the same flow at each outlet is still required.

Constant flow pumping:

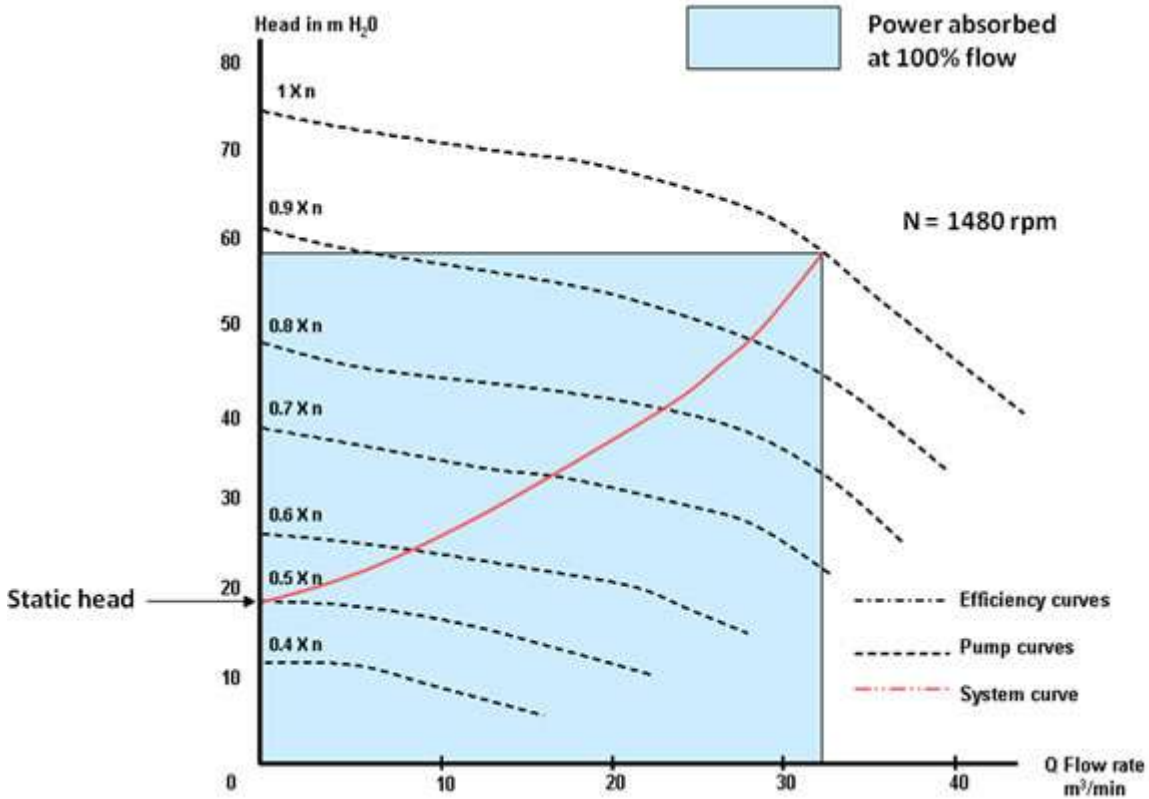

Flow control in constant pressure/flow systems

Flow can be controlled by using mechanical devices like throttle valves.

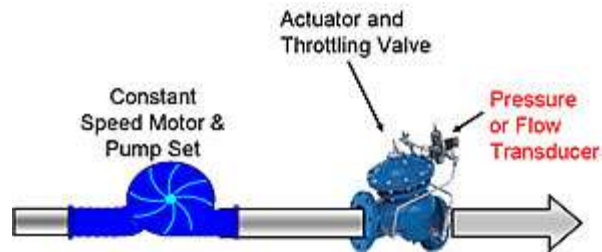

A throttle to control flow

Controlling the flow rate by throttling the pump system is wasteful of energy.

As the system is throttled the system curve will move closer to the 'head' axis.

Shown below are the 100% flow and the 50% flow.

Note that while the system is being throttled, the motor is still running at its full speed—here is our energy wastage!

As the throttle restricts flow, the operating point will move down the system curve.

As the system is throttled the system curve will move closer to the 'head' axis.

Shown below are the 100% flow and the 50% flow.

Note that while the system is being throttled, the motor is still running at its full speed— here is our energy wastage!

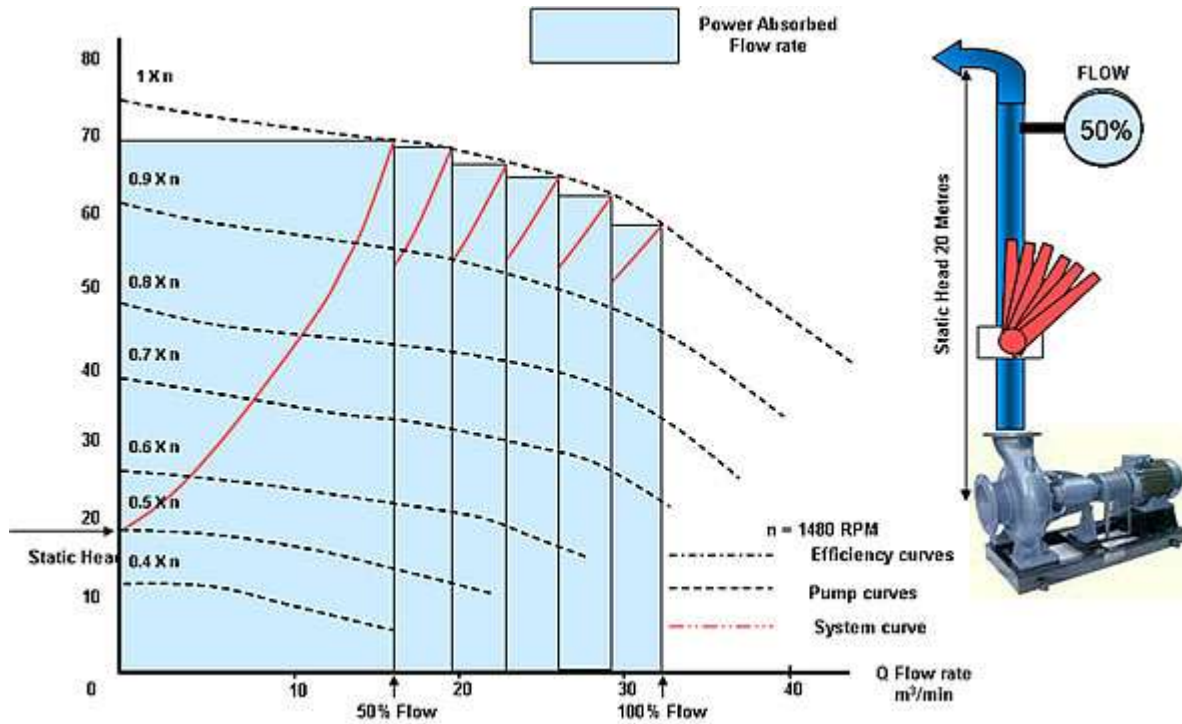

As the throttle restricts flow, the operating point will move down the system curve.

Power loss from throttling:

The following graph illustrates the extent of power loss from throttling to control flow rate.

Power loss is the upper grey area.

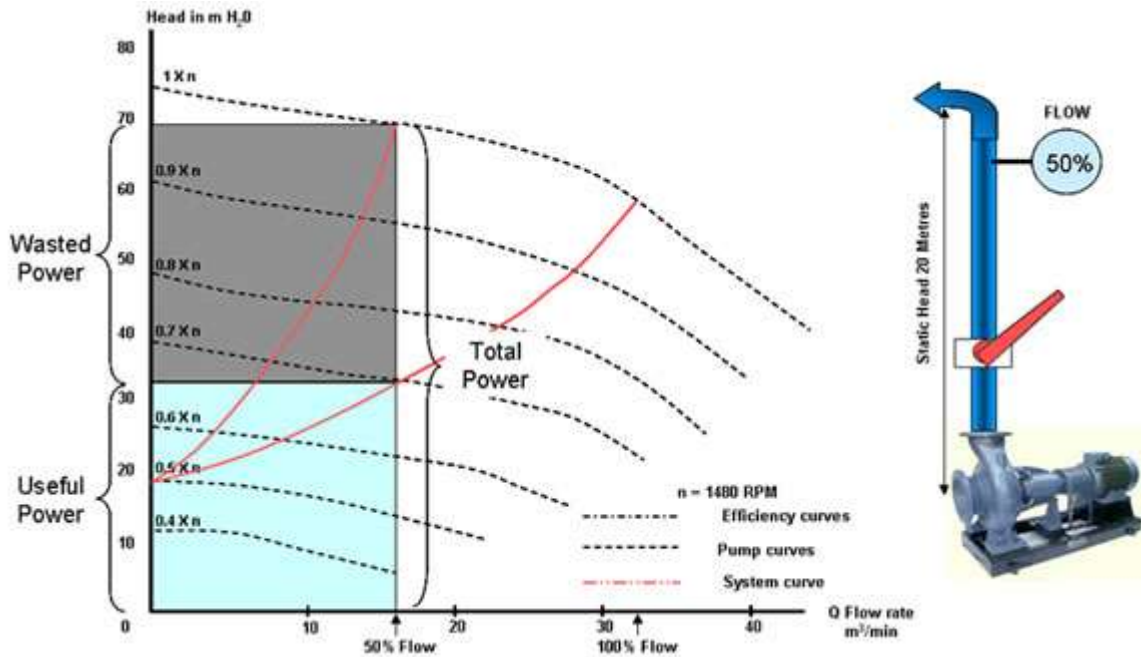

How can this energy wastage be addressed?

There are two (2) possible solutions:

1. Reduce the impeller size.
2. Install a variable flow VSD system.

Impeller trimming to reduce power loss:

If you find a system being throttled by 12% all the time, you may reduce the impeller size and reduce your energy use by 15-25%.

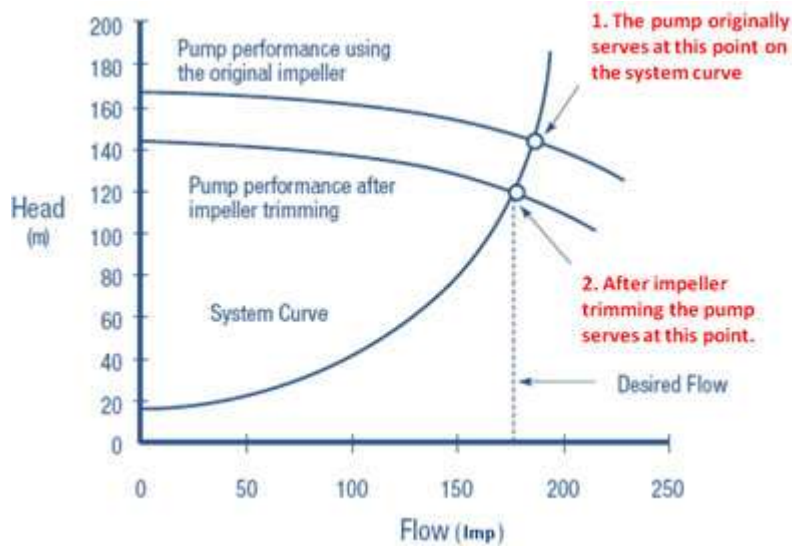

Impeller trimming resets the operating point so that flow is reduced.

Variable flow VSD systems for better efficiency:

As the VSD system responds to the changed system conditions the motor speed is reset, ie as the flow and pressure drop, so does the load (kW).

This means that the operating point of the pump follows the system curve at all times, saving enormous amounts of energy, as only the energy required is used!

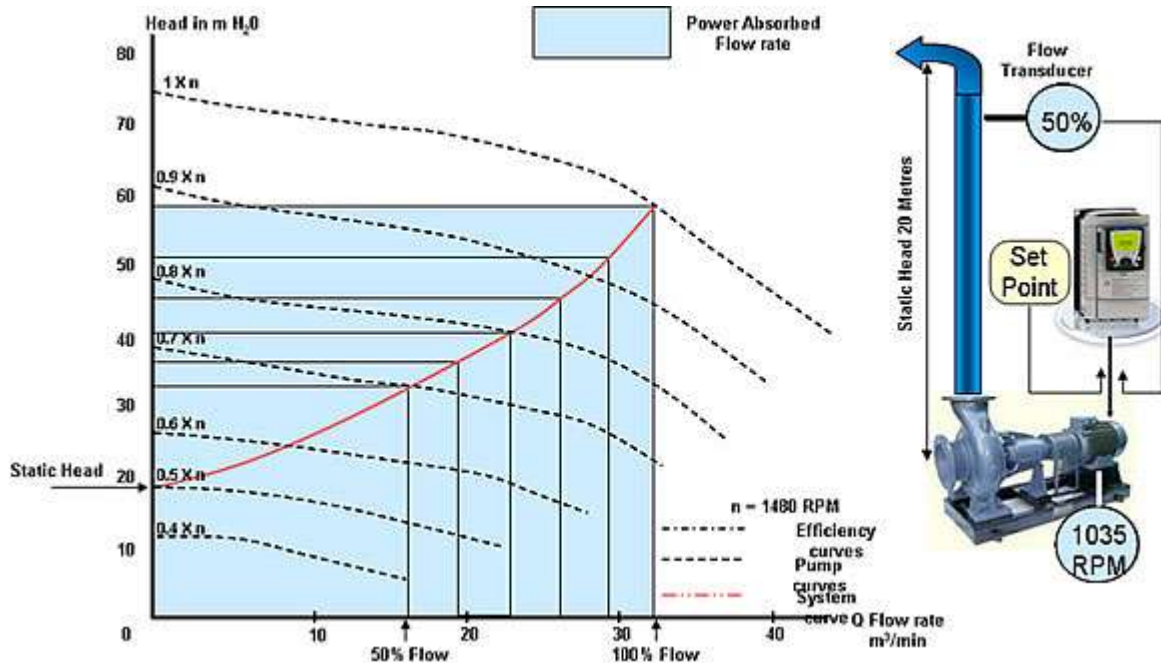

The VSD adjusts the operating point on the fly. This means there is no loss of energy.

The affinity laws

The affinity laws are used in hydraulics and HVAC (heating ventilation and air conditioning) to express the relationship between several variables involved in pump or fan performance, i.e. head, volumetric flow rate, shaft speed, and power.

1. Flow produced is proportional to the motor speed, so if we want to double the flow then we must double the motor speed
2. Pressure produced is proportional to the motor speed squared. If the motor speed is doubled then the pressure produced will be $2^2 = 4$ times greater
3. Power required is proportional to the motor speed cubed. If we want to double the speed the power required will be $2^3 = 8$ times greater.

For example:

For a 100kW pump if the flow required is only one-half (0.5) of what is rated, then the motor could be operated at:

- half speed
- the pressure would become $(0.5)^2 = 25\%$ of rated.

The power required to operate the pump would be $100\text{kW} \times (0.5)^3 = 12.5 \text{ kW}$.

There are a number of alternative pump control solutions.

The graph compares the energy usage of each control solution.

From the three (3) curves you can see that VSD out performs the use of throttles and bypass valves, except at close to 100% load.

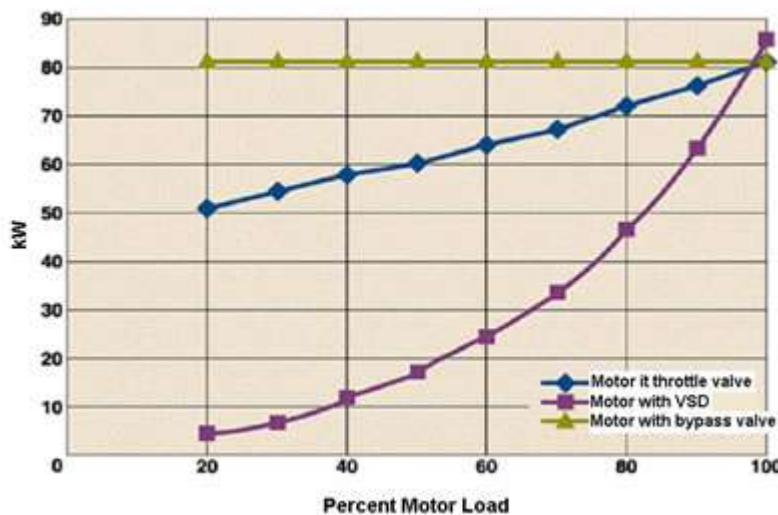

VSD power usage is lower than the mechanical flow controls

FANS

Fans control the flow of air. There are a number of ways of controlling airflow. The diagram illustrates all three methods.

1. Guide vanes
2. Adjustable pitch blades
3. Throttling valve

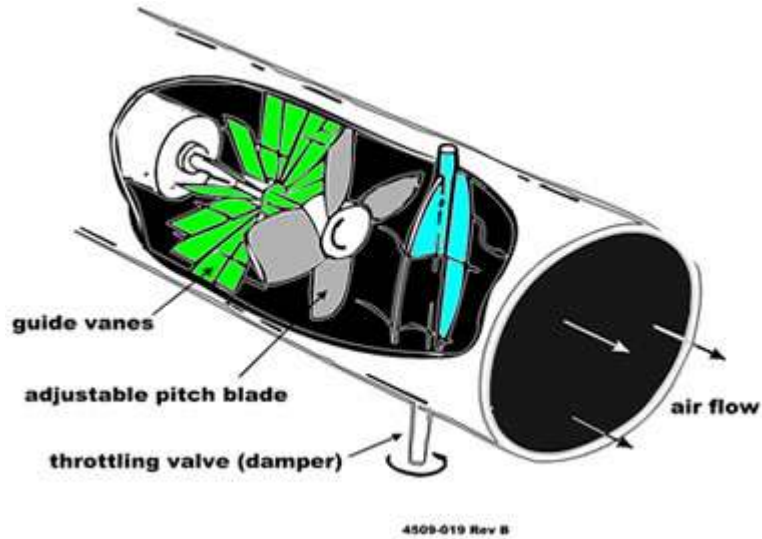

Vanes, pitch blade and throttle valve methods of air flow control in fans

Fan performance:

The performance of a fan can be graphed as seen in the fan curve and system curve below.

The performance, not surprisingly, has similarities to that of pump performance.

As the airflow increases, the pressure dips, this is seen in the fan curve.

The air is fed into an arrangement of pipes and other devices that form a system.

The operating point for the fan is at the intersection of the two curves.

You should note that the frictional effect of the system soaks up some power.

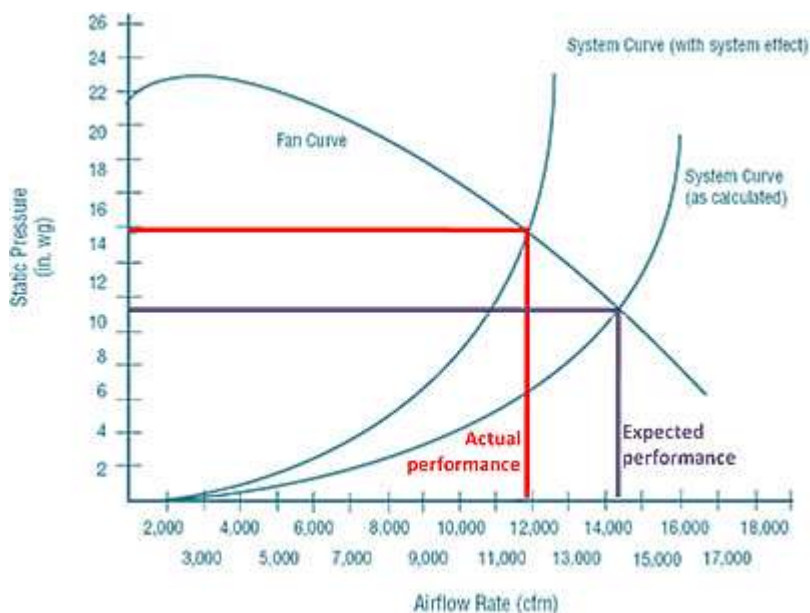

Fan curve and system curves

Power requirements for airflow control:

Each method of airflow control imposes an energy loss burden or energy losses. You can manage the energy wastage by the proper choice of airflow control.

The effects are different for each airflow control as seen in the figure.

1. VSDs
2. Controllable pitch
3. Inlet vanes
4. Outlet vanes

Example calculation:

Compare the power savings of using VSD to drive six (6) 1kW fans. The fans feed into identical systems of duct work and fixtures.

Calculate the power requirement if the airflow is halved (1/2) using either system.

Solution:

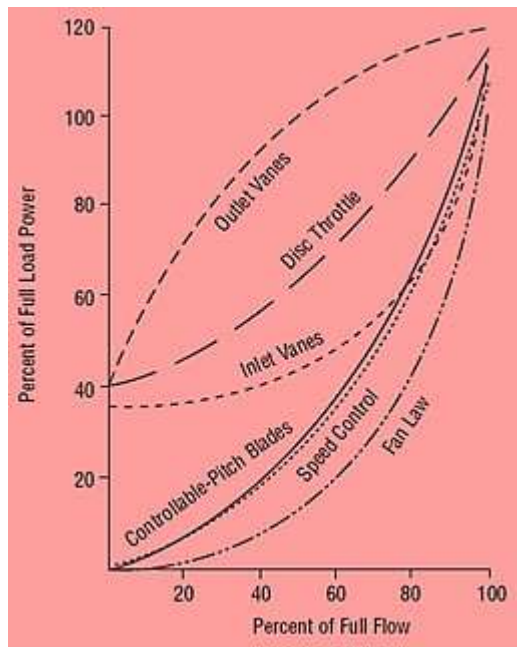

Fan and system curves to show the effects of different flow controls

To achieve half the air flow in the non VSD system simply requires the plant to switch off half of the fans, therefore power consumption is $3 \times 1\text{kW} = 3\text{kW}$.

Using the affinity law or fan law the VSD solution can be seen to consume 0.75kW compared to the non VSD system that consumes 3kW .

See the diagram below:

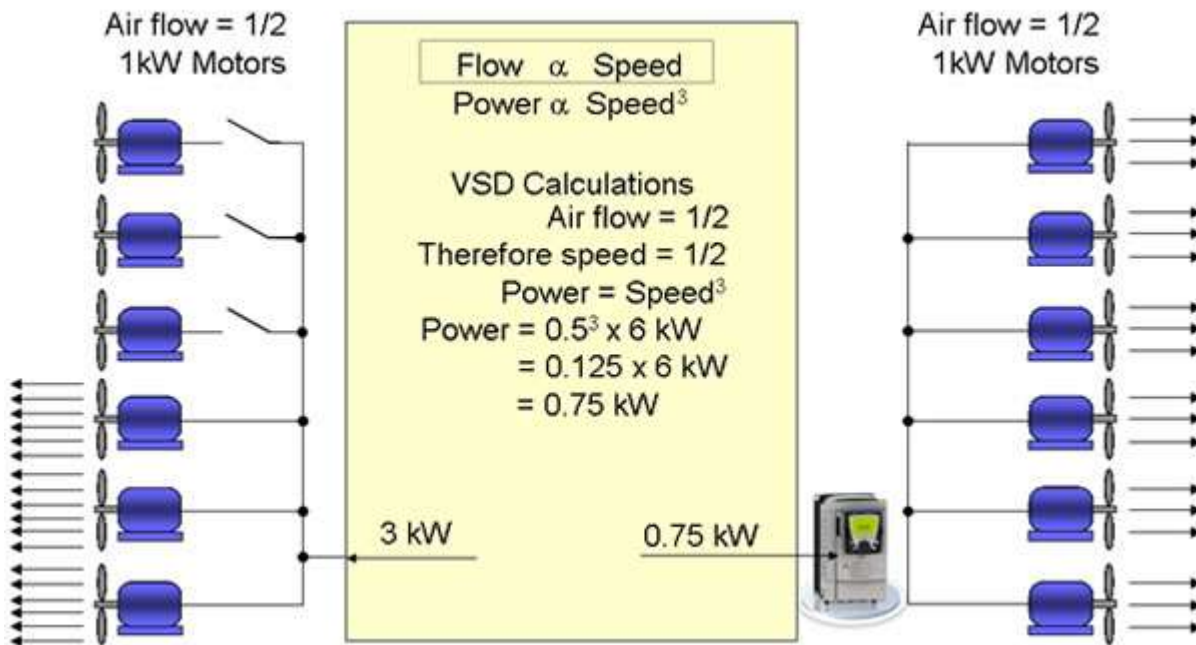

Comparison of VSD and non-VSD control for multiple fans

CHILLERS

Chillers typically consume more electricity than any other single energy-consuming device in a large commercial building. A packaged water-cooled chiller produces chilled water for use in your building's air conditioning system and is typically 40 per cent more efficient than air-cooled chillers due to lower condensing temperatures. Upgrading existing equipment with a variable speed drive can also reduce energy consumption in your building significantly.

Chillers are usually selected based on their efficiency when providing 100 percent of their cooling capability, but most rarely operate at this condition. There are a number of ways to express the efficiency of a chiller, but probably the most common metric is kW of electrical input per ton (12,000 Btu/hr.) of cooling produced, abbreviated as "kW/ton".

The manufacturers often tout “0.55 kW/ton” chiller efficiency (or better) at full load, hoping that this implies efficiency under all conditions; it is more significant in most cases to know the efficiency across the spectrum of loads from 10 to 100 percent.

Three methods for improving chiller plant load efficiency are:

1. Specify a chiller that can operate with reduced condenser water temperatures;
2. Specify a variable speed drive (VSD) for the compressor motor. From a practical standpoint, centrifugal chillers only are available with VSD and VSDs are not often used with other compressor types (reciprocating, scroll, or screw compressors);
3. Select the number and size of chillers based on anticipated operating conditions.

How Chiller Efficiency is measured?

- Coefficient of Performance (COP) [$W_{\text{cooling output}}/W_{\text{power input}}$] - the ratio of the rate of heat removal to the rate of energy input to the compressor. Higher values correspond to improved efficiency.
- Full Load Efficiency [kW/ton] - the ratio of the rate of power input (kW) to the rate of heat removal, in tons (1 ton = 12,000 Btu/hr). Lower values correspond to improved efficiency.
- Integrated Part Load Value (IPLV) [kW/ton] - the weighted average cooling efficiency at part load capacities related to a typical season rather than a single rated condition at rating conditions specified by ARI Standard 550 or 590, depending on chiller type.
- Applied Part Load Value (APLV) [kW/ton] - calculated the same way as IPLV, but using actual chilled and condenser water temperatures rather than those specified by ARI standard rating conditions.
- Non-Standard Part Load Value (NPLV) [kW/ton] - a revision of APLV that provides a more realistic model of off-design performance.

Selecting a chiller

When selecting a chiller for your business, you should:

- Review your air conditioning needs: buying more capacity than you need increases your initial costs and could increase your monthly bills for the life of the equipment, which can be up to 30 years.

- Obtain competitive bids: different equipment manufacturers will offer various performances and efficiency options, many of which provide different benefits and system interactions. A consulting engineer can be employed to conduct an independent review of all selections.
- Select a chiller that operates at a lower kW//ton at part load: a chiller that is most efficient at peak load may not result in the most efficient operation over the entire cooling season. Selecting chillers that operate at a lower kW/ton at part load may be the better option.
- Expect to pay more up front: realize that this is often money well spent. Even modest improvements in chiller efficiency can yield energy savings and attractive incentives and paybacks.
- Consider selecting machines of different sizes for multiple chiller installations: select one machine small enough to meet light loads efficiently and the other(s) to meet larger loads efficiently.

COOLING TOWERS

Cooling towers are an important part of many HVAC systems. The cooling tower fans remove heat from the water.

The fan speed is controlled to maintain the optimal condenser water temperature.

The fans are the number one user of power in a cooling tower, and that's the first place to look for energy savings.

The advantage of using variable speed drives is due to a fan's power variation as the cube of the airflow rate and thermal performance varies directly.



Examples of cooling towers

AIR HANDLERS

The central air-conditioning system consists of two main parts: an outdoor unit and an indoor unit.



The air handler is the indoor unit, which includes a coil and an air blower.

Its job is to circulate the conditioned air throughout the building.

In an 'Air handling unit' (AHU) the fan is the largest energy consumer.

Energy savings from mechanical components

Mechanical belts

Flat drive belts and V-belts are less efficient as they have greater slip over a pulley. In addition, V belts deteriorate with age by about 4% of efficiency – plus a further 5-10% if the belts are poorly maintained. Oversizing and undersizing V belts can produce additional losses.

Cogged systems have less slip and so less energy is wasted in slippage. In addition cogged system needs less maintenance.

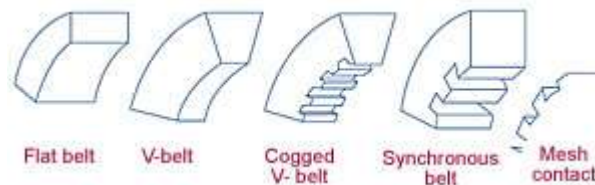

Drive and linkage belts

Belt alignment

Correcting any misalignment of belts will save substantially on the wear and tear on both the motor and the motor shaft. Ensure belts are properly tensioned. For belt drives, mounting the motor on slide rails allows both alignment and belt tension to be easily adjusted.

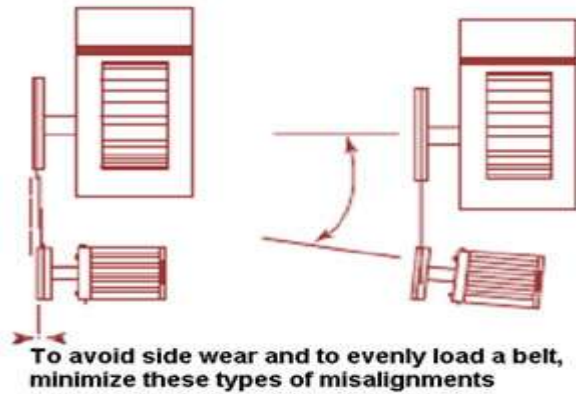

Overall system efficiency

The HVAC system diagram below identifies the losses in a typical system:

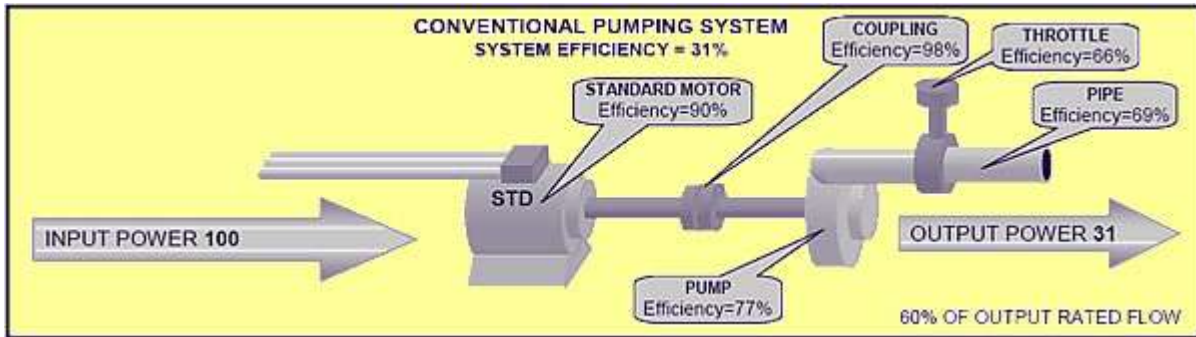

Calculation:

Referring to the figure above, calculate the power losses:

1. Motor output power = 90% of 100 = 90
2. Coupling output = 98% of 90 = 88.2
3. Pump output = 77% of 88.2 = 67.9
4. Throttle output = 66% of 67.9 = 44.82
5. Pipe output = 69% of 44.82 = 30.93

The system loses a great deal of power. 100 units of power are input, but the system delivers only 31 units of power out. This represents a 31% efficient system. There is a lot of room for improvement.

ELECTRICAL STANDARDS

In US there are three major organizations that help to standardize equipment specifications and safety regulations within the electrical industry.

1. NEMA or the National Electric Manufacturers' Association is the major one that issues technical standards and specifications, which are often cited in the manufacturers' descriptive data about its products.
2. ANSI, the American National Standards Institute provides operating standards for utilities.
3. NEC or National Electrical Code is a comprehensive building code standards book sponsored by the National Fire Protection Association. It's revised every three years and its primary purpose is the protection of life and property.

In addition to NEC, the National Fire Protection association issues other standards related to the electrical field, which you'll also want to consult if your region has adopted them as law.
