



**PDHonline Course E230 (3 PDH)**

---

**Design to the Fire Alarm Code, NFPA  
72-2007**

*Instructor: Thomas Mason, P.E.*

**2020**

**PDH Online | PDH Center**

5272 Meadow Estates Drive  
Fairfax, VA 22030-6658  
Phone: 703-988-0088  
[www.PDHonline.com](http://www.PDHonline.com)

An Approved Continuing Education Provider

## Design to the Fire Alarm Code, NFPA 72-2007

Thomas Mason, P.E.

### Course Content

A fire alarm system has a number of essential components, whether protecting a historic jail in a park, a high-rise apartment, a school, a retail business or a factory. Some essential components and fire alarm nomenclature are illustrated below:

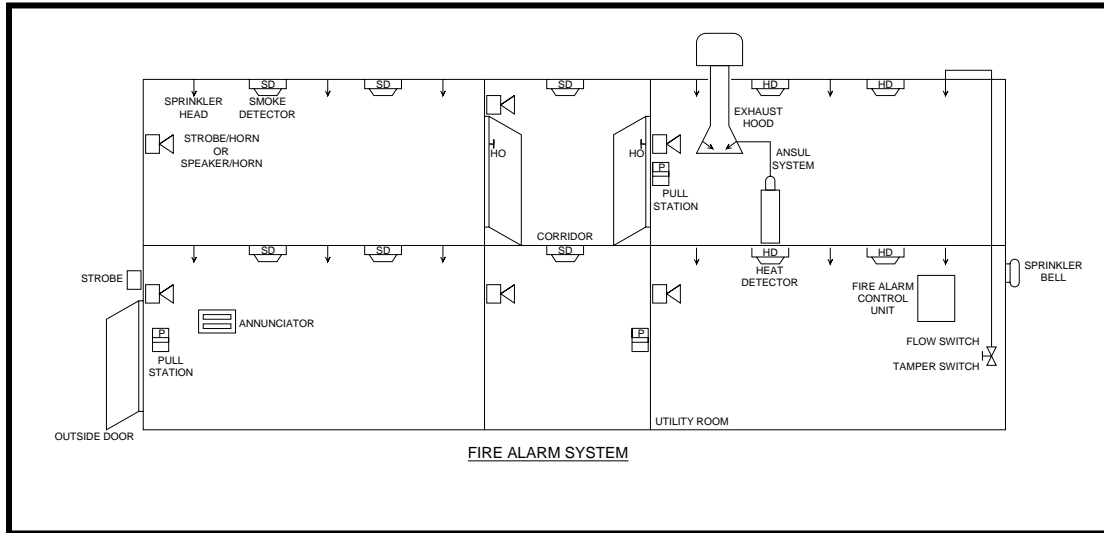

where,

- sprinkler head = mechanical device to release a spray of water into the space
- smoke detector = electrical device to signal the presence of smoke, part of the general group, “initiation devices”
- ho = magnetic door hold = electrical device to hold door open until alarm, usually connected to the group, “notification devices”
- heat detector = electrical device to signal a high temperature or a rapid rise in temperature, part of the general group, “initiation devices”
- pull station = electrical device to permit manual initiation of alarm
- flow switch = electrical device to signal operation of the sprinkler system, part of the general group, “initiation devices”
- tamper switch = electrical device to signal that the valve is not “full open”, part of the group, “supervisory devices”
- strobe/horn = electrical device providing visual and audible indication of alarm, part of the group, “notification devices”
- strobe/speaker = electrical device providing visual and audible indication of alarm, part of the group, “notification devices”
- fire alarm control unit = (formerly fire alarm control panel), central device and logic for the fire alarm, usually contains 24-hr batteries
- annunciator = electrical device for visual report of location of alarm initiation

sprinkler bell = electrical device for audible report of sprinkler operation  
outdoor strobe = electrical device for visual report of building with alarm  
Ansul = brand name (Tyco) of a local fire suppression system, usually connected to the group “initiation devices”  
mag lock = electric device in the security system, connected to the group “notification devices”, may be fail-safe or fail-secure  
Elevator = normal path or egress, usually safely shutdown during alarm by auxiliary relay in group, “notification devices”

**Building classification and Architect design responsibilities:** The illustration above introduces the first consideration in fire alarm design - “Is a fire alarm required?” and “What type of fire alarm is required?”

















The answers come from interpretation of the Building Code against the present facility. An architect is specially trained to make this interpretation. The underlying questions are building construction type and building usage type. The designer must understand enough to ask the right questions, but the Architect should provide the answers and sign and date the document. In construction projects, there is a lead sheet which summarizes the construction type and use group, but it is often not in the set provided to the electrical designer. A new PDHonline course G10, entitled, “National CAD Standard 3.1-07” presents Architect responsibilities in the construction drawing package.

Another key question is occupancy. That is, “How many persons are expected to be in a room?” If the answer is 50 or more, it is a place of assembly and normally requires more devices than an office or work room. The Architect decides.

**CAUTION:** If a fire alarm is not required by the Building Code, but the Owner chooses to install one anyway, it **MUST COMPLY** with the Fire Alarm Code.

**Standard terms, abbreviations and symbols:** Terms, abbreviations and symbols are not rigidly defined by NFPA 72, but there are a number which are commonly used and it is essential to include a legend of the abbreviations and symbols used in a design.

The following is a legend sheet from a recent fire alarm project:

SYMBOL	DESCRIPTION
	DISCONNECT SWITCH - HEAVY DUTY - SIZE AND TYPE AS INDICATED ON DRAWINGS. NEMA 3R ENCLOSURE.
	INCANDESCENT WEATHER-PROOF LIGHT FIXTURE DAY BRITE VIS 150-1-12WG
 GFI	DUPLEX RECEPTACLE - GROUND FAULT CIRCUIT INTERRUPTER HUBBELL GF5262I IN WEATHER-PROOF ENCLOSURE
	SINGLE POLE TOGGLE SWITCH HUBBELL #12211 - 20A. 120-277V. -IN WEATHER-PROOF ENCLOSURE
 M	FRACTIONAL HORSEPOWER MANUAL STARTER - NEMA TYPE 1 SQUARE D CAT. NO. FG1
 3	THREE-WAY TOGGLE SWITCH HUBBELL #9643-1 20A. 120V -WITH IVORY COVER PLATE
	PANELBOARD - 225A 240/120V 1Ø, 3W, WITH 225A. MAIN CIRCUIT BREAKER SQUARE D NQ0D442L225CU, 22,000 AIC MAIN AND BRANCH CIRCUIT BREAKERS
	FIRE ALARM PANEL SIMPLEX 4010 OR APPROVED EQUAL
	IONIZATION SMOKE DETECTOR SIMPLEX 4098-9717 IN 4098-9789 BASE OR APPROVED EQUAL
	PHOTOELECTRIC DETECTOR SIMPLEX 4098-9714 IN 4098-9789 BASE WITH OR APPROVED EQUAL
	HEAT DETECTOR SIMPLEX 4098-9733 IN 4098-9789 BASE OR APPROVED EQUAL
	MANUAL PULL STATION - ADDRESSABLE TYPE MOUNTED 45" A.F.F. SIMPLEX 4099-9003 IN 2975-9178 SURFACE BOX OR APPROVED EQUAL
	SIMPLEX 4098-9756, 2098-9806 REMOTE LED AND TEST 2098-9806, PAM-SD REMOTE RELAY OR APP. EQUAL DUCT SMOKE DETECTOR - FURNISHED AND INSTALLED BY ELECTRICAL CONTRACTOR
	AUDIBLE VISUAL APPLIANCE MOUNTED 78" A.F.F. SIMPLEX 4903-9424 HORN/STROBE, SYNCHRONIZED, 110 CANDELA, OR APPROVED EQUAL
	VISUAL APPLIANCE MOUNTED 78" A.F.F. SIMPLEX 4904-9310, SYNCHRONIZED, 110 CANDELA, OR APPROVED EQUAL
	#12 CONDUCTORS IN 1/2" CONDUIT WITH GREEN WIRE GROUND. CONCEALED IN WALL OR CEILING
NP-X	NAMEPLATE DESIGNATION SEE DRAWING E-7.
	TELEPHONE OUTLET FLUSH IN WALL WITH IVORY COVER PLATE - 18" A.F.F. 3/4" CONDUIT STUBBED INTO CEILING WITH INSULATED BUSHING

The key concepts in choice of fire alarm symbols are uniqueness and recognition. If “V” in a box means fire alarm visual notification device, it must not be used for ceiling speaker volume control. “S” in a box usually means ceiling speaker, so this designer chose a hex box for ionization smoke detector.

There is a controversy over putting manufacturer and part number on the drawings, as opposed to including them in the specification. The example symbol legend shows Simplex part numbers, “or equal”. This actually constitutes a specification, since Simplex documentation is widely available and readily comparable to third-party suppliers.

For the example symbols above, the horn symbol for an audible/visual notification device is very recognizable (even though they don’t look like that any more).

This example is immediately usable, except for the lack of a remote annunciator. The most common reason for rejected fire alarm designs is lack of an annunciator panel at the firefighters’ entrance. A box with the text “ANNC” is sufficient for the plan. Some description (and a Simplex part number for this example) are required for the legend.

This might be a good point to discuss the break in responsibility between the electrical designer and the fire alarm contractor. In almost all cases, the designer is preparing a package to be bid. He probably should not be brand-specific. Also, different manufacturers and different models from the line of a single manufacturer use different devices to connect to remote devices. An addressable system will require an interfacing relay with a multiplexer to connect to an Ansul system. A hardwired system can connect directly to terminals on the local panel. Your instructor recommends AGAINST providing detail to the level of wiring, interfacing relays and multiplexers. A general note on the drawing and in the specification should indicate that the provider is responsible for a “complete, operating system, satisfactory to the Authority Having Jurisdiction.”

**Riser diagrams:** Riser diagrams are a schematic representation of the fire alarm system, identifying the central panel and remote devices. Thirty years ago, each room of the facility was identified and the devices in that room. Today, the riser is much less detailed, as the example below, used on over 50 schools in different districts:

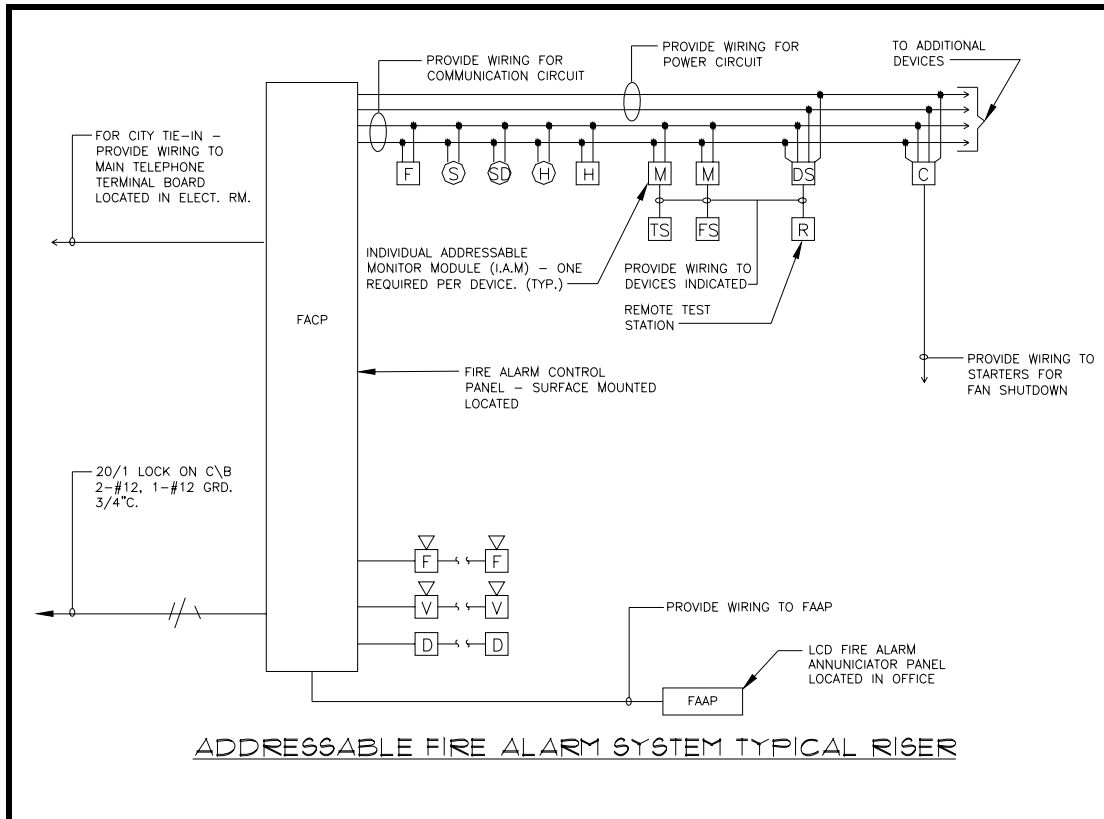

Note that this designer used different, though recognizable, symbols for the fire alarm devices. A characteristic of this example is the explicit indication of power wiring for the sensing devices. Wiring of the notification devices and interface is not similarly detailed. There have been no requests for information from confusion arising from this riser diagram.

A fire alarm system for a large facility will usually have remote power supplies to permit extending sensors and notification devices without grossly oversized power conductors. This is a detail design addition, after the voltage drops have been calculated and a responsibility of the installing supplier and contractor.

The actual wiring of the remote devices is here shown schematically, rather than pictorially. Tee-taps, as shown, are forbidden. The devices must have two incoming terminals and two outgoing terminals, even on a two-wire circuit.

The riser diagram answers many field questions if done carefully. Show duct detectors if there are duct detectors. Show specialized sensors if they exist. Definitely show connection to independent suppression systems, as kitchen hoods. This avoids claims for a Change Order if the Contractor overlooks the device in his bid calculations.

The following is a much more sophisticated fire alarm riser diagram and the corresponding notes:

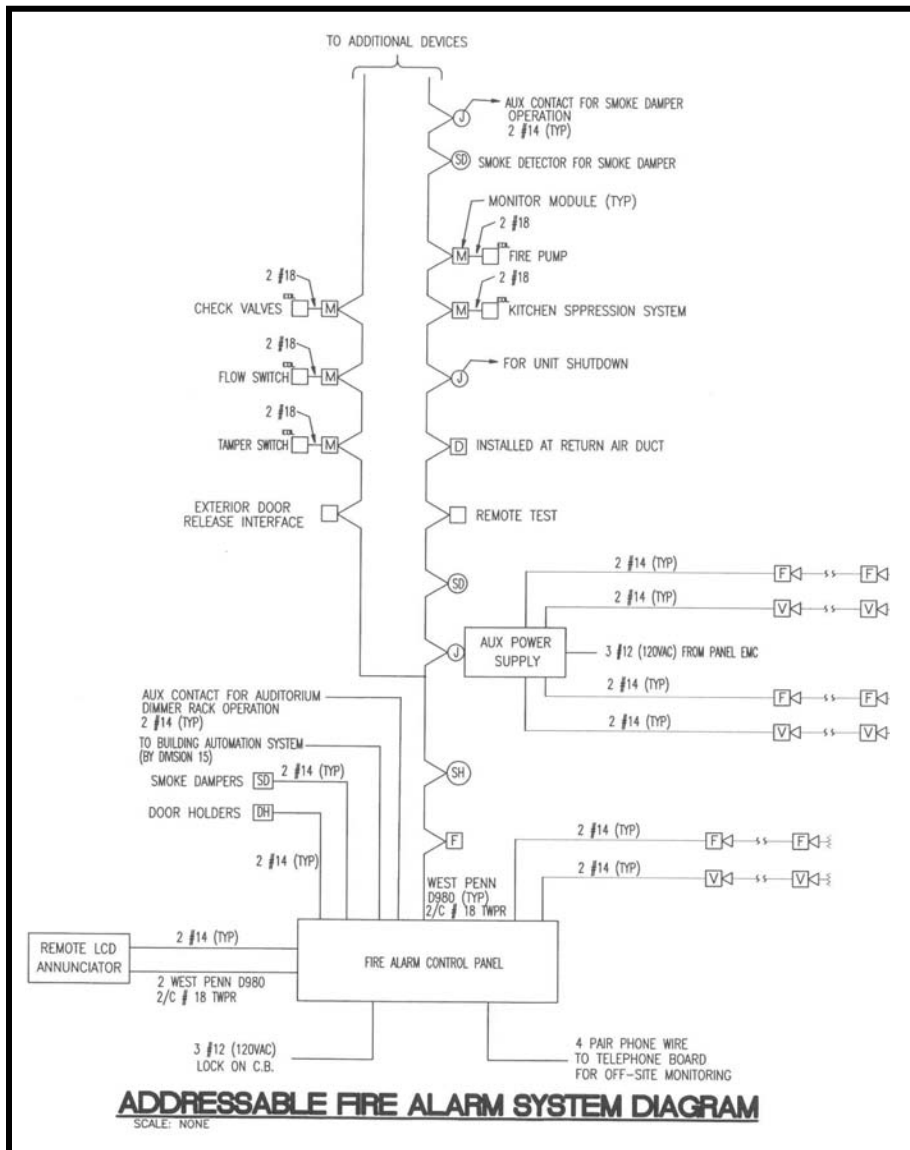

Your instructor advises AGAINST this level of detail. Unless the designer is very sophisticated and exactly the system envisioned is installed, there will be discrepancies - which result in field change orders, paperwork, costs and bad feelings.

For example, 2#14 conductors are specified to the smoke dampers (square SD). It is totally acceptable to provide a supervised relay from the digital loop and pick up power from the air handling unit. By specifying power from the fire alarm panel, the dampers will not close when the air handler shuts down. This is usually NOT the desired sequence of operation. In order to close the damper on unit shutdown, a signal will have to be picked up from the air handler and the control sequence programmed in the fire alarm panel.

A better design would be to vaguely indicate the connection between the fire alarm and the smoke damper and task the fire alarm installer with coordination with the HVAC installer.

Such coordination is essential to accommodate late design changes and discovered field conditions.

The LCD annunciator is another problem. This was a State funded school job. The State funding agency forbids LCD annunciators (see the discussion on specifications). If the riser just said "remote annunciator" the problem would go away.

## **ADDRESSABLE FIRE ALARM SYSTEM DIAGRAM**

SCALE: NONE

- 1.) THE RISER REPRESENTS A TYPICAL SYSTEM AND IS NOT INTENDED FOR INSTALLATION, SYSTEM SUPPLIER SHALL PROVIDE INSTALLATION DRAWINGS AND WIRING DIAGRAMS. EXACT SYSTEM REQUIREMENTS SHALL BE COORDINATED WITH THE SYSTEM SUPPLIER.
- 2.) EACH DUCT TYPE SMOKE DETECTOR REQUIRES A REMOTE TEST STATION, CLEARLY MARKED AND CONVENIENTLY LOCATED WITHIN REACH ABOVE FLOOR. SEE MECHANICAL DRAWINGS FOR LOCATIONS OF DUCT SMOKE DETECTORS PRIOR TO INSTALLATION.
- 3.) THIS DIAGRAM IS NOT INTENDED TO SHOW EXACT QUANTITIES OF DEVICES. REFER TO DRAWINGS FOR DEVICES QUANTITIES AND LOCATIONS.
- 4.) PROVIDE ADDITIONAL ADDRESSABLE MONITOR AND CONTROL MODULES AS RECOMMENDED BY THE SYSTEM SUPPLIER.
- 5.) SEE FIRE PROTECTION SHEETS FOR LOCATIONS OF FLOW SWITCHES AND TAMPER SWITCHES.
- 6.) CONTRACTOR SHALL GET APPROVAL FROM LOCAL AUTHORITY HAVING JURISDICTION AND INCORPORATE ALL REQUIREMENTS OF AUTHORITY HAVING JURISDICTION. ANY REVISIONS REQUIRED SHALL BE DONE BY THE CONTRACTOR WITHOUT ADDITIONAL COST TO OWNER.
- 7.) THE CONTRACTOR SHALL TEMPORARILY KEEP EXISTING HIGH SCHOOL FIRE ALARM SYSTEM RUNNING UNTIL NEW FIRE ALARM IS INSTALLED.
- 8.) THE FIRE ALARM SHALL AUTOMATICALLY BRING THE AUDITORIUM HOUSE LIGHTS TO FULL-ON

The notes for this project are not identified as notes, however, they introduce three important details not found in the later notes examples - duct detector test station, continued operation of the existing fire alarm system and auditorium egress lighting. A change in the Fire Alarm Code requires remote test stations for duct smoke detectors that are not readily accessible. They are available in many forms, but most contain a test switch and a reset switch. They are part of the duct detector, not part of the fire alarm system. The note calls them out correctly, but the riser shows them incorrectly.

Continued operation of the existing fire alarm system is required for occupied spaces and construction spaces. The requirement is usually ignored because wiring is ripped out during demolition and new temporary wiring must be run to provide detectors and pull stations. The temporary wiring must be ripped out when the building is turned over to the owner. Expensive and expensive again.

The second reason for ignoring the requirement for an operable fire alarm during construction is construction dust. It trips smoke detectors. For small construction jobs, the smoke detectors are "bagged" and taken out of service, though still connected. They are supposed to be replaced by heat detectors.

Auditorium egress lighting triggered by the fire alarm is relatively new requirement. Inspectors are beginning to require it and verify that it is installed. Unfortunately, there are complications which cause it to be disabled shortly after the test.

The concept behind the requirement is that the audience should be able to exit the auditorium when the fire alarm sounds. During a performance, the auditorium is dark. The emergency lights will not come on because they only respond to power failure. The fire alarm authorities responded by requiring that the house lights come up to full brightness upon receipt of a fire

alarm. Unfortunately, most fire alarms occur when there is not a show in progress. The fire alarm doesn't know – all it knows is that the house lights must come up to full brightness. After several mis-operations of this type, the fire alarm lighting control is disabled.

**Fire alarm drawing notes.** A construction drawing usually requires general notes and keyed notes. The general notes are assumptions made by the designer which should be known to the installer. In addition, problems with previous jobs can be avoided by stating the clarification that came up at that time. Below is a sample set of general notes for a fire alarm riser diagram.

ADDRESSABLE FIRE ALARM SYSTEM TYPICAL RISER

NOTES:

1. THIS RISER REPRESENTS A TYPICAL SYSTEM AND IS NOT INTENDED FOR INSTALLATION. SYSTEM SUPPLIER SHALL PROVIDE INSTALLATION DRAWINGS AND SCHEMATIC WIRING DIAGRAMS. EXACT SYSTEM REQUIREMENTS SHALL BE COORDINATED WITH THE SYSTEM SUPPLIER.
2. SYSTEM SUPPLIER SHALL SUPERVISE INSTALLATION, PROGRAM AND TEST SYSTEM, AND INSTRUCT OWNER ON SYSTEM OPERATION.
3. ALL FIRE ALARM WIRING SHALL BE IN 1/2" CONDUIT. ALL WIRING SHALL BE VERIFIED WITH THE SYSTEM SUPPLIER PRIOR TO BID.
4. PROVIDE ADDITIONAL MONITOR AND CONTROL MODULES AS RECOMMENDED BY THE SYSTEM SUPPLIER.
5. ALL CONTROL CABINETS SHALL BE GROUNDED PER N.E.C. REQUIREMENTS AND SPECIFICATIONS.
6. COORDINATE CITY TIE-IN REQUIREMENTS WITH LOCAL AUTHORITY.
7. REFER TO SPECIFICATIONS SECTION 16721 FOR ADDITIONAL REQUIREMENTS. REFER TO DRAWINGS FOR DEVICE QUANTITY AND LOCATIONS.

There are always questions of style and preference in design. These show up in the notes as well. Note 3, in this case, specifies 1/2-in conduit. Many designers feel that concealed conduits should be minimum 3/4-in diameter EMT or RGS. The increased materials cost is not associated by increased labor and provides capacity for future expansion or accommodation of future technology. The importance of the note is the requirement for conduit; forbidding open wiring (which is very much less expensive).

Another preference and style question is the term "conduit". Contractors and inspectors are beginning to accept flexible non-metallic conduit (Smurf-tube). It has almost no structural strength and the corrugations fight future cable pulls. EMT (thinwall steel tubing) and RGS (heavywall steel pipe) increase the survivability of the fire alarm installation.

Note 6 references "tie-in". Your instructor doesn't know what is meant. There is a requirement, usually ignored, of providing heat detectors and pull stations during construction. There is another requirement often ignored, of hiring a 24/7 monitoring facility for every fire alarm system. There is a requirement for approval by the Fire Department or Building Inspector for the system. I don't know what "tie-in" means.

Keyed notes are usually associated with numbers and a special symbol, as a hex box. Usually, the number in the hex box is on the drawing near something that needs explaining. A list of keyed notes is on the right margin, with each of the explanations.

Keyed notes work very well for busy drawings. However, they add a layer of complication which is avoided by text on the drawing and a leader to the item in question. A problem which arises with notes on the margin is when a job has many sheets or a second sheet is added to a simple job. Do you repeat all keyed notes on the additional pages? If you do not, it makes it hard for the installer who is working in the area not containing the notes on his sheet.

A set of kitchen notes are illustrated below:



## NOTES:

1. THE CONTRACTOR SHALL FURNISH, INSTALL, AND WIRE KITCHEN HOOD LIGHT SWITCH, FAN SWITCH, AND WIRING AMONG PANEL, SWITCHES, AND J-BOX ON THE KITCHEN HOOD. COORDINATE WITH KEC.
2. PROVIDE 120V, 20A CIRCUIT FOR FIRE SUPPRESSION PANEL. ALSO, PROVIDE ANNUNCIATION WIRING BETWEEN BUILDING FIRE ALARM PANEL AND THE KITCHEN HOOD FIRE SUPPRESSION PANEL. PROVIDE OCTAGONAL BACK BOX (54" AFF.) WITH 3/4" CONDUIT RUN 6" INSIDE CEILING. FOR EXACT LOCATION & SIZE COORDINATE WITH KEC.
3. PROVIDE BACK BOXES FOR SOLENOID VALVE AND SWITCH. PROVIDE POWER WIRING/CONDUIT FOR DISPOSER FROM PANEL TO THE J-BOX. COORDINATE WITH KITCHEN CONTRACTOR.
4. FURNISH, INSTALL AND CONNECT DISCONNECT SWITCHES FOR ROLL-IN CONVECTION OVEN WITH ASSOCIATED WIRING CONDUIT BETWEEN PANEL AND THE DISCONNECT SWITCHES.
5. ELECTRICAL CONTRACTOR SHALL PROVIDE SHUNT TRIP BREAKERS FOR COOKING EQUIPMENT UNDER THE HOODS AND FOR HOOD LIGHTS.
6. REPLACE EXISTING PANEL "K" AND WITH NEW PANES KP1. RECONNECT EXISTING CIRCUITS FOR EXISTING EQUIPMENT BEING REPLACED OR REMAINED. EXTEND EXISTING BRANCH CIRCUITS AS REQUIRED IN FIELD.
7. \* - INDICATES EXISTING ROUGH INS TO REMAIN. ELECTRICAL CONTRACTOR SHALL PROTECT EXISTING DEVICES AND ASSOCIATE CONDUITS, WIRING, DISCONNECTS BACK TO FEEDING PANELS. IF FEEDING PANELS ARE BEING DEMOLISHED, THEN ELECTRICAL CONTRACTOR SHALL EXTEND EXISTING BRANCH CIRCUIT TO NEAREST ELECTRICAL PANEL AS REQUIRED IN FIELD. PROVIDE DISCONNECT SWITCH FOR NEW DISHWASHER

Commercial kitchens require special fire suppression and fire alarm equipment. There is an expectation that a fire will occur under the exhaust hood and possibly ignite condensed grease in the exhaust duct. The general form of suppression is a mechanical system where a fusible link releases a valve and a suppressant powder or gas is released. The normal form is for a mechanical pull station to be available to release the valve.

The local Fire Marshall has preferences on automatically turning off the lights under the hood, stopping the fan and cutting off gas and electric appliances under the hood.

The fire alarm system does NOT trip the suppression system. The fire alarm system DOES receive the alarm information from the suppression system. It can be programmed for a local evacuation or building-wide evacuation, at the preference of the Fire Marshall.

Note 2, above, refers to the suppression system telling the fire alarm what is going on. The fire alarm installer must provide a supervised input relay for this purpose. The fire alarm riser should show this connection.

Note 3 refers to a solenoid valve on the fuel gas. This note does not tell the contractor to provide a circuit from the suppression system to the valve and does not identify the power source for the valve.

Note 5 refers to the cut-off of the cooking equipment under the hoods and hood lights. It would be good to identify the power source and the suppression system as the control. Sometimes shunt-trip circuit breakers will not fit in standard power panels. It is the contractor's duty to provide the specified function, but it would be good for the designer to see if an external shunt-trip circuit breaker is required.

**Specifications.** Specifications for fire alarm systems are more fluid than one might suspect. The first variable is which contractor provides and installs the system. The riser notes, above, refer to Specification 16721. This is in Section 16000, Electrical. However, Specification 13851 contains the same title, headings and contents. It is in Section 13000, Special Construction. [It is important to include only one specification for the fire alarm.] A new PDHonline course, E191, "Electrical Construction Specifications", discusses specifying and the new CSI Division 26 for electrical.

The conventional form for a large construction project is for the electrical contractor to run the conduit and wires and install the bases for the sensors and notification devices. The electrical contractor hires a fire alarm installer to do detailed design, get the permits and provide and install the fire alarm control panel and devices. The fire alarm installer is responsible for witnessed tests and documentation (which is substantial).

On a fire alarm renovation project, it is common to bid the jobs to fire alarm installers and let them sub out the pipe and wire installation.

The next level of fluidity in fire alarm specifications is level of detail. It is completely workable and appropriate to specify a fire alarm system in a one-paragraph note on a plan drawing. A sample follows:

CONTRACTOR TO PROVIDE AND INSTALL ADDRESSABLE ANALOG FIRE ALARM SYSTEM, INCLUDING PULL STATIONS, SMOKE DETECTORS, HEAT DETECTORS NOTIFICATION DEVICES, ANNUNCIATOR AT ENTRANCE AND OUTSIDE STROBE AND ALARM BELL. CONTRACTOR TO ARRANGE PERMITS AND INSPECTIONS AND MAKE ANY CHANGES REQUIRED BY AUTHORITY HAVING JURISDICTION - WITHOUT ADDITIONAL COST TO THE OWNER.

Heat detectors are not usually required, so this spec tells the contractor that more than minimal protection is envisioned. If there is no heat detector in the utility room when the designer reviews the submittal drawings, he can justifiably complain that the contractor was informed that heat detectors were required.

The wording "addressable analog" forces the contractor to buy a modern, digital system. The outside strobe and horn are required in some locations and cannot be an extra cost item if this wording is used.

The specific listing of permits, inspections and changes avoids change orders which too often result from a very detailed specification which lacks general language.

For all fire alarms, the Authority Having Jurisdiction makes the final decisions. The wording above helps get the design through plans review at the local building department and helps get a good system installed.

A more detailed, but still clear and fairly short specification is included below:

SECTION 16620

FIRE ALARM / DETECTION SYSTEM

PART 1 GENERAL

1.01 SECTION INCLUDES

- A. Fire alarm system and components

1.02 QUALITY ASSURANCE

- A. NFPA 70 – National Electrical Code
- B. Underwriter's Laboratory

PART 2 PRODUCTS

2.01 MATERIALS

- A. Addressable fully electronic.
- B. Main fire alarm control panel with remote LED display annunciator.
- C. Synchronized strobes.
- D. Non-electronic framed plexiglass annunciator with floor plan and room numbers.

PART 3 EXECUTION

3.01 INSTALLATION

- A. Design and install per NFPA requirements.
- B. Wiring to be installed in conduit.

END OF SECTION

This specification comes from the school design guide published by a state funding commission in the Midwest. The elements thought important enough to be included in this short document are interesting. Section 2 references the National Electric Code without mentioning a year. Different states and communities have adopted different editions of the NEC. I have been told that some townships of some western states do not follow any version of the NEC. It is not clear what this wording contributes. Requiring compliance with the 2002, 2005 or 2008 NEC would be enforceable.

The Section 2 reference to Underwriter's (sic) Laboratory reference is similarly vague. It is important to have a system of components certified to work together. This wording permits sensors and notification devices from one vendor to be connected to a panel from another vendor. The steady-state characteristics of the remote devices are well defined, but the transient characteristics - switching on and off - are not published. Compatibility can only

be determined by test. Notable exceptions are duct smoke detectors and outside weatherproof bells. These components are not made by fire alarm vendors and have a proven record or compatibility.

The Section 2 requirement for LED graphic annunciator is a repudiation of current technology. Twenty years ago, detectors were connected in a group for several rooms or one floor. This was electrically a "zone". Any activated sensor was reported as residing in a particular zone. No further information was available. An alarm for the zone was issued. This matches the idea of a LED being associated with a physical area was easy.

Today, each sensor has a digital address. The fire alarm control panel knows exactly which detector is activated. An alpha display tells, in English, the location of the detector. This is forbidden by the state specification. "Forbidden" is not the correct word. An LED graphic annunciator must be provided and the State will not pay for the alpha display.

The requirement for conduit was discussed in the earlier with reference to notes for riser diagrams.

The third level of detail for a fire alarm specification is a call-out of details of construction for each of the components and wiring methods. This 30-page specification is usually provided by a vendor. It specifies proprietary technology and excludes competitors, even if followed by the words, "or equal".

Surprisingly, long, detailed specifications are used on most major construction projects. The bidders ignore the proprietary detail. The designer ignores the proprietary detail. The construction manager ignores the proprietary detail. The inspector ignores the proprietary detail. A good system is installed, accepted by the inspector and works reliably for 20-years.

**Battery Sizing and Voltage Drop Calculations.** The Code requires that battery selection, wire size selection and count of devices per circuit to be documented with the permit application. The engineering consultant can do this if a single supplier has been selected and the consultant is intimately familiar with the components. Usually, a generic specification is issued and the successful bidder does the calculations and submits them with the permit application.

Vendors have validated spreadsheets and custom software for the calculations.

A reasonable question arises at this point, "Are you sure the spreadsheet does not contain bad formulas and constants?" This comes up right after you read an article on how bad many spreadsheets are. There is no provision in the Code to validate the computations, but an experienced plans reviewer will perform a reasonableness test.

While we are questioning modern technology, we might ask, "Has the software driving this new Fire Alarm Control Unit been validated?" Again, the Code does not directly address this question, but it does distinguish between operating system software and site software. System software is considered the responsibility of the manufacturer. Site software is considered the responsibility of the installer. A copy of the site software must be provided to the Owner, but phone calls to installers suggest that this is honored in breach more than in compliance.

**Authority Having Jurisdiction.** A fire alarm system is purchased by the building owner so that he can get an occupancy permit and move in. The enforcement comes from the Building Standards Department and Building Inspector. The approval may come from a city official, county official, state official or base commanding officer. Until recently, factories interpreted the plant manager to be the person in charge. Gas, electric and communication utilities thought that they had independent authority also.

Today, there is almost always a Building Official (with a license and appointment for this title) who issues the occupancy permit. This person and his staff are the Authority Having Jurisdiction (AHJ). In a locality, there is only one AHJ for fire alarms. There are exceptions, but they are disappearing. Find your local AHJ by asking a fire alarm vendor or electrical contractor.

The significance of the AHJ is that, traditionally, this person can demand changes to meet his preferences. Interpretation of the published Code adopted by the locality can be appealed, but construction is delayed and move-in date is delayed and an important agency is alienated.

**Hard-wired and addressable systems, zones.** The concepts of hard-wired zones and addressable systems were discussed in the specification commentary above. Two additional concepts must be presented. First, zones still have meaning. Fire suppression systems (sprinklers) are inherently hard-piped. When a sprinkler trips, water flows through a monitored valve supplying a moderately large number of sprinkler heads. The valve only knows that something serious happened in the area associated with the piping. It is a zone. The monitored valve reports to the fire alarm control panel that the zone is in alarm. Yes, the valve switch has an address and the control panel knows exactly which valve is reporting, but it does not know which sprinkler head is operating.

For the fire alarm panel to report the sprinkler alarm, it must use zones. Similarly, it is easy to program the computer in the fire alarm panel to group detectors into zones. It can report zones to the LED annunciator, as required by the State specification above.

**Pull stations, enclosures and key operated pull stations. Required pull station locations.** The concept behind pull stations is for residents who are fleeing a fire to notify other residents of the need for evacuation. The first requirement is for pull stations at each exit, with very, very few exceptions.

Owners and Architects often try to avoid extra pull stations. For instance, the Commissioner has a private outside entrance to his office. The Owner will claim that it is not a public exit and does not need the pull station. The designer may note that secretaries in the outer office may be blocked by fire from any exit except through the Commissioner's office. The private entrance has become the main path of egress and certainly should have a pull station to notify the rest of the staff.

A very important topic associated with pull stations is false alarms. Schools now almost universally use clear plastic covers over pull stations. These covers have local battery-operated sounders. Someone who pulls the alarm will set off the sounder and anyone nearby will know exactly where it came from and notice who is running away.

A first reaction to covers on pull stations is that they interfere with timely alarm and evacuation. This is not the attitude of most fire protection professionals. Avoiding false alarms improves occupant confidence and compliance with evacuation signals.

Another variation of pull stations is double-action. A double-action pull requires two conscious efforts to initiate the alarm - as pull down, then out. It was thought earlier that false alarms resulted from inadvertent operation of the pull station. Double-action pulls are still installed, but not emphasized much.

Another solution to false alarms is to remove the pull stations. In very difficult situations such as public housing, the Authority Having Jurisdiction may authorize removing the pull stations if the exit is continuously monitored by security personnel and the rest of the fire alarm system is in full working order. The reasoning is that the guard is paid to watch for people running out the door and will be in a position to request investigation. The guard must have ability to initiate evacuation.

Key-operated pull stations are almost the same thing. The pull station remains, but can be operated only by personnel who have the key.

The course author strongly recommends a pull station at each exit of high fire hazard location, such as kitchens and boiler rooms. You might ask the question, "How does the kitchen Ansul system interact with the building fire alarm system?" Actually, this comes up more often in large computer rooms, with under-floor and people-space discharge of inert gas.

The answer is, "Only slightly". The building fire alarm system must install detectors and notification devices in the computer room, exactly the same as the rest of the building. A local suppression system does not replace the building system. The local suppression system must be installed according to a different set of NFPA documents, but in precise compliance. The suppression system must tell the building system that it has an alarm or has a trouble condition. The building system doesn't have to tell the local suppression system anything.

A more troublesome aspect is the computer HVAC. NFPA 72 says we have to shut down the fan and close any fire or smoke dampers. The suppression standards require the same thing. The IT people don't want to shut down the fans and later restart the computers. What to do?

In fact, the building fire alarm gets built according to plans, with wire for shutting down the fans left near the fan starter. The local suppression system gets built according to plans, with wire for shutting down the fans left near the fan starter. Only a diligent Electrical Inspector or Fire Marshall will get any of the wires hooked up.

In addition to pull station locations within 5-ft of each personnel exit, additional pull stations are required so that no location is more than 200-ft from one. This is usually interpreted as meaning that extremely long hallways require a pull station every 400-ft. Doorway over 40-ft wide, as malls or concert halls, require a pull station on each side.

**Sensors and supervision of sensors. Required sensor locations.** The correct name is initiation devices, which include pull stations, interface relays and smoke and heat detectors.

Smoke detectors are inexpensive and reliable. They work anywhere within their temperature and humidity limits where free of dust and vapors. The temperature limits are (usually) 32-100F and humidity less than 93%. Not for attics or unheated storage spaces. Not for kitchens or locker rooms.

If a design decision or external Code requires smoke detectors, there is a choice of many, many types. One vendor seminar reported that that particular vendor was ceasing to make anything except photoelectric smoke detectors. They couldn't find any application where the basic photoelectric wasn't the best choice. Other salespersons recommend other types of

detectors. The Code leaves the decision to the designer and approval by the Authority Having Jurisdiction.

The rule-of-thumb is to space smoke or heat detectors on 30-ft centers. Stay away from the walls; try to get close to any high spots. Do NOT place the detector at the peak, which tends to be a dead-space. There are a number of detailed rules in the later paraphrasing of the Code sections. A detector must be installed over the fire alarm control panel.

Heat detectors are slower than smoke detectors. They are not first choice except in locations with dust and vapors.

Heat detectors are available in fixed-temperature, rate-of-rise, combination, and analog. The combination fixed-temperature / rate-of-rise heat sensor is, arguably, the best you can buy. The analog sensors report a numeric heat value to the fire alarm control panel and let the computer decide if fixed-temperature, rate-of-rise, or fire signature rules have been met for an alarm.

All initiation device circuits (smoke, heat, pull, interface relay) must be supervised. Normally, this means that a small amount of electric current flows to the end-of-line resistor at all times. If the line is broken (open) the current is reduced and a trouble light comes on. If the line is shorted (crossed), more current flows and the trouble light comes on.

With digital addressable devices, the central panel computer can query each device every few minutes and verify that they are alive and well. The end-of-line resistor and current sensing are no longer required, but the system is still supervised.

**Smoke control.** The 2007 Fire Alarm Code is notably vague regarding smoke control. The hazards are clear: toxic fumes and obscured path of egress. The solution, in previous editions of the Code, was a "Firefighter's Smoke Control Panel (FSCP)." This was not defined, but generally interpreted to mean selector switches to permit the firefighter to selectively turn ON and OFF individual fans and dampers, to pressurize a space to retard fire spread or exhaust fumes and vapors to aid evacuation. There were two very serious problems, as follows. First, the most basic fan control includes a duct smoke detector to disable it when smoke is present. A functional FSCP would have to be able to override the duct smoke detector. Second, considerable knowledge of the HVAC system, register locations and current fire status is necessary to use the selector switches wisely.

The idea of the FSCP remains in the 2007 Code, but it is loosely referenced to NFPA-101, which is not law and all details of operation are worded as optional. The NFPA meaning of "Smoke Control" is more than duct detectors, but it is not well defined, in a regulatory sense, at present.

**Duct Smoke Detectors.** The goal of fire alarms is to save lives. Most deaths result from smoke inhalation, often toxic fumes released by the heat of the fire. It is critical to NOT distribute smoke and toxic fumes from the fire throughout the building. For this reason, smoke detectors are installed on the return air duct of an HVAC system. The reasoning is that this is the point where smoke from the occupied space will be present. The overriding goal is to shut down the fan. A secondary goal is to annunciate to the occupants that a problem exists and evacuation is called for.

The HVAC Codes require smoke detectors on the supply side of large air handlers. The reasoning is that the fan motor or belts may burn up and the system will distribute the fumes to the occupied space. Some HVAC designers require smoke detectors on the ductwork leading to exhaust fans. The fire alarm designer must provide an alarm initiation circuit and

make sure the test/reset control is provided. The reasoning behind smoke detectors on exhaust is unfathomable.

**Specialized detectors, such as beam detectors and UV sensors.** It takes a lot of photoelectric smoke detectors to protect a warehouse. It may take ten or fewer beam detectors. There is no drawback to beam-type smoke detectors, except cost and care required for installation.

UV sensors, also, are very good detectors. Almost all commercial boilers use “purple peepers” to verify the flame. For boilers, the alarm takes place when the flickering is not detected. The same principle works well for well defined fire hazards. Ultraviolet radiation is present in the early stages of some fires. UV is not present in other fires and smoke obscures the UV as it does visible light. With care, the temperature and humidity limitations of photoelectric detectors can be avoided.

An awkward topic will now be identified, but not addressed: new technology. The 2007 Fire Alarm Code specifically accepts new, unproven technology, called, “Performance Based Systems.” There is discussion of detectors sensitive to chemical vapors produced by specific fires and smoldering heaps. Your author has high confidence in primitive hard-wired systems and addressable systems with smoke detectors, heat detectors, pull stations and strobe/horns. He is very slowly accommodating voice-notification systems. New technology is reserved for persons with high risk-tolerance.

**CCTV / Software Smoke and Flame Detection.** The 2007 Fire Alarm Code obliquely references UL-approved “Video Image Smoke Detection” and “Video Image Flame Detection”.

With the current obsession on terrorist events, CCTV (closed circuit television) cameras are being installed in massive numbers. The concept of using these devices for fire warning is attractive.

The only UL-approved Video Image Smoke Detection system commercially available at the time of this course-writing is SigniFire™ by axonX, of Sparks, MD (axonX.com). Selected text from their literature and proposal are included below, followed by discussion.

axonX is pleased to provide the following proposal that will allow the ABC Company to implement an advanced fire safety/security solution to meet the requirements of its warehousing and data center facilities. SigniFire™ is a revolutionary technology that can detect fire and smoke over standard CCTV systems. In addition to providing advanced motion detection and all the other standard features of a Digital Video Recorder (DVR), SigniFire™ will allow all of your standard CCTV cameras to become early warning fire and smoke detectors.

One benefit of this technology is its fast response when compared to standard point detectors such as spot-type smoke alarms or heat sensors. In addition, this early warning is combined with a visual verification feature that allows security personnel to look at the live situation to determine the best course of action. Installing the SigniFire™ system will increase situational awareness, reduce false alarms, better protect property and assets, and provide a safer working environment.



## SigniFire™ FSM-8 Camera System

<b>Includes:</b>	<b>Each</b>	<b>Total</b>
(1) SigniFire™ FSM-8 DVR Capable of monitoring 8 analog cameras	\$16,000	\$16,000
(8) analog cameras FM approved	\$ 400	\$ 3,200
Security officer workstation front/end SpyderGuard™ license		\$ 2,000
System Commissioning/Installation (Plus travel / per diem expenses)		Included

Four points should be noted. First, this is a Windows® XP® personal computer with an 8-camera video-capture card. Video processing is very compute-intensive. Second, mounting, power, cabling, etc are NOT part of the “installation” included. Third, this is an initiation device. Fourth, it is approved by Factory Mutual (FM), not Underwriters Laboratory (UL). FM specializes in property protection. UL specializes in personnel protection.

**Notification devices and supervision. Required notification device locations.** For many years, it was the “fire bell”. Typically a pull station closed a switch and electricity was fed to bells in all the hallways. This worked; it still works, but it is not compliant with current Codes, represented by the Fire Alarm Code.

The Fire Alarm Code does not specify what type of notification device must be used. Bells, horns, speakers, strobes and beacons all work well. The strobe/horn combination is exceedingly economic and was the notification device of choice until recently. Some jurisdictions and State funding commissions are requiring voice notification. It is also required in high-rise apartments, condominiums and some commercial buildings. The strobe/speaker combination is now replacing the strobe/horn. An advantage is that the speaker requires less current for the same alarm loudness, so smaller wire can be used. There is no cost penalty for the new technology.

Notification device circuits must be supervised the same as initiation device circuits.

Notification devices, strobe/horns, etc, must be located within 15-ft of the end of each corridor and not more than 100-ft apart within a corridor. When two or more strobes are visible from a location, they must be synchronized so they flash exactly together.

The current rule-of-thumb for strobe/horn locations is at least one in every public space, as lobbies, meeting rooms, work rooms, classrooms, laboratories, storeroom, factory area or large restroom. For large spaces, one standard strobe/horn (70dBA / 15cd) is needed for each 400 sq-ft of floor space, or 27 sq-ft per cd.

**Hidden Notification Devices.** At least one vendor is offering strobe/horns and strobe/speakers which fit in a box in the ceiling space and drop down when activated. One Fire Marshall stated that he likes them a lot - they are protected from incidental damage and

have an excellent operational record in correctional institutions. Your course author is not recommending these because of 30-years observation of equipment failures and maintenance practices. A mechanical linkage will be painted shut, become inoperable and never be fixed.

**Magnetic Door Hold Opens.** When the Architect is trying to create a building that meets the needs of the Owner and complies with Building Codes, he is encouraged to break the space into closed, individual compartments. Many construction requirements are relaxed or eliminated if compartments are used. Unfortunately, people move around. Large corridors violate the compartmentalization. A solution is fire doors which are normally open, but close in the event of a fire to create the compartments. The device which normally holds the door open is a magnetic door hold open.

Some magnetic door hold opens operate directly off the fire alarm power supply and alarm circuit. Some require a supervised relay and external power. All fail in the door-closed condition.

There is a requirement for magnetic door hold opens to be connected to the area smoke detectors on both sides or a dedicated smoke detector on each side. Some jurisdictions require the dedicated detectors. Recently, there was a small controversy about wall-mounted detectors for magnetic door hold opens. The requirement is that they be on both sides of the corridor because smoke flow sometimes stays on one side only. A single ceiling-mounted detector is adequate, again, because of smoke flow dynamics.

**Fire Shutters.** A fire shutter is the same idea as the magnetic door hold open, except that a motor drives the shutter into the closed position and there is more to go wrong with the fire shutter.

**Magnetic door locks.** The Fire Alarm Code reads that magnetic door locks must release when the fire alarm operates. There is considerable controversy in the Owner and Architect community regarding this requirement. A fire alarm system that does not directly go into evacuation alarm is one solution. The special Code sections and interpretations for prisons, hospitals, public housing and museums provide exceptions.

**Interface devices and supervision.** A supervised remote relay refers to a device that has been UL tested and labeled for use with a particular fire alarm system. It can be an input - as picking up the operation of a kitchen hood fire suppression system, or an output - turning on the outside bell and strobe. Supervision means that a malfunction will trip a trouble circuit and flashing yellow light on the fire alarm console. Modern supervised remote relays have a selectable address and are connected to the digital fire alarm circuit. Formerly, alarm and trouble wire had to be run to the fire alarm panel. Supervised remote relays are available in banks of eight, to accommodate multiple connections, as for elevator control. It is generally not permitted or not economic to provide digital communications between systems.

**Sprinkler system interface.** The supervised flow control valve for a sprinkler system was discussed briefly in the section on zones. There are three parts of the valve monitor for a sprinkler valve - flow, tamper and trouble. Flow is usually a sail switch in the sprinkler line. It must operate when a single sprinkler head draws rated flow. It must survive the entire zone of sprinkler heads operating. The output is an alarm and normally programmed for building evacuation.

The tamper switch is another life-safety monitor. When the sprinkler system is worked on, the flow valve is shut off. (It is usually chained and locked, so that it cannot be shut off

accidentally.) When the valve is off, the sprinklers are inoperative and the building and occupants are at risk. The tamper switch sends a signal to the fire alarm control panel any time the valve is not at the full-open position. It is usually annunciated as a "trouble". The reason for the reduced priority is that the valve may be shut off for hours or days. A fire alarm control panel is not permitted to have a continuing alarm without going into alarm.

True trouble refers to a malfunction of the circuitry of the remote supervised relay. If the relay is disconnected, it is not known that the sprinkler is out of service, but there is some problem and it must be investigated.

**Elevator interface.** The elevator interface to the fire alarm system is not really complicated, but there are many components and forms. The one used must be selected by the Architect and Mechanical Engineer and communicated to the fire alarm specifier and designer. If questions remain, the elevator vendor who is helping the Architect should be consulted. A drawing note requiring coordination between the fire alarm contractor and elevator contractor is strongly recommended.

Some general principles are discussed here. Some, but probably not all, will apply to a particular project - elevator lobby smoke detectors, machine room smoke detectors, machine room heat detectors, pit smoke detectors, shaft smoke detectors, safe floor recall, alternate floor recall, fire alarm connection to elevator controls, elevator power shunt-trip circuit breaker, shutdown supervision, powered smoke damper operation, car alarm, firefighter service indicator ("red Hat").

Before the present level of sophistication, the Elevator Code (ASME A17.1) required dedicated fire alarm systems for the elevator lobbies. In the event of fire, the elevator was forced to return to a safe floor and taken out of public service, but available for firefighters.

At some point in recent history, dual-contact smoke detectors were used for elevator lobbies, so that the building fire alarm system also knew there was a tripped sensor. Evacuation could be selected or some other action. Today, the preferred method is to provide building fire alarm system smoke detectors in the elevator lobbies and have the fire alarm system tell the elevator controls that there is a problem.

Machine room, pit and elevator shaft smoke detectors are required in some installations and forbidden in other installations. Both the Fire Inspector and the Elevator Inspector must approve the installation, so questions should be directed to them. The safe approach is to specify the sensors and disable them in software if not needed.

Machine room and shaft heat detectors are required if sprinkler heads are present. The heat detector is to take the elevator out of service before the sprinkler trips. Elevator power shunt-trip is used with machine room heat detectors when sprinklers are present.

Again, the recommendation of this course is to consult with the Architect and Mechanical Engineer about the requirements and show a generic interface between the fire alarm and elevator controls on the fire alarm riser diagram. Direct the fire alarm installer to coordinate with the elevator installer. If confusion remains regarding smoke detectors, heat detectors and a powered shaft louver, include them and find out at final design coordination.

**Voice notification and public address interface.** Requirements for details of a voice notification system are included in the Fire Alarm Code. Requirement for voice notification comes from the local Building Code. Note that different localities (and different inspectors) have different interpretations and may- or may not require voice notification.

For new installations, voice notification simply means replacing a horn driver card in the panel with a digital voice card. In addition to strobe power supplies, speaker amplifiers must be included. The speaker/strobes cost about the same as horn/strobes. The fire alarm control panel modules cost about the same, but there are more of them. In a large system, providing a speaker amplifier for each zone may require an additional wall cabinet, further increasing the cost and increasing the space required.

Using the fire alarm speakers for public address is always permitted. The Authority Having Jurisdiction (AHJ) views this connection as improving reliability of the system, since failures will be noted and repaired. The limitation is that the connection must be in a form that will not diminish the fire alarm function. A fire alarm interface module from the fire alarm vendor is the only correct method.

The 2007 Fire Alarm Code adds biohazard, terrorist, weather and natural disaster notification to permitted use of fire alarm speakers and places their priority ABOVE fire alarm notification.

Using the public address speakers for fire alarm notification requires more attention. Fire alarm equipment uses supervised circuitry and primary and secondary power supplies. Local AHJ's have approved the use of stadium public address as fire alarm notification. Only the AHJ can authorize this.

**Stand-alone residential smoke alarms and building evacuation fire alarm interface.**

Both requirements and interpretation for residential smoke alarms are changing rapidly. You must check with the local Building Standards department to determine the current needs. A very good system uses 120 VAC power and provides linked detectors/sounders outside each sleeping room, inside each sleeping room, near the kitchen, in the utility room and in any storage room that might provide fuel for a fire.

Battery powered stand-alone smoke detectors are still adequate for many jurisdictions, but have battery problems and may not arouse a sleeper on the other side of a door. Obviously, they do not notify of a fire in a different part of the dwelling.

Note that the Fire Alarm Code requires all residential smoke alarms to be replaced 10-years after date of manufacture.

Modern high-rise apartments are different from individual homes. The high-rise has a huge amount of concrete separating the floors and the apartments. A fire in one kitchen may do damage there and the smoke may be deadly, but damage and hazard, even to next door neighbors is unlikely.

Kitchen fires are very common and usually controlled without major damage. With this in mind, the Fire Alarm Code permits connection from the main building to the residential fire alarm but forbids connection from the residential to the building.

A single-apartment kitchen fire should not cause evacuation of the building.

**The fire alarm control panel and annunciator.** There are a few, simple rules for installation of the fire alarm control panel and annunciator. First, put the panel where it will be noticed and available for reset or maintenance. The panel has a yellow light and sounder for trouble. It is important to notice the trouble light and get repairs.

When an evacuation alarm occurs, genuine or false, the system must be silenced and reset. The panel is the correct place to survey operational displays and operate the unit. It is legal

for a serviceman to lockout a zone or detector which is delivering false alarms. New digital remote annunciators provide limited silence and reset functions.

Language of the Code differentiates between intentional “false” alarms and malfunctions, or “nuisance” alarms.

The fire alarm must have a smoke detector over it (or heat detector if in a vapor-laden space). The fire alarm must be fed by a dedicated power circuit. The circuit breaker in the panel must be painted red, locked in the “ON” position by a listed locking device and labeled “FIRE ALARM CIRCUIT.”

The Code requires an annunciator at a central location, readily available for firefighters. It is permitted to place the main panel near the door and avoid an annunciator entirely. This is not recommended, for reasons of security and maintenance. Rather, a remote annunciator should be placed at the door used by fire fighters. (Most communities have their firefighters visit large or important buildings annually to plan where to park their trucks if needed and to be aware of the locations of ordinary and special hazards.) Your course author recommends a second annunciator in the building maintenance or custodial area, where repair persons enter the building or where the staff person is dispatched from to determine if the alarm is genuine or false.

**Central Monitoring and Underground Facilities.** This course is not addressing central monitoring except to provide a single anecdote. A large Midwestern city undertook a \$15 million security project which included a central monitoring facility. An incidental plan was to eliminate all the monitoring contracts for fire and security alarms. The central monitoring facility was built, but the contracts were continued. The city was told that Homeland Security regulations required that central monitoring facilities be underground with access control and magnetic locks on all entrances.

**Installation requirements.** The Fire Alarm Code has extensive installation requirements. They are not the responsibility of the system designer. For reasons of liability, the designer must not provide detailed instructions or detailed drawings. Please see the PDH Online courses on professional liability to understand the distinction between design and “means and methods”.

The designer must reference the Fire Alarm Code and National Electric Code for installation requirements. These Codes give the detailed information and drawings. Note that the edition of each Code must match that adopted by the locality. They get very testy if you reference a newer code which has deleted a favorite requirement.

**Testing requirements.** Again, testing is critical to a reliable fire alarm system. This stage, too, comes under the installing contractor’s responsibility, not the designer’s. The local AHJ must certify the results, not the designer. Make the reference in the specifications and drawing notes.

**Knox Box.** It is good for fire fighters to be able to enter the building to determine if a fire exists or simply a false alarm. The almost universal solution is a very substantial box at the door. The box contains a door key. The box can be opened by a key carried by the fire fighters. The box can have a tamper switch connected to the security or fire alarm, but this is rare. The brand name is “Knox Box.”

**Common Errors in Fire Alarm Design.** The following is a list of comments by plans Reviewers. Many jurisdictions use a checklist (which they jealously guard). Each problem is followed by a >>comment to avoid the difficulty.

Missing pull stations within 5-ft of exit doors - >>Review the final construction drawing set before it goes out. Architects change their minds and isolated outdoor storage rooms become alternate paths of egress with the addition of an inside door.

Missing duct smoke detectors on large air handlers - >>Get a list from the HVAC designer and check the final plans and schedules before release for bidding. Don't forget the remote test/reset stations.

No smoke detector over fire alarm control panel - >>Put one in, even if it appears excessive.

No strobe-only alarm in every bathroom. >>This is a Federal ADA requirement and has been slow to be recognized by designers and reviewers. If the Architect says, "No," you must get it in writing.

No flow switch on sprinkler zones or outside sprinkler bell. >>Get list from piping designer and check final plans and schedules before release for bidding. Some localities also require a sprinkler or fire alarm outside strobe. Check.

**Initiating Devices** - >>A sketch similar to that below introduces Chapter 5 of the NFPA 72 Fire Alarm Code Handbook. It illustrates the expected behavior of an undisturbed fire at the early stages.

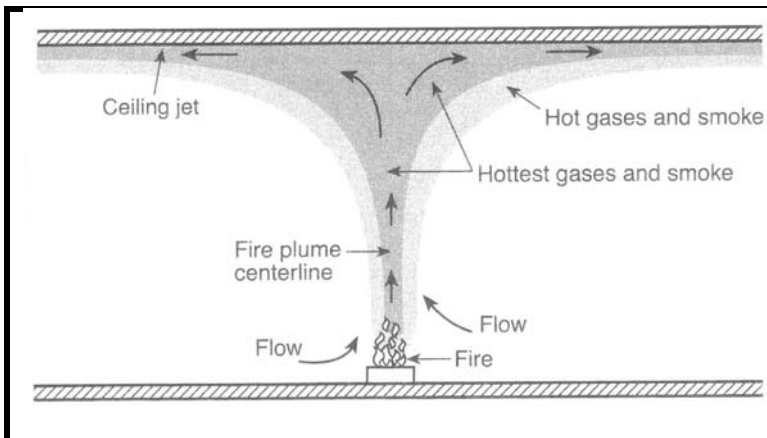

>>The field of fire science is now sufficiently mature that details of fire mechanics under a wide range of environments and influences can be accurately predicted. This sketch is the most simple representation. It is good for conceptual purposes, but lacks the detail available for analysis of real fires under real conditions.

>>The narration in the Fire Alarm Code Handbook makes clear that the Code does not require a fire alarm or a particular form of installation. Local law or interpretation require the fire alarm. The Code tries to force a functional, reliable installation after the decision has been made. For years, the Code body has been trying to remove opportunities for local authority to gut the Code. However, the requirements and enforcement are still local.

**Must support Initiating Devices separately of their Wires** - >>You won't believe how many smoke detectors are temporarily hanging by their wires for years and years. Not legal, but typically, no enforcement exists after acceptance of the original installation. This is also a violation of the National Electrical Code.

**Total Coverage** - all rooms, halls, storage areas, basements, attics, lofts, spaces above suspended ceilings, all accessible spaces including closets, elevator shafts, enclosed stairways, dumbwaiter shafts and chutes.

**Inaccessible Spaces** without combustible materials do not require coverage.

Smoke detectors not required in above-ceiling plenum spaces if duct detectors used and no flammable materials exist in above-ceiling spaces. >>Verify that only plenum-rated data and communications cables will be present.

**Selective Coverage** - if only a portion of the building is protected, then that portion must meet all requirements of the Code. >>Owners are always asking for "just a little" fire protection. If accepted, the "just a little" must be done in full compliance with the Code.

**Heat-Sensing Fire Detectors** - The Handbook lists different technologies and that the Code accepts new technologies that meet the requirements for protection. >>Most common are fixed temp and rate of rise heat detectors.

**Heat Detector Rated Linear Spacing not greater than 50-ft** - >> A later section says to use 30-ft as nominal spacing. This takes care of the natural round pattern of sensitivity and provides a moderate overlap of adjacent detectors.

**Ceiling Heat Detectors not within 4-in of Wall;** Wall Heat Detectors not within 4-in of Ceiling.

**Solid Joist Construction,** Space Heat Detectors at 50% smooth Ceiling Spacing - >>15-ft center-to-center.

**Peaked Ceiling** - Within 3-ft of the peak > but not at the peak.

**Very High Ceilings** - >>At 20-ft height, heat detector spacing should be reduced from 30-ft to 18-ft. At 30-ft height, heat detector spacing should be reduced to 10-ft.

**Smoke Detector Environmental Limits** - Temp: 32-100F; Humidity: below 93%; Air Velocity: below 300 fpm; Altitude: per manufacturer's rating. >>Note that you cannot put smoke detectors where exposed to freezing, high temperature, high humidity or substantial air flow. Contractors often put smoke detectors in attics. This is bad for two reasons - dust causes false alarms and the temp (often 140F) exceeds the limits.

**Ceiling Smoke Detectors not within 4-in of Wall;** Wall Smoke Detectors not within 4-in of Ceiling.

**Smooth Ceiling use 30-ft** nominal smoke detector spacing.

**Joists or Beams less than 12-in,** space smoke detectors same as flat ceiling along beams (30-ft) and one-half flat ceiling across beams (15-ft).

Joists or Beams over 12-in, locate smoke detectors on beams or in every pocket, max 30-ft spacing.

**Air Sampling Smoke Detector** - >>complicated, high-cost, require maintenance, but appropriate for inaccessible locations, if a maintenance program exists.

**Projected Beam Smoke Detectors** located in accordance with manufacturer's instructions - >>Very, very appropriate for large spaces, as warehouses, auditoriums non-dust factories. Will not false trip easily. Sensitive to genuine smoke plume.

**Raised Floors and Suspended Ceilings** are to be treated a Separate Rooms.

Keep **Smoke Detectors** away from **HVAC** Supply or Return Grills.

**Flame Detectors.** - >>Very specialized detectors. Work reliably except when electric arc welders are in field of view.

**Sprinkler Flow Switches** - >>The fire alarm designer confirms that the fire alarm will accept the switch contacts, but the switches, themselves are purchased and installed by the piping contractor. Problems arise when the piping designer isn't familiar with the Sprinkler Code. The Fire Alarm designer must coordinate.

**Detection of Other Suppression Systems** - Flow or water in foam systems; pump activation, pressure, mechanical release. Provide in accordance with manufacturer's instructions. >>Again, this is a coordination issue with the kitchen equipment supplier and the piping designer.

**Pull Stations** - Throughout the protected area so that they are conspicuous, unobstructed, and accessible. >>Many persons, including some fire alarm designers think that pull stations are required only at the exit doors. They are required in school hallways, in kitchens and in places where a reasonable likelihood of fire exists.

>>The Handbook discussion of this section specifically authorizes use of plastic covers and covers with sounders to reduce false alarms.

**Pull stations must be within 5-ft of exit** doorways on each floor.

Pull stations must be on both sides of doors more than 40-ft wide.

**Pull stations not more than 200-ft** spacing on any floor. >>Remember, this requirement only applies in specific types of construction and use groups. Stores are usually excluded.

### **Sprinkler Valve Tamper Switches**

Pressure Switch Off-Normal and Return-to-Normal

**Smoke Detectors for Smoke Control** - >>There is an effort to provide smoke control for fire fighters. This section offers optional smoke detectors to report to the control location on the effects of manually starting and stopping fans and opening and closing HVAC dampers.

**Duct Smoke Detectors** - Other Codes require the detectors and specify their locations. This Code specifies details of construction and installation details. >>The HVAC designer is



responsible for locating duct detectors. The fire alarm designer does this only when there is a retrofit of a fire alarm to an old building that did not have duct detectors. It is essential to work closely with an HVAC designer familiar with the HVAC Codes for the community.

>>Duct detectors are very, very similar to standard smoke detectors, with three exceptions. First, the duct detector uses a sampling tube to provide a low-velocity flow of air, within the fpm specs of the detector.

>>Second, an old-style duct detector has two alarm contacts - one to directly shut down the fan and another to alarm to the central system. Fire alarm vendors now prefer an addressable detector and a supervised relay to shut down the fan. This accommodates smoke control through the fire alarm.

>>Third, a duct smoke detector requires a manual test/reset station if the detector location is inaccessible. This is an old requirement, but is presently being enforced.

**Smoke Detectors in Door Release Service** - Either area smoke detectors or dedicated door smoke detectors may be used. >>Area smoke detectors perform the function via programming in the fire alarm control panel. Dedicated smoke detectors, on both sides of the door, must have contacts rated for the voltage and current of the door-hold electromagnet. Connection of dedicated detectors to the general fire alarm system is optional.

Fire Alarm must report to **in-house central monitor or commercial central monitor**.

**Evacuation is not a required** output - >>It is common in high-rise buildings to evacuate only the affected floor and the floors above and below. Hospitals and prisons generally do not evacuate.

**Computerized Fire Alarms** must have restricted access for changes - Four levels are shown for an example.

**Nonrequired systems** shall meet the requirements of this Code.

**Required features** - One or more of the following: 1. Pull stations; 2. Automatic alarm signal initiation; 3. Trouble notification from fire suppression systems; 4. Activation of suppression systems; 5. Activation of fire safety functions (elevator recall, fan shutdown); 6. Activation of alarm notification appliances; 7. Emergency voice/alarm communications; 8. Guard's tour supervisory service; 9. Process monitoring supervision (refrigeration failure); 10. Activation of off-premises signals; 11. Combination systems; 12. Integrated systems.

**Notification shall occur within 10-seconds** of activation of the initiating device. ->>There are very limited exceptions to this

**Presignal** - The fire alarm sounds to a control room. The operator can initiate evacuation or abort the alarm. If no action is taken within 60-seconds, the fire alarm automatically signals evacuation.

**Alarm Verification** - Two sensors or one sensor, which is reset and trips again within 60-seconds.

**Positive Alarm Sequence** - Permits operator 180-seconds to investigate the cause of an alarm.

**Connecting two Fire Alarm Systems together** - >>This is often required for an addition to an existing building. Each unit must support alarm, supervision and trouble features. Units may be connected as zones or just trip the overall alarm.

The 1999 Fire Alarm Code had extended discussion of Data Gathering Panels. These are limited-function fire alarm panels for an area, floor or building. When connected to the main fire alarm panel, they report addressable device information and offer selective evacuation. In the event of loss of communication with the main fire alarm panel, they respond to any initiation device with a full evacuation of their area, floor or building. This concept is especially appropriate for phased construction, where individual areas are taken off the main panel and temporary construction fire alarm is used. Then, the final fire alarm is activated after construction.

**Silence and Reset** normally cannot be remotely performed. Exceptions may be granted by the Authority Having Jurisdiction.

Building fire alarm may trip dwelling unit alarm; **Dwelling unit may not trip building.**

**Combination of Fire Alarm with Other Systems** - >>Virtually anything can be combined with a fire alarm system as long as it does not interfere with the operation of the fire alarm system. Note 2007 change that biohazard, terrorists, weather and natural disasters may take precedence over fire alarm.

>>Owners and salesmen quote this section to buy cheaper equipment to replace the fire alarm - such as a plant SCADA system or auditorium PA system. The fire alarm must be 100% fire alarm, supervised, UL-listed for life-safety, two power sources, etc. Other equipment may be connected to it, but not replace it. The connection must be of a form that cannot interfere with the fire alarm system in any conceivable failure mode.

**Drift Compensation on Smoke Detectors** - >>Addressable analog systems report the numeric value of the smoke detected. The background level changes over time, due to component aging and environmental changes. A smart addressable analog system is permitted to compensate out gradual changes, up to a limit.

**Fire Pump Supervision** - >>The fire pump is normally specified by the piping designer. Close coordination is required to inform the fire alarm of the different trouble and alarm modes.

**Notification Zones** - Provide notification zones to match the evacuation plan of the building. >>See the course discussion of zones.

**Emergency Voice / Alarm Communications** - Recorded messages specific to the building are required. Multiple, distinct messages are permitted for partial evacuation. Live announcements and instructions from firefighters shall be available.

The Fire Alarm Code does not require voice notification. If the local interpretation of the Building Code requires it, though, it must be installed according to the Fire Alarm Code.

**Fire Command Center** - The fire command center houses the fire alarm control panel and voice notification microphone and fire telephone, if present.

**Elevator Recall for Fire Fighters' Service** - >>see the text discussion of elevator protection and control.

**Circuit Diagram for Elevator Shunt-Trip Circuit Breaker - >>similar to the following:**

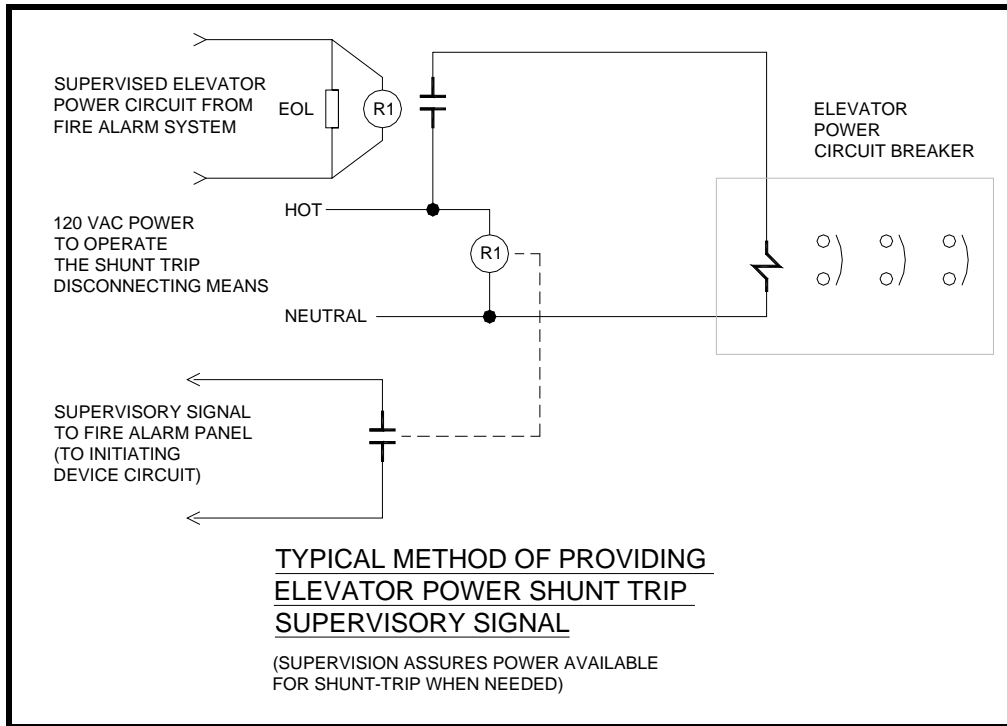

**Door Unlocking Devices** - Locked doors must be connected to the fire alarm system to permit evacuation except when permitted by the Authority Having Jurisdiction. The fire alarm battery shall not be used to keep doors locked. >>This requirement is not widely known. Several problems exist. Since permission is possible to avoid the requirement, many persons simply do not ever see the requirement installed and enforced. Second, when the requirement is applied, residents use the fire alarm to let in friends and strangers and bypass security procedures.

**Audible Notification Loudness** 15 dB above Ambient.

Notification Device Loudness shall not exceed 120dBA (OSHA limit) - Visual notification required where ambient is above 105 dBA. >>**75dBA is a standard** audible notification device

**Private Mode** - Horns in restrooms and hospitals may be rated 45dBA.

**Location of Horns** - Wall mount: 80-96-in above finished floor. Ceiling mount permitted.

**Location of Strobes** - Wall mount: 80-96-in above finished floor unless accompanied by engineering calculations.

**Strobe Brightness** - 15 – 1000 cd (effective candella)

**Strobe Brightness** - one 15-cd strobe per 400-sq ft, not more than 40-ft center-to-center.

**Strobe within 15-ft of end of corridor;** max 100-ft between strobes

**177-cd strobe in sleeping area**

**Standard Graphic Icons** - >>The following is based upon the Code table:

FIRE		STANDPIPE		STAIRWELL PRESSURIZATION	
HEAT DETECTOR		FIRE DEPARTMENT CONNECTION		ELEVATORS	
SMOKE DETECTOR		EMERGENCY SHUTOFF		SECURITY CAMERAS	
GAS DETECTOR		PAGING ZONE		ENERGY MANAGEMENT	
MANUAL PULL STATION		EMERGENCY PHONE		POWER MONITORING	
ALARM SOUNDING		ALL CALL		AUTOMATIC UNLOCKING EGRESS DOORS	
ALARM SILENCED		SMOKE CONTROL FANS		ELECTRICAL ROOM	
SPRINKLER WATERFLOW		SMOKE VENTS		HAZARDOUS MATERIALS STORAGE	

Each icon has a normal meaning, as shown; an active meaning, usually a different color or flashing; and a trouble or fault meaning, usually yellow.

**This concludes the content portion of the course; Close this window to return to Internet reference links.**