



PDHonline Course M143 (4 PDH)

A Basic Design Guide for Clean Room Applications

Instructor: A. Bhatia, B.E.

2012

PDH Online | PDH Center

5272 Meadow Estates Drive
Fairfax, VA 22030-6658
Phone & Fax: 703-988-0088
www.PDHonline.org
www.PDHcenter.com

An Approved Continuing Education Provider

A Basic Design Guide for Clean Room Applications

Course Content

PART – I OVERVIEW

Clean rooms are defined as specially constructed, environmentally controlled enclosed spaces with respect to airborne particulates, temperature, humidity, air pressure, airflow patterns, air motion, vibration, noise, viable (living) organisms, and lighting. Particulate control includes:

- Particulate and microbial contamination
- Particulate concentration and dispersion

“Federal Standard 209E” defines a clean room as a room in which the concentration of airborne particles is controlled to specified limits.

“British Standard 5295” defines a clean room as a room with control of particulate contamination, constructed and used in such a way as to minimize the introduction, generation and retention of particles inside the room and in which the temperature, humidity, airflow patterns, air motion and pressure are controlled.

Today, many manufacturing processes require that spaces be designed to control particulate and microbial contamination while maintaining reasonable installation and operating costs. Clean rooms are typically used in manufacturing, packaging, and research facilities associated with these industries:

1. *Semiconductor*: This industry drives the state of the art clean room design, and this industry accounts for a significant number of all operating clean rooms.
2. *Pharmaceutical*: Clean rooms control living particles that would produce undesirable bacterial growth in the preparation of biological, pharmaceutical, and other medical products as well as in genetic engineering research.

3. *Aerospace*: The manufacturing and assembling of aerospace electronics, missiles and satellites were the first application of clean rooms. Large volume clean room spaces with extreme cleanliness are involved.
4. *Miscellaneous Applications*: Other uses include advanced materials research, laser and optic industries, microelectronics facility, paint room and in some aseptic foods production. Also in some high infection risk areas of hospitals.

While hospital operating rooms can be considered clean spaces, their concern is to control types of contamination rather than the quantity of particles present. The semiconductor manufacturing requires very clean environment.

Sources of contamination

The source of the contamination is categorized as external sources and internal sources.

- A. External Sources - For any given space, there exists the external influence of gross atmospheric contamination. External contamination is brought in primarily through the air conditioning system through makeup air. Also, external contamination can infiltrate through building doors, windows, cracks, and wall penetrations for pipes, cables and ducts. The external contamination is controlled primarily by
 1. High efficiency filtration,
 2. Space pressurization and
 3. Sealing of space penetrations
- B. Internal Sources- The potentially largest source is from people in the clean room, plus shedding of surfaces, process equipment and the process itself. People in the workspace generate particles in the form of skin flakes, lint, cosmetics, and respiratory emissions. Industry generates particles from combustion processes, chemical vapors, soldering fumes, and cleaning agents. Other sources of internal contamination are generated through the activity in combustion, chemical, and manufacturing processes. The size of

these particles ranges from 0.001 to several hundred microns. Particles larger than 5 microns tend to settle quickly unless air blown. The greatest concern is that the actual particle deposits on the product.

Control is primarily through airflow design. Although airflow design is critical, it alone does not guarantee that clean room conditions will be met. Construction finishes; personnel and garments; materials and equipments are sources of particulate contamination that must be controlled. Important control precautions include:

1. Walls, floors, ceiling tiles, lighting fixtures, doors, and windows are construction materials that must be carefully selected to meet clean room standards.
2. People must wear garments to minimize the release of particles into the space. The type of garments depends on the level of cleanliness required by a process. Smocks, coveralls, gloves, and head and shoe covers are clothing accessories commonly used in clean spaces.
3. Materials and equipment must be cleaned before entering the clean room.
4. Room entrances such as air locks and pass-through are used to maintain pressure differentials and reduce contaminants.
5. Air showers are used to remove contaminants from personnel before entering the clean space.

Application Guidelines

The industry differentiates between the cleanliness of rooms by referring to class numbers. Federal Standard 209E, "*Airborne Particulate Cleanliness Classes in Clean Rooms and Clean Zones*", September 11, 1992, categorize clean rooms in six general classes, depending on the particle count (particles per cubic foot) and size in microns (μm). The first three classes allow no particles exceeding 0.5 microns (μm), and the last three allowing some particles up to 5.0 microns.

Clean Room Class	Class Limits "not to exceed" particles per cu ft for particle sizes shown				
	0.1µm	0.2µm	0.3µm	0.5µm	5 µm
1	35.0	7.50	3.0	1.0	--
10	350	75.0	30.0	10.0	--
100	--	750	300	100	--
1000	--	--	--	1000	7.0
10000	--	--	--	10000	70.0
100000	--	--	--	100000	700

Interpreting the table above, a class 100,000 clean room limits the concentration of airborne particles equal to or greater than 0.5 microns to 1 00,000 particles in a cubic foot of air.

ISO/TC209 clean room class ratings are slowly replacing the Federal Standard 209E ratings. ISO/TC209 is based on metric measurements whereas Federal Standard 209E that is based on imperial measurements. The classes, according to ISO/TC209 14644-1, are in terms of class levels 3, 4, 5...of airborne particulate cleanliness. A Class 5 means that less than 3,520 particles (0.5 microns in size) are present per cubic meter, which equals 100 particles per cubic foot. A Class 6 indicates less than 35,200 particles per cubic meter. The higher the class number, the more are the particles present.

Federal Std. 209 E	ISO
1	3
10	4
100	5
1000	6
10000	7
100000	8

Important Regulatory and Guideline Information

1. The Institute of Environmental Sciences (IES): Consideration for Clean room Design, IES - RP - CC012.1
 2. Testing Clean Rooms (IES-RP-CC-006-84-T), outlines performance tests procedures. IES-CC-011-85T for Glossary of terms and definitions related to contamination control.
 3. IES - RP - CC - 006: Testing Clean rooms
 4. IES - RP - CC007: Testing ULPA Filters
 5. Fed Std. 209E: Prepared by the Institute for Environmental Sciences, under the authority of the General Services Administration of the Federal Government offers specific guidelines in terms of non-viable particulate levels.
 6. Chapter 32 of ASHRAE Guide and data book on Systems and Application, 1997 provides information on Clean Spaces.
 7. ISO / TC 209: Clean room and Associated Controlled Environments
 8. JIS - B - 9920: Measuring Methods for Airborne Particles in Clean rooms and Evaluating Methods for Air Cleanliness of Clean rooms; Japanese Standards Association.
 9. NEBB, Procedural Standards for Certified Testing of Clean rooms (refer part III section 4 for details)
-

Terminology

As-build - A clean room that is complete and ready for operation, with all services connected and functional, but without production equipment or personnel in the room.

Operational - A term used to describe a clean room in normal operation with all services functioning and with production equipment and personnel present and performing their normal work functions.

Class - The term used to specify the clean room airborne particulate cleanliness level per FS209 as 1, 10, 100, 1,000, 10,000, and 100,000 (particles per cubic foot).

Important Design Considerations for HVAC Systems

The 4 important air-conditioning design considerations for clean room system design are:

1. Supplying airflow in sufficient volume and cleanliness to support the cleanliness rating of the room.
2. Introducing air in a manner to prevent stagnant areas where particles could accumulate.
3. Conditioning air to meet clean-room temperature, humidity and filtration requirements.
4. Ensuring enough conditioned makeup air to maintain the specified positive pressurization.

Besides the room preparation in terms of materials and finishes play an equally important role in meeting these requirements. The idea is to minimize the internal generation of contaminants from the surfaces.

What differentiates clean room HVAC to conventional systems?

Clean room design encompasses much more than traditional temperature and humidity control. Design must consider aspects such as control of particulate, microbial, electrostatic discharge, gaseous contaminants, airflow pattern control, and pressurization and industrial engineering aspects.

The primary design goal of clean room is the particulate control

The size of these particles ranges from 0.001 to several hundred microns.

Particles of different sizes behave differently as air moves through a room. For example, in an eight-foot high room, a particle in the 50-micron range might take 60 seconds to settle, while a 1-micron particle might take 15 hours to settle. Particles larger than 5 microns tend to settle quickly unless air blown.

A clean room differs from an ordinary ventilated/conditioned room mainly in three ways.

1. Increased air supply: The increased air supply is an important aspect of particle control. Normal air-conditioning systems are designed for 0.5 to 2 air changes per hour essentially based on the occupancy level or as determined from the building exhaust levels. A clean room would have at least 10 air changes per hour and could be as high as 600 for absolute cleanliness. The large air supply is mainly provided to eliminate the settling of the particulate and dilute contamination produced in the room to an acceptable concentration level.
2. The use of high efficiency filters: High efficiency filters are used to filter the supply air into a clean room to ensure the removal of small particles. The high efficiency filters used in clean rooms are installed at the point of air discharge into the room. Room pressurization is mainly provided to ensure that untreated air does not pass from dirtier adjacent areas into the clean room.
3. Room pressurization: The clean room is positively pressurized with respect to the adjacent areas. This is done by supplying more air and extracting less air from the room than is supplied to it.

The greatest concern is that the actual particle deposits on the product, which can spoil it.

Before any methods of contamination control of airborne particles can be applied, a decision must be made as to how critical this particulate matter is to the process or product. This is done by classification of room to requisite class level.

There is much more than above for instance the type of filtration, efficiency, airflow distribution and patterns, amount of pressurization, redundancy, noise issues etc...etc...

We shall discuss the above further in Part II.

PART – II HVAC DESIGN CONSIDERATIONS

1 FILTRATION (HEPA and ULPA Air Filters)

Filtration is an important aspect of clean rooms. Most filters are defined by their particle removal efficiency and airflow rate. Clean rooms require very high efficiency filters and for class 100 and below, 100% HEPA filter coverage is recommended. HEPA (High efficiency particulate arrestance) filtration is 40% more efficient than the highest efficiency rated ASHRAE filter.

Clean room air filtration technology centers around two types:

- High efficiency particulate air (HEPA):

HEPA filters are replaceable extended-media dry-type having a minimum particle collective efficiency of 99.97 to 99.997% for a 0.3 micron particle, and a maximum clean filter pressure drop of 2.54 cm (1") water gauge when tested at rated air flow capacity. 0.3 micron is 1/75,000 of an inch or 1/300, the diameter of the human hair.

- Ultra low penetration air (ULPA):

Most ULPA filters are replaceable extended media dry filters that have a minimum particle collection efficiency of 99.9997 % efficient for particles greater than or equal to 0.12-micron in size.

The high efficiency filters belong to the 'interception' family of filters and are referred to as 'absolute' super interceptor. Absolute filters are used only where an extremely high level of cleanliness or purity is required. Both HEPA & ULPA types fall in this category.

Typically absolute filters use glass fiber paper technology and are generally constructed in deep pleats with aluminum, coated-string or fiber paper pleating separators. They vary in depth from 2 to 12 inches or more.

Filtration Mechanisms

There are four basic mechanisms in which fibrous air filters remove contamination from the airstreams.

1. **Straining or Sieving**: Particles larger than the clearances between fibers cannot pass through and are collected on the media.
2. **Inertial or Impaction**: Particles due to their inertia leave the airstream's around filters and impact the fiber directly. Adhesives usually retain the particles.
3. **Interception**: Particles small enough follow the airstreams line around the filter fiber but are intercepted by the fiber due to the dimensions of the fiber and the particle.
4. **Diffusion**: Particles are small enough and have sufficiently low mass so that air molecules, which are continually in motion and are bombarding the particle, cause the particle to acquire a vibration mode. Because of this vibration mode, the particles have a good chance of coming in contact with the fibers. The smaller the particle, the stronger this effect is. For large particles, over one micron in diameter, this filtration mechanism has virtually no effect.

In the order list above, the mechanisms are increasingly important for decreasing particle sizes. The most critical areas lie between interception and diffusion.

All air-handling systems serving clean room areas are provided with pre-filters to remove gross contamination and protect the cooling coil and final filter from environmental conditions. The pre-filters have a lower efficiency than the one they protect. System employing outside air and return air should have an additional filter of 95% (ASHARE) minimum efficiency. 100% make up air systems supplying air to clean areas should have HEPA filters on the fan discharge and 95% bag filters on the inlet.

Both HEPA and ULPA filters are housed in units known as 'Filter Modules'. The filter module units are mounted into clean room ceilings, walls or workstation benches. Room lighting is often incorporated into ceiling filter modules. Filter modules are perfectly sealed to prevent contamination. Absolute filters must be handled and installed with the greatest care by trained

personnel. Incorrect handling and installation is often the cause of leakage in new filters. The filter housing must be compatible with the filter assembly.

Supplementary means such as 'ultraviolet germicidal irradiation' (UVGI) can be used to supplement HEPA and ULPA air filters. However, the application of UVGI is somewhat limited due to dust accumulation and a gradual loss of capacity with age. UVGI alone should not be substituted for HEPA filters in ducts that discharge air from isolation rooms into general ventilation.

Gas phase filtration such as activated carbon often in conjunction with alumina impregnated with potassium permanganate chemical filters should be employed where called for to assure removal of odor, hazardous & corrosive gases, occupant safety and to protect vital process equipment.

Filter Effectiveness

The ability of a filter to remove particles from the air is reflected by its efficiency rating. The American Society of Heating, Refrigerating, and Air Conditioning Engineers (ASHRAE) has developed a standard for measuring filter effectiveness. The standard describes test procedures to classify filters in terms of arrestance and efficiency. Two terms are commonly used.

- **Arrestance** is the amount of dust removed by the filter, usually represented as a percentage. Since large particles make up most of the weight in an air sample, a filter could remove a fairly high percentage of those particles while having no effect on the numerous small particles in the sample. Thus, filters with an arrestance of 90 percent have little application in clean rooms.
- **Efficiency** measures the ability of the filter to remove the fine particles. ASHRAE efficiencies of between 10 percent and 40 percent should remove 20 percent to 40 percent of the 1-micron particles in the air, but hardly any of the 0.3 to 0.5-micron particles. ASHRAE efficiencies of 80 percent to 95 percent can remove 50 percent to 70 percent of the 0.3-micron particles.

The text information for instance on the efficiency @ 99.97% and 99.997% of HEPA filters look similar but in reality the difference is not insignificant. A 99.97% efficient filter has a fractional penetration of 0.0003; while a 99.99% filter's fractional penetration is 0.0001. This means that a 99.99% filter is *three times more efficient* in removing 0.3-micron particles.

Filter Testing

Absolute filter testing has evolved over the years to accommodate the needs of the various applications in which they are used. Typically the filters are shop tested and only provide the quality certification for required efficiency to the end user.

The efficiency of filter is of paramount importance and must be measured in an appropriate way:

The common five method of filter testing include:

1. **DOP Testing:** A synthetic contaminant often used to test high efficiency filters is composed of atomized droplets of hot di-octyl-phthalate (DOP). High efficiency filters used in clean rooms are subjected to a DOP penetration test to determine the percentage of particles passing through the filter.

DOP has a fairly consistent average particle size of about 0.2 to 0.3 microns. The penetration or efficiency of a filter is strongly affected by the particle size of the challenging aerosol. A small change in particle size can have a significant effect on penetration. The smaller the particle, the lower the efficiency until the maximum penetrating particle size is reached.

Penetration is also affected by airflow rate. The greater the airflow rate, the greater is the penetration.

2. **Leak Testing:** The Federal Standard 209 defines leak as a hole, which would produce a local penetration of 0.1% on photometer with an upstream concentration of 100% and sampling of 1 CFM with the air flowing through the filter at a face velocity of 90FPM. Typically 'cold DOP' is used for leak testing. Every square inch of filter surface and its

gaskets and framing system are scanned for leaks using 1CFM sampling rate, 90 FPM face velocity and the 0.01% penetration level as a leak.

3. **Two Flow Testing:** Two-flow testing is different than that defined by Federal Standard 209 and is actually specified in Mil Std. F-51068E. A filter passing this test is almost as good as a scanned filter. The customers who want to be sure that the filters have the required efficiency but do not need leak free filters use the two-flow test. In two flow test the filter is challenged by hot DOP at 100% of rated flow and also challenged @ 20% of rated flow. The 100% test measures the filter efficiency whereas the 20% flow test measures the penetration at the lower flow and indicates the presence of leaks.
4. **Scan Testing:** The scan test is used solely as a leak test and is applied only to Absolute filters which have already passed the DOP efficiency test and have a penetration of less than 0.03%. This test not only measures individual leaks but locates them as well. Cold DOP smoke is used in the scan test.
5. **Laser Testing:** Standard tests of filters using photometers to measure efficiency and to scan for pinhole leaks while still valuable, do not provide detailed information on specific particle sizes. Laser based electronic particle spectrometers capable of counting and sizing particles in very small discrete size ranges are applied to the requirements of micro-electronic industry.

In general, certification and testing of HEPA filters includes leak testing, scanning, electrical testing, particle count surveys, sound level measurement, vibration measurement, temperature and humidity measurement, airflow balancing, gas system testing, and light level measurement.

Filtration - Airborne Molecular Contamination Control

There is another type of airborne contamination that is not controlled with traditional clean room filtration technology. This is non-particulate, or molecular, contamination.

The term airborne molecular contamination (AMC) covers a wide range of chemical contaminants that can be present in clean room air. AMC can be in the form of gases, vapors or aerosols that

be the result of outdoor air, manufacturing processes, fugitive emissions from process equipment and chemical supply lines, cross-contamination between manufacturing areas, chemical storage areas, off-gassing from building and construction materials, accidental spills, and bio-effluents from clean room personnel.

AMC can be detrimental to manufacturing processes and products and also can represent considerable health hazards to personnel. AMC may be toxic, corrosive, irritant or odorous.

Major design considerations are:

Incorporate gas phase chemical filtration systems or dry scrubbing systems into design. These can be easily integrated into existing air handling equipment for toxic and odor gas control.

AMC control can be applied a couple of ways in a clean room. The first could be to treat only the outdoor air—if the outdoor air is a primary concern. Makeup air systems must typically be designed to control SO_x, NO_x, ozone, VOCs, and some site-specific contaminants such as chlorine, organophosphates, and ammonia.

The second application would be to treat the mixed air stream (outdoor + re-circulation air). Chemical filtration equipment in re-circulation systems must be designed to remove a wide array of acids, bases, hydrocarbons, and other VOCs that are the result of manufacturing process emissions. Re-circulation air systems require that AMC control be chosen based on functional area requirements.

A properly designed, installed, and maintained gaseous air cleaning system will be able to effectively and economically remove essentially all chemical contaminants of concern from the clean room environment.

2 AIRFLOW DISTRIBUTION AND CONTROL

Depending on the degree of cleanliness required, it is common for air systems to deliver considerably more air than would be needed solely to meet temperature and humidity design. Airborne particles can be organic or inorganic. Most contamination control problems concern the total contamination within the air.

Particles of different sizes behave differently as air moves through a room. Selection of the airflow patterns is a major step in clean room design. Because airflow is such an important aspect of particle control, the design of a clean room requires careful consideration of air motion and airflow patterns. The general air patterns are:

- **Unidirectional** (*sometimes referred as laminar flow*) is an airflow pattern in which essentially the entire body of air within a confined area moves with uniform velocity and in single direction with generally parallel airstreams. Clean rooms; class 100 and below have unidirectional airflow pattern.
 - **Non-unidirectional airflow** is not unidirectional by having a varying velocity, multiple pass circulation or nonparallel flow direction. Conventional flow clean rooms (class 1000 & 10000) have non-unidirectional or mixed air flow patterns.
 - **Mixed patterns** combine some of each flow type.
-

What are the common practices of clean room design?

Clean room airflow design conventionally follows the table below to decide on the airflow pattern, average velocities and air changes per hour. One has to first identify the level of cleanliness required and apply the table below. Please note that there is no scientific or statutory basis for this inference other than the explanation that the table is derived from experience over past two decades.

Clean room Class	Airflow Type	Av. Airflow Velocity, fpm	Air changes/hr
1	Unidirectional	70-100	350-650
10	Unidirectional	60-110	300-600
100	Unidirectional	50-90	300-480
1,000	Mixed	40-90	150-250
10,000	Mixed	25-40	60-120
100,000	Mixed	10-30	10-40

List the specific design features of unidirectional airflow design?

Unidirectional airflow pattern is a requirement for absolute cleanliness and is conventionally applied to spaces demanding class 100 levels or below. *The principle underlying cleanliness for unidirectional airflow pattern is the air velocity. Higher air velocity is advantageous in particle removal/settlement.*

IES Standard RP CC 002-86 "Laminar Flow Clean Air Devices" defines the level of acceptance for velocity, as "Average measured clean air velocity should be 90 FPM. All measured values should fall within plus or minus 20% of the measured average.

The common approach in designing a unidirectional airflow clean room is to simply fix the filter velocity at 90 fpm and then specify different ceiling coverage percentages for different classification levels.

Why 90 FPM?

The definition of "Laminar Flow", 90 FPM plus or minus 20% does not exist officially. As a common industry practice, manufacturers and designers design the systems at this velocity. The

primary purpose is to provide adequate air at a velocity to keep airflow straight in unidirectional that can efficiently dilute and carry away particles or contaminants generated within the room.

The high velocities may not be efficient and may result in over design that may be very energy inefficient. There is nothing called set velocity; the 90 fpm velocity is just a widely accepted practice that shall differ with the type of filtration and type of air handling equipment. Therefore while designing a clean room it is imperative that the designer and the end user agree as to what constitutes the design velocities for the specific project.

In an empty room with no obstructions to the airflow, even the air velocities lower than 90 FPM shall remove contamination much faster. Though in practical situations there are obstructions and people moving in the space. Obstructions will cause the laminar airflow to be turned into turbulent airflow around the obstructions.

What differentiates unidirectional to the non-unidirectional flow design?

Clean rooms have evolved into two major types, which are differentiated by their method of ventilation - turbulent airflow and unidirectional (laminar) airflow clean rooms. The general method of ventilation used in turbulent airflow clean rooms is similar to that found in buildings such as offices, schools, malls, manufacturing plants, auditoriums, shops, etc. The air is supplied by an air conditioning system through diffusers in the ceiling. The laminar flow on the other hand has stringent guidelines. Let's check this out further.

1. Unidirectional airflow pattern is in one direction, usually horizontal or vertical at a uniform speed of between 60 to 90 FPM throughout the entire space. The air velocity is sufficient to remove particles before they settle onto surfaces. The non-unidirectional turbulent airflow ventilation system relies on mixing and dilution to remove contamination.
2. Unidirectional airflow tends to remain parallel (or within 18 degrees of parallel) until it encounters obstacles such as people, process equipment and workbenches where it tends to become turbulent. Use of workstations with perforated tabletops allows the air to

- pass through them uninterrupted. Turbulent areas can have countercurrents of higher velocity, reverse flow or even stagnant or no flow. Small clusters of particles can cluster in stagnant areas and finally settle on the product.
3. Unidirectional airflow is used when low airborne concentrations of particles or bacteria are present. Non-unidirectional flow is used where particle sizes are relatively large.
 4. Air changes per unit of time are related to the volume of the room and are many times greater in unidirectional flow design than those supplied to a turbulent airflow clean room.
 5. The non-unidirectional or mixed air flow patterns differ in the location of the supply and return air registers and air filter locations. In non-unidirectional arrangement, the airflow is typically supplied through diffusers with HEPA filters in them, or in the ductwork or air handler. Unidirectional airflow requires greater attention to strict design guidelines. A vertical flow room would have air supplied through a perforated ceiling with HEPA filters and returned through a raised floor, producing nominally parallel airflow. Where grated or perforated floors are not suitable, such as in pharmaceutical applications, low-level sidewall returns are used. Clean spaces of different classes and airflow patterns can be combined in the same room by proper design and arrangement.
 6. In unidirectional arrangement, HEPA filter banks must be "pinhole" tight and checked for any pinhole leaks in the media, sealants, frame gaskets, and supporting frames.
-

Unidirectional Design Configuration

The unidirectional design is available typically in one of the three major configurations:

a. Clean Work Stations

- ✓ Involved the use of hoods with HEPA filters
- ✓ Large volume of air (90-100ft/min) at low velocity
- ✓ Filtering efficiency of 99.99% - filter of choice in all clean room designs.

- ✓ Used VLF (vertical laminar airflow) from ceiling to floor.
- ✓ Problem - difficult to maintain environment with people entering, moving and exiting the room

Note the acronym 'VLF' (vertical laminar flow) room is where air is typically introduced through the ceiling filters and returned through a raised access floor or at the base of the sidewalls.

b. Tunnel Design

- ✓ Tunnel design incorporates HEPA filters in ceilings instead of VLF hoods. The return is through raised floor or low wall.
- ✓ The arrangement is suitable for small portions in modular arrangement typically between 11 and 14 feet wide. Wider tunnels experience too much or turbulent flow.
- ✓ Only the localized area is provided with desired class level cleanliness rather than the whole area.
- ✓ The advantage of a tunnel is reduced HEPA filter coverage and ease of expanding additional tunnel modules into unaffiliated areas.
- ✓ The disadvantage is they restrict new equipment layouts as processes change, and products change.

c. Total Clean-Room (open bay design) Strategy

- ✓ Open bay designs typically use HEPA filters in the ceiling and returns in the floor. The design is suitable for large areas up to 50000 sq ft construction with interior walls placed wherever production processes dictate.
 - ✓ These rooms are more costly to build and maintain but do provide flexibility for change as new products are introduced and production equipment or processes are improved.
-

Unidirectional Flow System Designs

- 1) Single Pass System: Filtered air enters the room, exits through the louvers and is not re-circulated. The system is ideal for 100% makeup air or when ambient temperatures are favorable and acceptable.
- 2) Re-circulated System: Filtered air enters the room, exits through plenum walls and is re-circulated through a sealed plenum using motorized fan modules with HEPA filters. This is the most popular design.
- 3) Ducted Plenum System: Filtered air enters the room, exits through plenum walls and is re-circulated through air ducts directly to the HEPA filters.

(Refer to the figures under part IV)

3 ROOM PRESSURIZATION

A clean room facility may consist of multiple rooms with different requirements for cleanliness. Rooms in a clean facility should be maintained at static pressures higher than atmospheric to prevent infiltration by wind. Positive differential pressures should be maintained between the rooms to ensure airflows from the cleanest space to the least clean space. The only exception to using a positive differential pressure is when dealing with specific hazardous materials where the statutory health & safety agencies require the room to be at a negative pressure.

Ventilation Air

Ventilation air volumes are dictated by the quantity of air required to maintain indoor air quality, makeup for exhaust and for building pressurization. This provides assurance that carbon dioxide and oxygen remain in balance and that formaldehyde and other vapors given off by building

materials, paints / furniture etc are diluted, and that air changes occur with sufficient frequency to minimize the chance for high concentration of airborne pollutants within the building.

Pressurizing Limits

Positive pressure must be maintained to ensure airflows from the cleanest space to the less clean space. The idea is to inhibit the infiltration of unfiltered air. The cleanest room is kept at the highest pressure, with pressure levels decreasing as cleanliness levels decrease. A differential pressure of 0.03 to 0.05 inches water gage (wg) is recommended between spaces.

Static or active pressure control methods are used depending on the tolerances. Typical tolerance is ± 0.01 inches wg. Some semiconductor clean rooms require a precision of ± 0.0025 inches wg. In high precision rooms the control system must be responsive enough to maintain the differential pressure when doors are opened.

Makeup Air and Building Pressurization

Typically many of the critical clean zones have their own dedicated air conditioning systems. While this is good design strategy, many of the installations rely purely on re-circulation system without paying much attention to pressurization. Without pressurization, gaseous contaminants can seep into these sensitive rooms through cracks in wall and ceiling joints, cable and utility penetrations, and spaces above drop ceilings and below raised floors.

Positive pressurization is the basis of assuring that uncontrolled and untreated air does not infiltrate the protected area. The ambient air used to provide the positive pressurization must be treated to ensure environment free of both the gases and particulates. The recommended minimum amount of positive pressurization gradient is 0.03" to 0.05" (~0.75 to 1.25mm) water column for clean room applications. This would normally equate to 3- 8% of gross room volume.

Optimizing Makeup Air Requirements

Careful attention needs to be paid 'not to' over-pressurize the area.

With pressurization, the requirement for make up air and the treatment costs due to cooling /dehumidifying and chemical filtration also increases. The cost of treating the make up air shall be very high, particularly for the extreme ambient environment conditions.

The amount of outside air required is a function of

- Equipment exhausts and exhaust through toilets/kitchen/pantry/battery rooms etc.
- Leakage through pass through, conveyor openings, strip curtains, air locks, door under cuts etc
- Duct leakage, wall and ceiling leakages
- Level of positive pressurization required

The HVAC design must optimize the use of make up air and shall minimize the uncontrolled air leakages while maintaining the controlled ventilation.

Impact on Energy Use

Over pressurization is waste of energy that not only entails high capital costs but also increases the operating costs. One-inch water gauge pressure is equivalent to wind velocity of 4005 feet per minute (~45 miles/hr).

The makeup air requirements depend on the level of positive pressure required in the room. High positive pressure requirement require high makeup air quantities. With higher pressurization the leakage velocity, leakage rates and the processing costs shall also increase.

Leakage through the fixed openings should be restricted as much as possible. The amount of expected leakage can be calculated from the following:

$$\text{Leakage in CFM} = \sqrt{\text{Room Pressure in wg}} \times 4005$$

Assuming 0.05" wg,

$$\begin{aligned} \text{Leakage} &= 0.223 \times 4005 \\ &= 895 \text{ feet per minute} \end{aligned}$$

With a total of 2 square feet opening size

$$\text{Leakage} = 2 \times 895 = 1800 \text{ CFM}$$

Higher positive pressure of say 0.1" wg (2.5 mm) shall mean higher velocity pressure of 1266 fpm (~6.4 m/s). The amount of leakage for 2 square feet opening shall be 2532 CFM an increase of 40%. Higher the velocity pressure higher shall be the ex-filtration or the leakages.

Assuming an ASHARE design condition of 95°F DB/72°F WB (~35°C DB/22° C WB) and room conditions of 72°F DB/60°F WB (~22°C DB/15.5°C WB, ~50% RH), the enthalpy difference is 9.5 BTU/lb (~22 kJ/Kg) of air.

For 1800 CFM leakage: this corresponds to heat load of

$$\begin{aligned} &= 1800 \times 9.5 \times 4.5 \\ &= 76950 \text{ BTU's/hr or } 6.4 \text{ TR} \end{aligned}$$

For 2532CFM leakage: this corresponds to heat load of

$$\begin{aligned} &= 2532 \times 9.5 \times 4.5 \\ &= 108234 \text{ BTU's/hr or } 9.0 \text{ TR} \end{aligned}$$

This is not only the extra capital cost but also the recurring energy costs of nearly 6 kWh @ 1kWh per TR (3.5 kW) of cooling load.

The room pressure should be limited to 0.03" to 0.05" (~0.75 to 1.25mm) as pressure above this is very inefficient (high energy and treatment costs on chemical filtration)

Air Tightness of Building Shell

Positive pressurization can be maintained only if the sealing integrity of the building is maintained. The building should be air tight for low air leakage performance. There are areas within the facility that require negative exhausts such as toilets, pantry, laboratory or battery room but these are controlled ventilation areas having fixed amount of exhaust. Uncontrolled leakage areas in the building are door undercuts; pass through, walls, ceilings and duct joints etc; that should be restricted as far as possible. Remember a slogan;

“Build tight -ventilate right”

The building shall be optimally pressurized to achieve low capital costs, overall energy conservation and treatment costs on filtration.

PART – III ARCHITECTURAL, ELECTRICAL & NOISE ISSUES

Most clean rooms are designed for year-round cooling. Temperature control is required to provide stable conditions for materials, instruments, and personnel comfort. Humidity control is necessary to prevent corrosion, condensation on work surfaces, eliminate static electricity, and provide personnel comfort.

In addition to high end HVAC systems designed for effective filtration, pressure, temperature, and humidity regulation, the other design considerations include the room finishes, electrical distribution, noise control etc.

The room preparation plays an equally important role in meeting these requirements. Some of the key areas driving the clean room acceptance include:

1) ARCHITECTURAL ISSUES

1) Room Construction

- Rooms should be constructed using smooth, monolithic, cleanable, chip resistant materials with a minimum of joints and seams, and no crevices or moldings.
- Sheet vinyl and plastic- or epoxy-coated products shall be used.
- All doors, panels, etc. should be flush mounted or use sloped tops.

2) Flooring

Various types of flooring are used in clean rooms, depending upon cleanliness levels.

- Contamination control flooring may have a tacky finish to trap dust and other debris from wheels and shoes.
- Access flooring consists of solid or perforated panels or raised pedestals. Air can flow through perforated panels and can be exhausted in a sub floor area.

- Vinyl flooring features sealed seams to prevent accumulation of contamination. This material is considered suitable for high quality manufacturing sites; Class 100,000 thru Class 10,000.
 - Sheet Vinyl is most common in clean rooms of higher control. Homogenous material, which is solid vinyl, is preferred. Basically this material is supplied in rolls and serves to reduce the joints, cracks and crevices.
 - Control of electrostatic discharge damage can be addressed by the use of static dissipative or conductive materials such as chemical resistant rubber floors free of PVC, asbestos and halogen.
 - In general the number of joints, cracks and crevices should be reduced. Appropriate floor coatings could be applied to fill the joints/cracks/crevices. It is critical to avoid selecting a poured floor or coating that will deteriorate with use and subsequently contribute to the contamination – particle control.
-

3) Raised Access Floors

- Raised access floors are most suitable for applications in Class 100 and Class 10 facilities. Primary benefit is achievement of unidirectional flow of filtered air entering the clean zone. These systems are available in steel, aluminum and composite materials. The selection of the most appropriate material for your application should be discussed with the supplier. The choice of this approach for clean room flooring will be critical to the envelope and airflow system design
-

4) Ceiling Grid Systems

- Frameworks of parallel and perpendicular bars used to house filter and light fixtures in clean room ceilings.

- While some companies are maintaining a cautious approach and continuing to use the gel seal grid systems with 100% filtration coverage there has been a surge in the use of heavy duty gasket grid systems using a mixed flow design.
 - The traditional gel grid approach, which is usually associated with a pressurized plenum system or fan filter modules minimizes design change and is therefore a relatively low risk solution. The cost however is prohibitive due to the extensive air delivery system (full coverage filters, AHU's, chilled water, etc.).
 - The gasket grid approach to air flow utilizes less filter coverage (25-30%) with a concentration of filtration in some of the more critical areas. By introducing turbulence inducing devices down stream of the filter media you can improve the classification by mixing the air to create a "Turbulent Flow".
 - The ceiling should be pinhole airtight seal around the filters. Sealants are used to seal HEPA filters into ceiling grids. Plastic, silicone, and gel sealant are commonly used.
-

5) Vacuum Systems (House Keeping)

- A comprehensive clean room design shall include a vacuum system for routine house keeping. Sealed convenience receptacles for hose attachments can be placed on the raised floor walls to achieve full accessibility and coverage. PVC piping is used to direct particulate to the vacuum collection system. Canister, motor and filter can be located in a less sensitive area outside the clean rooms to prevent contamination.
-

6) Procedural Considerations (Air Showers, Gowning etc.)

It is important to adapt a proper procedure for personnel entering and exiting from the clean room.

- In absolute cleanliness requirements the personnel are required to wear a special purpose clothing (gown) to cover them.
 - Air showers are provided at the entry points that remove particulate contamination from clean room garments as personnel pass through. The chambers may include HEPA filters, interlocking doors, a re-circulating air system, and air nozzles in various patterns through which filtered air is blown onto the personnel in the shower. The air is moved over the worker, removing particulate contamination from the worker's garments.
-

7) Minimize Contamination from Clean-room Personnel

The additional measures needed are:

- Adhesive floor mats
 - Air pressure
 - Air showers/curtains/doors
 - Service bays
 - Double-door pass-through
 - Static control
 - Shoe and glove cleaners
 - Appropriate gowning (type of clothing, proper changing rooms)
 - Validated sanitation
 - Adequate transfer procedures for materials and personnel
-

2

MECHANICAL CONSIDERATIONS

1) Other Important HVAC considerations

- Humidity Control: Clean room service is intended for critical applications and therefore humidity control is critical and takes precedence over temperature control. The clean rooms HVAC design for latent//s load should consider the high operational ambient wet bulb data, not mean coincident dry-bulb/wet-bulb data as in conventional HVAC designs.

The reliability and availability of the HVAC system is critical to the success of the clean room manufacturing application. Typical design criteria is

- Temperature: 66 to 76°F
 - RH: 50 to 60%
 - Fresh Air: 20% to 100% fresh air.
- Redundancy: Some clean rooms operate around the clock every day. The cost of shutting down the critical manufacturing processes can be significant in these applications. Here, the cost of appropriate levels of redundancy could be paid off many times over.
 - Equipment: Equally strict measures fall upon the air handling equipment, drip pan, and ductwork systems. For clean room projects all air distribution system must be constructed and finished to the highest of standards and shall be specifically designed to minimize the possibility of dirt and bacteria build-up. The equipment must ensure that on-going maintenance is made as simple as possible to achieve continued cleanliness.
-

2) Noise Criteria

Noise is one of the major issues in clean room and the designs usually require high degree attenuation and use of acoustic silencers.

Clean rooms design due to large requirements of airflow is inherently noisy and requires a close attention to noise control. Clean room noise can be attributed to three primary sources:

- Fan noise
- Airflow turbulence
- Process equipment

The first two sources may be addressed by the noise-control engineer during the design of the facility. The manufacturers of that equipment must handle reduction of noise from process equipment.

A noise can be more annoying if it has a "hissy" high frequency spectrum, or a "rumbly" low frequency spectrum. In the production areas of an "average" facility, the noise at frequencies of 500 Hz and higher is mainly attributable to process equipment. At lower frequencies, it is due to the HVAC air-handling systems.

Airflow noise is due to the turbulence that is typically generated by the introduction of discontinuities in the airstreams (such as elbows or transitions), which is more prominent at high velocities.

Other than the equipment and the airflow noise the material characteristics of cleanroom provide a relatively "hard" acoustical environment. The bare block walls, raised access floor over a concrete structural floor, epoxy coated composite finishes and corrugated metal ceiling create highly reverberant conditions, which adds to the overall noise level.

The concern for shedding of particles generally prohibits the use of many conventional sound-absorbing treatments in the clean room or in the ducting of the air-handling systems.

[Points to note for Attenuation](#)

Following attenuation guidelines must be noted and applied:

- Where possible, use convex surfaces and deep texture (6" or more") on large surfaces to diffuse sound pleasantly.
- Avoid concave surfaces because the radial shape concentrates the noise into "Hot spots" which are objectionable.
- If surfaces are 70' away, more distinct echoes may be heard. Avoid having direct sound and reflected sound following paths more than 50' different in length. Large

parallel surfaces as little as 20' can produce rapid repeated reflections known as flutter

- Care should also be taken to specify low decibel refrigeration and air handling equipment to the supplier. Adequate measures as recommended by the vendor shall be taken while installation and normally, vibration displacement levels should not be dampened below 20 micro-inches in the 1 to 50 Hz ranges.
 - Include acoustic duct silencers in the design
 - Group noisy equipment together in the same area
 - Select equipment with low decibel level at rated capacity
 - Consider enclosing the noisy equipment in acoustic enclosures
 - Consider the travel of the sound and the acoustical properties of the area
 - Locate your work place away from the noisy areas/mechanical room
 - Choose HVAC mechanical room area that is isolated and protected
 - Liberally size the duct at low velocity. Route main ducts away from the work place
 - Place closets or storerooms etc. on the walls closest to the noise source
 - It is usually less expensive to avoid noise problems than to correct them.
 - Seal all holes and openings in walls
-

3 ELECTRICAL CONSIDERATIONS

1) General

- Individual breakers should be designed to handle 80% of their capacity
- Duplex Outlets per 20-amp breaker (depending on equipment amps)
- 10 Lights per 20-amp breaker

- 5 HEPA Fan modules per 20-amp breaker
 - All motors, HVAC and major equipment should be on isolated breakers
 - Breaker panel shall be surface mounted and sized to accommodate all of the clean room equipments.
 - Light fixtures shall be sealed Clean Room Type, available in (a) Flush lay-in troffer, (b) drop down lay-in troffer, or (c) Teardrop design.
 - Outlets shall be duplex type three wires, grounded, white color 20 amp / 120V. Other options include isolated circuits and other amperage and voltage receptacles as required.
 - Switches are quiet-type and designed to control the light fixtures as required.
-

2) Power Requirements

- Due to the potentially high electrical requirements of clean rooms all amperage drawn by electrical items must be totaled and a determination made as to the capacity and availability of existing power. Transformers and additional power feeds may be required.
-

3) Typical Amperage Criteria

- Fluorescent Light Fixtures 2 Amps each
- HEPA Fan Modules 4 Amps each
- Duplex Outlets 3 amps each (depends on equipment amp draw)
- Air conditioning Chillers, Air Handling units, dehumidifiers, humidifiers, motorized dampers & other equipment etc. will vary depending on size and voltage.

Note: Equipment of equal size, tonnage or horsepower will have a lower amperage draw if higher voltage models are used.

4 CERTIFICATION REQUIRMENTS

The clean room certification and acceptance procedures shall be in accordance with NEBB Procedural Standards for Certified Testing of Clean rooms.

Qualified clean room performance testing (CPT) firm shall undertake the following tests for certification.

- ✓ Airflow Velocity and Uniformity Tests
 - ✓ HEPA Filter Installation Leak Tests
 - ✓ Room Particle Count Tests
 - ✓ Enclosure Pressurization Tests
 - ✓ Temperature and Humidity Uniformity Tests
 - ✓ Sound and Vibration Tests
 - ✓ Light Level and Uniformity Tests
 - ✓ Recovery Tests
 - ✓ Conductivity Tests
 - ✓ Particle Fallout Count Tests
 - ✓ Electrostatic Tests
-

System Design Example

Consider a manufacturing facility, which is divided into 3 separate zones according to application and cleanliness requirements.

- The manufacturing & assembly line requires Class 10 level, 20' x 40' x 8' high
- The mechanical cleaning area demands class 1000 level, 40' x 50' x 8' high
- The mechanical transfer area is identified as Class 10000, 40' x 50' x 8' high

Suggest the typical clean room HVAC requirements for each area. Assume any relevant data for the application.

Conceptual Scheme

Each clean room shall have a high-efficiency particulate air (HEPA) filtration system, air circulation, airlocks and pressure control.

Parameters	Class 10	Class 1000	Class 10000
Room Dimensions	20' x 40' x 8' high	40' x 50' x 8' high	40' x 50' x 8' high
Room Volume	6400 cuft	16000 cuft	16000 cuft
Filter Coverage	100%	30%	15%
Filter Population	800 sqft	600 sqft	300 sqft
Air Velocity	90 FPM	40 FPM	15 FPM
Air Circulation	72000CFM	24000 CFM	4500 CFM
Air Changes	675 air changes/hr	90 air changes/hr	16.8 air changes/hr

The Class 10 clean room shall have 100% HEPA coverage at the ceiling, re-circulating fans, raised floor and return air chase, pressurization, vibration and noise control.

The Class 1000 clean room will have a raised floor or low wall return, 30% + HEPA coverage at the ceiling/duct, pressurization, vibration and noise control.

The Class 10,000 clean room will have 15%+ HEPA coverage in a duct, sidewall return, pressurization, vibration and noise control.

Other mechanical and room finish requirements could be verified from checklists below:

Mechanical Requirements

CLEAN ROOM DESIGN CRITERIA (Mechanical Practices)					
Criteria	Class Limits				
	10	100	1000	10000	100000
Air Changes Per hr	600	300-480	150-250	60-120	10- 40
HEPA Filter Coverage %	100	70-100%	30-60%	10 - 30%	5-10%
CFM per Sq. Ft.	90	65 - 36	32 -18	16- 9	8 - 5
Typical Filter Efficiency	99.9997	99.997	99.997	99.997	99.97
Typical Filter Velocity	60-110 FPM	50-90 FPM	40-90 FPM	25-40 FPM	10-30 FPM
Air Flow Type	Unidirectional	Unidirectional	Mixed	Mixed	Mixed
Typical return air System	Raised Floor	Low Wall	Low Wall	Low Wall or Ceiling	Low Wall or Ceiling
Generic Cost Estimate (\$ per sq ft)	600-750	450-650	160-260	60-70	40-50

*Clean room costs rise, as the clean room class gets lower. This rise in cost is associated with increased filtration and air handling equipment and the tighter the temperature and humidity controls the higher the cost. On average the larger the room the lower the square foot cost within that clean room class.

CLEAN ROOM DESIGN CRITERIA (Finish Elements)					
Criteria	Class Limits				
	10	100	1000	10000	100000
Minimum Wall Surface	Steel Porcelain or Epoxy Paint	High Pressure Laminate or Steel	Vinyl	Vinyl	Vinyl
Optional Surface		Steel, Porcelain or Epoxy Paint	Smooth Steel	Embossed Steel	Embossed Steel
Paints	Epoxy	Epoxy, Powder, Enamel	Epoxy, Powder, Enamel	Latex, Enamel	Latex, Enamel
Window Type	Beveled Sill	Beveled Sill	Beveled Sill	Beveled Sill	Beveled Sill
Typical Ceiling Type	Mod / 2" T - Bar Gel Seal	Mod/2"T- bar/ Gskt.	1" Tbar/ Gskt.	1" Tbar/ Gskt.	1" Tbar/ Gskt.
Grid Design and Support	Gel Seal w/ unistrut all thread rod turnbuckles	Gasketed All thread w/ unistrut all thread rod turnbuckles	Gasketed 12 ga wire to grid. 10 ga wire to filter turnbuckles at filter	Gasketed 12 ga wire to grid. 10 ga wire to filter turnbuckles at filter	Gasketed 12 ga wire to grid. 10 ga wire to filter turnbuckles at filter
Flooring (depends on floor use)	Mipolam or Equal	Mipolam or Equal	Mipolam or Equal	Sheet Vinyl	Sheet Vinyl
Lights	Incorporated in HEPA filters	Incorporated in HEPA filters	Special Sealed Fixture	Special Sealed Fixture	Special Sealed Fixture

PART – IV TYPICAL ARRANGEMENT & ENERGY CONSERVATION

1 Clean room Arrangement

The common HVAC clean room design has the filtered air distributed via the ceiling void area into the controlled room area and is taken out via the floor void or low wall return. The main reason is to keep the contaminants directed downwards as a result of unidirectional flow.

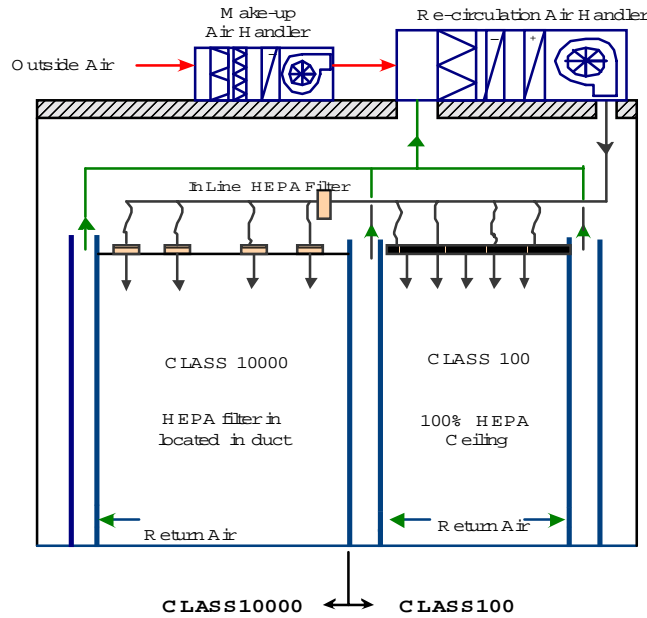

Figure #1

In the scheme above, the class 100 room arrangements is shown with 100% HEPA filter coverage. In practice, the make-up air handler (MAH) is a fresh air unit that provides the room pressurization. The MAH is designed for latent and sensible load of outside air. This unit feeds to single or multiple re-circulation air handlers that are designed for the internal sensible heat load from process machinery and the personnel.

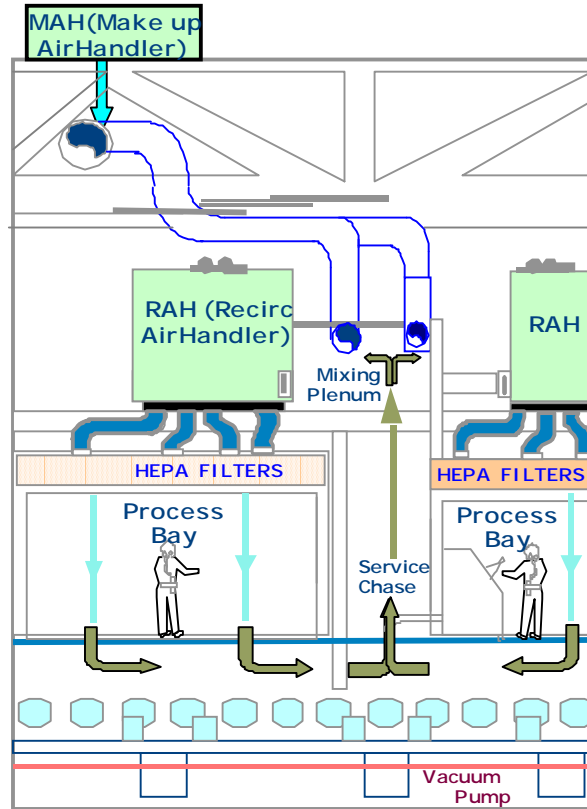

Figure #2 (Clean room Arrangements with Raised Floor Return)

The figure # 2 above shows Class 10, Unidirectional Air Flow Arrangement. The figure depicts raised floor return arrangement unlike the low wall return arrangement shown in figure# 1.

Why Raised Floor or low wall returns?

Typically in a clean room, outlets supplying air to sensitive ultra clean areas and highly contaminated areas should be located on the ceiling, with perimeter or several exhaust inlets near the floor. This arrangement provides a downward movement of clean air through the working zones to the contaminated floor area for exhaust.

The clean room design follows the 180° unidirectional airflow approach. By 180°, it implies that either

- 100% fresh air is thrown into the space at ceiling end and is exhausted at the opposite lower end
- Or a separate return service chase is provided so that the re-circulated air is independent of the supply air and do not result in turbulence to the unidirectional flow (as shown in both the figures above)

This design approach allows the contamination generated by the process or surroundings to drift in direction of supply air that leads to the floor void or the low wall return. The particles are finally captured by the vacuum pump in the floor void or by the HEPA filters in the ceiling. The return is taken via an independent service chase.

Clean room designed for an access-floor air-conditioning system functions as an oversized plenum to accommodate the frequent air changes necessary in clean zones and open clean rooms.

In some designs the arrangement is reversed. Floor void is used as a supply air channel where the supply air is projected upwards and is drawn into a ceiling void. The airflow projecting upwards with a force result in particle agitation and migration, which is similar, like a ping pong balls used in bingo games.

This arrangement is preferred in applications where the localized hardware or equipment has high heat dissipation. The conventional supply airflow from ceiling may not be directional enough to cool the equipment that results in hot spots.

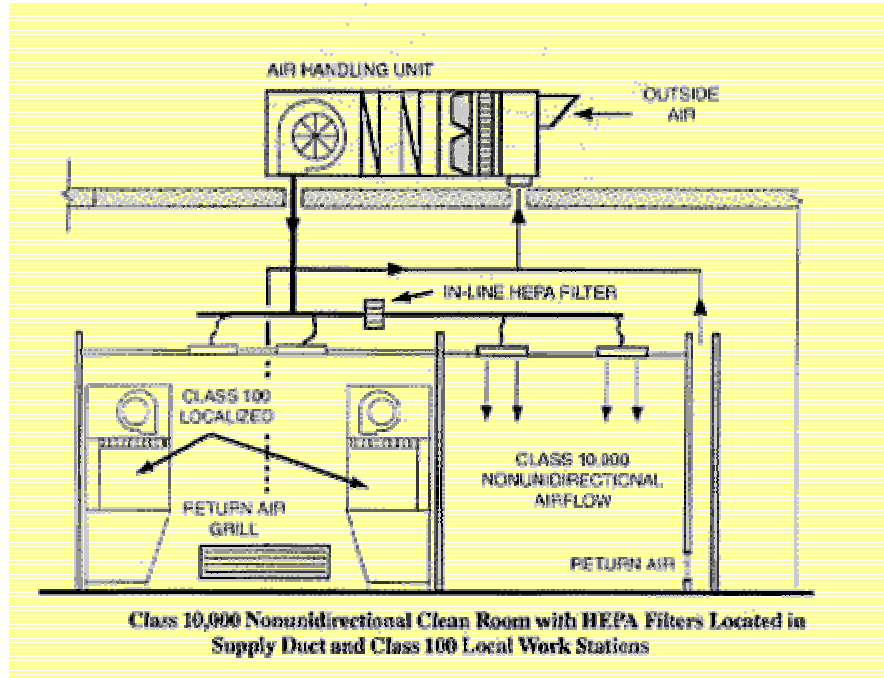

Figure # 3 (Clean room Arrangements with Localized Work Stations)

2 Energy Conservation

Clean rooms present large opportunities for saving energy majority of which can result from mainstream HVAC system design concepts. Not unexpectedly, airflow design emerges as the key element in any strategy to capture savings in clean rooms.

In spite of the fact that the clean room operations are highly energy intensive, still the energy efficient HVAC designs/technologies have largely been ignored. The reasons could be attributed to:

- First, new manufacturing facilities are brought into production on an extremely fast track due to short product cycles and intensely competitive market pressures. The

compressed schedule cuts into time allocated for design of facility and process engineering, with the result that energy efficiency improvements get little attention.

- Second, high value for the product puts a premium on reliability of overall production facility in terms of minimizing production line downtime and defects due to contamination. This promotes extreme conservatism in clean room design and operation.

The most significant factor affecting both the initial and operating costs of clean rooms is the airflow. As industries and markets grow more competitive- and as the unarguable edict of energy conservation becomes widely accepted in all industries- it is necessary to re-evaluate existing methods of airflow design, and as part of that review, to consider new ways of thinking about air handling and the efficacy of newer methods.

- 1) The first step towards energy efficient design is right classification of the building. For instance it is not prudent to design the whole building to Class 100 when significant proportion of the building could be classified as Class 10000. Or in other words a less critical area must not be provided with high-class classification just for conservatism. The process specialist should identify and segregate the critical and non-critical areas judiciously based on the requirements and manufacturer's recommendations.
- 2) Capture savings by creating mini clean room environments in a sense that instead of providing entire area with class 100, if localized workstations of class 100 shall suffice. Use any available industry benchmarks that may exist for energy efficiency
- 3) Challenge the room volume. Seek opportunities to evaluate whether conditions permit to minimize clean room volume: Doing this reduces re-circulation airflow requirements and the associated energy usage.
- 4) In planning a clean room facility, zones of cleaner air can be established by concentrating HEPA filters in a particular ceiling area. Rather than providing a full filtered ceiling, create class 100 within class 10000 areas. This is more efficient than the typical class 10000 rooms with class 100 benches and workstations.

- 5) Locating portions of process equipment in chase ways, with clean access on the room side, can decrease floor space requirements as well as lessening heat gain and exhaust needs.
- 6) Carefully evaluate the air distribution system. The major energy savings can accrue from the air distribution. The fan energy is proportional to the volume of air and the total static pressure used. Any reduction in the air velocity and filter coverage shall lead to the reduction in Fan HP. Some of the ways to optimize the static pressure are
 - ✓ Minimize obstructions to air flow, run straight duct lengths and avoid arbitrary zigzags
 - ✓ Select cooling coils, sound attenuators and filters with low air pressure drop
 - ✓ Keep low face velocity
 - ✓ Select high efficiency filters. Higher-performance air filters clean supply air more efficiently, resulting in a reduction of energy consumption.
 - ✓ *Avoid excessive safety margins*
As a rule of thumb every 1" wg static pressure shall result in 1.1° F rise in temperature of air.
- 7) The greatest single HVAC load in a typical clean room is the heat load from outside air. A large amount of outside air is needed for makeup exhaust losses & leakages and also for clean zone pressurization requirements. Build tight and ventilate right should be the design principle. (refer part III, section 3 for details)
- 8) Specifying high efficiency components, including high efficiency motors and fans, chillers and other equipment.
- 9) Variable-speed drives: When used in air re-circulation, make-up, and exhaust fan motors, these drives use 15-30% less energy than constant-speed drives.
- 10) Consider separate make up and re-circulation AHU units. Provide re-circulation AHUs with sensible conditioning apparatus and make-up AHUs with sensible and dehumidifying coils

- 11) Consider lowering unidirectional vertical laminar airflow to 65- 70 fpm air velocity
- 12) Challenge exhaust air requirements and limit it no greater than 4 cfm/ft². Make-up air 125% of exhaust air requirements for pressurization (i.e. 5 cfm/ft²)
- 13) Consider silencers for dampening fan noise and select it for low pressure drop
- 14) Screw and centrifugal compressors enhance chiller reliability. Modern centrifugal chillers consume as little as 0.60 kW per ton of refrigeration and machines equipped with the variable-speed technology yield greater energy savings for a faster payback.
- 15) Consider the chillers with high energy efficiency ratio. Centrifugal chillers offer efficiency as high as 0.60 kW/ton
- 16) Challenge design if the following exceeds the limits:
 - Static pressure of 4" wg on makeup air units
 - Static pressure of 2" wg on re-circulation air units
- 17) Challenge design if the following is lower than:
 - Fan efficiency 85%
 - Fan motor efficiency 94%
- 18) Evaluate low temperature air cooling with low chilled water temperatures of 40- 42° F. Low temperature air distribution offers reduction in air volumes and lowers the requirement of ducting, insulation, fan sizes etc.
- 19) Evaluate chillers with large temperature ranges to say 16°F. High temperature range shall result in slightly over sizing the evaporator but shall lead to reduction in chilled water flow rates, reduced pump and motor size, lower pipe sizes and insulation requirements.
- 20) Present processes require closer temperature and humidity tolerances sometimes as low as ± 0.5° F, ± 2% RH. In majority of cases the cooling equipment is also used to dehumidify. The humidity control is achieved by chilling mixed air down below

dewpoint in deep DX or chilled water coil (40deg F entering water temperature) and adding reheat. When critical control is required the humidity control takes precedence over the temperature control implying that the cooling coil shall operate at full capacity even if the temperature drops below the set point. Temperature is again raised to the set point by employing reheat. This approach provides a reliable control approach but at great energy cost as the energy is first used to sub cool and than to reheat to the set point. If the make up air heat gain is high, the reheat cost will be significant. An energy efficient solution to this shall be to employ two cooling coils.

- The first shall be provided in the make up AHU for taking care of sensible and dehumidification load of outside air.
- The second coil shall be designed for the sensible heat load of the process equipment.

The majority of the latent (moisture) load is because of the large quantities of outside make up air, which is fairly constant. The indoor latent load is insignificant and is largely the sensible load from the process machinery.

The scheme shall allow the second coil in the re-circulation unit to operate in partial capacity as soon as the temperature set point is achieved. The reliance on reheat shall be considerable reduced.

- 21) Carefully evaluate the fan selection among the forward curved, backward curved and in-line vane axial fan. Blower selection is often a function of scale, both in volume and required static pressure.
- 22) The present trend is towards the use of packaged fan and filter units. This is done for reduced noise levels, redundancy and quick installation. But this arrangement is prone to generally lower efficiencies. It is always advantageous to use a large belt driven fan with high efficiency motor located out of air stream.

- 23) Fan motor location must be considered in terms of energy efficiency. Many typical modular systems utilize a large number of fractional horsepower direct drive motors at the terminal ends, which operate in the airstreams. These are usually single-phase motors, which have high power factor but low efficiency. Because of their location, they impart heat to the airstreams. Location of motors outside the airstreams not only limits heat gain but allows greater service access as well.
- 24) Proper duct seals in clean room mechanical systems as another critical component. Discharge ducting operates in the medium-high pressure range. Discharge losses will increase outside makeup, with leakage at substantially higher velocity than room leakage. Thorough perimeter ceiling should be specified in clean room design, including gaskets and clips on ceiling tiles, joint gaskets on modular walls/pressure plenums, and seals at floors and structural connections.
-

PART – V CASE EXAMPLES (BIOCLEAN & SEMICONDUCTOR ROOMS)

The requirements for clean rooms depend on the classification and use.

Factors that contribute to quality products:

- Starting materials and packaging materials
- Validated processes
- Personnel
- Procedures
- Equipment
- Design and quality of premises
- Manufacturing environment
- Inadequacies in the above factors will lead to sub-standard products.

The manufacturing environment is critical for product quality. The environment optimization include

- Light
- Temperature
- Humidity
- Air movement
- Microbial contamination
- Particulate contamination

Uncontrolled environment can lead to product degradation /*Loss of product and profit*

The bio-clean areas include the pharmaceutical facilities, animal laboratories, radioisotopes lab, research laboratories, surgical theatres etc while the industrial clean room could be the semiconductor manufacturing, electronic assembly, aerospace assembly etc. etc. Clean rooms in the industrial application such as microelectronic semiconductor business are somewhat different than those in the bio-clean applications.

The common element:

The common design goal with both the semiconductor facility and bio-clean facilities require a high level of filtration and certainty that the specific spaces are fully disconnected from the outside environment: the ideal is zero air exchange.

The clean room environment in both types of facilities is an attempt to maximize production rates and yields for environmentally sensitive materials and products. Most clean rooms in the pharmaceutical or semiconductor industry are characterized by high requirements in terms of the availability of the entire system. Therefore, the system must have redundancy in each critical element.

The distinctions are:

- Bio-clean facility is an area or suite of rooms where sterile (absence of living organisms) conditions are required. The rooms have a defined environmental control that are constructed, maintained and used in a way to minimize the introduction, generation and retention of particulate and in particular germs & microbial contamination.
- With bio-clean facilities the primary concern is to control the types of contamination rather than the quantity of non-infectious particles present. For pharmaceutical plants the cross-contamination of various products is the major issue, for instance one drug chemical should be 100% separated from the other. The industrial clean rooms such as semiconductor room are designed to target particulates sizes down to 0.1 micron to safeguard the product.
- Bio-clean facility must be free from microorganisms and endo-toxins (degraded microorganisms) owing to health and safety reasons.
- The bio-clean facilities depending on the severity of application require the sterilization, germicide equipment and alcohol based spray disinfections apparatus. Sterilization processes and waste disposal pose significant concerns with regards to air borne molecular (AMC) control. There could be concerns of odor smells depending on the

sterilization procedures and sterility agents being used. Odor control applications may also require tight control in order to reduce odors below levels that would be considered objectionable by clean room personnel and/or to meet regulatory requirements.

- The bio-clean facilities do use substances, which may vaporize as toxic products. These irritants may warrant special attention considering that exposure to these materials can have long-term health effects to the operating personnel.
- The clean space in bio-clean facilities particularly where there is tendency for bacteria and/or pathogens to accumulate are often designed for negative pressures per the requirements of statutory regulations.
- The floor planning in bio-clean facilities is generally segregated in small rooms while the industrial areas have much bigger zones.
- The bio-clean facilities sometimes do require exhaust air treatment besides fresh air and re-circulation air treatment. Prevention of pollution to outside is also a major concern. Exhaust air systems generate a significant number of complaints from neighboring facilities due to nuisance odors from exhaust abatement equipment. Careful location of exhaust stacks, compliance with environmental regulations, and dispersion modeling are required for all production facilities.
- Room cross-contamination is a major concern. For instance one drug should not be tainted with other chemical during manufacturing, assembly or packaging. To prevent cross contamination, the clean room must have a higher pressure than the surrounding lower classified rooms.

Regulatory Guidelines

Designing HVAC systems for bio-clean-room projects, such as pharmaceutical units, laboratories hospitals, is a specialist skill which requires knowledge of specific regulations”

There are a number of regulatory requirements that must be met that differentiate these clean rooms from those used for other purposes. Few important regulatory agencies for pharmaceutical units are:

1. Guideline on Sterile Drug Products Produced by Aseptic Processing, FDA 1987 provides guidance on practices and procedures for the preparation of sterile drug products that constitute compliance with the GMPs (good manufacturing practices) under 21CFR, 210 and 211. This document provides specific recommendations for viable particulate levels, airflow rate and pressure differentials in aseptic processing areas for various clean room classifications. Definitions of critical and controlled areas are also addressed in this document. This document also addresses equipment, facilities, personnel and sanitation.
2. The facilities must follow the EU-GMP (cGMP) guidelines. GMP is the acronym for Current Good Manufacturing Practices. GMP is defined as a set of current, scientifically sound methods, practices or principles that are implemented and documented during product development and production to ensure consistent manufacture of safe, pure and potent products.
3. The two common regulatory agencies; EU-GMP and FDA categorize the pharmaceutical units as follows:
 - a) EU-GMP/ WHO requirements
 - Class A: For instance
 - Preparation of solutions for aseptic filling
 - Depyrogenisation of containers
 - Filling of aseptic process
 - Class B: Background for the sterile Class A zone
 - Class C: Clean areas for less critical activities for instance
 - Preparation of solution for terminal sterilization
 - Filling of terminal sterilization
 - Class D: Clean areas for less critical activities, for instance

- Washing of containers

b) US FDA requirements

- Critical area: Zone/part of room where filling of sterile products or other sterile processes take place.
 - Controlled area: Room / area where the product is formulated filled and sealed.
4. Federal Standard 209E and British Standard 5295 lay general guidelines for clean rooms.
 5. The new ISO 14644 standards shall probably be the future working document for designing all clean rooms, since the standard is industry-specific, describing standards for the hospital sector, food industry, pharmaceutical industry and electronics industry.

Bio-clean Rooms

Rooms that are germ free room or which have fewer microbes than general areas are referred to as bio-clean rooms. Normally, in order to create such environments, high-performance HEPA air filters are used. These air filters are capable of trapping 99.97 percent of 0.3-micron particles, and even bacteria are trapped in these air filters. The typical organisms of concern are:

Microbes	Size
Protozoa	Several microns to several dozen microns
Mold	Several microns
Bacteria	1 micron
Rickettsias	0.3 microns
Viruses	0.01 to 0.2 microns

Note that the ‘Rickettsias and Viruses’ are smaller than the size of particles that can be trapped in the HEPA filters. In reality these organisms are not floating in the air in single units (rickettsias live inside insects, and viruses attach to dust floating in the air). Therefore if insects and dust can be eliminated it is possible to ensure a biologically clean environment in the room. The cause of

contamination of bio-clean rooms is the equipment/materials and people brought into the room. An important precaution is while entering or carrying in equipment/materials to bio-clean rooms, people and equipment must pass through barrier equipment.



Aseptic Clean Rooms for Pharmaceutical and Bio-manufacturing

Aseptic is the absence of microorganisms capable of causing infection or contamination.

The objective of aseptic processing methods is to assemble previously sterilized product, containers and closures within specially designed and controlled environments intended to minimize the potential of microbiological or particulate contamination.

Levels of Protection

Based on the clean room class requirements, various 'Levels of Protection' have to be created, including:

- Correlation between process operations and clean room classes
- Type of operation permitted in each Level of Protection
- Definition of clean room class (parameters, building materials, room requirements, HVAC systems)
- Requirements for personnel and material in the different classes (clothing, training, type of materials, etc.)
- Requirements on entry conditions for personnel and material (change procedures)

Parameters influencing Levels of Protection

- Number of particles in the air
- Number of microorganisms in the air or on surfaces
- Number of air changes for each room

- Air velocity
- Airflow pattern
- Filters (type, position)
- Air pressure differentials between rooms
- Temperature, humidity

HVAC systems serving aseptic biotechnology, pharmaceutical, and life science clean rooms shall be designed to ensure the level of protection. The working environment must be sufficiently well controlled to minimize process defects, assure product quality, and to provide for worker safety and health.

The basic principle of pressurization for microbial contaminant control is to supply air to areas of least contamination (greatest cleanliness) and stage this air to areas of progressively greater contamination potential. The pharmaceutical operations are generally arranged in suites, with clearly defined operations in each space. The highest quality core room is generally placed at the center, which is separated to the lesser quality room by differential pressure using air locks. For example, an "aseptic core" (Class 100) filling area is located in the innermost room space in a building plan area. The highest room air pressure is maintained in this area. It is surrounded by areas of descending pressures. Or in other words these areas can tolerate increasing particle classes. A commonly used pressure level difference between room classes is 0.05 to 0.06 inches water gauge to inhibit particles from entering.

An alternate perspective on the design principle of pressurization control is to exhaust air from those areas, which have the greatest contamination potential, and allow air to be staged, or cascaded, from progressively cleaner areas, or the areas it is desired to protect. Systems, which combine negative pressurization in contaminated areas with positive pressurization in clean/protected areas, will have the greatest degree of protection and control. For instance in pharmaceutical areas where product containment issues (where dangerous bacteria or pathogens are involved), the suite must be at a lower pressure than the surrounding areas. In this

case the area must be forced exhausted and air lock must be maintained at least one pressure level difference higher than the adjacent areas.

The regulations mandate manufacturers to establish & maintain procedures to adequately control environmental conditions. Lighting, ventilation, temperature, humidity, air pressure, filtration, airborne contamination, and static electricity are among many conditions to be considered for control. National and international health authorities carry out periodical inspections to ensure that manufacturers comply with current regulations as laid out in EU-GMP and/or FDA. Few important features of inspection are listed below that must be well taken care during design.

- [Testing of the number of air changes](#) The purpose of the air change in a clean room is to ensure an optimum removal of any contamination from the operator or the product. Further the ventilation in a clean room should maintain an acceptable working climate.
- [Down flow test of UDF units](#) In a clean room having zones with a room classification of critical or class A, a UDF (Unidirectional airflow) cover is established, which means that the whole critical production area is supplied with HEPA filtered air. The aim is that the air is supplied as laminar as possible, and the “used” air should have a direction away from the production area. The laminar flow is established by the smoke flow test for a visual control of the airflow direction and is often video filmed for documentation.
- [Room pressure differences:](#) There is a concern with cross-contamination from one production/process area to another and the potential for “tainted” product or a problem with the integrity of packaging for drugs and medical devices. To prevent cross contamination, the clean room must have a higher pressure than the surrounding lower classified rooms. If the pressure direction between the clean room and a less clean room is wrong, “you may install as many HEPA filters you would like, and still not reach the desired room classification”.
- [Testing of HEPA filters \(leakage measurements\):](#) The “heart” of a clean room is the HEPA filter. To obtain the required room classification, it is very important that the air is optimally filtered. The condition of the filters is a very critical parameter in the clean room

and should, therefore, be periodically tested (typically every 6 months). The purpose with the test is to measure any leaks in the filter (or housing), and not, to document the filtration efficiency “this is the filter suppliers responsibility, as they must supply individual test certificate with each filter”

- **Airborne Molecular Contamination Control:** AMC is a type of non-particulate, or molecular contamination, which is not controlled with traditional HEPA air filtration. AMC can be in the form of gases, vapors or aerosols that is the result of outdoor air, manufacturing processes, fugitive emissions from process equipment, cross-contamination between manufacturing areas, chemical storage areas, accidental spills, and bio-effluents from clean room personnel. The AMC control is required to eliminate toxic, odor and irritants particles for operating personnel safety and health and must be carefully evaluated for each area.
- **Prevention of pollution:** Prevention of pollution to outside is also a major concern. By using ANSI standards, good engineering practice, and compliance testing procedures, the following design requirements are established:
 - Exhaust discharge point at least 10 ft above adjacent rooflines.
 - Minimum exhaust discharge velocity of 3,000 fpm.
 - Minimum outside air intake to exhaust point separation of 100 ft.
 - Outside air intake located upstream of exhaust point when considering local prevailing wind conditions.
- **Cross contamination**

According to WHO, the cross contamination is the contamination of a starting material, intermediate product or finished product with another starting material or product during manufacture. It has been proven that one of the major reasons for cross contamination is the air handling units and extraction systems. Inadequate procedure for personnel and equipment and insufficiently clean equipment is another key reason. Cross contamination could be minimized by

- Personnel procedures
- Adequate premises
- Use of closed production systems
- Adequate and validated cleaning procedures
- Appropriate levels of protection of product
- Correct air pressure cascade

The air handling system must take into account the contamination and cross contamination issues; establish product sensitivity to environment and to the therapeutic risk.

- Auxiliary equipment and facilities: The bio-clean rooms must include the auxiliary equipments such as changing rooms, air showers, hand-washing equipment, emergency eyewash & showers, jet towels, alcohol spray disinfections apparatus, Autoclave, EO gas sterilization apparatus, Germicide, pass box etc. etc.... The additional measures include; appropriate gowning, change rooms, validated sanitation, compressed air blows etc.

2

Clean Rooms –Non-aseptic Pharma Manufacturing/Health Care

The clean spaces for non-aseptic product manufacturing follows the same general approach as aseptic pharmaceutical manufacturing, but with fewer critical parameters and components to be qualified. In making powdered materials, humidity level and control may be more rigorous; in these cases the HEPA filters perform more of a dust catching role than bacterial control. Here filter efficiency is more important than pinhole testing.

Isolation Rooms in Health Care

The basic air conditioning requirements for health care facilities are

- (1) The need to restrict air movement in and between the various departments;

- (2) The specific requirements for ventilation and filtration to dilute and remove contamination in the form of odor, airborne microorganisms and viruses, and hazardous chemical and radioactive substance;
- (3) The different temperature and humidity requirements for various areas; and
- (4) The design sophistication needed to permit accurate control of environmental conditions."

Isolation rooms and isolation anterooms with appropriate ventilation-pressure relationships are the primary means used to prevent the spread of airborne viruses in the hospital environment."

The isolation rooms can be classified in three basic categories:

- Negative Pressure Isolation Rooms
 - Positive Pressure Isolation Rooms
 - Multi-level Biohazard Laboratories
- 1) Negative Pressure Isolation Rooms maintain a flow of air into the room, thus keeping contaminants and pathogens from reaching surrounding areas. Because of potential litigation concern, the exhaust air is also normally filtered through HEPA filters to ensure contamination free release to environment. Generally the infectious areas are maintained negative pressure with respect to adjacent spaces. A simple example of negative pressure isolation room is in health industry for Tuberculosis (TB) Rooms. 6 to 12 air changes are recommended from TB rooms. Supply air to the room, is also filtered. Ultraviolet Germicidal Irradiation (UVGI), commonly known as UV light, may be used to augment HEPA filters, but cannot be used in place of HEPA filters, as their effectiveness on airstreams is limited.
 - 2) Positive Pressure Isolation Rooms maintain a flow of air out of the room, thus protecting the patient from possible contaminants and pathogens, which might otherwise enter. The most common application today is HIV Rooms and rooms for patients with other types of immunodeficiency. For such patients it is critically important to prevent the ingress of any pathogens, including even common fungi and bacteria, which may be harmless to healthy

people. Design criteria for HIV Rooms are similar to those for TB Rooms. UVGI systems are sometimes used in conjunction with HEPA filters.

What if the AIDS patient is also suffering from TB? This presents a unique design problem.

One solution is to house the positive pressure (HIV) room within a negative pressure (TB) room, or vice-versa, which would be similar to a pair of nested biohazard levels.

- 3) [Biohazard laboratories](#) are merely isolation rooms with strict requirements defining their degree of air tightness, pressurization and associated equipment. There are four biohazard levels, in level 1 defines a simple isolated area, and in which level 4 defines a near perfectly airtight zone requiring breathing apparatus and airtight anterooms or staging areas. Specific information on laboratory design is widely available from various sources, including ANSI and ASHRAE.

[For further reading refer to](#) American Institute of Architects 1996-97 Guidelines for Design and Construction of Hospital and Health Care Facilities,

Chapter 7; Health care facilities, ASHRAE handbook, HVAC applications, 1995

Guidelines published by Centers for Disease Control and Prevention (CDC)

3 Clean Rooms - Semiconductor Manufacturing

The production of microelectronic semiconductor products requires a facility that is environmentally controlled and virtually free from contaminants. Most microelectronic manufacturing requires Clean Room Class 100 or cleaner. A deposited particle having a diameter of 10% of the circuit is likely to result in a circuit failure. With circuit line widths of 0.25 microns, particles of 0.025 microns are a concern. Air ionization technology is sometimes used in addition to HEPA filter particle control.

[Common design practices in existing facilities:](#)

- 1) The facility is segregated to various class levels according to requisite needs. For example, the uncrating of incoming items may be Class 100,000, the next stage of setup and inspection is Class 10,000 area and the final stage before entering the main area is Class 1000.
- 2) Semiconductor clean rooms generally use vertical unidirectional airflow with raised floor return. The particles are swept from personnel and equipment with contaminated air leaving at floor level. This results in clean air for all space above the work surface.
- 3) The ceiling area is 85 to 95% covered with HEPA filters set in a T-bar grid with gasketed or caulked seals for Class 100 rooms.
- 4) Class 1 and 10 rooms use 100% filter coverage with ceiling grid using special gels to seal the filters into a channel shaped grid.
- 5) The space pressurization is key to resistance to infiltration of external sources of contaminants. Semiconductor clean spaces usually have plenum systems that are designed to ensure even pressurization to keep uniform airflow through each filter. Ducted filters where employed typically have higher static pressure losses from the ducts and balancing dampers, and have a higher maintenance cost due to the balancing needed.
- 6) Individual fan-powered filter modules are often provided which use fractional horsepower motors and usually forward curved fans to flow air through one filter assembly. This allows airflow to be varied and takes less space for mechanical components. The disadvantages are the large number of fans involved, low operating efficiency, potentially higher noises, and higher operating and maintenance costs.
- 7) Air is normally returned through perforated raised floor panels or floor grates. There may be vibration problems if the panels are not very rigid. Insufficient raised floor height may cause turbulence, raising particles up, and increase system static pressure. Basement return is often used as it provides a more uniform return and can more effectively handle chemical spills.

- 8) Adequate pre-filtration is typically used to economically increase HEPA filter life. The pre-filters shall not be located in a way that they obstruct operations and have to be accessed for cleaning and replacement through the clean room.
- 9) Process exhaust systems vary from 1CFM per sq ft for photolithographic areas to 10 CFM per sq ft for etching, diffusion and implant process areas. In the absence of specific design layouts, a value of 5CFM per sq ft is often used. Exhausts are segregated into corrosive fumes (using plastic or reinforced fiber glass materials), flammable solvent vapors, and heat exhausts (using metal components).
- 10) Precise temperature and humidity control is required in the microelectronic facility. In semiconductor industry, tolerances of $\pm 1^{\circ}\text{F}$ are common, and some processes even require ± 0.1 to 0.5°F . In Class 100 areas or better, personnel wear full coverage gowns that require room ambient temperatures of 68°F or less.
- 11) Humidity levels vary from 30 to 50% with levels and tolerances a function of process requirements, prevention of condensation on cold surfaces within the clean room, and static electricity control. Tolerances are varying from ± 0.5 to 5% relative humidity. Static electricity problems are significantly reduced where humidity's are above 50%; otherwise suitable antistatic provisions such as materials/flooring are provided.
- 12) The major internal load components are people, process equipment and fan energy. Because clean rooms are usually located within conditioned spaces, traditional infiltration, solar and heat conduction losses is minimal (less than 2 to 3% of the total load).
- 13) Fan energy is a very large heat source in Class 100 or better clean rooms, as re-circulated airflow rates of 90 CFM per square foot are typical. This is the equivalent of about 600 air changes per hour.
- 14) The latent load is primarily from makeup air. Low leaving air dry bulb temperatures of 35 to 45°F are typical to ensure relatively low humidity requirements of many processes.

- 15) Makeup air volumes are largely dictated by the amount of process exhaust and to maintain room pressurization and adequate ventilation to avoid excessive worker exposure to fumes and the like.
- 16) Makeup (outside) air handler is generally provided with pre-filter assembly and cooling coil to take care of sensible & humidity load of outside air. The dehumidification essentially takes place in the outside air handler.
- 17) The dehumidified air is forced into the re-circulation AHU's, which are provided with the cooling coil to primarily, cater for the internal sensible load.
- 18) Minimum 95% ASHRAE atmospheric dust test efficiency filters are used to avoid a high dust load on the HEPA filters.
- 19) A properly designed, installed, and maintained gaseous air cleaning system must be considered if the outdoor air is contaminated or the internal processes release gaseous contaminants that may be toxic, corrosive, irritants or have strong odors. The toxic removal is usually accomplished by chemical filtration consisting of absorbers such as carbon or potassium permanganate impregnated with alumina or zeolite technically known as 'Activated carbon or chemical filtration'.
- 20) In semiconductor clean rooms, the air stream sometimes contains acid, solvent, toxic fumes, and process heat, and therefore requires careful consideration of the material used in the ducts. The fiberglass reinforced plastic (FRP) ducts are sometimes used for corrosive fume exhaust systems.
- 21) The fans and conditioning of makeup air due to the clean room exhaust and pressurization are two key areas that offer huge potential of energy saving. These shall be designed and selected for optimal results.
- 22) The auxiliary equipment and facilities include changing rooms, air showers, hand-washing equipment, emergency eyewash and showers, Jet towel, pass box etc.

- 23) Static buildup occurs on wafers, storage boxes, work surfaces and equipment. These charges can reach as high as 50,000 volts and can attract aerosols out of the air. Attracted particles end up contaminating wafers and are difficult to remove. Static is controlled by prevention of charge buildup. Use of anti-static materials in garments, grounded mats and wrist straps are some of the ways used to control static.
-

Course Summary

A clean room is a space where the concentration of airborne particles is controlled to specified limits. The Federal standard 209E document establishes standard classes or air cleanliness for airborne particulate levels in clean rooms and clean zones. The standard prescribes methods for class verification and monitoring air cleanliness.

The complete HVAC installation is therefore of vital importance, in order to obtain a certain clean zone level. A room

The clean rooms are classified as class 1, 10, 100, 1000...accordance to the statistically allowable number of particles per cubic foot of air. For instance a class 100 clean room limits the concentration of airborne particles equal to or greater than 0.5 microns size to 100 particles in a cubic foot of air.

The purpose of the clean room air-conditioning system is to supply airflow in sufficient volume and cleanliness to support the cleanliness rating of the room. Air is introduced into the clean room in a manner to prevent stagnant areas where particles could accumulate. The air must also be conditioned to meet the clean-room temperature and humidity requirements. In addition, enough conditioned makeup air must be introduced to maintain the specified positive pressurization.

HEPA filters are a critical component in clean rooms. Clean room environments require highly filtered air that is frequently changed and delivered at precise conditions. Air-Handling units for

clean room application require specific custom units that accommodate laminar airflow, HEPA and ULPA filtration, and sealed-insulation construction.

The common approach in designing a clean room is to simply fix the filter velocity at 90 fpm and then specify different ceiling coverage percentages for different classification levels. This is a generic method based on experience on specific type of filtration and air handling equipment that may not be efficient and in many cases may result in over design. All aspects such as efficiency of filtration, type of air handling equipment, ceiling coverage, air changes, flow patterns, pressure difference must be properly evaluated to achieve effective and energy efficient end results.
